

Standard AC Motors

# Installation

Installation

# Installation

## Handling the Motor

### Handling

Always carry the motor by placing it in the original package. If the motor must be carried by itself during testing or for assembly into equipment, take note of the following points:

- Hold the motor so that the output shaft points upward.
- Hold the motor not by its output shaft or motor cable, but by the motor body.

### Storage

Temperature and humidity are important considerations since the storage condition has an influence on the life of motors. Storage in places where there are large temperature and humidity variations will reduce the stator's insulation performance. Moreover, leaving the motor for extended periods in places with high temperature and humidity is likely to lead to grease deterioration inside the ball bearing and corrosion. When storing for long periods, it is recommended to coat the output shaft with an anti-corrosion agent, seal the motor in a polyethylene bag and store in a place with normal temperature and humidity.

## Installation Conditions

Install the motor, gearhead and brake pack in a location that meets the following conditions. Use in a location that does not satisfy these conditions could damage the products.

- Indoors (This product is designed and manufactured to be installed within another device.)
- Ambient temperature:
  - Motors:  $-10\sim+50^{\circ}\text{C}$  ( $+14\sim+122^{\circ}\text{F}$ ) (non-freezing)
  - $[-10\sim+40^{\circ}\text{C}$  ( $+14\sim+104^{\circ}\text{F}$ ) for some motors]
  - SB50W:**  $[0\sim+40^{\circ}\text{C}$  ( $+32\sim+104^{\circ}\text{F}$ )]
- Ambient humidity: 85% or less (non-condensing)
- Not exposed to explosive, flammable or corrosive gases
- Not exposed to direct sunlight
- Not exposed to dust
- Not exposed to water, oil or other liquids
- A place where heat can escape easily
- Not exposed to continuous vibration or excessive impact
- Installation Category II, Pollution Degree 2, Class I Equipment
  - Only for the products that are certified by EN/IEC Standards and conform to EN/IEC Standards.
  - Installation Category III, Pollution Degree 3 for some products

## Motor and Gearhead Combinations



When connecting gearheads, be sure to match the pinion shafts and frame size. For details, refer to the page where each product is listed.

### Decimal Gearhead Combinations

The **GN**, **GE** and **GU** type gearheads are available with decimal gearheads (sold separately) with a gear ratio of 10:1 (Decimal gearhead of **0GN** type is not available). They should be used in applications in which large enough gear ratio cannot be attained with a single gearhead.

#### Note:

- Although the gear ratio of 10:1 of the decimal gearhead theoretically translates into 10 times increase of torque available on the output shaft, it is not possible to make full use of this torque. The permissible torque in actual use is limited by the physical construction of the gearhead and is expressed as its rated maximum torque.

## Gearhead and Motor Installation

### Method of Connecting Gearheads to Motors

As the figure below shows, a gearhead is combined with a motor using the pilots on each unit as guides. The gearhead should be moved gently from side to side without forcing the pinion shaft against the plate on the gearhead (metal plate) or against the gear itself.

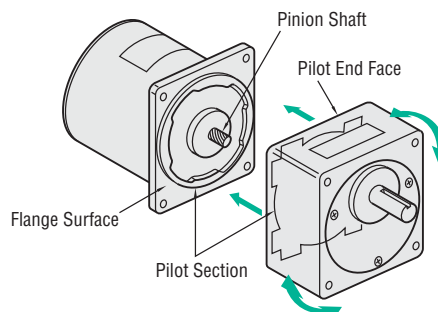

#### Note:

- Please note that an attempt to put motor and gearhead together by force, or an intrusion of foreign object such as metal fragment can result in damage to the pinion section of shaft or the gear, which may lead to unexpected accidents such as strange noise or shortened life.

### Motor Installation Direction

Motors can be mounted freely in any direction as shown below. Regardless of how the motor is mounted, take care not to apply an overhung load or thrust load on the shaft. Make sure the cable does not contact the mounting surface causing undesirable force on the cable.

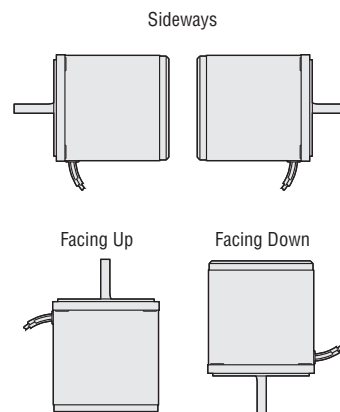

### ● Mounting Motor/Gearhead to Machinery

The motor flange is provided with a pilot section that serves as a guide not only when assembling the motor and gearhead but also when mounting the motor onto machinery.

The following figures show the mounting examples of the motor and gearhead onto machinery. Dedicated mounting bracket shown below is provided as an accessory.

● Mounting Brackets → Page A-288



Dedicated Mounting Bracket

When mounting motors that have a built-in cooling fan at the rear, leave a space 10 mm (0.39 in.) or more behind the fan cover or make ventilation holes so as not to block the cooling intake.

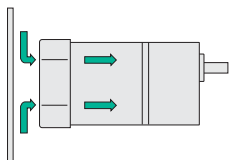

### ◇ For **GN** Gearheads, **5GE□SA**, **5GU□KA** and **GV** Gearheads

Use the "mounting screws" included with the gearhead and secure all the parts so that there is no gap between the motor flange face and the pilot end face of the gearhead.

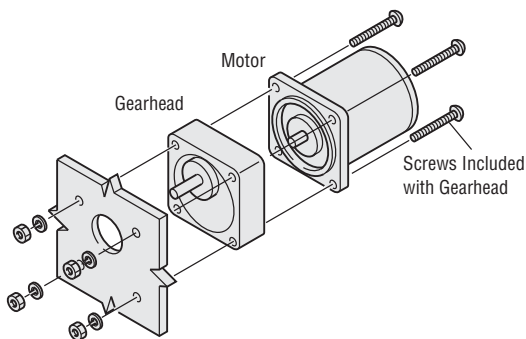

### ◇ For **V** Series Combination Type and **BH** Series

The **V** Series Combination Type and **BH** Series are combination type in which the motor and its dedicated gearhead are pre-assembled. Mount to machinery using the "mounting screws" included.

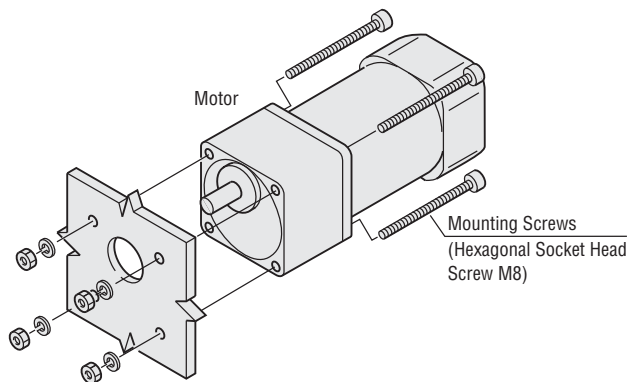

### ◇ For Right-Angle Gearheads

Attach the included gasket between the motor flange face and the pilot end face of the gearhead. Do not bent or scratch the gasket. Before mounting to machinery, assemble the motor and the gearhead using the screws included with the gearhead. (**BH** Series and **BHF** Series right-angle shaft combination type come with the motor and its dedicated gearhead pre-assembled.)

Mounting screws to machinery are not included. M6 screws (for **GN** gearhead) or M8 (for **GE** gearhead, **GU** gearhead, **BH** Series and **BHF** Series right-angle shaft combination type) must be purchased separately.

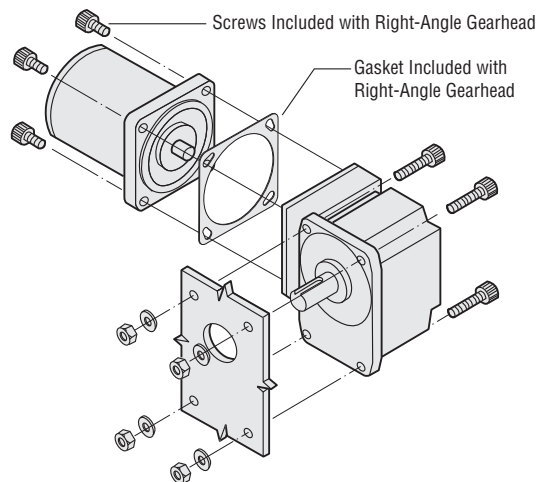

### ◇ For Mounting a Decimal Gearhead to **GN** Gearheads, **5GE□SA** or **5GU□KA**

Use the "mounting screws" included with the decimal gearhead and secure all the parts so that there are no gaps between the motor flange face and the pilot end face of the decimal gearhead, or between the decimal gearhead and the pilot end face of the gearhead.

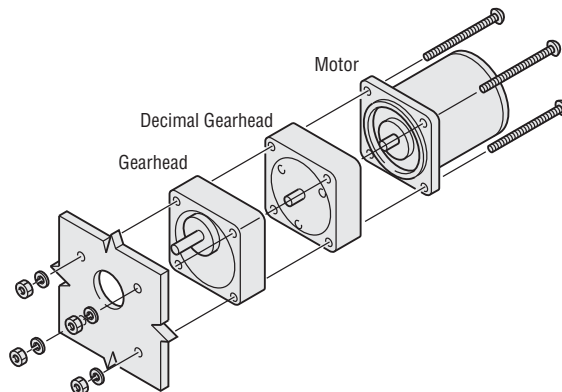

### ● Dimensions of Mounting Holes

The dimension of the four motor mounting holes is shown as pitch diameter in the dimensions of each product.

The distance between the mounting holes is shown in the table below.

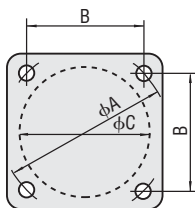

Unit = mm (in.)

Motor Frame Size	A	B	C*
□42 (□1.65)	48 (1.89)	33.94 (1.336)	37.6 (1.4803)
□60 (□2.36)	70 (2.76)	49.50 (1.949)	54 (2.1260)
□70 (□2.76)	82 (3.23)	57.98 (2.283)	64 (2.5197)
□80 (□3.15)	94 (3.70)	66.47 (2.617)	73 (2.8740)
□90 (□3.54)	104 (4.09)	73.54 (2.895)	83 (3.2677)
□104 (□4.09)	120 (4.72)	84.85 (3.341)	94 (3.7008)

\*C\* indicates the dimensions of flange pilot diameter of round shaft type.

### ● Mounting the Load

#### ◇ For Parallel Shaft Gearhead, Round Shaft Type

The output shafts of high-power gearheads are provided with a key slot to secure the load, while the output shafts of gearheads with comparatively low power have been given a shaft flat. Round shaft motors come in two types: those with or without a shaft flat on the motor output shaft.

#### ● Shaft Flat



#### ● When Using a Shaft Flat

With a shaft flat, use a locking screw to ensure that the load does not slip.

We recommend using double point screws or other screws with strong locking power.

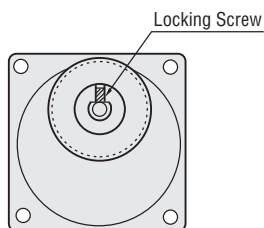

#### ● Key Slot



#### ● When Using a Key Slot

Secure the load shaft using the key included with the gearhead after machining the key slot on the equipment to be connected (sprocket etc.).

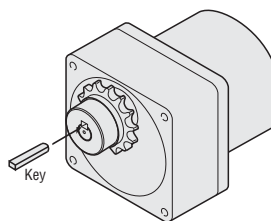

#### ● Output Shaft End Tapped Hole



#### ● When Using a Output Shaft End Tapped Hole

Use the output shaft end tapped hole [M5 10 mm (0.39 in.) deep min. or M6 12 mm (0.47 in.) deep min.] to help prevent the transmission part from becoming detached.

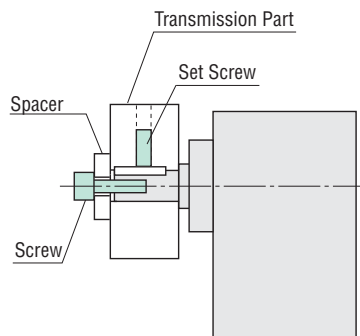

Example of Using the Output Shaft End Tapped Hole

On round shaft types, the output shaft is machined to the accuracy of h7 in dimension and 2/100 or less in eccentricity. Therefore, when connecting a load to the shaft of the device, take measurements using a dial gauge or similar instrument so that there is no eccentricity. When the shaft center of two shafts does not fit, use a flexible coupling (**MCL** coupling) etc. to avoid unnecessary strain on the shaft.

The same procedure should be applied when securing a load to gearheads.

● Flexible couplings → Page A-292

Unit = mm (in.)

Motor Frame Size	Shaft Diameter h7
□42 (□1.65)	$\phi 5 \begin{smallmatrix} 0 \\ -0.012 \end{smallmatrix}$ ( $\phi 0.1969 \begin{smallmatrix} 0 \\ -0.0005 \end{smallmatrix}$ )
□60 (□2.36)	$\phi 6 \begin{smallmatrix} 0 \\ -0.012 \end{smallmatrix}$ ( $\phi 0.2362 \begin{smallmatrix} 0 \\ -0.0005 \end{smallmatrix}$ )
□70 (□2.76)	$\phi 6 \begin{smallmatrix} 0 \\ -0.012 \end{smallmatrix}$ ( $\phi 0.2362 \begin{smallmatrix} 0 \\ -0.0005 \end{smallmatrix}$ )
□80 (□3.15)	$\phi 8 \begin{smallmatrix} 0 \\ -0.015 \end{smallmatrix}$ ( $\phi 0.3150 \begin{smallmatrix} 0 \\ -0.0006 \end{smallmatrix}$ )
	$\phi 10 \begin{smallmatrix} 0 \\ -0.015 \end{smallmatrix}$ ( $\phi 0.3937 \begin{smallmatrix} 0 \\ -0.0006 \end{smallmatrix}$ )
□90 (□3.54)	$\phi 10 \begin{smallmatrix} 0 \\ -0.015 \end{smallmatrix}$ ( $\phi 0.3937 \begin{smallmatrix} 0 \\ -0.0006 \end{smallmatrix}$ )
	$\phi 12 \begin{smallmatrix} 0 \\ -0.018 \end{smallmatrix}$ ( $\phi 0.4724 \begin{smallmatrix} 0 \\ -0.0007 \end{smallmatrix}$ )
□104 (□4.09)	$\phi 14 \begin{smallmatrix} 0 \\ -0.018 \end{smallmatrix}$ ( $\phi 0.5512 \begin{smallmatrix} 0 \\ -0.0007 \end{smallmatrix}$ )

◇ For Right-Angle Gearhead

These figures on the right show how to mount load depending on the shape of the shaft. The tolerance of the inner diameter for the hollow shaft is finished as shown in the table below, and "key slot" processing is given to mount the load shaft. Use the key provided with the product by fastening it to the shaft. Apply a coating of molybdenum disulfide or similar grease to the inner diameter of the load shaft to prevent sticking. Recommended load shaft diameter is shown below.

Unit = mm (in.)

Model	Inner Diameter of Hollow Shaft H8	Recommended Load Shaft Diameter h7
<b>4GN</b> □RH	$\phi 15^{+0.027}_0$ ( $\phi 0.5906^{+0.0011}_0$ )	$\phi 15^{0}_{-0.018}$ ( $\phi 0.5906^{0}_{-0.0007}$ )
<b>5GN</b> □RH	$\phi 15^{+0.027}_0$ ( $\phi 0.5906^{+0.0011}_0$ )	$\phi 15^{0}_{-0.018}$ ( $\phi 0.5906^{0}_{-0.0007}$ )
<b>5GE</b> □RH	$\phi 17^{+0.027}_0$ ( $\phi 0.6693^{+0.0011}_0$ )	$\phi 17^{0}_{-0.018}$ ( $\phi 0.6693^{0}_{-0.0007}$ )
<b>5GU</b> □RH	$\phi 17^{+0.027}_0$ ( $\phi 0.6693^{+0.0011}_0$ )	$\phi 17^{0}_{-0.018}$ ( $\phi 0.6693^{0}_{-0.0007}$ )
<b>BHI62</b> □-□RH	$\phi 25^{+0.033}_0$ ( $\phi 0.9843^{+0.0013}_0$ )	$\phi 25^{0}_{-0.021}$ ( $\phi 0.9843^{0}_{-0.0008}$ )
<b>BHI62</b> □T-□RH		
<b>BHI62</b> □MT-□RH		
<b>BHF62</b> □T-□RH		
<b>BHF62</b> □MT-□RH		

- Enter the gear ratio in the box (□) within the model name.  
Enter **A, F, C, E** or **S** (power supply voltage) in the box (□) within the model name.

● **4GN**□RH, **5GN**□RH, **5GE**□RH, **5GU**□RH  
Stepped Load Shaft

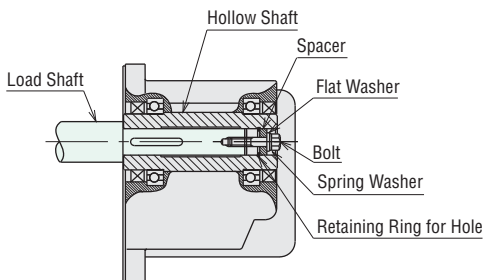

Straight Load Shaft

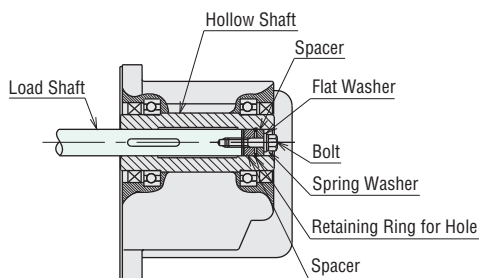

● **BH** Series, **BHF** Series Right-Angle, Hollow Shaft Type  
Stepped Load Shaft

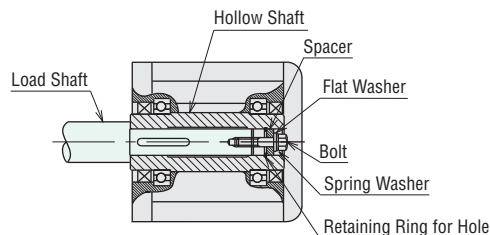

Straight Load Shaft

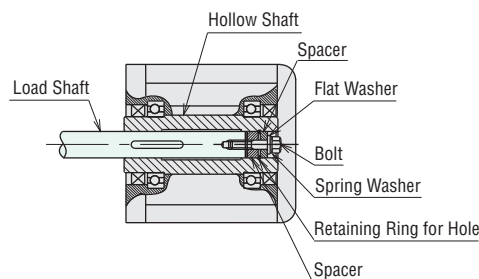

- After securing a load, attach the safety cover included.

Notes:

- Be careful not to apply a shock to the hollow shaft when mounting a load shaft. It may damage the bearing inside the gearhead.
- If the bolt extends out more than 4 mm (0.16 in.) from the end of the hollow shaft, a safety cover can not be installed.
- Bolts or other fasteners used to install the load shaft are not included. These parts must be purchased separately.

● Permissible Overhung Load and Permissible Thrust Load

When a chain, gear, belt, etc. is used as the transmission mechanism, the overhung load (a load applied in the right-angle direction of the output shaft) is always applied on the output shaft. Since the overhung load acts on the output shaft and its bearing directly, it has an influence on the life of gearhead. Be careful not to exceed the permissible value (specifications value).

If the overhung load greatly exceeds the permissible value, it will lead to the shortening of bearing life or damage to the bearing, as well as warping of the output shaft or fatigue loss after repeated load. In such situations, a support such as the one shown below must be designed to take up the overhung load.

Since connecting a transmission mechanism directly to the output shaft exerts an unbalanced load on the shaft, connect mechanisms as close to the gearhead as possible.

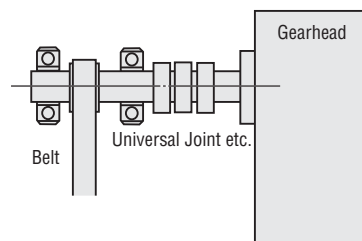

When using transmission mechanisms involving helical gears or worm gears, they are subject not only to overhung load but to thrust load (a load applied in the axial direction of the output shaft) as well. Ensure that the thrust load does not exceed the permissible value in the table.

Refer to page A-15 for the calculating formula of overhung load, and page A-16 for the permissible value (specifications value) of overhung load or thrust load.

## ● Dimensions for Mounting Screws

### ◇ GN Gearheads, GE Gearheads, GU Gearheads, Right-Angle Gearheads

- To assemble the motor and gearhead, use the screws included with the gearhead.
- Mounting screws to machinery (M8) are not included with right-angle gearhead. The screws must be purchased separately.

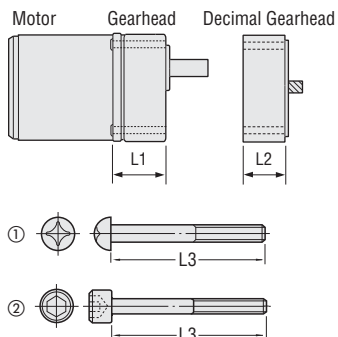

Model	Gearhead		Mounting Screw		
	L1 mm (in.)	L1+L2 mm (in.)	L3 mm (in.)	Size	Drawing
<b>0GN3KA~180KA</b>	31 (1.22)	—	40 (1.57)	No.4-40UNC	①
<b>2GN3SA~18SA</b>	37 (1.46)	—	50 (1.97)	No.8-32UNC	
<b>2GN25SA~180SA</b>	47 (1.85)	—	60 (2.36)	No.10-24UNC	
<b>3GN3SA~18SA</b>	39 (1.54)	—	50 (1.97)		
<b>3GN25SA~180SA</b>	49 (1.93)	—	65 (2.56)		
<b>4GN3SA~18SA</b>	39 (1.54)	—	50 (1.97)		
<b>4GN25SA~180SA</b>	49.5 (1.95)	—	65 (2.56)	1/4-20UNC	
<b>5GN3SA~18SA</b>	49.5 (1.95)	—	65 (2.56)		
<b>5GN25SA~180SA</b>	67.5 (2.66)	—	80 (3.15)	1/4-20UNC	
<b>5GE□SA, 5GU□KA</b>	72.5 (2.85)	—	95 (3.74)		
<b>2GN10XS (Decimal gearhead)</b>	—	73 (2.87)	85 (3.35)	M4 P0.7	②
<b>3GN10XS (Decimal gearhead)</b>	—	79 (3.11)	90 (3.54)	M5 P0.8	
<b>4GN10XS (Decimal gearhead)</b>	—	81.5 (3.21)	95 (3.74)		
<b>5GN10XS (Decimal gearhead)</b>	—	104.5 (4.11)	120 (4.72)		
<b>5GE10XS, 5GU10XKB (Decimal gearhead)</b>	—	112.5 (4.43)	140 (5.51)	M6 P1.0	
<b>4GN□RH, 4GN□RAA</b>	—	—	15 (0.59)	M5 P0.8	②
<b>5GN□RH, 5GN□RAA</b>	—	—	20 (0.79)	M6 P1.0	
<b>5GE□RH, 5GE□RAA, 5GU□RH, 5GU□RAA</b>	—	—	20 (0.79)		

- Mounting screws: 4 flat washers and hexagonal nuts are included.
- Hexagonal nuts are not included with the right-angle gearhead.
- The values of L1+L2 refer to sizes when a decimal gearhead is connected with a gearhead of 25:1 or greater in gear ratio.
- Enter the gear ratio in the box (□) within the model name.

### ◇ BH Series, BHF Series

The screw shown below is included with the motor.

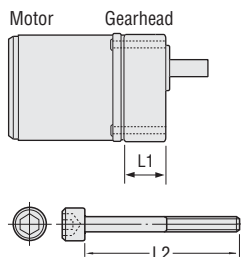

Model	L1 mm (in.)	L2 mm (in.)	Size
<b>BH162□-□, BH162□T-□, BHF62□T-□, BHF62□MT-□</b>	82.5 (3.25)	100 (3.94)	M8 P1.25

- Mounting screws: 4 flat washers, spring washers and hexagonal nuts are included.
- Screws are not included with BH Series and BHF Series right-angle shaft combination type.
- Enter **F**, **E** or **S** (power supply voltage) in the box (□) within the model name.  
Enter the gear ratio in the box (□) within the model name.

### ◇ V Series

The screw shown below is included with the gearhead.

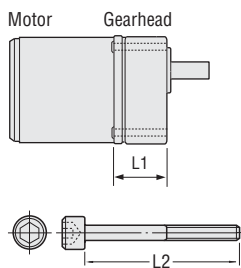

Model	L1 mm (in.)	L2 mm (in.)	Size
<b>GV2G5~25</b>	41 (1.61)	50 (1.97)	M4 P0.7
<b>GV2G30~120</b>	45 (1.77)	55 (2.17)	
<b>GV2G150~360</b>	50 (1.97)	60 (2.36)	
<b>GV3G5~25</b>	45 (1.77)	65 (2.56)	M6 P1.0
<b>GV3G30~120</b>	50 (1.97)	70 (2.76)	
<b>GV3G150~360</b>	55 (2.17)	75 (2.95)	
<b>GV4G5~25</b>	48 (1.89)	65 (2.56)	
<b>GV4G30~120</b>	53 (2.09)	70 (2.76)	
<b>GV4G150~360</b>	58 (2.28)	75 (2.95)	M8 P1.25
<b>GVH5G5~18</b>	52.5 (2.07)	75 (2.95)	
<b>GVH5G25~100</b>	65.5 (2.58)	90 (3.54)	
<b>GVH5G120~300</b>	71.5 (2.81)	95 (3.74)	
<b>GVR5G5~15</b>	52.5 (2.07)	75 (2.95)	
<b>GVR5G18~36</b>	65.5 (2.58)	90 (3.54)	
<b>GVR5G50~180</b>	77.5 (3.05)	100 (3.94)	

- Mounting screws: 4 flat washers, spring washers and hexagonal nuts are included.

◇ **GC Gearheads, GCH Gearheads**

The screw shown below is included with the gearhead.

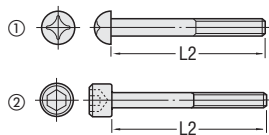
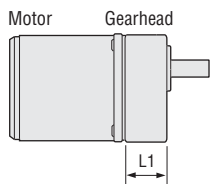

Gearhead		Mounting Screw		
Model	L1 mm (in.)	L2 mm (in.)	Size	Drawing
<b>5GC3.6KA~18KA</b>	42 (1.65)	65 (2.56)	M6 P1.0	①
<b>5GC25KA~180KA</b>	60 (2.36)	80 (3.15)		②
<b>5GCH□KA</b>	65 (2.56)	95 (3.74)		

- Mounting screws: 4 flat washers and hexagonal nuts are included.
- Since **GC** and **GCH** gearhead are attached from the gearhead side, L1 shows the length of the gearhead only.
- Enter the gear ratio in the box (□) within the model name.

◇ **FPW Series**

The screw shown below is included with the motor.

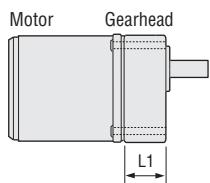

Geared Motor		Mounting Screw	
Model	L1 mm (in.)	L2 mm (in.)	Size
<b>FPW425</b> □ 2- □ □	59 (2.32)	80 (3.15)	M5 P0.8
<b>FPW540</b> □ 2- □ □	72.5 (2.85)	90 (3.54)	M6 P1.0
<b>FPW560</b> □ 2- □ □	74.5 (2.93)	90 (3.54)	
<b>FPW690</b> □ 2- □ □	82.5 (3.25)	100 (3.94)	M8 P1.25

- Mounting screws: 4 flat washers and hexagonal nuts are included.
- Stainless steel screws are included.
- Enter the gear ratio in the box (□) within the model name.  
Enter **A**, **C** or **S** (power supply voltage) in the box (□) within the model name.  
Enter **U** or **E** (capacitor model) in the box (■) within the model name.

## Linear Head Installation

### Installation Direction of Linear Head

There are no restrictions on the installation direction of linear head.

### Mounting Method

- Secure the linear head firmly on a metal plate.
- Make a mounting hole or tapped hole on the mounting plate.  
For **F** type (vertical stroke), make an additional hole for the rack.
- Using the 4 mounting holes on the mounting surface of linear head, secure the linear head with 4 screws so that there is no gap between the linear head and the metal plate. (Mounting screws are not included.)

### Installing with Mounting Flange

For **B** Type

For **F** Type

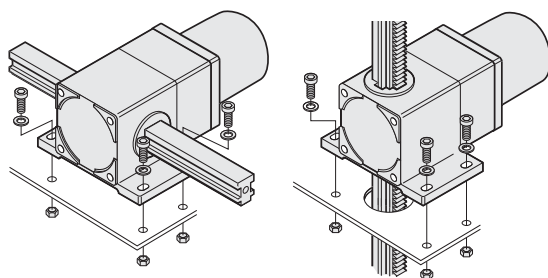

### Installing with Front Mounting Holes

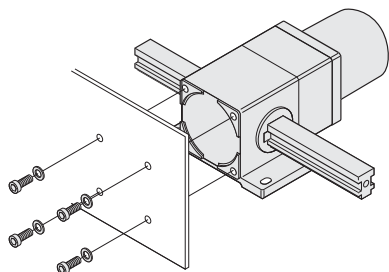

### Installation Conditions

Linear heads are designed and manufactured to be mounted in a machinery.

Make sure the installation location meets the following conditions as well-ventilated space with easy access for inspection.

- Inside an enclosure installed indoors (with ventilation holes provided)
- Ambient temperature:  $-10\sim+50^{\circ}\text{C}$  ( $+14\sim+122^{\circ}\text{F}$ ) (non-freezing)
- Ambient humidity: 85% or less (non-condensing)
- Not exposed to an explosive atmosphere, toxic gases (sulfurized gases etc.) or liquids
- Not exposed to direct sunlight
- Not exposed to significant amounts of dust or iron powder
- Not directly exposed to water or oil
- Not exposed to continuous vibration or excessive impact

### Precautions in Handling

#### ◇ Rack Lubrication

A lubricating agent is necessary to prevent friction when the rack passes through the rack grommet. The surface of the rack and any gears that mesh with the pinion should always be kept lubricated. Since the rack case is filled with a lubrication agent, there is no need to lubricate the rack case. However, ensure that the surface of the rack or gear teeth do not become dry, as operating in this condition will shorten the product's life. When a rack is used vertically, or under high ambient temperature, the separated grease may drip. If the drip is a problem, take measures such as putting a saucer under the rack.

### Precautions for Installation

#### ◇ Connecting Linear Heads to Motors

As the figure below shows, a linear head is combined with a motor using the pilots on each unit as guides. The linear head should be moved gently from side to side without forcing the pinion shaft against the gear of linear head. Please note that an attempting to put a motor and linear head together by force can result in damage to the tooth surface, causing strange noise.

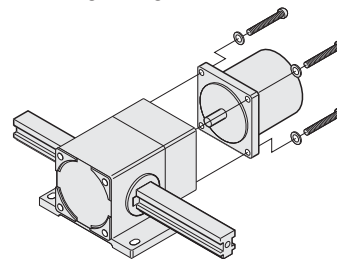

#### ◇ Mounting the Load to End of Rack

When mounting the load using the tapped hole on the end of the rack, hold the flat face of the rack rather than the toothed surface with a wrench while tightening the screw so that a rotational force is not applied to the rack. Note that the installation of the load with a rotational force applied to the rack can result in damage to the product.

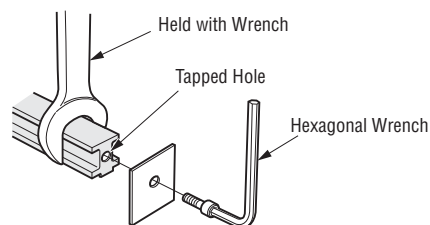

### Precautions for Operation

#### ◇ Do Not Hit a Hard Stop to Stop the Rack

Despite differences in control methods, rack and pinion systems are all moved by controlling motor.

Do not hit a hard stop to stop the operation at the end of the rack. Using like this, the motor will apply not only excessive torque but also an inertial shock to the rack-and-pinion section, as a result, the gear will be damaged.

#### ◇ Do Not Exceed the Maximum Transportable Mass

The maximum transportable mass of each product is determined. Generally, the lower the motor's basic speed, the greater the maximum transportable mass becomes. If a load greater than this value is applied, or rack movement is locked for a long time, it is likely to result in damage to the rack-and-pinion section.

### ◇ Use an Electromagnetic Brake Motor for Vertical Operation

Use an electromagnetic brake motor that can hold the load for vertical operation. The electromagnetic brakes that can be combined with linear heads, are power off activated type that are engaged in the event of a power failure and generate large holding force. The combination of a reversible motor has a certain amount of holding force, but the brake force is limited and unsuitable for load holding at vertical operation.

## ■ Capacitor Installation

### ● Mounting Method of Capacitor

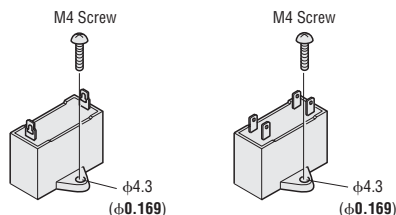

Attach a capacitor securely, using an M4 screw.

#### Note:

- The M4 screw is not included.

## ■ Control Circuit Installation

### ● Mounting Method of Control Circuit

The following figures show the mounting examples of control circuit such as a speed controller, speed control unit, inverter, brake pack, etc. inside a machinery. Mounting screws to machinery are not included. They must be purchased separately.

#### Note:

- When mounting the control circuit in an enclosed space such as a control box or somewhere close to a heat-radiating object, vent holes should be used to prevent the control circuit from overheating. If the ambient temperature listed in the installation conditions for the control circuit is exceeded, use forced air cooling with a fan.

### ◇ DIN Rail Mounting Using Flush Mounting Socket

1. Mount the flush mounting socket to the DIN rail. (The DIN lever should face down.)
2. Insert the controller terminals firmly into the flush mounting socket.
3. Engage the fastening hooks (two places) of the flush mounting socket on the controller to secure the assembly.

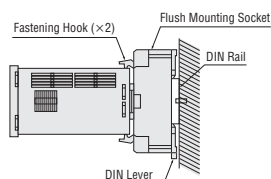

#### Note:

- Mount the brake pack only after connecting all required leads to the terminals of the flush mounting socket.

### ● Mounting Method of Two or More Control Circuits

When mounting two or more control circuits, separate them by a space of at least 20 mm (0.79 in.) and 50 mm (1.97 in.) in the horizontal and vertical directions, because the ambient temperature rises due to the temperature rise of the control circuit itself. Also, leave at least 25 mm (0.98 in.) of space between the control circuit and other devices or structures. Make sure not to cover the heat sink and heat radiation vents on the sides and bottom of the control circuits.

## ■ Connecting the Motor

### ● Lead Wire for Power Supply

For power supply, use a thicker lead wire than the motor lead wire.  
Frame size 42 mm (1.65 in.): AWG24, AWG22  
Frame size 60 mm (2.36 in.) or larger: AWG20

### ● How to Connect a Capacitor

When motors are running, a voltage of almost twice the motor power supply voltage is applied across the terminals of the capacitor. The terminal should be insulated for safety. Use the capacitor cap provided to insulate the terminals.

### ◇ 2-Terminal Capacitor

- Connecting method of capacitor and motor (CW rotation)  
Example: **4SK15GN-AUL**

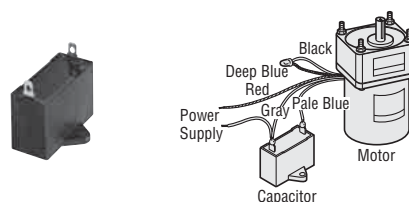

### ◇ 4-Terminal Capacitor

Terminals of the capacitor are connected inside as shown in the figure. For lead wire connection, use one lead wire per terminal.

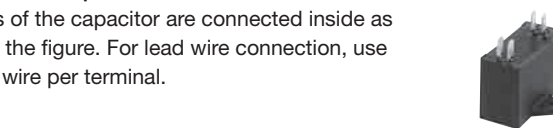

Inner Wiring Diagram for 4-Terminal Capacitor

- Connecting method of capacitor and motor (Induction motor/CW rotation)  
Example: **4IK25GN-AW2U**

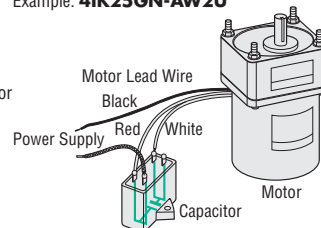

● Grounding the Motor

Ground the protective earth terminal ⊕ of the motor.

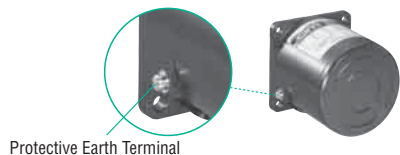

Applicable crimp terminal:  
 Round terminal with insulation  
 Terminal screw size: M4  
 Applicable lead wire: AWG18 min.

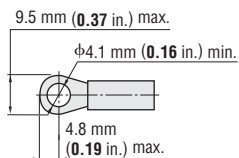

For motors without a protective earth terminal, any one of the four mounting bolts may be used to attach the ground wire to the motor case. If necessary, remove all paint that may impede conductivity around the bolt mounting hole.



◇ Terminal Box Type

Connect the ground wire to the protective earth terminal inside the terminal box.

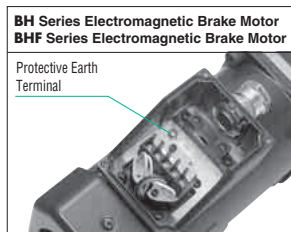
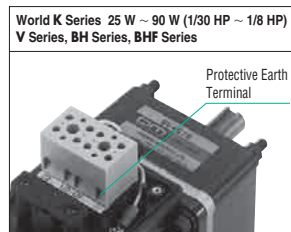

◇ Conduit Box Type

Conduit box mounted motors have a ground lead wire (green wire). Connect the ground wire to this green lead wire.

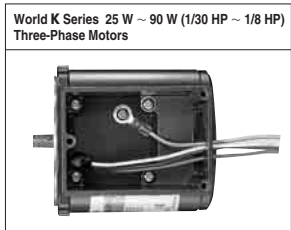
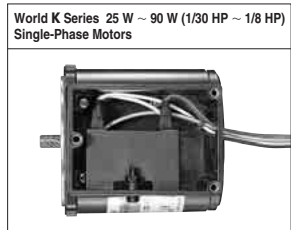

● Motor with Terminal Box

◇ Terminal Box: World K Series [25 W~90 W (1/30 HP~1/8 HP)], V Series, BH Series, BHF Series

Material of terminal box: Plastic  
 Applicable cable diameter:  $\phi 6 \sim \phi 12$  mm  
 ( $\phi 0.24 \sim \phi 0.47$  in.)  
 Applicable lead wire: AWG24~12  
 Strip length: 8 mm (0.315 in.)

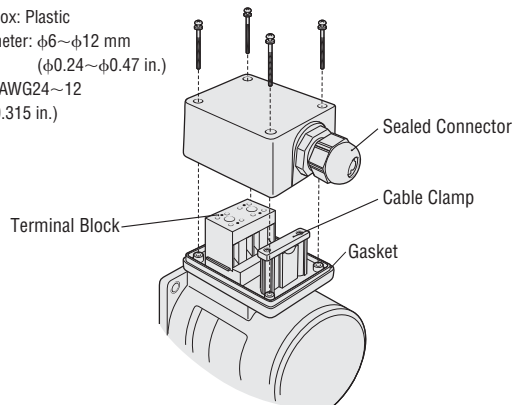

- When connecting cables to the terminal block, loosen the screw on the insertion port for the lead wire and insert the lead wire with a screw driver. Then tighten the screw securely.
- Cable entry is possible at one side of the terminal box.

◇ Conduit Box Type

Conduit box type is available for induction motors.

- Open the terminal box and connect wires.
- Use applicable cable ground and conduit for conduit opening.
- After connecting, close the terminal box with the terminal cover.

Single-Phase 25 W (1/30 HP), 40 W (1/19 HP) / Three-Phase 90 W (1/8 HP)

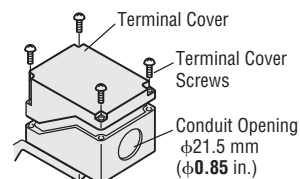
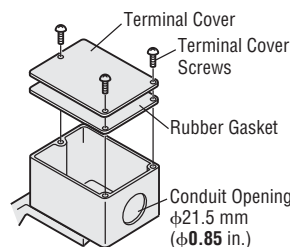

◇ Terminal Box: BH Series Electromagnetic Brake Motor BHF Series Electromagnetic Brake Motor

Material of terminal box: Die cast aluminum  
 Applicable cable diameter:  $\phi 8 \sim \phi 12$  mm ( $\phi 0.31 \sim \phi 0.47$  in.)  
 Applicable lead wire: AWG18 min.

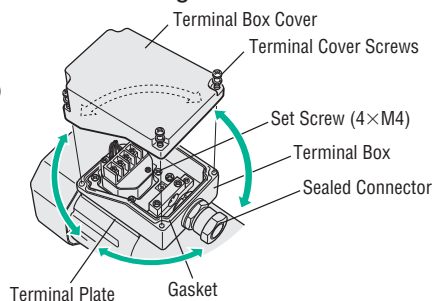

- Cable entry is possible at four sides of the terminal box.

● Applicable Crimp Terminals

Round Terminal with Insulation

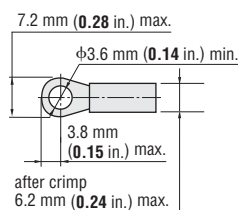

U-Shape Terminal with Insulation

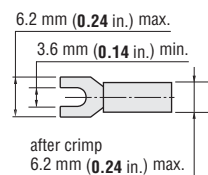

## Motor Operation

### Power Supply

Oriental Motor's standard AC motors are driven by AC power supply. Capacitors included with the motors must always be connected to single-phase motors.

### Rotation Direction

Clockwise (CW) direction of rotation, as referred to in the connection diagrams of this catalog, is defined as the direction of rotation when viewing from the shaft end of the motor.

When a motor is used with a gearhead connected, the direction of gear shaft rotation may be the same or the opposite as the motor shaft, depending on the gear ratio. To set the gear shaft rotation required, or to change the rotation direction of the motor, do as shown below.

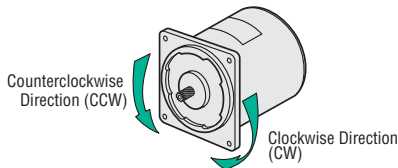

### Induction Motor

Change the direction of single-phase motor rotation only after bringing the motor to a stop.

If an attempt is made to change the direction of rotation while the motor is rotating, motor may ignore reversing command or change its direction of rotation after some delay.

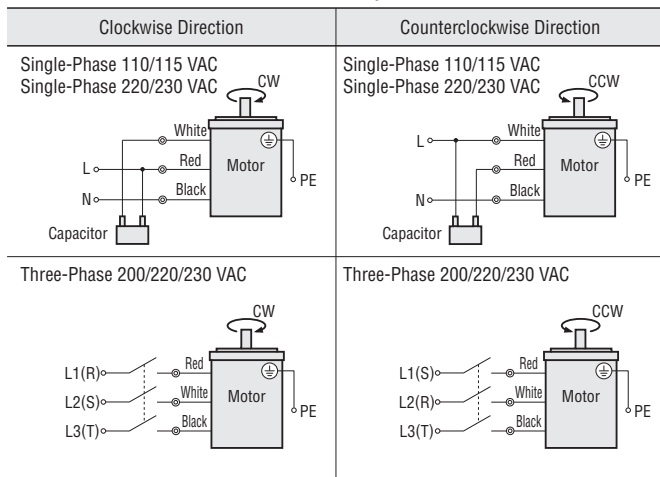

PE: Protective Earth

### Reversible Motor

Rotation direction can be switched while motor is running. To rotate the motor in a clockwise (CW) direction, turn the switch to CW; to rotate the motor in a counterclockwise (CCW) direction, turn the switch to CCW.

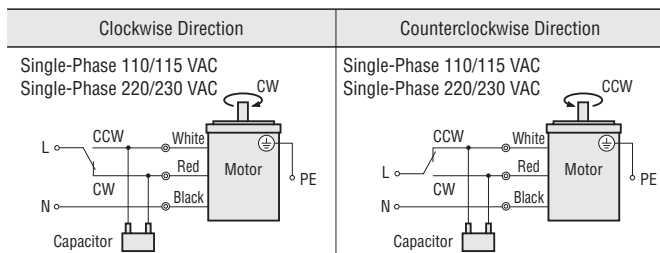

PE: Protective Earth

### Contact Capacity

Connect a CR circuit for surge suppression shown on the right to protect the contact.

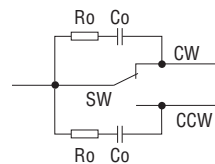

Code	Contact Capacity, Others	Note
SW	125 VAC 5 A min. or 250 VAC 5 A min. (Inductive load)	-
Ro, Co	Ro = 5~200 Ω Co = 0.1~0.2 μF	200 W (400 W) Accessories <b>EPCR1201-2</b> Page A-302

## Brake Pack

### Fuse Capacity

When a brake pack is used to stop the motor instantaneously, a large amount of braking current will flow into the motor for approximately 0.4 second. Therefore, when connecting a fuse to the power line, select one with an appropriate capacity by referring to the braking current (listed in "braking current," as provided with a brake pack) for the motor being used.

