

Standard AC Motors

Constant Speed Motors

Synchronous Motors

Introduction

Induction Motors

Reversible Motors

Electro-magnetic Brake Motors

V Series

Clutch & Brake Motors

Synchronous Motors

Synchronous Motors

Low-Speed Synchronous Motors

Watertight, Dust-Resistant Motors

Torque Motors

Right-Angle Gearheads

Linear Heads

Brake Pack

Accessories

Installation

RoHS RoHS-Compliant

Synchronous Motors

● Additional Information ●
 Technical reference → Page F-1
 Safety standards → Page G-2

Synchronous motors provide rotation at a fixed speed in synchronization with the power supply frequency. Suitable for applications where the motor is operated continuously in uni-direction and must be kept at a fixed speed regardless of load fluctuation.



● List of safety standard approved products (Model, Standards, File No., Certification Body)
 → Page G-11



(Gearhead sold separately)

Features

● Synchronous Rotation

Synchronous Motors provide rotation at a fixed speed in synchronization with the power supply frequency. Certain degree of changes of load and power supply voltage does not affect the motor speed. Synchronous speed is 1800 r/min at 60 Hz.

It is possible to decrease motor speed accurately according to the gear ratio by attaching a gearhead.

● **RoHS** RoHS-Compliant

Synchronous Motors conform to the RoHS Directive that prohibits the use of six chemical substances including lead and cadmium.

● Details of RoHS Directive → Page G-38

● Long Life, Low Noise **GN-S** Gearhead is Available.

The “long life, low noise **GN-S** gearhead” achieves a long rated life of 10000 hours, twice the level of a conventional gearhead, by adopting innovative technologies and structure. Also, the gearhead is designed for low noise.

● Details of long life, low noise **GN-S** gearhead → Page A-21



System Configuration

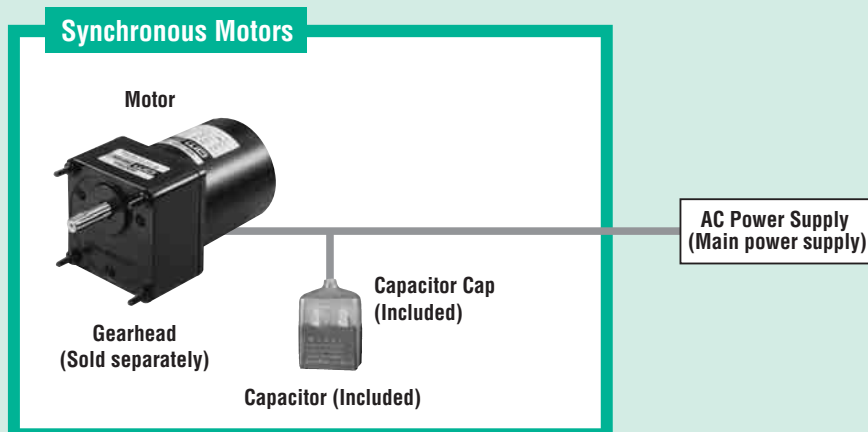

No.	Product Name	Overview	Page
①	Mounting Brackets	Dedicated mounting bracket for the motor and gearhead.	A-288
②	Flexible Couplings	Clamp type coupling that connects the motor or gearhead shaft to the driven shaft.	A-292

● Example of System Configuration



● Gearheads cannot be combined with round shaft type motors.

● The system configuration shown above is an example. Other combinations are available.

Product Number Code

Motor

5 S K 25 GN - A UL

① ② ③ ④ ⑤ ⑥ ⑦ ⑧

Gearhead

5 GN 50 SA

① ② ③ ④

Product Line

Motor (RoHS)

Output Power	Power Supply Voltage	Motor Model	
		Pinion Shaft Type	Round Shaft Type
4 W (1/190 HP)	Single-Phase 115 VAC	2SK4GN-AUL	2SK4A-AULA
10 W (1/75 HP)	Single-Phase 115 VAC	3SK10GN-AUL	3SK10A-AULA
15 W (1/50 HP)	Single-Phase 115 VAC	4SK15GN-AUL	4SK15A-AULA
25 W (1/30 HP)	Single-Phase 115 VAC	5SK25GN-AUL	5SK25A-AULA

The following items are included in each product.
Motor, Capacitor, Capacitor Cap, Operating Manual

①	Motor Frame Size	2: 60 mm (2.36 in.) 4: 80 mm (3.15 in.)	3: 70 mm (2.76 in.) 5: 90 mm (3.54 in.)
②	Motor Type	S: Synchronous Motor	
③	Series	K: K Series	
④	Output Power (W)	(Example) 25: 25 W (1/30 HP)	
⑤	Motor Shaft Type, Type of Pinion	A: Round Shaft GN: GN Type Pinion Shaft	
⑥	Power Supply Voltage	A: Single-Phase 115 VAC	
⑦	UL: UL Recognized and CSA, VDE Certified		
⑧	A: Inch-sized Output Shaft (Only round shaft type)		

①	Gearhead Frame Size	2: 60 mm (2.36 in.) 4: 80 mm (3.15 in.)	3: 70 mm (2.76 in.) 5: 90 mm (3.54 in.)
②	Type of Pinion	GN: GN Type Pinion	
③	Gear Ratio	(Example) 50: Gear Ratio of 50:1 10X denotes the decimal gearhead of gear ratio 10:1	
④	SA: Long Life, Low Noise GN-S Gearhead, RoHS-Compliant		

Note:

- The right-angle gearhead cannot be combined.

Parallel Shaft Gearhead (Sold separately)

Long Life, Low Noise **GN-S** Gearhead (RoHS)

Applicable Motor Output Power (Pinion Shaft Type)	Gearhead Model	Gear Ratio
4 W (1/190 HP)	2GN <input type="checkbox"/> SA	3, 3.6, 5, 6, 7.5, 9, 12.5, 15, 18, 25, 30, 36, 50, 60, 75, 90, 100, 120, 150, 180
	2GN10XS (Decimal gearhead)	
10 W (1/75 HP)	3GN <input type="checkbox"/> SA	3, 3.6, 5, 6, 7.5, 9, 12.5, 15, 18, 25, 30, 36, 50, 60, 75, 90, 100, 120, 150, 180
	3GN10XS (Decimal gearhead)	
15 W (1/50 HP)	4GN <input type="checkbox"/> SA	3, 3.6, 5, 6, 7.5, 9, 12.5, 15, 18, 25, 30, 36, 50, 60, 75, 90, 100, 120, 150, 180
	4GN10XS (Decimal gearhead)	
25 W (1/30 HP)	5GN <input type="checkbox"/> SA	3, 3.6, 5, 6, 7.5, 9, 12.5, 15, 18, 25, 30, 36, 50, 60, 75, 90, 100, 120, 150, 180
	5GN10XS (Decimal gearhead)	

- Enter the gear ratio in the box () within the model name.

The following items are included in each product.
Gearhead, Mounting Screws, Operating Manual

- Following gearheads are also available. For details, please refer to website (<http://www.orientalmotor.com/>) or contact the nearest Oriental Motor sales office.

Gearhead Type	Gearhead Model	Gear Ratio
Parallel Shaft	2GN <input type="checkbox"/> KA	3~180
	2GN10XK (Decimal gearhead)	
	3GN <input type="checkbox"/> KA	3~180
	3GN10XK (Decimal gearhead)	
	4GN <input type="checkbox"/> KA	3~180
	4GN10XK (Decimal gearhead)	
	5GN <input type="checkbox"/> KA	3~180
	5GN10XK (Decimal gearhead)	

- Enter the gear ratio in the box () within the model name.

Specifications – Continuous Rating RoHS



Model		Output Power		Voltage VAC	Frequency Hz	Current A	Starting Torque		Rated Torque		Rated Speed r/min	Capacitor μ F
Pinion Shaft Type	Round Shaft Type	W	HP				mN·m	oz-in	mN·m	oz-in		
ZP 2SK4GN-AUL	2SK4A-AULA	4	1/190	Single-Phase 115	60	0.24	22	3.1	22	3.1	1800	1.0
TP 3SK10GN-AUL	3SK10A-AULA	10	1/75	Single-Phase 115	60	0.35	50	7.1	55	7.8	1800	1.5
TP 4SK15GN-AUL	4SK15A-AULA	15	1/50	Single-Phase 115	60	0.53	55	7.8	81	11.5	1800	1.5
TP 5SK25GN-AUL	5SK25A-AULA	25	1/30	Single-Phase 115	60	0.75	85	12.0	135	19.1	1800	3.0

ZP: Impedance protected

TP: Contains a built-in thermal protector (automatic return type). If a motor overheats for any reason, the thermal protector is activated and the motor is stopped. When the motor temperature drops, the thermal protector closes and the motor restarts. Be sure to turn the motor power off before inspecting.

General Specifications

Item	Specifications
Insulation Resistance	100 M Ω or more when 500 VDC megger is applied between the windings and the case after rated operation under normal ambient temperature and humidity.
Dielectric Strength	Sufficient to withstand 1.5 kVAC at 60 Hz applied between the windings and the case for 1 minute after rated operation under normal ambient temperature and humidity.
Temperature Rise	Temperature rise of windings is 75°C (135°F) or less measured by the resistance change method after rated operation under normal ambient temperature and humidity.
Insulation Class	UL, CSA: Class A [105°C (221°F)] EN: Class E [120°C (248°F)]
Overheat Protection	4 W (1/190 HP) type has impedance protection. All others have built-in thermal protector (automatic return type) Open: 120 \pm 5°C (248 \pm 9°F), Close: 77 \pm 15°C (170.6 \pm 27°F)
Ambient Temperature	-10 \sim +40°C (+14 \sim +104°F) (non-freezing)
Ambient Humidity	85% or less (non-condensing)
Degree of Protection	IP20

Gearmotor – Torque Table

- Gearheads and decimal gearheads are sold separately.
- Enter the gear ratio in the box () within the model name.
- A colored background () indicates gear shaft rotation in the same direction as the motor shaft, while the others rotate in the opposite direction.
- The speed is calculated by dividing the motor's synchronous speed (60 Hz: 1800 r/min) by the gear ratio.
- To reduce the speed beyond the gear ratio in the table, attach a decimal gearhead of gear ratio 10:1 between the gearhead and the motor. In that case, the permissible torques are as follows.

2GNSA: 3 N·m (26 lb-in)

3GNSA: 5 N·m (44 lb-in)

4GNSA: 8 N·m (70 lb-in) [6 N·m (53 lb-in) when a gearhead of 25:1~36:1 is attached]

5GNSA: 10 N·m (88 lb-in)

Unit = Upper values: N·m/Lower values: lb-in

Model Motor/Gearhead	Speed r/min Gear Ratio	600	500	360	300	240	200	144	120	100	72	60	50	36	30	24	20	18	15	12	10
		3	3.6	5	6	7.5	9	12.5	15	18	25	30	36	50	60	75	90	100	120	150	180
2SK4GN-AUL / 2GN <input type="text"/> SA	0.053	0.064	0.089	0.11	0.13	0.16	0.22	0.27	0.32	0.40	0.48	0.58	0.73	0.87	1.1	1.3	1.5	1.7	2.2	2.6	
	0.46	0.56	0.78	0.97	1.15	1.41	1.94	2.3	2.8	3.5	4.2	5.1	6.4	7.6	9.7	11.5	13.2	15.0	19.4	23	
3SK10GN-AUL / 3GN <input type="text"/> SA	0.13	0.16	0.22	0.27	0.33	0.40	0.56	0.67	0.80	1.0	1.2	1.4	1.8	2.2	2.7	3.3	3.6	4.4	5	5	
	1.15	1.41	1.94	2.3	2.9	3.5	4.9	5.9	7.0	8.8	10.6	12.3	15.9	19.4	23	29	31	38	44	44	
4SK15GN-AUL / 4GN <input type="text"/> SA	0.20	0.24	0.33	0.39	0.49	0.59	0.82	0.98	1.2	1.5	1.8	2.1	2.7	3.2	4.0	4.8	5.3	6.4	8	8	
	1.77	2.1	2.9	3.4	4.3	5.2	7.2	8.6	10.6	13.2	15.9	18.5	23	28	35	42	46	56	70	70	
5SK25GN-AUL / 5GN <input type="text"/> SA	0.33	0.39	0.55	0.66	0.82	0.98	1.4	1.6	2.0	2.5	3.0	3.5	4.5	5.3	6.7	8.0	8.9	10	10	10	
	2.9	3.4	4.8	5.8	7.2	8.6	12.3	14.1	17.7	22	26	30	39	46	59	70	78	88	88	88	

Permissible Overhung Load and Permissible Thrust Load

Motor (Round Shaft Type) → Page A-16

Gearhead → Page A-16

Permissible Load Inertia J of Gearhead

→ Page A-17

◆ Shaft Section of Round Shaft Type

The motor's dimensions (excluding the shaft section) are the same as those of the pinion shaft types.

3SK10A-AULA

Mass: 1.1 kg (2.4 lb.)

DXF A326U

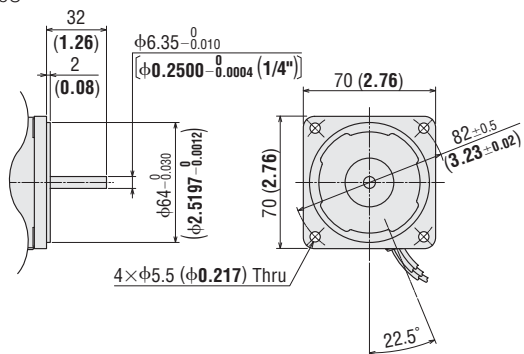

◆ Decimal Gearhead

Can be connected to **3SK10GN-AUL**.

3GN10XS

Mass: 0.3 kg (0.66 lb.)

DXF A009

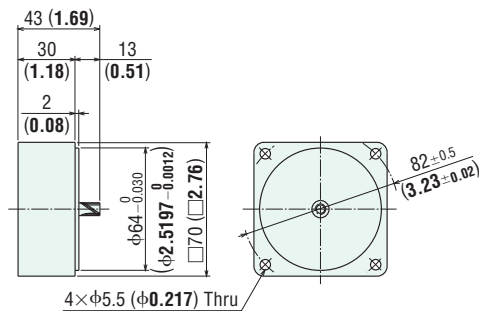

● 15 W (1/50 HP)

◆ Motor/Gearhead

Mass: Motor 1.5 kg (3.3 lb.)

Gearhead 0.65 kg (1.43 lb.)

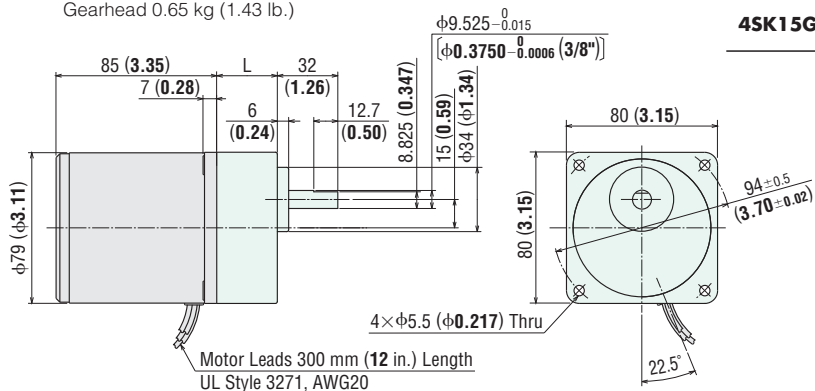

Motor Model	Gearhead Model	Gear Ratio	L	DXF
4SK15GN-AUL	4GN□SA	3~18	32 (1.26)	A910AU
		25~180	42.5 (1.67)	A910BU

◆ Shaft Section of Round Shaft Type

The motor's dimensions (excluding the shaft section) are the same as those of the pinion shaft types.

4SK15A-AULA

Mass: 1.5 kg (3.3 lb.)

DXF A327U

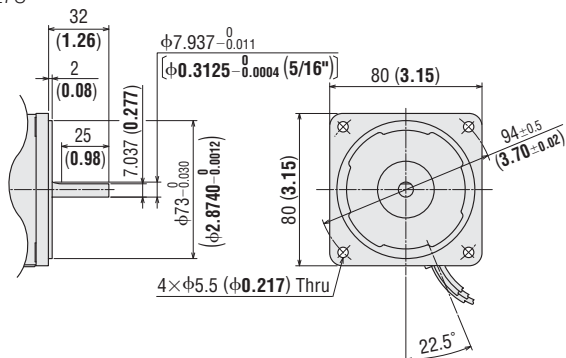

◆ Decimal Gearhead

Can be connected to **4SK15GN-AUL**.

4GN10XS

Mass: 0.4 kg (0.88 lb.)

DXF A013

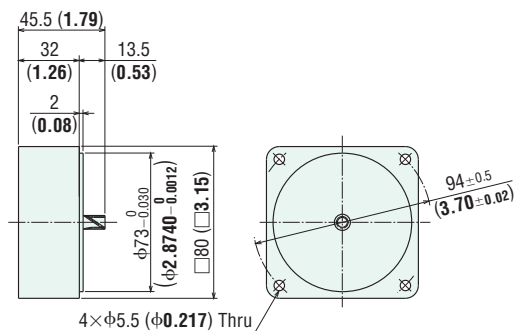

● Enter the gear ratio in the box (□) within the model name.

● 25 W (1/30 HP)

◇ Motor/Gearhead

Mass: Motor 2.5 kg (5.5 lb.)
Gearhead 1.5 kg (3.3 lb.)

Motor Model	Gearhead Model	Gear Ratio	L	DXF
5SK25GN-AUL	5GN□SA	3~18	42 (1.65)	A911AU
		25~180	60 (2.36)	A911BU

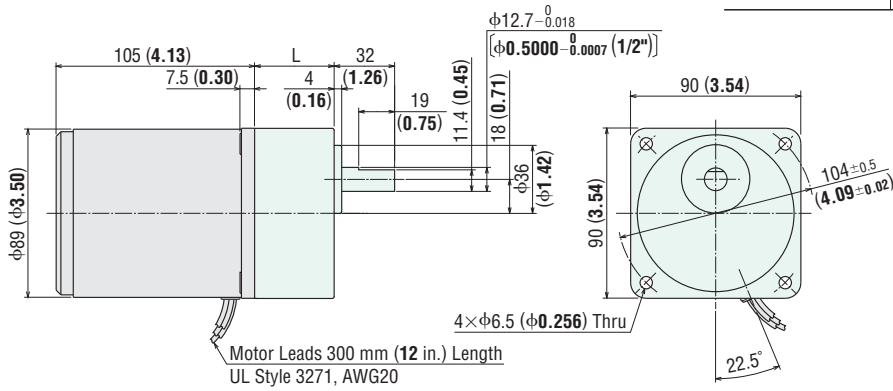

◇ Shaft Section of Round Shaft Type

The motor's dimensions (excluding the shaft section) are the same as those of the pinion shaft types.

5SK25A-AULA

Mass: 2.5 kg (5.5 lb.)

DXF A329U

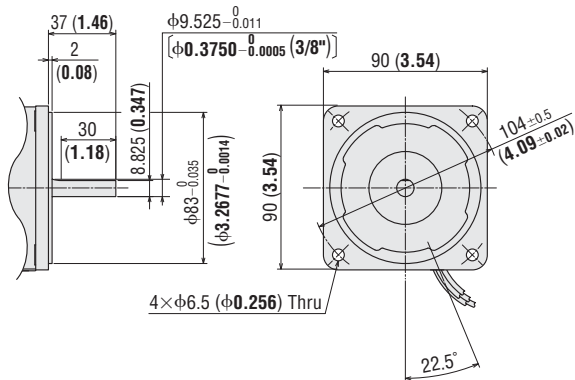

◇ Decimal Gearhead

Can be connected to **5SK25GN-AUL**.

5GN10XS

Mass: 0.6 kg (1.32 lb.)

DXF A022

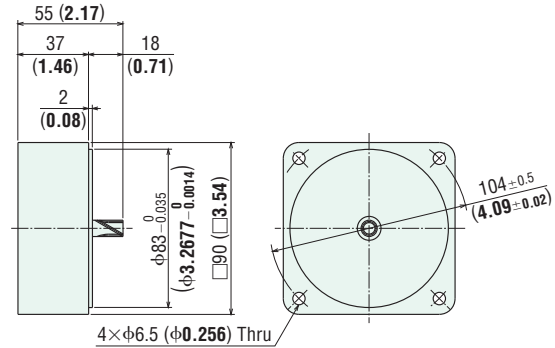

● Enter the gear ratio in the box (□) within the model name.

◇ Capacitor (Included)

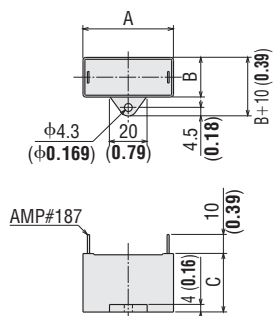

◇ Capacitor Dimensions Unit = mm (in.)

Model		Capacitor Model	A	B	C	Mass g (oz.)	Capacitor Cap
Pinion Shaft Type	Round Shaft Type						
2SK4GN-AUL	2SK4A-AULA	CH10BUL	31 (1.22)	17 (0.67)	27 (1.06)	23 (0.81)	Included
3SK10GN-AUL	3SK10A-AULA	CH15BUL	37 (1.46)	18 (0.71)	27 (1.06)	27 (0.95)	
4SK15GN-AUL	4SK15A-AULA	CH15BUL	37 (1.46)	18 (0.71)	27 (1.06)	27 (0.95)	
5SK25GN-AUL	5SK25A-AULA	CH30BUL	48 (1.89)	21 (0.83)	31 (1.22)	39 (1.38)	

■ Connection Diagrams

- The direction of motor rotation is as viewed from the shaft end of the motor. CW represents the clockwise direction, while CCW represents the counterclockwise direction.
- Connection diagrams are also valid for the equivalent round shaft type.

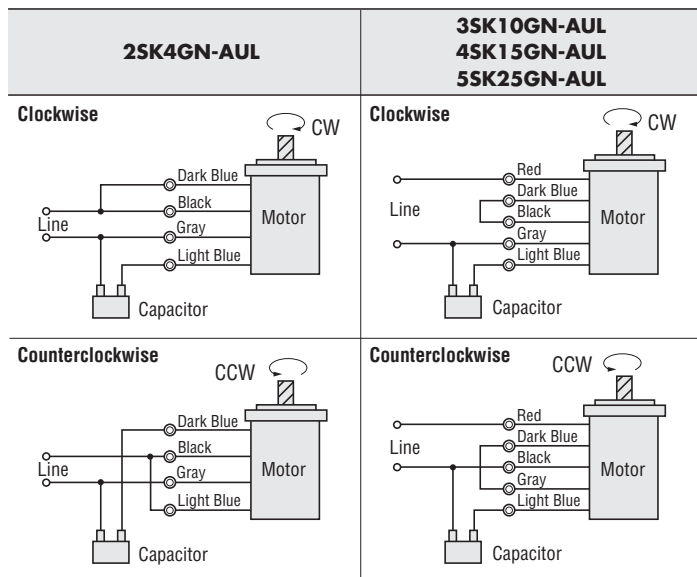

Note:

- Change the direction of motor rotation only after bringing the motor to a stop. If an attempt is made to change the direction of rotation while the motor is rotating, motor may ignore reversing command or change its direction of rotation after some delay.

- How to connect a capacitor → Page A-313

