

Selection Calculations

After you have determined which series to use, select the appropriate model. Select a linear slide/cylinder of the size that best suits your application.

Select the appropriate model by following the steps below.

(1) Select a Linear Slide/Cylinder Satisfying the Required Transportable Mass

By referring to the product specifications, select a linear slide/cylinder satisfying the required transportable mass.

Condition: Drive a load of 14 kg over a horizontal distance of 200 mm within 5 seconds.

EZC4: Specifications of Frame Size 42 mm × 42 mm, 24 VDC Cylinder

Specifications of Cylinder (RoHS)		CE					
Drive Method	Ball Screw	Repetitive Positioning Accuracy [mm] ±0.02		Resolution [mm]	0.01		
Model	Lead [mm]	Transportable Mass [kg] ^{*1}		Thrust [N]	Push Force [N] ^{*2}	Electromagnetic Brake Holding Force [N]	Maximum Speed [mm/s]
		Horizontal	Vertical				
EZC4D □-K	12	~15	—	~70	100	—	600
EZC4D □M-K		~6.5	—			70	
EZC4E □-K	6	~30	—	~140	200	—	300
EZC4E □M-K		~14	—			140	

● Enter the stroke length in the box (□) within the model name.

Based on the "condition" and "specifications of cylinder," select the cylinder model **EZC4D020-K**.

(2) Check the Positioning Time

From the graph "Positioning Distance – Positioning Time" below, check if the selected cylinder satisfies the desired positioning time.

From the graph, find the "positioning time of 4.0 s" for the "positioning distance of 200 mm."

Notes:

- The calculated positioning time does not include the settling time.
Use a settling time of 0.15 s as a reference.
- The running duty, which represents the relationship of running time and stopping time, should be kept to 50% or less (reference).
Running duty [%] = running time [s] × 100 / (running time [s] + stopping time [s])

Check the Positioning Time

● EZC4E (Lead: 6 mm)

◇ Vertical Installation

● Positioning Distance – Positioning Time

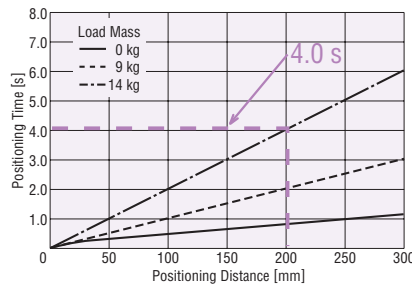

(3) Check the Operating Speed and Acceleration of the Linear Slide/Cylinder

The time calculated from "Check the Positioning Time" assumes the operating speed and acceleration that achieve the shortest positioning time. Check the specific operating speed and acceleration at which to drive the linear slide/cylinder based on the time calculated in step (2).

● SPV Series Linear Slides

◇ Operating Speed of the Linear Slide

Refer to the "maximum speed specification in Specification of Linear Slide."

◇ Acceleration of the Linear Slide

Check using the "Load Mass – Acceleration" graph.

● **EZCII/EZA/PWAI Series Cylinders**

◇ **Operating Speed and Acceleration of the Cylinder**

Check the operating speed and acceleration by referring to "Positioning Distance — Operating Speed" and "Positioning Distance — Acceleration."

Example) For a positioning distance of 200 mm on the graph, the operating speed is 50 mm/s, and the acceleration is 2.0 m/s².

EZC4E040-K "•Positioning Distance — Operating Speed"

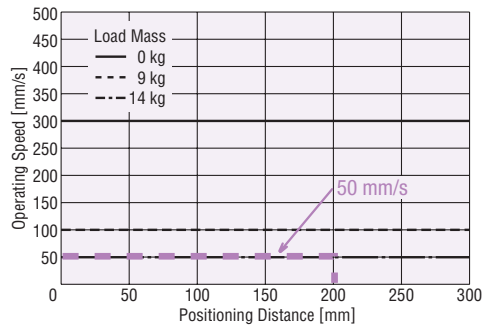

EZC4E040-K "•Positioning Distance — Acceleration"

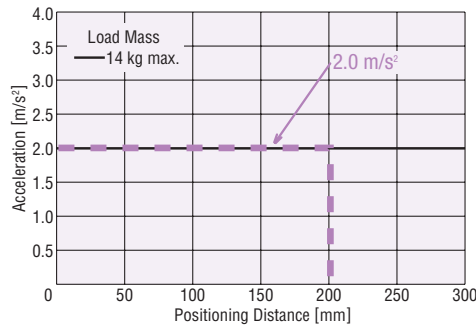

(4) Check the Load Moment

For the **SPV** Series linear slide and **EZA** Series cylinders, calculation of the load moment that will generate under the applicable condition is necessary. For the **EZA** Series, "maximum load moment in Specification of Cylinder" indicates the load moment of the built-in guide. Moment of the rod must be considered. Maximum load moment is the total value of rod moment and load moment. Calculate the load moment referring to the table below. Confirm that the calculated result is smaller than the "Maximum Load Moment" specified in product specifications. If the maximum load moment is exceeded, select another model.

The maximum load moment has been calculated by considering the estimated traveling life of each model. If a given model is operated at load moment exceeding the designed limit, the life of the linear slide/cylinder will decrease. The life is also affected by the operating environment and conditions.

● **SPV Series**

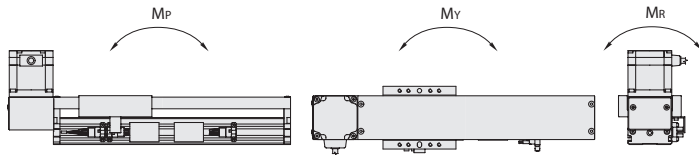

● **EZA Series**

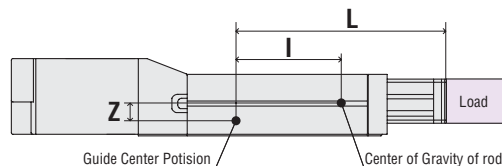
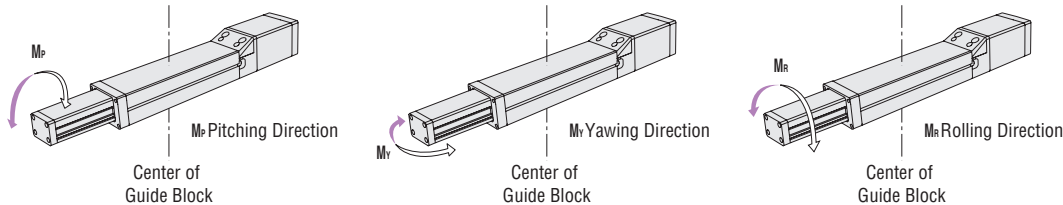

EZA4

Stroke	50	100	150	200	250	300
Mass of Rod (kg)	0.2	0.28	0.36	0.44	0.52	0.6
L Rod Overhung Length from Center of Guide Block (mm)	125	175	225	275	325	375
I Length from Center of Guide Block to Center of Gravity of Rod (mm)	43	68.5	94.5	120	146	171
Z Height from Center of Guide Block to Center of Gravity of Rod (mm)	21.5					

EZA6

Stroke	50	100	150	200	250	300
Mass of Rod (kg)	0.33	0.44	0.548	0.653	0.758	0.863
L Rod Overhung Length from Center of Guide Block (mm)	139	189	239	289	339	389
I Length from Center of Guide Block to Center of Gravity of Rod (mm)	44	70.5	96.5	122	147	173
Z Height from Center of Guide Block to Center of Gravity of Rod (mm)	28					

How to Calculate the Speed for Sensorless Return to Home Operation

The **EZA** Series can perform high-speed, sensorless return to home operation. The maximum return to home speed is 100 mm/s when the lead is 12 mm, and the maximum speed becomes 50 mm/s when the lead is 6 mm. Select the applicable calculation formula by referring to the cylinder installation conditions and calculate the maximum settable speed for return to home operation from the specific overhung length and load mass.

Note that the load will receive an impact if the sensorless return to home operation is performed at high speed.

* If there is an overhung load on both the Z-axis and Y-axis, compare V_z and V_y . The smaller of the two provides the maximum settable speed for return to home operation.

● Cylinder Installation Conditions (Horizontal, wall-mounted or ceiling-mounted)

◇ Overhung in Z-Axis Direction

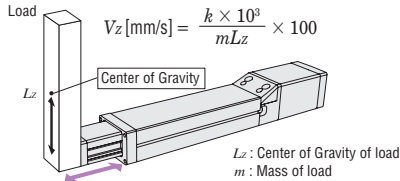

Cylinder Size	Strength Coefficient k	
	Lead 12 mm	Lead 6 mm
EZA4	38.0	60.8
EZA6	10.1	9.9

◇ Overhung in Y-Axis Direction

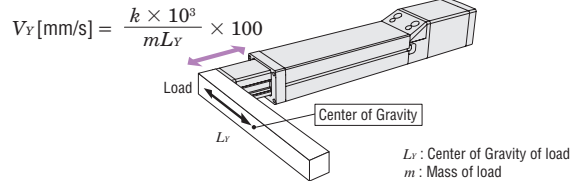

Cylinder Size	Strength Coefficient k	
	Lead 12 mm	Lead 6 mm
EZA4	21.1	33.8
EZA6	2.9	3.8

● Cylinder Installation Conditions (Vertical: Upward)

◇ Overhung in Z-Axis Direction

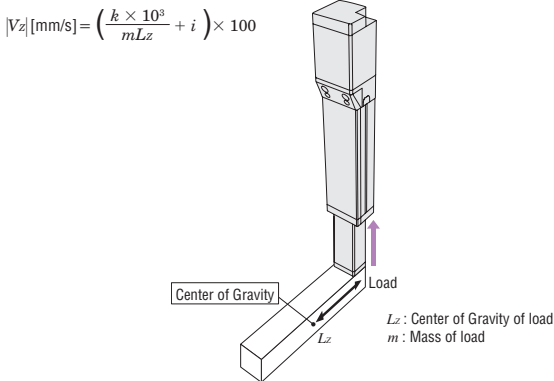

Cylinder Size	Strength Coefficient k		Upward Coefficient i	
	Lead 12 mm	Lead 6 mm	Lead 12 mm	Lead 6 mm
EZA4	58.9	60.8	3.2	3.3
EZA6	12.2	17.7	0.3	0.5

◇ Overhung in Y-Axis Direction

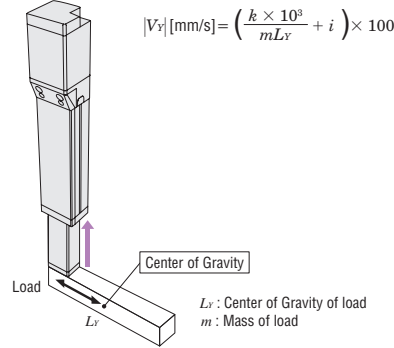

Cylinder Size	Strength Coefficient k		Upward Coefficient i	
	Lead 12 mm	Lead 6 mm	Lead 12 mm	Lead 6 mm
EZA4	32.7	33.8	3.2	3.3
EZA6	4.7	6.9	0.5	0.5

● Cylinder Installation Conditions (Vertical: Downward)

◇ Overhung in Z-Axis Direction

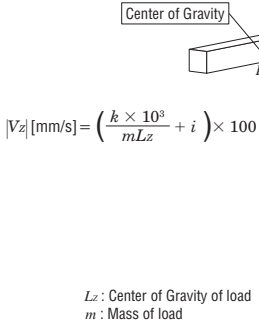

Cylinder Size	Strength Coefficient k		Downward Coefficient i	
	Lead 12 mm	Lead 6 mm	Lead 12 mm	Lead 6 mm
EZA4	35.1	41.5	-1.9	-2.2
EZA6	5.1	3.9	-0.1	-0.2

◇ Overhung in Y-Axis Direction

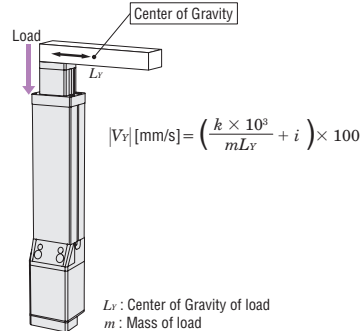

Cylinder Size	Strength Coefficient k		Downward Coefficient i	
	Lead 12 mm	Lead 6 mm	Lead 12 mm	Lead 6 mm
EZA4	19.5	23.0	-1.9	-2.2
EZA6	2.0	1.5	-0.1	-0.2

EZA Series Positioning Distance – Operating Speed, Positioning Distance – Acceleration

● EZA4D (Lead 12 mm, 24 VDC)

◇ Horizontal Installation

● Positioning Distance – Operating Speed

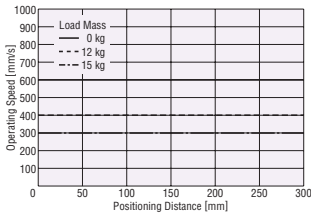

● Positioning Distance – Acceleration

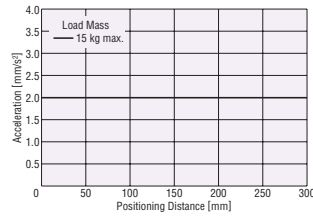

◇ Vertical Installation

● Positioning Distance – Operating Speed

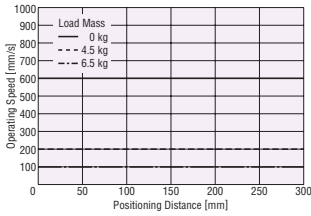

● Positioning Distance – Acceleration

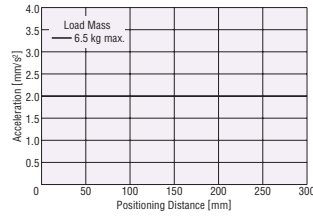

● EZA4E (Lead 6 mm, 24 VDC)

◇ Horizontal Installation

● Positioning Distance – Operating Speed

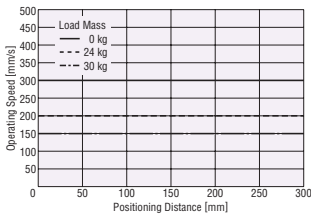

● Positioning Distance – Acceleration

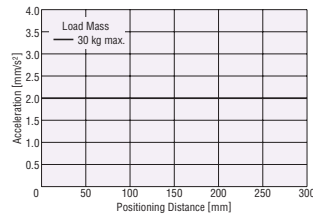

◇ Vertical Installation

● Positioning Distance – Operating Speed

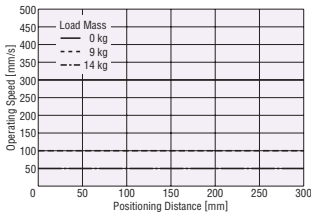

● Positioning Distance – Acceleration

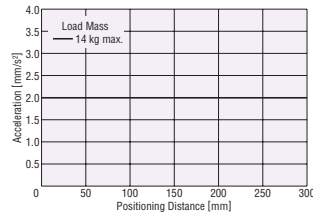

● EZA4D (Lead 12 mm, Single-Phase 100 VAC/Single-Phase 200-230 VAC)

◇ Horizontal Installation

● Positioning Distance – Operating Speed

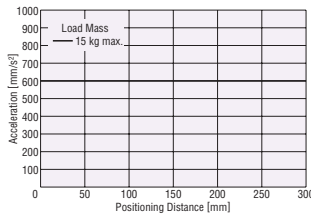

● Positioning Distance – Acceleration

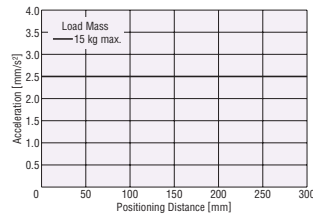

◇ Vertical Installation

● Positioning Distance – Operating Speed

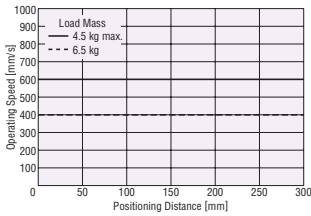

● Positioning Distance – Acceleration

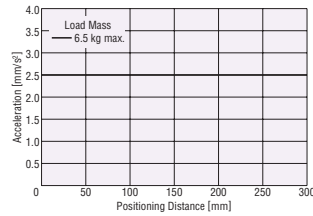

● **EZA4E** (Lead 6 mm, Single-Phase 100 VAC/Single-Phase 200-230 VAC)

◇ Horizontal Installation

● Positioning Distance — Operating Speed

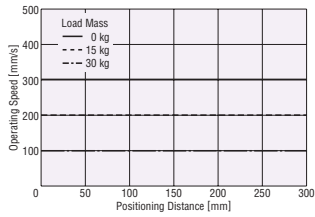

Positioning Distance — Acceleration

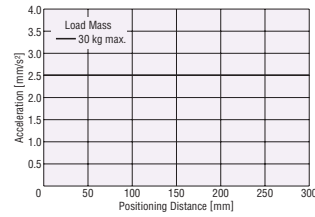

◇ Vertical Installation

● Positioning Distance — Operating Speed

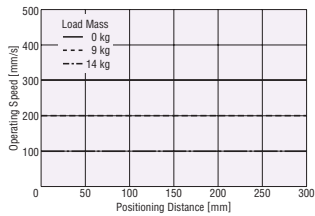

Positioning Distance — Acceleration

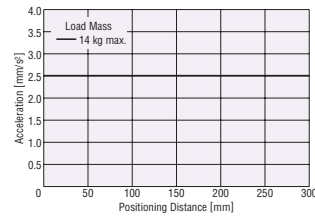

● **EZA6D** (Lead 12 mm, 24 VDC)

◇ Horizontal Installation

● Positioning Distance — Operating Speed

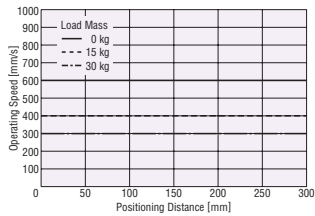

Positioning Distance — Acceleration

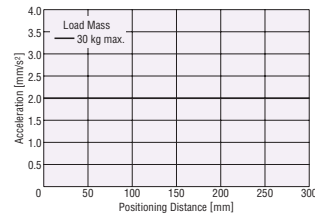

◇ Vertical Installation

● Positioning Distance — Operating Speed

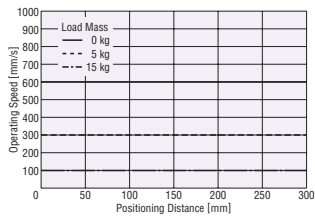

Positioning Distance — Acceleration

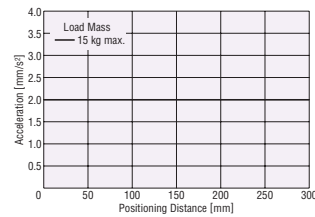

● **EZA6E** (Lead 6 mm, 24 VDC)

◇ Horizontal Installation

● Positioning Distance — Operating Speed

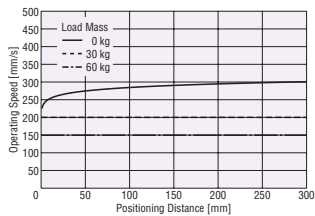

Positioning Distance — Acceleration

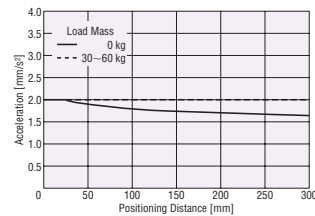

◇ Vertical Installation

● Positioning Distance — Operating Speed

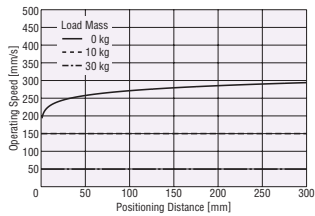

Positioning Distance — Acceleration

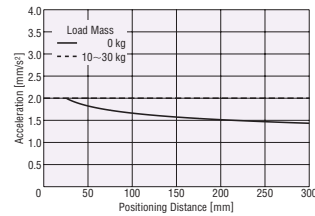

● **EZA6D** (Lead 12mm, Single-Phase 100 VAC/Single-Phase 200-230 VAC)

◇ Horizontal Installation

● Positioning Distance — Operating Speed

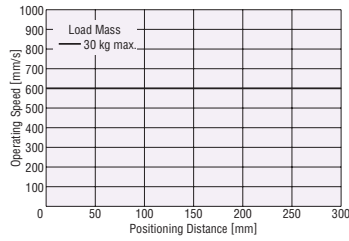

Positioning Distance — Acceleration

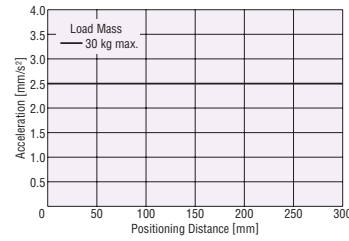

◇ Vertical Installation

● Positioning Distance — Operating Speed

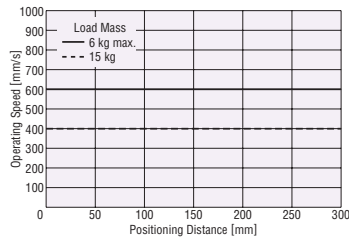

Positioning Distance — Acceleration

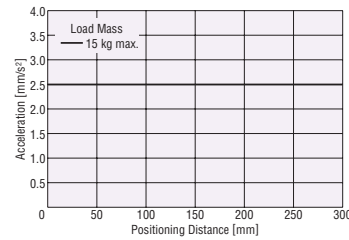

● **EZA6E** (Lead 6 mm, Single-Phase 100 VAC/Single-Phase 200-230 VAC)

◇ Horizontal Installation

● Positioning Distance — Operating Speed

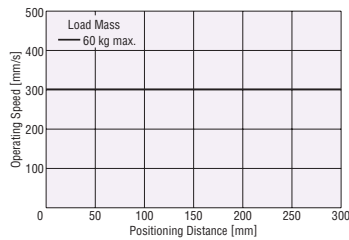

Positioning Distance — Acceleration

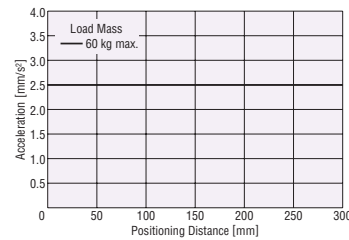

◇ Vertical Installation

● Positioning Distance — Operating Speed



Positioning Distance — Acceleration

