

All-in-One 0.72° Stepper Motor

PKA Series

 Built-in Controller Type

This DC input all-in-one 0.72° stepper motor combines the high performance of a 0.72° stepper motor with a built-in microstepping driver and controller (stored data) type. The built-in controller increases the system configuration flexibility and ease of use.

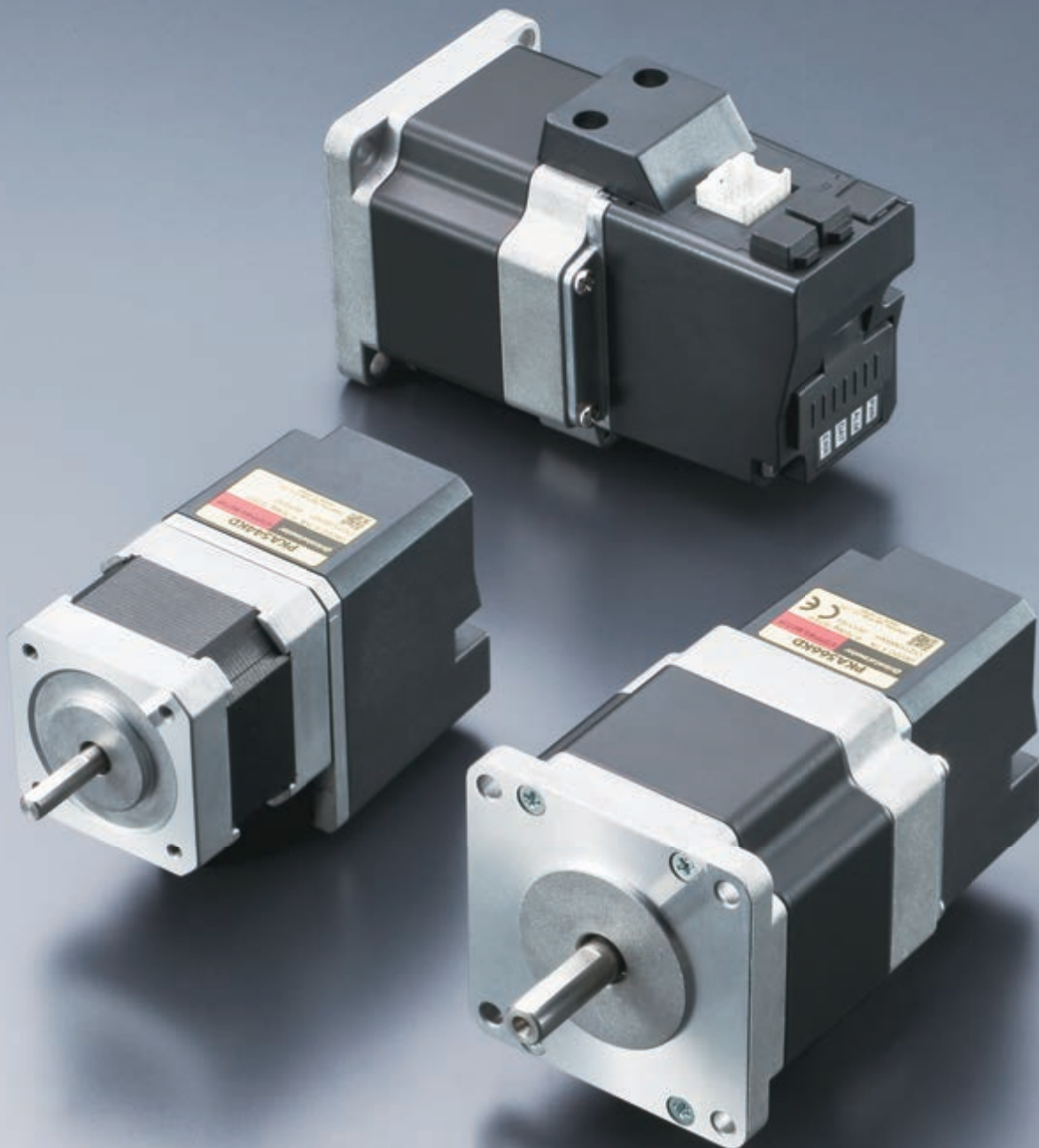

This all-in-one 0.72° stepper motor features a built-in controller (stored data) type, microstepping driver and high performance motor integrated into one compact package.

There is no wiring needed between the controller, driver and motor, providing easy motion control of the high performance 0.72° stepper motor.

There are three control methods that can be selected, I/O, Modbus (RTU)/RS-485 or Factory Automation (FA) Network.

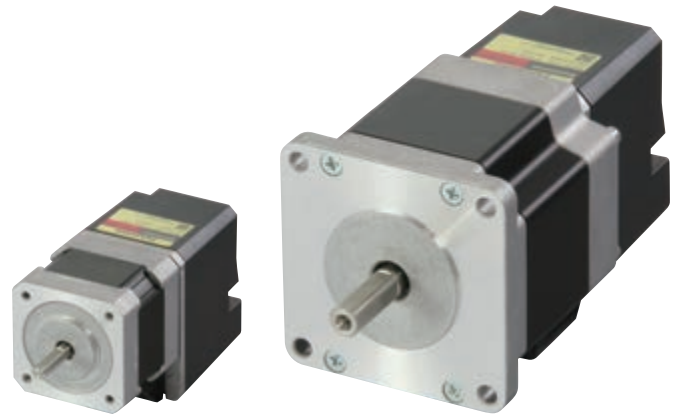

All-in-One Simplifies Motion Control

The controller and driver are integrated onto the 0.72° high performance stepper motor. Since there is a built-in controller there is no need for a pulse generator. The system is simplified and requires less wiring.

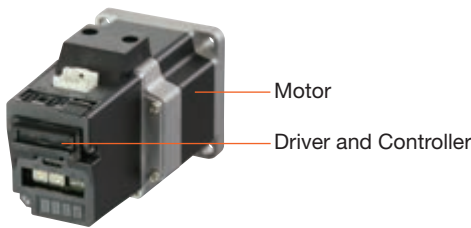

Advantages of the All-in-One High Performance 0.72° Stepper Motor

By combining the high performance motor with a built-in microstepping driver and stored data controller, superior noise and vibration reduction can be easily achieved.

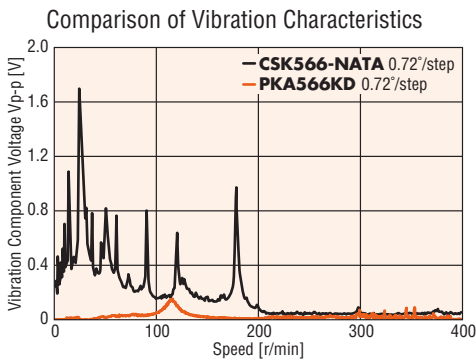

Built-in Controller (Stored Data) Type

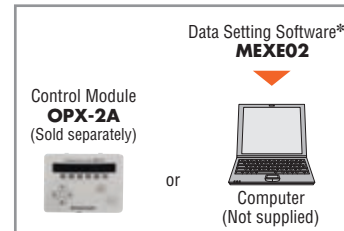

RS-485
Communication

***1 Data Setting Software MEXE02**
 Operating data settings, parameter changes and monitoring are done on a computer.
 Compatible software can be downloaded from the Oriental Motor website.
www.orientalmotor.com

● Operating Status Waveform Monitoring

RS-485
Communication

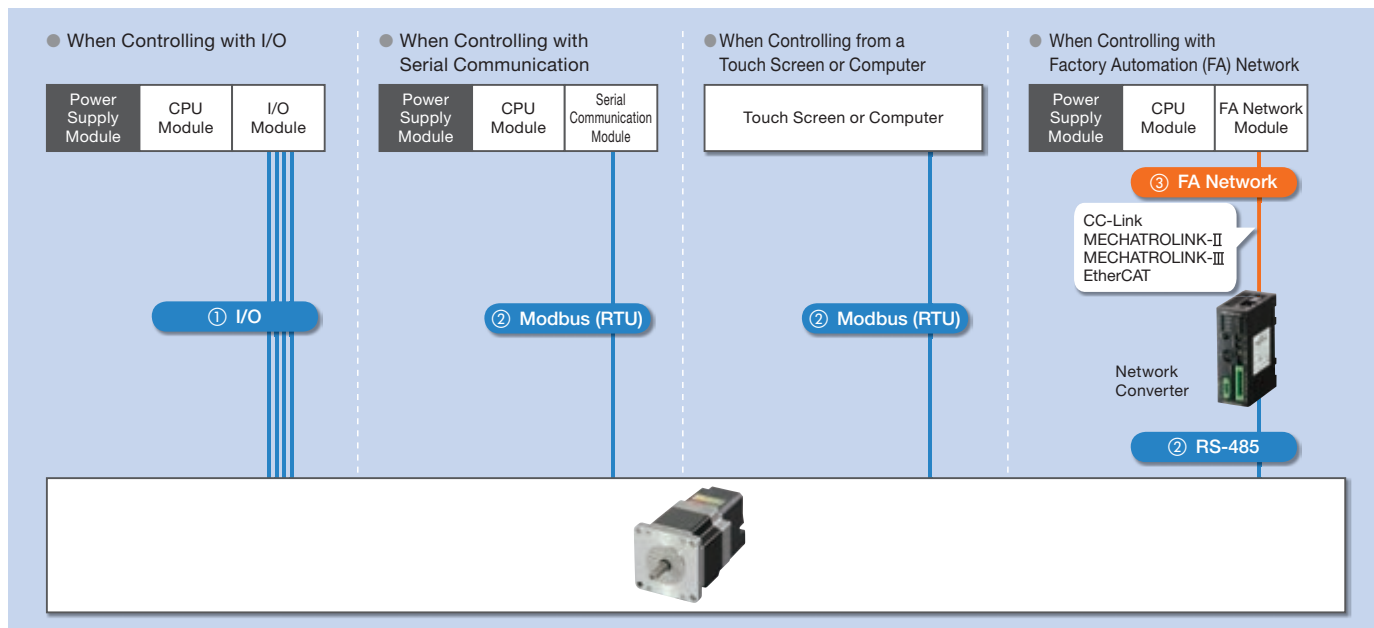

I/O

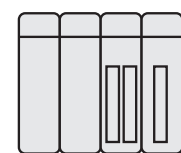

Programmable Controller

The positioning module (pulse generator) function is built-in to the driver, allowing the operation to use I/O by directly connecting to a switch box or PLC. Because a positioning module is not necessary on the PLC side, space is saved and the system is simplified.

Modbus (RTU)/RS-485

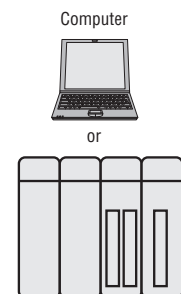

Programmable Controller

Operating data and parameters can be set and operation commands can be input using RS-485 communication. Up to 31 drivers can be connected to each serial communication module. Also, there is a function that enables the simultaneous start of multiple axes. The protocol supports Modbus (RTU), enabling connection with devices such as touch screen (HMI) and PCs.

Factory Automation (FA) Network

Use of a network converter (sold separately)*2 enables support with CC-Link, MECHATROLINK or EtherCAT communication. Operating data and parameters can be set and operation commands can be input using various communication methods.

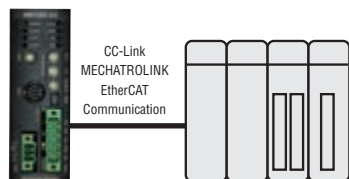

Network Converter Programmable Controller

- NETC01-CC** (Sold separately)
- NETC01-M2** (Sold separately)
- NETC01-M3** (Sold separately)
- NETC01-ECT** (Sold separately)

*2 A network converter converts various network protocols to the RS-485 communication protocol used in Oriental Motor products.

Reduces the Burden on the Master Controller

A positioning function is built-in, ensuring that the traveling amount, speed and other operating data is retained in the motor. It is also equipped with a variety of other operation functions in addition to the positioning operation, such as continuous operation and a return-to-home operation. This contributes to a reduced load on the programmable controller and a simplified program.

● Positioning Operation

The motor's operating speed and traveling amount are set in the operating data and operations are performed in accordance with the selected operating data.

◇ Linked Operation

If the operating data is set to "linked", continuous positioning with the following data number is possible with one START signal.

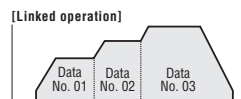

If data No. 01 is selected and the START input, linked driving from data No. 01 to No. 03 is performed without the motor stopping.

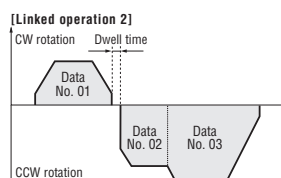

If data No. 01 is selected and the START input, the data No. 01 operation is executed. After that, it is stopped for only the set dwell time* and then the operations from data No. 02 to No. 03 are executed. Operating data with a different rotation direction can also be linked.
* Dwell time is the wait time until the next positioning operation starts.

◇ Sequential Operation

If the operating data is set to "sequential positioning", positioning of the next data number is performed in sequence every time a SSTART signal is input.

● Speed Control Operation

The motor operates continuously while a FWD signal or RVS signal is input. Because it operates at the speed of the operating data set beforehand, multistep speed-change operation is possible by changing the data number.

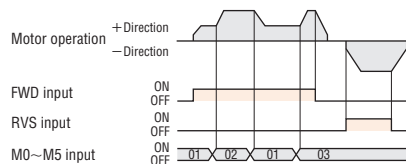

● Return-To-Home Operation

Equipped with a sequence for return-to-home operation that reduces the burden of the host (master controller) and the hassle of combining programs or sequences. A separate sensor is required.

System Configuration

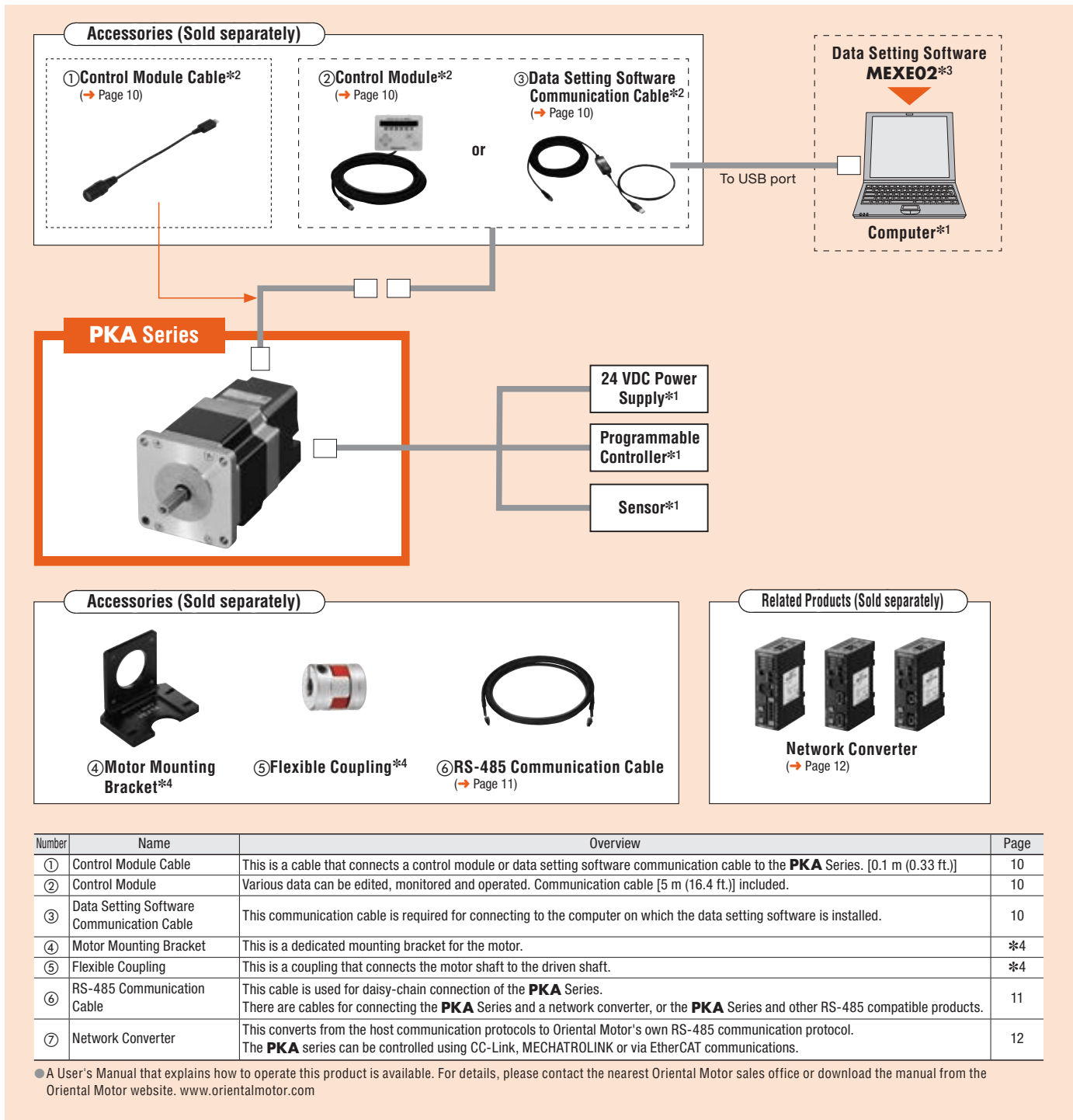

● Example of System Configuration



*1 Not supplied.

*2 This is required for driving I/O control.

*3 Compatible software can be downloaded from the Oriental Motor website.

*4 For details, please contact the nearest Oriental Motor sales office.

● The system configuration shown above is an example. Other combinations are also available.

Product Line

Product Name	List Price
PKA544KD	\$415.00
PKA566KD	\$432.00

Product Name		PKA544KD	PKA566KD
Maximum Holding Torque	N-m (oz-in)	0.18 (25)	0.83 (117)
Holding Torque at Motor Standstill	Power ON N-m (oz-in)	0.09 (12.7)	0.41 (58)
Rotor Inertia	J:kg·m ² (oz-in ²)	54×10 ⁻⁷ (0.3)	280×10 ⁻⁷ (1.53)
Rated Current	A/Phase	0.75	1.4
Basic Step Angle		0.72°	
Power Source		24 VDC±10% 1.4 A	24 VDC±10% 2.5 A
Excitation Mode		Microstep	

Speed – Torque Characteristics

PKA544KD

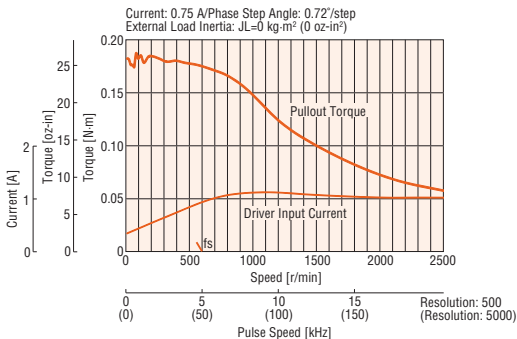

PKA566KD

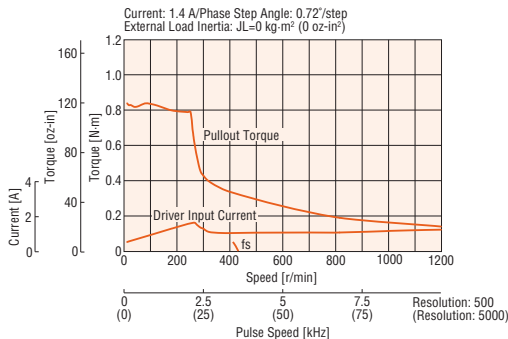

Note

Depending on the driving conditions, a considerable amount of heat may be generated by the motor. Be sure to keep the motor case temperature at 75°C (167°F) max.

Control Circuit Specifications

No. of Positioning Data Sets	64
Operation Functions	Positioning operation, return-to-home operation, continuous operation, JOG operation, test operation

Control Circuit RS-485 Communication Specification

Protocol	Modbus protocol (Modbus RTU mode)
Electrical Characteristics	EIA-485 compliance Twisted-pair wire (TIA/EIA-568B CAT5e or greater recommended) is used up to a total extension length of 50 m (164 ft.).
Sending and Receiving Method	Half-duplex communication
Baud Rate	9600 bps/19200 bps/38400 bps/57600 bps/115200 bps
Physical Layer	Start-stop synchronization method (data: 8-bit, stop bit: 1-bit/2-bit, parity: none/odd/even)
Connection Type	Up to 31 units can be connected to one programmable controller (master controller).

General Specifications

Specifications	Motor	
Heat-Resistant Class	130 (B)	
Insulation Resistance	The measured value is 100 MΩ min. when a 500 VDC megger is applied as follows under normal ambient temperature and humidity: • FG terminal and motor case — Between power input terminals	
Dielectric Strength	No abnormality is found with the following application for 1 minute under normal ambient temperature and humidity: • FG terminal and motor case — Between power input terminals 500 VAC 50 Hz or 60 Hz	
Operating Environment (In operation)	Ambient Temperature	0~50°C (+32~+122°F) (non-freezing)
	Ambient Humidity	85% max. (non-condensing)
	Atmosphere	Use in an area without corrosive gases and dust. The product should not be exposed to water, oil or other liquids.
Degree of Protection	IP20	
Temperature Rise	Temperature rise of the windings are 80°C (176°F) max. (measured by the resistance change method) at the rated current, at standstill, and 5-phases energized.	
Stop Position Accuracy ^{*1}	±3 arc minutes (±0.05°)	
Shaft Runout	0.05 mm (0.002 in.) T.I.R. ^{*4}	
Radial Play ^{*2}	0.025 mm (0.001 in.) Maximum of 5 N (1.12 lb.)	
Axial Play ^{*3}	0.075 mm (0.003 in.) Maximum of 10 N (2.2 lb.)	
Concentricity of Installing Pilot to the Shaft	0.075 mm (0.003 in.) T.I.R. ^{*4}	
Perpendicularity of Installation Surface to the Shaft	0.075 mm (0.003 in.) T.I.R. ^{*4}	

*1 This value is for full step under no load. (The value changes with the size of the load.)

*2 Radial Play: Displacement in shaft position in the radial direction, when a 5 N (1.12 lb.) load is applied in the vertical direction to the tip of the motor's shaft.

*3 Axial Play: Displacement in shaft position in the axial direction, when a 10 N (2.2 lb.) load is applied to the motor shaft in the axial direction.

*4 T. I. R. (Total Indicator Reading): The total dial gauge reading when the measurement section is rotated one revolution centered on the reference axis center.

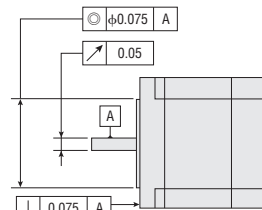

Permissible Overhung Load and Permissible Thrust Load

Unit N (lb.)

Motor Frame Size	Product Name	Max. Permissible Overhung Load Distance from Shaft End mm [in.]					Permissible Thrust Load
		0 [0]	5 [0.2]	10 [0.39]	15 [0.59]	20 [0.79]	
42 mm [1.65 in.]	PKA544KD	20 (4.5)	25 (5.6)	34 (7.6)	52 (11.7)	—	Motor Self-Weight max.
60 mm [2.36 in.]	PKA566KD	63 (14.1)	75 (16.8)	95 (21)	130 (29)	190 (42)	

Dimensions Unit mm (in.)

Motor

Frame Size 42 mm (1.65 in.)

Product Name	Mass kg (lb.)	CAD
PKA544KD	0.37 (0.81)	B798

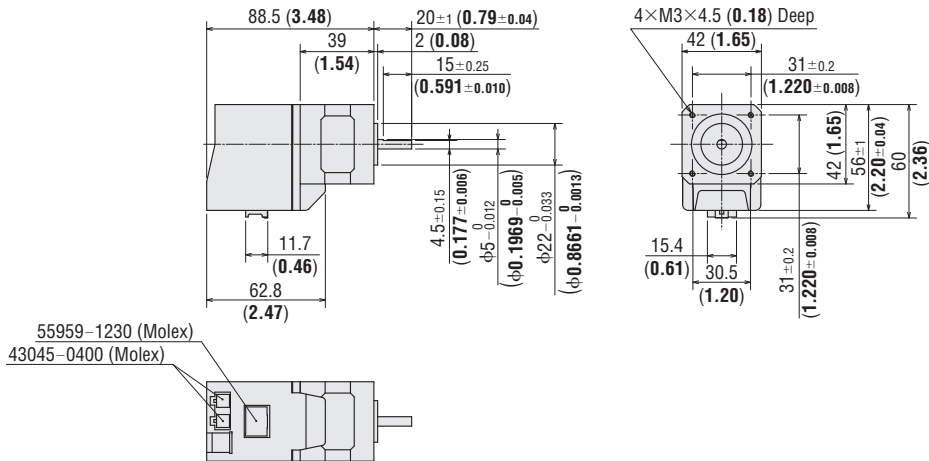

Frame Size 60 mm (2.36 in.)

Product Name	Mass kg (lb.)	CAD
PKA566KD	0.89 (1.96)	B799

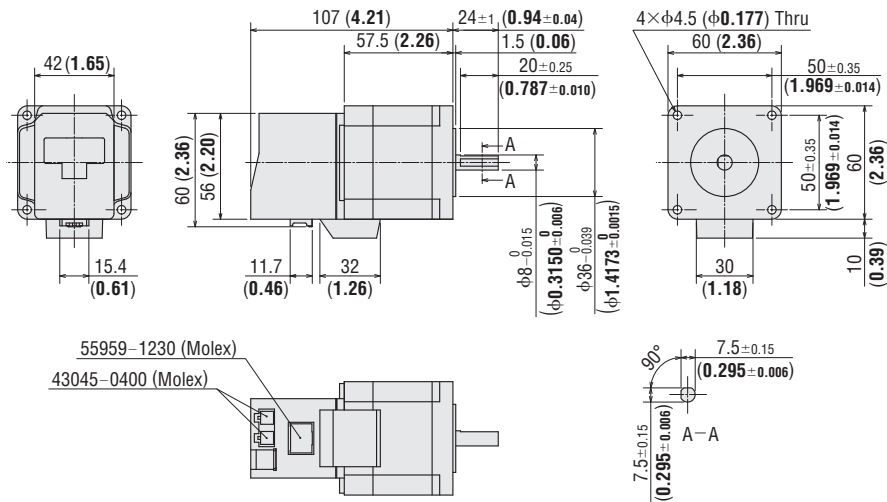

Connection Cable (Included)

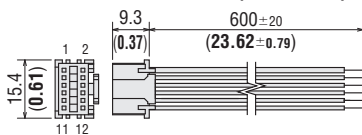

Connection and Operation

Names and Function of Parts

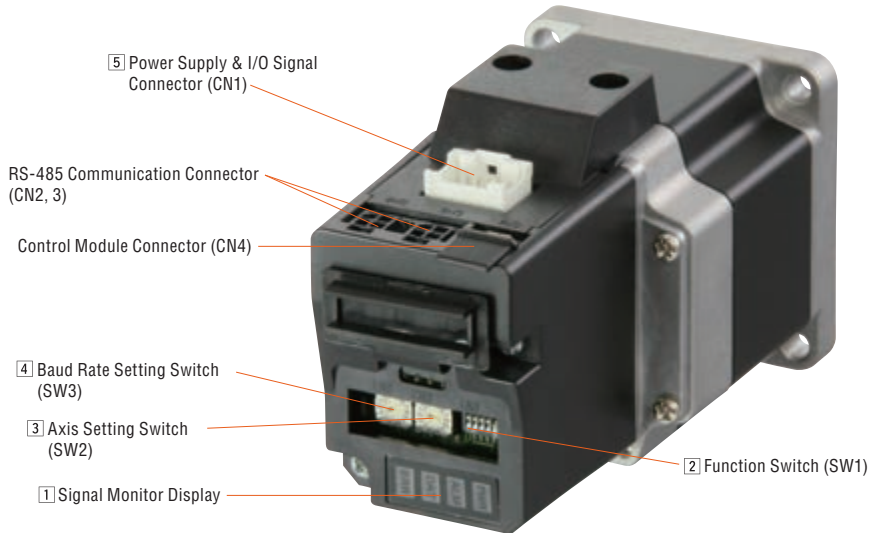

1 Signal Monitor Display

◇ LED Indicator

Indication	Color	Function	Lighting Condition
PWR	Green	Power Supply Indication	When the power supply is input
ALM	Red	Alarm Indication	When a protective function is activated (blinking)
DAT	Green	Communication Indication	When data is being received or sent
ERR	Red	Communication Error Indication	When a communication error has occurred

2 Function Switch (SW1)

Indication	No.	Function
SW1	1, 2	Sets the terminating resistor for RS-485 communication (120 Ω) (factory setting: OFF). OFF: Terminating resistor not used ON: Terminating resistor used
	3	Sets the model number in combination with the model setting switch (SW2) (factory setting: OFF).
	4	Sets the protocol for RS-485 communication (factory setting: OFF).

◇ Settings for RS-485 Communication Protocol

Destination No.	Network Converter Connection	Modbus RTU Mode
	4	OFF

3 Axis Setting Switch (SW2)

Indication	Function
SW2	Set when using with RS-485 communication. Set the axis number (factory setting: 0).

4 Baud Rate Setting Switch (SW3)

Indication	Function
SW3	Set when using with RS-485 communication. Set the baud rate (factory setting: 7).

◇ RS-485 Baud Rate Setting

No.	Baud Rate (bps)
0	9600
1	19200
2	38400
3	57600
4	115200
5~6	Not used
7	625000 Connect with a network converter
8~F	Not used

5 Power Supply & I/O Signal Connector (CN1)

Indication	Pin No.	Signal Name	Content
CN1	1	FG	Frame ground
	2	GND	Power supply GND
	3	IN-COM	Input common
	4	+24 VDC	+24 VDC power supply input
	5	INO	Control input 0 (initial value: +LS)*
	6	IN1	Control input 1 (initial value: -LS)*
	7	IN2	Control input 2 (initial value: HOMES)*
	8	IN3	Control input 3 (initial value: STOP)*
	9	OUT0+	Control output 0 (initial value: ALM)*
	10	OUT0-	
	11	OUT1+	Control output 1 (initial value: READY)*
	12	OUT1-	

*Sets the function to be assigned according to the parameter setting. The initial values are shown above. For details, refer to the User's Manual.

The following input signals can be assigned to input terminals IN0~3.

Input Signal					
0: Not used	8: MS0	18: STOP	36: R4	44: R12	52: M4
1: FWD	9: MS1	24: ALM-RST	37: R5	45: R13	53: M5
2: RVS	10: MS2	25: P-PRESET	38: R6	46: R14	60: +LS
3: HOME	11: MS3	27: HMI	39: R7	47: R15	61: -LS
4: START	12: MS4	32: R0	40: R8	48: M0	62: HOMES
5: SSTART	13: MS5	33: R1	41: R9	49: M1	63: SLIT
6: +JOG	16: FREE	34: R2	42: R10	50: M2	
7: -JOG	17: AWO	35: R3	43: R11	51: M3	

The following output signals can be assigned to output terminal OUT0~1.

Output Signal					
0: Not used	9: MS1_R	33: R1	42: R10	51: M3_R	67: READY
1: FWD_R	10: MS2_R	34: R2	43: R11	52: M4_R	68: MOVE
2: RVS_R	11: MS3_R	35: R3	44: R12	53: M5_R	70: HOME-P
3: HOME_R	12: MS4_R	36: R4	45: R13	60: +LS_R	72: TIM
4: START_R	13: MS5_R	37: R5	46: R14	61: -LS_R	73: AREA1
5: SSTART_R	16: FREE_R	38: R6	47: R15	62: HOMES_R	74: AREA2
6: +JOG_R	17: AWO_R	39: R7	48: M0_R	63: SLIT_R	75: AREA3
7: -JOG_R	18: STOP_R	40: R8	49: M1_R	65: ALM	80: S-BSY
8: MS0_R	32: R0	41: R9	50: M2_R	66: WNG	

● Connection Diagram

◇ Connection to Programmable Controller

● Example of Connection with Current Sink Output Circuit (NPN specification)

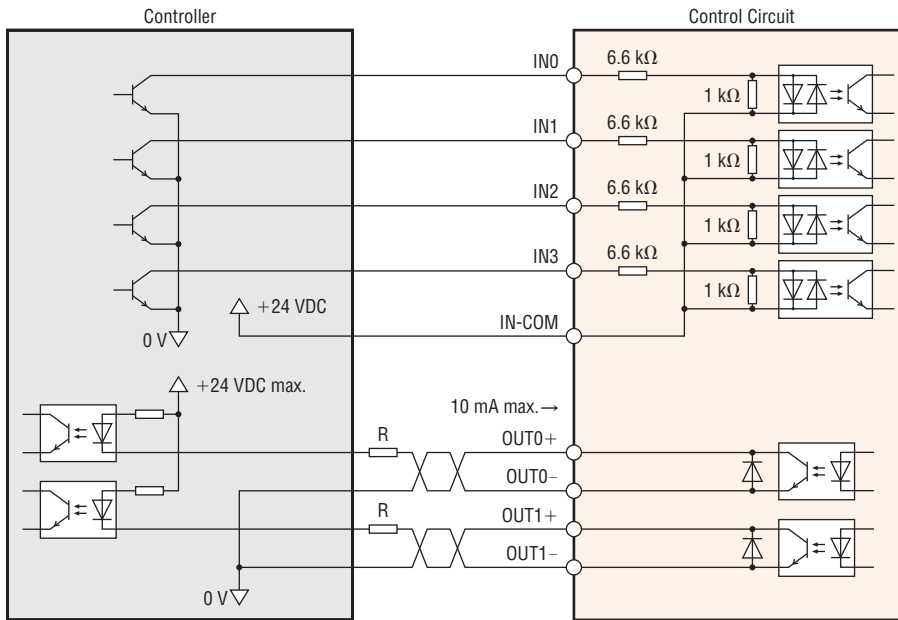

● Example of Connection with Current Source Output Circuit (PNP specification)

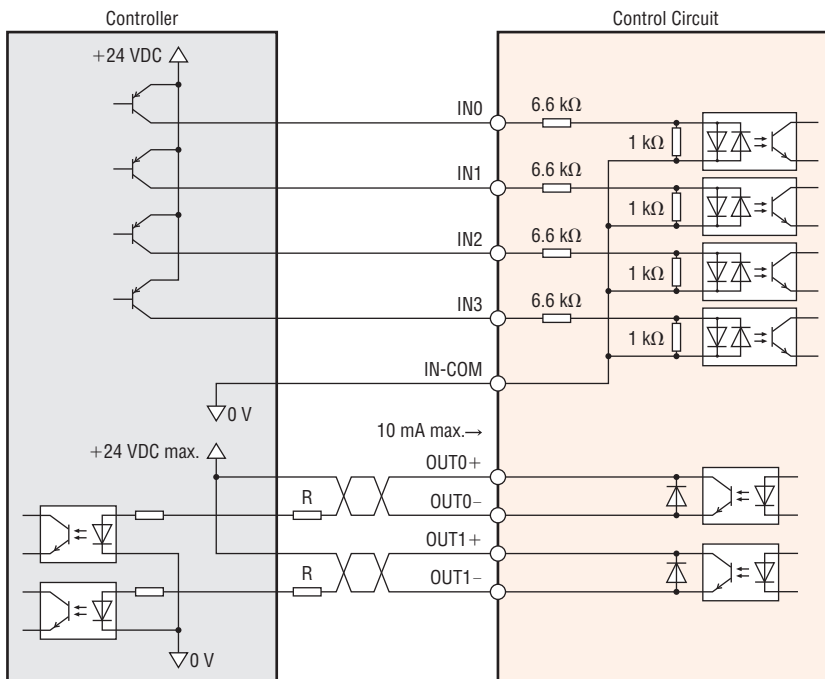

Notes

- Use 24 VDC for the input signals.
- Use 24 VDC 10 mA max. for the output signals. When the current value exceeds 10 mA, connect the external resistor R to keep the current 10 mA max.
- If noise generated by the power supply cable causes a problem with the specific wiring or layout, shield the cable or use ferrite cores.

Accessories (Sold separately)

These accessories are necessary to change operating data such as parameter settings and data settings in the **PKA Series**.

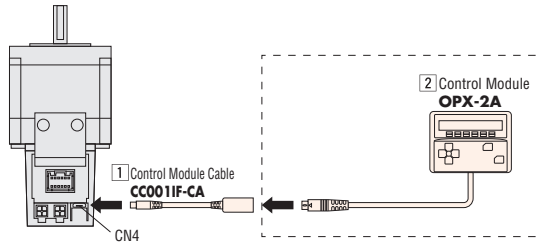

1 Control Module Cable RoHS

This is a cable that connects an **OPX-2A** or data setting software communication cable to the **PKA Series**.

Product Line

Product Name	List Price
CC001F-CA	\$9.00

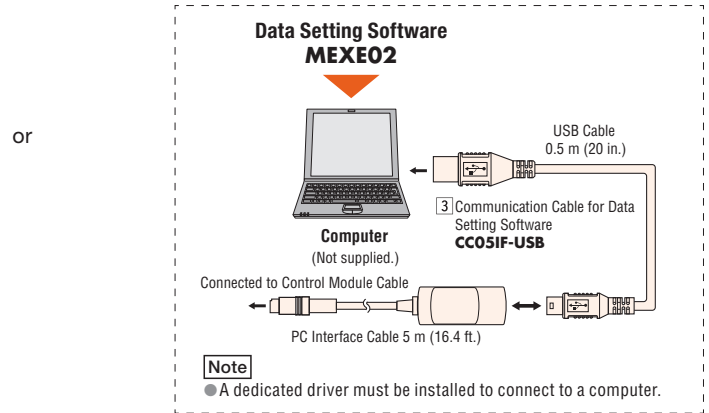

2 Control Module RoHS

Perform operations such as setting the driver's internal parameters and setting or changing the data. It can also be used for operations such as speed and I/O monitoring and teaching.

Product Line

Product Name	List Price
OPX-2A	\$300.00

Specifications

Indication	LED
Cable Length	5 m (16.4 ft.)
Operating Ambient Temperature	0~40°C (+32~+104°F) (non-freezing)

Dimensions unit mm (in.)

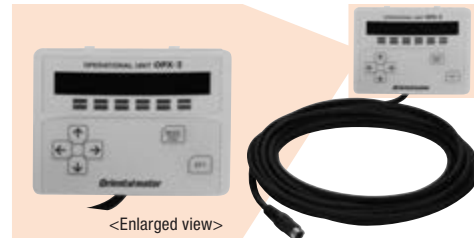
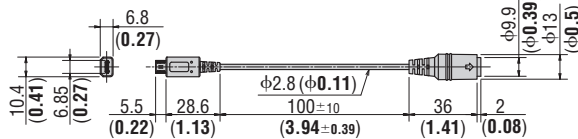

Dimensions Unit mm (in.)

● Control Module
Mass: 0.25 kg (0.55 lb.)
CAD B453

● Panel Cut-Out for Controller Module
[Installation Plate Thickness 1~3 mm (0.04~0.12 in.)]

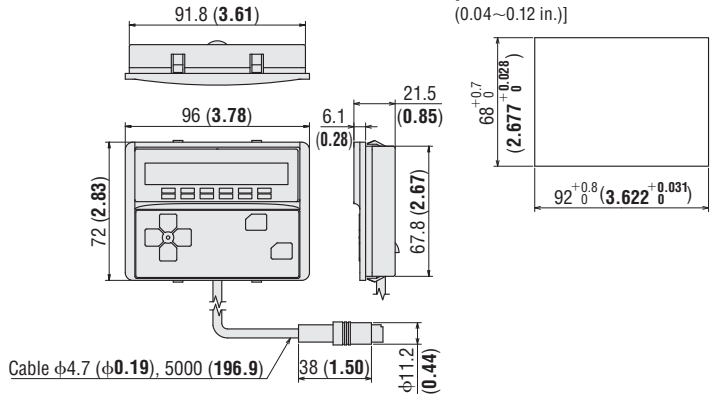

3 Data Setting Software Communication Cable RoHS

This communication cable is required for connecting to the computer on which the data setting software is installed.

Product Line

Product Name	List Price
CC05IF-USB	\$120.00



Data Setting Software MEXE02

The data setting software can be downloaded from the Oriental Motor website. www.orientalmotor.com
For details, please go to the Oriental Motor website or contact the nearest Oriental Motor sales office.

Operating Environment

Operating System (OS)

- Microsoft Windows 2000 Professional Service Pack 4
Be sure to install Rollup 1 provided by Microsoft Corporation.
Check whether Rollup 1 has been installed in "Add or Remove Programs".

For the following operating systems, both the 32-bit (x86) edition and 64-bit (x64) edition are supported.

- Microsoft Windows XP Home Edition Service Pack 3
- Microsoft Windows XP Professional Service Pack 2
- Microsoft Windows XP Professional Service Pack 3*1
- Microsoft Windows Vista Home Basic Service Pack 2
- Microsoft Windows Vista Home Premium Service Pack 2
- Microsoft Windows Vista Business Service Pack 2
- Microsoft Windows Vista Ultimate Service Pack 2
- Microsoft Windows Vista Enterprise Service Pack 2
- Microsoft Windows 7 Starter Service Pack 1
- Microsoft Windows 7 Home Premium Service Pack 1
- Microsoft Windows 7 Professional Service Pack 1
- Microsoft Windows 7 Ultimate Service Pack 1
- Microsoft Windows 7 Enterprise Service Pack 1

*1 32-bit (x86) version only

PC

Recommended CPU*2	Intel Core processor 2 GHz min. (Must be compatible with OS)
Display	Video adapter and monitor with resolution of XGA (1024 × 768) min.
Recommended Memory*2	32-bit version (x86): 1 GB min. 64-bit version (x64): 2 GB min.
Hard Disk*3	Free disk space of 30 MB min.
USB Port	USB 1.1 1 Port
Disk Device	CD-ROM Drive (Used for installation)

*2 The operating conditions of the OS must be satisfied.

*3 Microsoft .NET Framework 2.0 Service Pack 2 is required for **MEXE02**. If it is not installed, it will be installed automatically. An additional max. of 500 MB of free space may be required.

Notes

- The required memory and hard disk space may vary depending on the system environment.
- Windows and Windows Vista are registered trademarks of the Microsoft Corporation in the United States and other countries.

RS-485 Communication Cable

This is an RS-485 communication cable.



CC020-RS4A



CC020-RS4B

Product Line

Product Name	Overview	Length m (ft.)	List Price
CC020-RS4A	This cable is used for daisy-chain connection of the PKA Series.	2 (6.6)	\$35.00
CC020-RS4B	There are cables for connecting the PKA Series and a network converter, or the PKA Series and other RS-485 compatible products.	2 (6.6)	\$50.00

Dimensions unit mm (in.)

CC020-RS4A

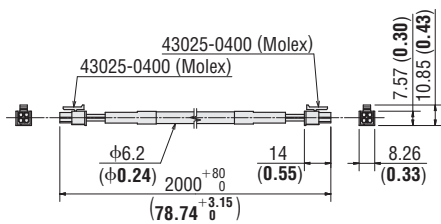

CC020-RS4B

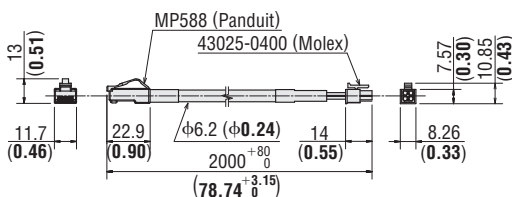

Connection Example

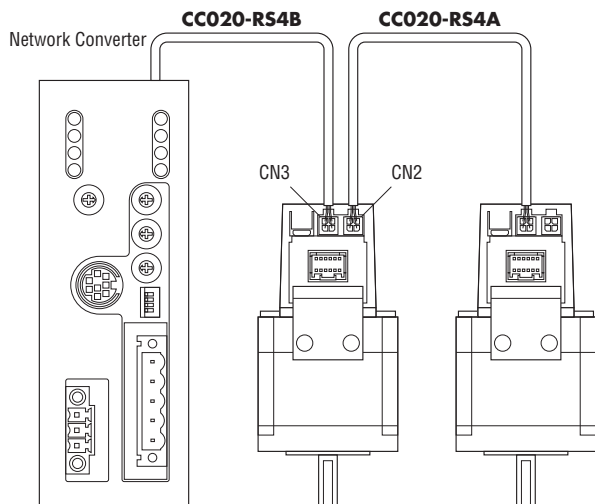

Related Products (Sold separately)

Network Converter RoHS

A network converter converts from the host communication protocols to Oriental Motor's own RS-485 communication protocol. Use the network converter to control products supporting Oriental Motor's RS-485 compatible products in the host communication environment.

Features

● Reduced Wiring and Space Saving is Possible

Only the one included cable is needed for the wiring when connecting to an RS-485-compatible product.

● Setting Method for Various Parameters

A control module **OPX-2A** (sold separately) or data setting software **MEXE02** is required for setting a network converter. A control module **OPX-2A** and data setting software **MEXE02** can also be used to monitor the time it takes to communicate with each axis.

● Multi-axis Connection is Possible

RS-485-compatible products can be connected on multiple axes.

- CC-Link-compatible: 12 axes max.
- MECHATROLINK-II-compatible: 16 axes max.
- MECHATROLINK-III-compatible: 16 axes max.
- EtherCAT-compatible: 16 axes max.



Product Line

Network Product Line	Product Name	List Price
CC-Link-compatible	NETC01-CC	\$282.00
MECHATROLINK-II-compatible	NETC01-M2	\$358.00
EtherCAT-compatible	NETC01-ECT	\$510.00

The following items are included in each product.
 Network converter, RS-485 communication cable, power supply connector, operating manual, CC-Link communication connector (**NETC01-CC** only)

Specifications are subject to change without notice. This catalog was published in May, 2013.

ORIENTAL MOTOR U.S.A. CORP.

Western Sales and Customer Service Center

Tel: (310) 715-3301 Fax: (310) 225-2594

Los Angeles

Tel: (310) 715-3301

San Jose

Tel: (408) 392-9735

Midwest Sales and Customer Service Center

Tel: (847) 871-5900 Fax: (847) 472-2623

Chicago

Tel: (847) 871-5900

Dallas

Tel: (214) 432-3386

Toronto

Tel: (905) 502-5333

Eastern Sales and Customer Service Center

Tel: (781) 848-2426 Fax: (781) 848-2617

Boston

Tel: (781) 848-2426

Charlotte

Tel: (704) 766-1335

New York

Tel: (973) 359-1100

Technical Support

Tel: (800) 468-3982 / 8:30 A.M. to 5:00 P.M., P.S.T. (M-F)
 7:30 A.M. to 5:00 P.M., C.S.T. (M-F)

E-mail: techsupport@orientalmotor.com

**Obtain Specifications, Online Training
 and Purchase Products at:**
www.orientalmotor.com

Copyright ©2013 ORIENTAL MOTOR U.S.A. CORP.

This printed material uses ECF (Elementary Chlorine Free) paper and vegetable oil based inks. This combination is environmentally friendly.

Printed in USA 13S #419