

Stepping Motors

Stepping Motors (Motor Only)

	Introduction	AC Input Motor & Driver	DC Input Motor & Driver	Motor Only	Controllers SCX10 EMP400 /5G8030J	Accessories	
	<i>D_{STEP}</i> AR	0.36° / Geared	0.36° / Geared				PK
	<i>D_{STEP}</i> AS	0.72° / Geared	0.36° / Geared				PK
	RK	0.9°/1.8°	0.36°/0.72° / Geared				PK
	UMK	0.9°/1.8°	0.9°/1.8° / Geared				PK/PV
	<i>D_{STEP}</i> AR	0.36° / Geared	1.8° / Geared				Geared PK
	<i>D_{STEP}</i> ASX	0.36° / Geared					
	CRK						
	CMK						
	RBK						
	0.36° PK Series						
	0.72° PK Series						
	0.9° PK Series						
	1.8° PK/PV Series						
	Geared Type PK Series						

Stepping Motors (Motor Only)

● Additional Information ●
 Technical reference → Page G-1
 Safety standards → Page H-2

Four basic step angles are available. A wide range of frame sizes are also available from 20 mm (0.79 in.) up to 85 mm (3.35 in.). Five geared solutions are available in the same frame sizes up to 90 mm (3.54 in.) and come pre-assembled. Encoder options are also available as a standard offering. Motor windings come in various specifications.

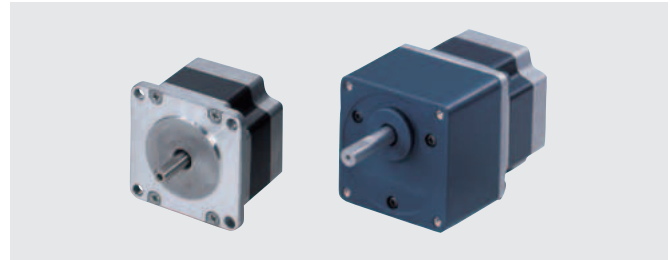

Features

● Four Basic Step Angles are Available

- 0.36°: High-Torque type
- 0.72°: High-Torque or Standard type
- 0.9°: Standard type
- 1.8°: High-Torque, High-Efficiency, Standard type or High-Inertia Capability

◇ 0.36° Stepping Motors: High-Torque Type

The 0.36° Stepping Motors, High-Torque type provides 1000 steps per revolution by having 100 teeth on the rotor and contributes to the highest resolution and lowest vibration. This motor also achieves improved stopped positional accuracy of 2 arc minutes.

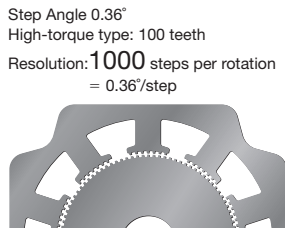

● Lowest Vibration

The lowest vibration is achieved using the smallest basic step angle of 0.36°.

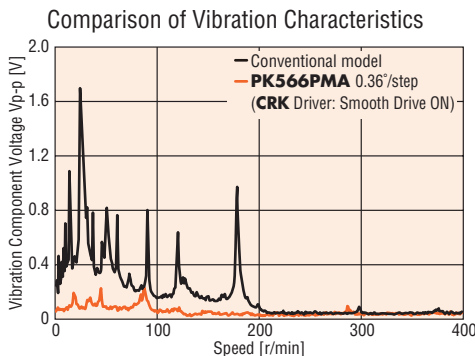

● Stop Position Accuracy of 2 Arc Minutes (No Load)

The step angle 0.36° high-torque type is designed with a stop position accuracy of 2 arc minutes (0.034°) [standard type: 3 arc minutes (0.05°)]. The reduced error helps improve the positioning accuracy.

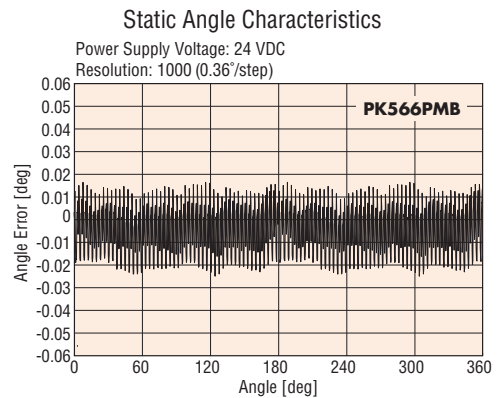

◇ 0.72° Stepping Motors: High-Torque and Standard Type

The 0.72° Stepping Motors, High-Torque or Standard type offer 500 steps per revolution and providing excellent performance. The 0.72° motors are ideal for reducing the vibration throughout the entire motor speed range.

◇ 0.9° Stepping Motors: Standard Type

The 0.9° Stepping Motors, Standard type provides 400 steps per revolution.

◇ 1.8° Stepping Motors: High-Torque and Standard Type

The 1.8° Stepping Motors, High-Torque or Standard type offers 200 steps per revolution.

● Five Geared Types

Five different gearheads are offered in our Geared Motors, each designed for different characteristics and specifications based on varying applications or motion requirements. Please see page A-275 for details.

● High-Torque Type

(Step Angle 0.36°, 0.72°, 1.8°)

◇ Generates a High-Torque

A high-torque motor generating high torque of approx. 1.2 to 1.5 times the level achieved by the standard type.

Comparison of Speed-Torque Characteristics for the Same Motor Frame Size

1.8° High-Torque Type

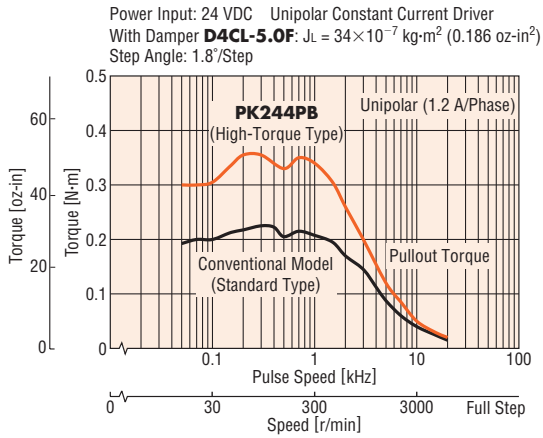

◇ Downsizing of Your Motor

Providing torque equivalent to a motor of the next larger frame size, high-torque type allows for a downsizing of your equipment.

Example: Comparison of 1.8° Standard Type and 1.8° High-Torque Type

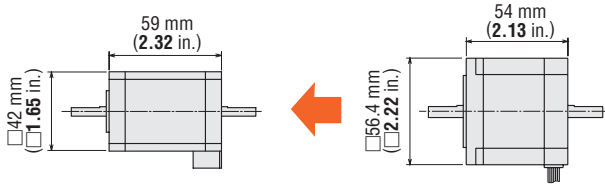

High-Torque Type	Type	Standard Type
PK246PB	Model	PK266-01B
0.93 N-m (132 oz-in)	Holding Torque	1.17 N-m (166 oz-in)

◇ Lower Power Consumption and Lower Heat Generation

When compared to the standard type, the motor current may drop at equivalent torque due to an excess in the torque. This may have the effect of reducing the temperature rise of the motor.

● High-Torque, High-Efficiency Type

(Step Angle 1.8°)

◇ Lower Heat Generation

Utilizing the latest in motor technology, the High-Torque, High-Efficiency Type stepping motors are able to achieve a significant reduction in the amount of heat generated from the motor. (There is a 50% reduction in temperature rise compared with conventional models.)

Motor Case Temperature under the Same Operating Conditions

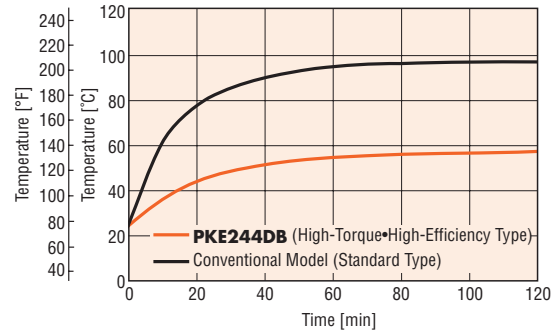

Temperature Distribution by Thermography

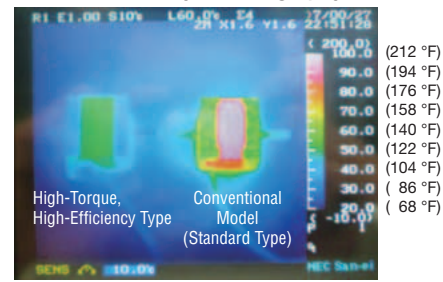

● Comparison under the Same Operating Conditions

◇ Lower Power Consumption

This model has achieved a 31% reduction* in power consumption through energy savings and a reduction of 10 kg/per year in CO₂ emissions.

Power Consumption

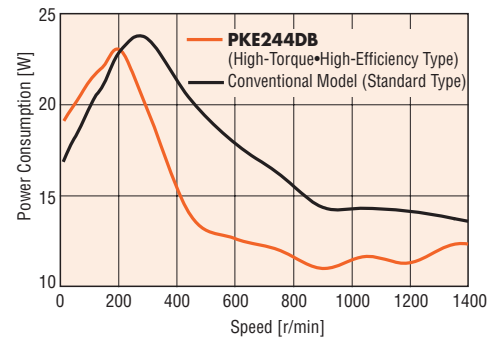

*450 r/min, continuous operation

- Introduction
- DC Input Motor & Driver
 - AR 0.36°/Geared
 - AS 0.72°/Geared
 - UMK 0.9°/1.8°
 - AR 0.36°/Geared
 - ASX 0.36°/Geared
 - CRK 0.36°/0.72°/Geared
 - CMK 0.9°/1.8°/Geared
 - RBK 1.8°/Geared
- Motor Only
 - PK 0.36°
 - PK 0.72°
 - PK 0.9°
 - PK/PV 1.8°
 - PK Geared
- Controllers
 - SCX10
 - EMP400
 - /SG80301
- Accessories

● **Encoder Option Available**
(Step Angle 0.36°, 0.72°, 0.9°, 1.8°)



The **PK** Series stepping motor with encoder offers high torque and precise feedback capability.

- Encoder Feedback Type: Incremental
- Encoder Output Type: TTL and Differential Type*
- Four feedback resolutions: 200, 400, 500 and 1000 pulses/rev*
- 2-channel or 3-channel*
- Provides closed loop system capability

*For details on the Encoder product lineup, check the Product Line on A-282.

● **Terminal Box Type**
(Step Angle 0.72°, 1.8°)

The motor conforms to the IP65 standard of ingress protection against dust and water.

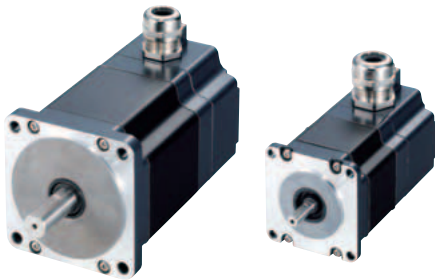

◇ **Terminal-Block Connection Design**

The motor can be wired directly from its terminal block.

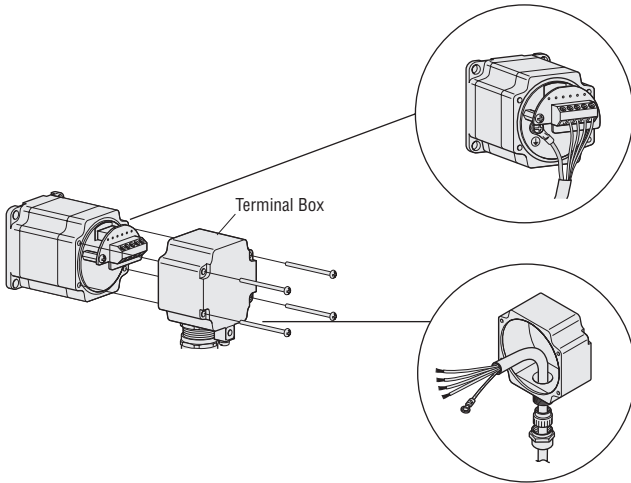

● **PV Series**
(Step Angle 1.8°)

◇ **High Inertia Capability**

The **PV** Series provides, on average, 1.5 times higher torque than a standard stepping motor. By utilizing a larger rotor diameter, larger magnets can be used to significantly increase the output torque.

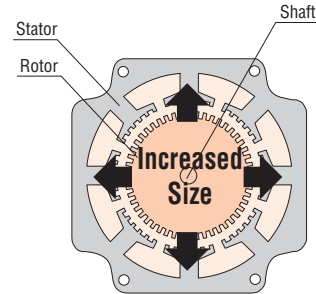



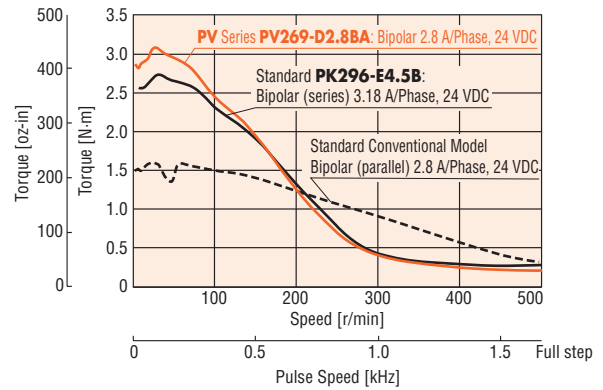

Motor structure
(Cross section perpendicular to shaft)



● Geared Motor Lineup

◇ Characteristics Comparison for Geared Motors























Geared Type	Features	Permissible Torque Maximum Torque [N·m (lb-in)]	Backlash [arc min (degrees)]	Basic Resolution [deg/step]	Output Shaft Speed [r/min]
For 1.8° Stepping Motor	SH Geared Type (Parallel shaft)  <ul style="list-style-type: none"> A wide variety of low gear ratios, high-speed operations Gear ratios: 3.6, 7.2, 9, 10, 18, 36 	12 (106)	Approx. 60~120 (1~2)	0.05	500
	TH Geared Type (Parallel shaft)  <ul style="list-style-type: none"> A wide variety of low gear ratios, high-speed operations Gear ratios: 3.6, 7.2, 10, 20, 30 	12 (106)	45 (0.75)	0.024	500
Low backlash	PS/PL Geared Type (Parallel shaft)  <ul style="list-style-type: none"> High permissible/maximum torque A wide variety of gear ratios for selecting the desired step angle (resolution) Centered output shaft Gear ratios: 5, 7.2, 10, 25, 36, 50 	Permissible Torque 37 (320) Maximum Torque 60 (530)	25 (0.42)	0.0144	600
	PN Geared Type (Planetary)  <ul style="list-style-type: none"> High speed (low gear ratio), high accuracy positioning High permissible/maximum torque A wide variety of gear ratios for selecting the desired step angle (resolution) Centered output shaft Gear ratios: 5, 7.2, 10, 25, 36, 50 	Permissible Torque 37 (320) Maximum Torque 60 (530)	3 (0.05)	0.0144	600
Non-backlash	Harmonic Geared Type (Harmonic drive)  <ul style="list-style-type: none"> High accuracy positioning High permissible/maximum torque High gear ratios, high resolution Centered output shaft Gear ratios: 50, 100 	Permissible Torque 37 (320) Maximum Torque 55 (480)	0	0.0072	70

Note

● The values shown above are for reference only. These values vary depending on the frame size and gear ratio.





















Introduction	AC Input Motor & Driver	DC Input Motor & Driver	Motor Only	Controllers	Accessories
AR DSTEP AS	0.36° / Geared 0.72° / Geared	0.36° / Geared 0.36° / Geared	PK	SCX10 EMP400 /SG8030J	
RK	0.9° / 1.8°	0.9° / 1.8° / Geared	PK		
UMK	0.9° / 1.8°	0.9° / 1.8° / Geared	PK / PV		
AR DSTEP	0.36° / Geared	0.36° / Geared	PK		
ASX	0.36° / Geared	0.36° / Geared	PK		
CRK	0.36° / 0.72° / Geared	0.36° / 0.72° / Geared	PK		
CMK	0.9° / 1.8° / Geared	0.9° / 1.8° / Geared	PK		
RBK	1.8° / Geared	1.8° / Geared	PK		
PK	0.36°	0.36°	PK		
PK	0.72°	0.72°	PK		
PK	0.9°	0.9°	PK		
PK / PV	1.8°	1.8°	PK / PV		
PK	Geared	Geared	PK		

Wide Range of Stepping Motor Variations

Motor Frame Size [mm (in.)]	Round Shaft							
20 (0.79)	0.72° High-Torque	1.8° High-Torque						
								
	Page A-291	Page A-304						
28 (1.10)	0.36° High-Torque	0.72° High-Torque	1.8° High-Torque					
								
	Page A-290	Page A-291	Encoder Page A-305					
35 (1.38)	1.8° High-Torque							
								
	Encoder Page A-307							
42 (1.65)	0.36° High-Torque	0.72° High-Torque	0.72° Standard	0.9° Standard	1.8° High-Torque, High-Efficiency	1.8° High-Torque	1.8° Standard Type	
								
	Encoder Page A-290	Encoder Page A-291	Encoder Page A-291	Encoder Page A-294	Page A-302	Encoder Page A-309	Encoder Page A-313	
	1.8° Standard							
								
	Encoder Page A-317							
	56.4 (2.22) 60 (2.36)	0.36° High-Torque	0.72° Standard	0.9° Standard	1.8° High-Torque	1.8° Standard	1.8° PV Series	
								
Encoder Page A-290		Terminal Box Encoder Page A-292, A-293	Encoder Page A-298	Encoder Page A-311	Terminal Box Encoder Page A-319, A-323	Page A-325		
0.72° Standard		1.8° Standard						
								
Terminal Box Encoder Page A-292, A-293		Terminal Box Encoder Page A-328, A-332						

Encoder Motor with an encoder is available

Terminal Box Motor with Terminal Box is available

Motor Frame Size [mm (in.)]	Geared				
20 (0.79)	Harmonic Geared				
					
	Page A-354				
28 (1.10)	SH Geared	TH Geared	PS Geared	PN Geared	Harmonic Geared
					
	Encoder Page A-334	Page A-342	Page A-344, A-346	Page A-352	Page A-354
35 (1.38)					
42 (1.65)	SH Geared	TH Geared	PS, PL Geared	PN Geared	Harmonic Geared
					
	Encoder Page A-336	Encoder Page A-342	Encoder Page A-344, A-348	Page A-352	Encoder Page A-354
50 (1.97)					
60 (2.36)	SH Geared	TH Geared	PS, PL Geared	PN Geared	Harmonic Geared
					
	Encoder Page A-338	Encoder Page A-343	Encoder Page A-345, A-350	Page A-353	Encoder Page A-355
90 (3.54)	SH Geared	TH Geared	PS Geared	PN Geared	Harmonic Geared
					
	Page A-340	Encoder Page A-343	Encoder Page A-345	Page A-353	Encoder Page A-355

Introduction

AC Input Motor & Driver
AR 0.36° / Geared
AS 0.72° / Geared

RK 0.9°/1.8°

UMK

DC Input Motor & Driver
AR 0.36° / Geared

ASX 0.36° / Geared

CRK 0.36°/0.72° / Geared

CMK 0.9°/1.8° / Geared

RBK 1.8° / Geared

PK 0.36°

PK 0.72°

PK 0.9°

PK/PV 1.8°

PK Geared

Controllers
SCX10
EMP400
/SG80301

Accessories

System Configuration

These accessories enable step angle 0.9°/1.8° **PK Series** products to be used for various operations.

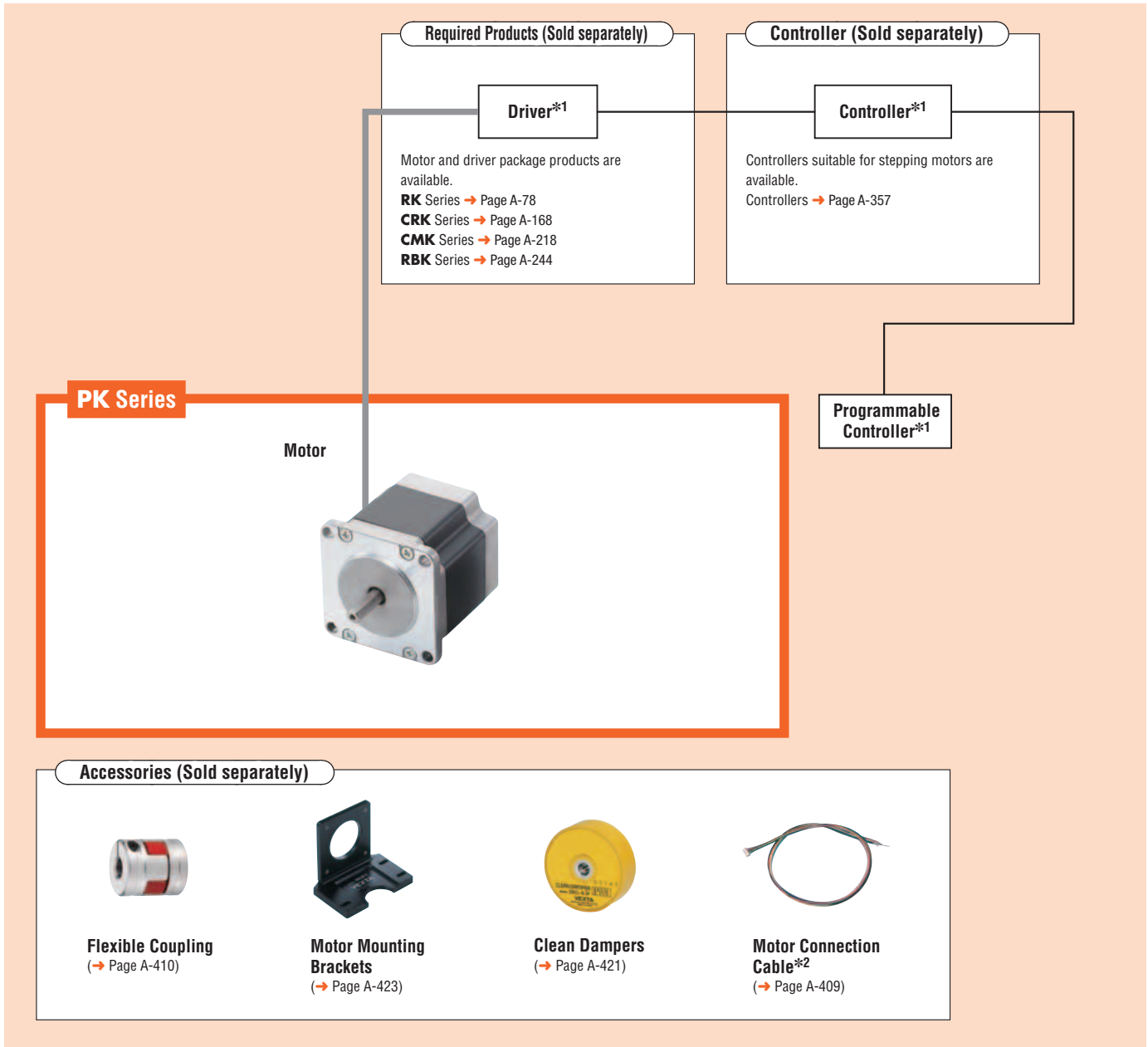

● Example of System Configuration

2-Phase PK Series	Sold Separately		
	Motors Mounting Bracket	Flexible Coupling	Clean Damper
PK264-01B	PAL2P-2	MC20F0408	D6CL-6.3F

● The system configuration shown above is an example. Other combinations are available.

*1 Not supplied

*2 A motor connection cable (0.6 m) is included with products that have product names ending in "L".

Motor and Driver Packages

To achieve maximum performance, motors with dedicated drivers are also available.

0.36°/0.72° Stepping Motor and Driver Package



AC Input
RK Series
→ Page A-78

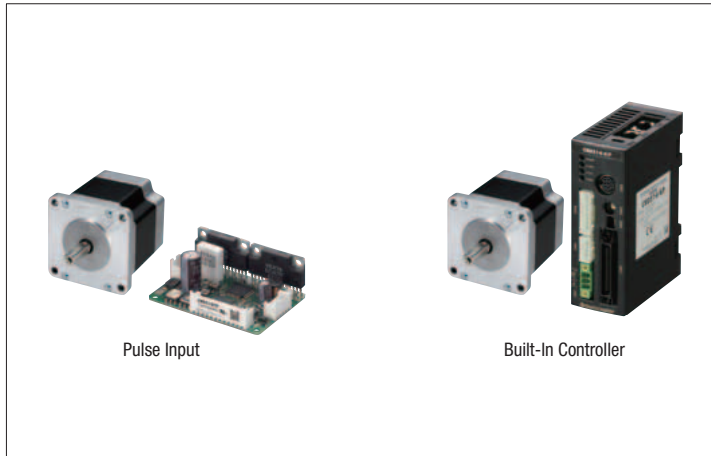

Pulse Input

Built-In Controller

DC Input
CRK Series
→ Page A-168

0.9°/1.8° Stepping Motor and Driver Package

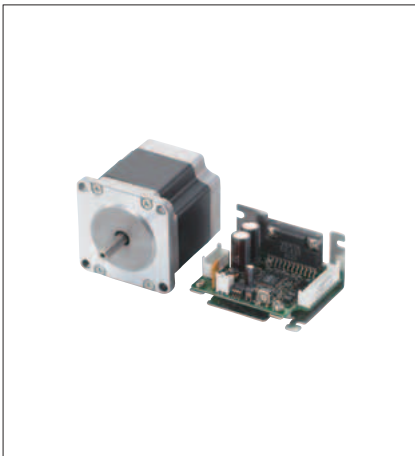

DC Input
CMK Series
→ Page A-218



DC Input
RBK Series
→ Page A-244

Introduction
AC Input Motor & Driver
0.36° / Geared / Geared
AR / AS
0.72° / Geared
RK
0.9°/1.8°
UMK
DC Input Motor & Driver
0.36° / Geared / Geared
AR / ASX
0.36° / Geared / Geared
CRK
0.9°/1.8° / Geared
CMK
1.8° / Geared
RBK
Motor Only
0.36°
PK
0.72°
PK
0.9°
PK
1.8°
PK/PV
Geared
PK
Controllers
SCX10 / EMP400 / SG8030J
Accessories

Product Number

PK5 indicates the step angle 0.36°/0.72° **PK** Series stepping motors.

PK2 indicates the step angle 0.9°/1.8° **PK** Series stepping motors.

PV2 indicates the step angle 1.8° **PV** Series stepping motors.

Step Angle 0.36°/0.72° High-Torque Type

PK 5 2 3 P M A

① ② ③ ④ ⑤

Step Angle 0.72° Standard Type

◇ Motor Frame Size 42 mm (1.65 in.), 60 mm (2.36 in.)

PK 5 4 3 NAW

① ② ③

◇ Motor Frame Size 85 mm (3.35 in.)

PK 5 9 6 BE

① ② ③

Step Angle 0.72° Standard Type Terminal Box

PK 5 9 6 A T

① ② ③ ④

Geared Type

◇ Motor Frame Size 20 mm (0.79 in.), 28 mm (1.10 in.)

PK 5 2 3 □ P A - T 10

① ② ③ ④ ⑤ ⑥ ⑦

◇ Motor Frame Size 42 mm (1.65 in.), 60 mm (2.36 in.)

PK 5 4 4 BW - N 5

① ② ③ ④ ⑤

◇ Motor Frame Size 90 mm (3.54 in.)

PK 5 9 9 AE - PS 5

① ② ③ ④ ⑤

①	Motor Frame Size	1: 20 mm (0.79 in.) 2: 28 mm (1.10 in.) 4: 42 mm (1.65 in.) 6: 60 mm (2.36 in.)
②	Motor Case Length	
③	Motor Type	
④	Resolution	M: 0.36°/Step Blank: 0.72°/Step
⑤	Shaft Type	A: Single Shaft B: Double Shaft

①	Motor Frame Size	4: 42 mm (1.65 in.) 6: 60 mm (2.36 in.) 9: 85 mm (3.35 in.)
②	Motor Case Length	
③	Shaft Type	NAW: Single Shaft NBW: Double Shaft AE: Single Shaft BE: Double Shaft

①	Motor Frame Size	6: 60 mm (2.36 in.) 9: 85 mm (3.35 in.)
②	Motor Case Length	
③	Shaft Type	A: Single Shaft
④	Terminal Box	

①	Motor Frame Size	1: 20 mm (0.79 in.) 2: 28 mm (1.10 in.)
②	Motor Case Length	
③	Motor Specifications	H: High Speed Blank: Standard
④	Motor Type	
⑤	Shaft Type	A: Single Shaft B: Double Shaft
⑥	Gearhead Type	T: TH Geared Type PS: PS Geared Type N: PN Geared Type H: Harmonic Geared Type
⑦	Gear Ratio	

①	Motor Frame Size	4: 42 mm (1.65 in.) 6: 60 mm (2.36 in.) 9: 90 mm (3.54 in.)
②	Motor Case Length	
③	Shaft Type	AW: Single Shaft BW: Double Shaft AE: Single Shaft BE: Double Shaft
④	Gearhead Type	T: TH Geared Type PS: PS Geared Type N: PN Geared Type H: Harmonic Geared Type
⑤	Gear Ratio	

● Step Angle 0.36°/0.72° High-Torque Type with Encoder

PK 5 4 4 P M A - R 2 8 L

① ② ③ ④ ⑤ ⑥ ⑦ ⑧ ⑨

● Step Angle 0.72° Standard Type with Encoder

◇ Motor Frame Size 42 mm (1.65 in.), 60 mm (2.36 in.)

PK 5 4 3 NAW - R 2 7 L

① ② ③ ④ ⑤ ⑥ ⑦

◇ Motor Frame Size 90 mm (3.54 in.)

PK 5 9 9 AE - R 2 7

① ② ③ ④ ⑤ ⑥

● Geared Type with Encoder

◇ Motor Frame Size 42 mm (1.65 in.), 60 mm (2.36 in.)

PK 5 4 5 AW R 2 7 L T 30

① ② ③ ④ ⑤ ⑥ ⑦ ⑧ ⑨

◇ Motor Frame Size 90 mm (3.54 in.)

PK 5 9 9 AE R 2 7 PS 5

① ② ③ ④ ⑤ ⑥ ⑧ ⑨

①	Motor Frame Size	4: 42 mm (1.65 in.) 6: 60 mm (2.36 in.)
②	Motor Case Length	
③	Motor Type	
④	Resolution	M: 0.36°/Step Blank: 0.72°/Step
⑤	Shaft Type	A: Single Shaft
⑥	Encoder Version	
⑦	Encoder Output	1: 2-Channel A, B 2: 3-Channel A, B index
⑧	Encoder Resolution	7: 500 P/R 8: 1000 P/R
⑨	Encoder Type	Blank: TTL Type L: Differential Type

①	Motor Frame Size	4: 42 mm (1.65 in.) 6: 60 mm (2.36 in.) 9: 90 mm (3.54 in.)
②	Motor Case Length	
③	Shaft Type	NAW: Single Shaft
④	Encoder Version	
⑤	Encoder Output	1: 2-Channel A, B 2: 3-Channel A, B index
⑥	Encoder Resolution	7: 500 P/R
⑦	Encoder Type	Blank: TTL Type L: Differential Type

①	Motor Frame Size	4: 42 mm (1.65 in.) 6: 60 mm (2.36 in.) 9: 90 mm (3.54 in.)
②	Motor Case Length	
③	Shaft Type	AW: Single Shaft AE: Single Shaft
④	Encoder Version	
⑤	Encoder Output	2: 3-Channel A, B index
⑥	Encoder Resolution	7: 500 P/R
⑦	Encoder Type	Blank: TTL Type L: Differential Type
⑧	Gearhead Type	T: TH Geared Type PS: PS Geared Type N: PN Geared Type H: Harmonic Geared Type
⑨	Gear Ratio	

Introduction	
AC Input Motor & Driver	0.36°/Geared / 0.72°/Geared / 0.9°/1.8°
DC Input Motor & Driver	0.36°/Geared / 0.36°/0.72°/Geared / 0.9°/1.8°/Geared / 1.8°/Geared
Motor Only	0.36° / 0.72° / 0.9° / 1.8°
Controllers	SCX10 / EMP400 / SG8030J
Accessories	

● Step Angle 0.9°/1.8° Standard Type

PK 2 4 3 M - 0 1 B A
 ① ② ③ ④ ⑤ ⑥ ⑦

①	Motor Frame Size	4: 42 mm (1.65 in.) 5: 50 mm (1.97 in.) 6: 56.4 mm (2.22 in.) 8: 85 mm (3.35 in.)
②	Motor Case Length	
③	Motor Type	M: 0.9°/Step Blank: 1.8°/Step
④	Reference Number	
⑤	Winding Specification	
⑥	Shaft Type	A: Single Shaft B: Double Shaft
⑦	U.S.A. Version	

● Step Angle 1.8° High-Torque Type

PK 2 6 6 P A A
 ① ② ③ ④ ⑤

①	Motor Frame Size	2: 28 mm (1.10 in.) 3: 35 mm (1.38 in.) 4: 42 mm (1.65 in.) 6: 56.4 mm (2.22 in.)
②	Motor Case Length	
③	Motor Type	P: High-Torque Type
④	Shaft Type	A: Single Shaft B: Double Shaft
⑤	U.S.A. Version	

● Step Angle 1.8° High-Torque, High-Efficiency Type

PKE 2 4 3 A - L
 ① ② ③ ④

①	Motor Frame Size	4: 42 mm (1.65 in.)
②	Motor Case Length	
③	Shaft Type	A: Single Shaft B: Double Shaft
④	Connection Cable	

● Step Angle 1.8° Standard Type Terminal Box

PK 2 6 4 D A T
 ① ② ③ ④ ⑤

①	Motor Frame Size	6: 56.4 mm (2.22 in.) 9: 85 mm (3.35 in.)
②	Motor Case Length	
③	Motor Lead	D: 4 Leads E: 8 Leads
④	Shaft Type	A: Single Shaft
⑤	Terminal Box	

● Step Angle 1.8° PV Series

PV 2 6 6 - 0 2 B A
 ① ② ③ ④ ⑤ ⑥

①	Motor Frame Size	6: 60 mm (2.36 in.)
②	Motor Case Length	
③	Motor Lead	0: 6 Leads D: 4 Leads
④	Winding Specification	
⑤	Shaft Type	A: Single Shaft B: Double Shaft
⑥	U.S.A. Version	

● Geared Type

◇ SH Geared Type Motor Frame Size 28 mm (1.10 in.)

PK 2 2 3 P A - SG 10
 ① ② ③ ④ ⑤ ⑥

①	Motor Frame Size	2: 28 mm (1.10 in.)
②	Motor Case Length	
③	Motor Type	
④	Shaft Type	A: Single Shaft B: Double Shaft
⑤	Gearhead Type	SG: SH Geared Type
⑥	Gear Ratio	

◇ SH Geared Type Motor Frame Size 42 mm (1.65 in.),
60 mm (2.36 in.), 90 mm (3.54 in.)

PK 2 6 4 A 1 A - SG 10
 ① ② ③ ④ ⑤ ⑥ ⑦

①	Motor Frame Size	4: 42 mm (1.65 in.) 6: 60 mm (2.22 in.) 9: 90 mm (3.54 in.)
②	Motor Case Length	
③	Shaft Type	A: Single Shaft B: Double Shaft
④	Winding Specification	
⑤	U.S.A. Version	
⑥	Gearhead Type	SG: SH Geared Type
⑦	Gear Ratio	

◇ **PS/PL Geared Type**

PK 2 4 4 P D A - P 10

① ② ③ ④ ⑤ ⑥ ⑦

● **Step Angle 0.9° Standard Type/Step Angle 1.8° High-Torque Type with Encoder**

PK 2 4 3 M A A R 1 5

① ② ③ ④ ⑤ ⑥ ⑦ ⑧

● **Step Angle 1.8° Standard Type with Encoder**

PK 2 4 3 - 0 1 A A R 1 5

① ② ③ ④ ⑤ ⑥ ⑦ ⑧ ⑨

● **Geared Type with Encoder**

◇ **SH Geared Type Motor Frame Size 28 mm (1.10 in.)**

PK 2 2 3 P A R 1 5 S 10

① ② ③ ④ ⑤ ⑥ ⑦ ⑧ ⑨

◇ **SH Geared Type Motor Frame Size 42 mm (1.65 in.), 60 mm (2.36 in.), 90 mm (3.54 in.)**

PK 2 6 4 A 2 A R 1 5 S 10

① ② ③ ④ ⑤ ⑥ ⑦ ⑧ ⑨ ⑩

◇ **PS/PL Geared Type**

PK 2 4 4 P D A R 1 5 - P 10

① ② ③ ④ ⑤ ⑥ ⑦ ⑧ ⑨ ⑩

①	Motor Frame Size	2: 28 mm (1.10 in.) 4: 42 mm (1.65 in.) 6: 60 mm (2.22 in.)
②	Motor Case Length	
③	Motor Type	
④	Motor Lead	D: 4 Leads
⑤	Shaft Type	A: Single Shaft B: Double Shaft
⑥	Gearhead Type	PS: PS Geared Type P: PL Geared Type
⑦	Gear Ratio	

①	Motor Frame Size	2: 28 mm (1.10 in.) 3: 35 mm (1.38 in.) 4: 42 mm (1.65 in.) 6: 56.4 mm (2.22 in.)
②	Motor Case Length	
③	Motor Type	M: 0.9°/Step P: High-Torque Type
④	Shaft Type	A: Single Shaft
⑤	U.S.A. Version	
⑥	Encoder Version	
⑦	Encoder Output	1: 2-Channel A, B 2: 3-Channel A, B, Index
⑧	Encoder Resolution	5: 200 R/P 6: 400 R/P

①	Motor Frame Size	4: 42 mm (1.65 in.) 5: 50 mm (1.97 in.) 6: 56.4 mm (2.22 in.)
②	Motor Case Length	
③	Motor Type	
④	Winding Specification	
⑤	Shaft Type	A: Single Shaft
⑥	U.S.A. Version	
⑦	Encoder Version	
⑧	Encoder Output	1: 2-Channel A, B 2: 3-Channel A, B, Index
⑨	Encoder Resolution	5: 200 R/P 6: 400 R/P

①	Motor Frame Size	2: 28 mm (1.10 in.)
②	Motor Case Length	
③	Motor Type	
④	Shaft Type	A: Single Shaft
⑤	Encoder Version	
⑥	Encoder Output	1: 2-Channel A, B
⑦	Encoder Resolution	5: 200 R/P
⑧	Gearhead Type	S: SH Geared Type
⑨	Gear Ratio	

①	Motor Frame Size	4: 42 mm (1.65 in.) 6: 60 mm (2.26 in.)
②	Motor Case Length	
③	Shaft Type	A: Single Shaft
④	Winding Specification	
⑤	U.S.A. Version	
⑥	Encoder Version	
⑦	Encoder Output	1: 2-Channel A, B 2: 3-Channel A, B, Index
⑧	Encoder Resolution	5: 200 R/P 6: 400 R/P
⑨	Gearhead Type	S: SH Geared Type
⑩	Gear Ratio	

①	Motor Frame Size	2: 28 mm (1.10 in.) 4: 42 mm (1.65 in.) 6: 60 mm (2.22 in.)
②	Motor Case Length	
③	Motor Type	
④	Motor Lead	D: 4 Leads
⑤	Shaft Type	A: Single Shaft
⑥	Encoder Version	
⑦	Encoder Output	1: 2-Channel A, B 2: 3-Channel A, B, Index
⑧	Encoder Resolution	5: 200 R/P 6: 400 R/P
⑨	Gearhead Type	PS: PS Geared Type P: PL Geared Type
⑩	Gear Ratio	

Introduction	
AC Input Motor & Driver	0.36° / Geared / Geared AS AS
DC Input Motor & Driver	0.36° / Geared / Geared ASX ASX
Motor Only	0.36° / Geared / Geared CRK CRK
	0.9° / 1.8° / Geared CMK CMK
	1.8° / Geared RBK RBK
	0.36° / Geared PK PK
	0.72° / Geared PK PK
	0.9° / Geared PK PK
	1.8° / Geared PK/PV PK/PV
Controllers	SCX10 / EMP400 / SG8030J
Accessories	

Product Line

● Step Angle: 0.36°/Step, PK Series

◇ High-Torque Type

Model (Single Shaft)	Model (Double Shaft)
PK523PMA	PK523PMB
PK524PMA	PK524PMB
PK525PMA	PK525PMB
PK544PMA	PK544PMB
PK546PMA	PK546PMB
PK564PMA	PK564PMB
PK566PMA	PK566PMB
PK569PMA	PK569PMB

● Step Angle: 0.72°/Step, PK Series

◇ High-Torque Type

Model (Single Shaft)	Model (Double Shaft)
PK513PA	PK513PB
PK523PA	PK523PB
PK525PA	PK525PB
PK544PA	PK544PB
PK546PA	PK546PB

◇ Standard Type

Model (Single Shaft)	Model (Double Shaft)
PK543NAW	PK543NBW
PK544NAW	PK544NBW
PK545NAW	PK545NBW
PK564NAW	PK564NBW
PK566NAW	PK566NBW
PK569NAW	PK569NBW
PK596AE	PK596BE
PK599AE	PK599BE
PK5913AE	PK5913BE

◇ Standard Type Terminal Box

Model (Single Shaft)
PK564AT
PK566AT
PK569AT
PK596AT
PK599AT
PK5913AT

The following items are included in each product.

Motor, Parallel Key*

*Only for the products with a key slot on the output shaft

◇ High-Torque Type with Encoder

Model (TTL Type Encoder)	Model (Differential Type Encoder)
—	—
—	—
—	—
PK544PMA-R <input type="checkbox"/>	PK544PMA-R28L
PK546PMA-R <input type="checkbox"/>	PK546PMA-R28L
PK564PMA-R <input type="checkbox"/>	PK564PMA-R28L
PK566PMA-R <input type="checkbox"/>	PK566PMA-R28L
PK569PMA-R <input type="checkbox"/>	PK569PMA-R28L

◇ High-Torque Type with Encoder

Model (TTL Type Encoder)	Model (Differential Type Encoder)
—	—
—	—
—	—
PK544PA-R <input type="checkbox"/>	PK544PA-R27L
PK546PA-R <input type="checkbox"/>	PK546PA-R27L

◇ Standard Type with Encoder

Model (TTL Type Encoder)	Model (Differential Type Encoder)
PK543NAW-R <input type="checkbox"/>	PK543NAW-R27L
PK544NAW-R <input type="checkbox"/>	PK544NAW-R27L
PK545NAW-R <input type="checkbox"/>	PK545NAW-R27L
PK564NAW-R <input type="checkbox"/>	PK564NAW-R27L
PK566NAW-R <input type="checkbox"/>	PK566NAW-R27L
PK569NAW-R <input type="checkbox"/>	PK569NAW-R27L
PK596AE-R <input type="checkbox"/>	—
PK599AE-R <input type="checkbox"/>	—
PK5913AE-R <input type="checkbox"/>	—

● Enter the encoder code (**17**, **18**, **27** or **28**) in the box () within the model name.

● Step Angle: 0.9°/Step, **PK Series**

◇ Standard Type

Model (Single Shaft)	Model (Double Shaft)
PK243M-01AA	PK243M-01BA
PK243M-02AA	PK243M-02BA
PK243M-03AA	PK243M-03BA
PK244M-01AA	PK244M-01BA
PK244M-02AA	PK244M-02BA
PK244M-03AA	PK244M-03BA
PK245M-01AA	PK245M-01BA
PK245M-02AA	PK245M-02BA
PK245M-03AA	PK245M-03BA
PK264M-01A	PK264M-01B
PK264M-02A	PK264M-02B
PK264M-03A	PK264M-03B
PK264M-E2.0A	PK264M-E2.0B
PK266M-01A	PK266M-01B
PK266M-02A	PK266M-02B
PK266M-03A	PK266M-03B
PK266M-E2.0A	PK266M-E2.0B
PK268M-01A	PK268M-01B
PK268M-02A	PK268M-02B
PK268M-03A	PK268M-03B
PK268M-E2.0A	PK268M-E2.0B

● Step Angle: 1.8°/Step, **PK Series**

◇ High-Torque · High Efficiency Type

Model (Single Shaft)	Model (Double Shaft)
PKE243DA-L	PKE243DB-L
PKE243A-L	PKE243B-L
PKE244DA-L	PKE244DB-L
PKE244A-L	PKE244B-L
PKE245DA-L	PKE245DB-L
PKE245A-L	PKE245B-L

◇ High-Torque Type

Model (Single Shaft)	Model (Double Shaft)
PK213PDA	PK213PDB
PK213PA	PK213PB
PK214PDA	PK214PDB
PK214PA	PK214PB
PK223PA	PK223PB
PK224PA	PK224PB
PK225PA	PK225PB
PK233PA	PK233PB
PK235PA	PK235PB
PK244PA	PK244PB
PK246PA	PK246PB
PK264PAA	PK264PBA
PK266PAA	PK266PBA
PK268PAA	PK268PBA

◇ Standard Type with Encoder

Model (TTL Type Encoder)
PK243MAAR <input type="checkbox"/>
-
-
PK244MAAR <input type="checkbox"/>
-
-
PK245MAAR <input type="checkbox"/>
-
-
PK264MAR <input type="checkbox"/>
-
-
PK266MAR <input type="checkbox"/>
-
-
PK268MAR <input type="checkbox"/>
-
-

◇ High-Torque Type with Encoder

Model (TTL Type Encoder)
-
-
-
-
PK223PAR15
PK224PAR15
PK225PAR15
PK233PAR <input type="checkbox"/>
PK235PAR <input type="checkbox"/>
PK244PAR <input type="checkbox"/>
PK246PAR <input type="checkbox"/>
PK264PAAR <input type="checkbox"/>
PK266PAAR <input type="checkbox"/>
PK268PAAR <input type="checkbox"/>

● Enter the encoder code (**15**, **16**, **25** or **26**) in the box () within the model name.

Introduction
AR ^{DSTEP}
0.36° / Geared
AS ^{DSTEP}
AC Input Motor & Driver
RK
0.72° / Geared
UMK
0.9°/1.8°
AR ^{DSTEP}
0.36° / Geared
ASX ^{DSTEP}
0.36° / Geared
CRK
0.36°/0.72° / Geared
CMK
0.9°/1.8° / Geared
RBK
1.8° / Geared
PK
0.36°
PK
0.72°
PK
0.9°
PK/PV
1.8°
Geared
PK
Controllers
SCX10
EMP400
/SG8030J
Accessories

◇ Standard Type

Model (Single Shaft)	Model (Double Shaft)
PK243-01AA	PK243-01BA
PK243-02AA	PK243-02BA
PK243-03AA	PK243-03BA
PK244-01AA	PK244-01BA
PK244-02AA	PK244-02BA
PK244-03AA	PK244-03BA
PK244-04AA	PK244-04BA
PK245-01AA	PK245-01BA
PK245-02AA	PK245-02BA
PK245-03AA	PK245-03BA
PK256-02A	PK256-02B
PK258-02A	PK258-02B
PK264-01A	PK264-01B
PK264-02A	PK264-02B
PK264-03A	PK264-03B
PK264-E2.0A	PK264-E2.0B
PK266-01A	PK266-01B
PK266-02A	PK266-02B
PK266-03A	PK266-03B
PK266-E2.0A	PK266-E2.0B
PK268-01A	PK268-01B
PK268-02A	PK268-02B
PK268-03A	PK268-03B
PK268-E2.0A	PK268-E2.0B
PK296-01AA	PK296-01BA
PK296-02AA	PK296-02BA
PK296-03AA	PK296-03BA
PK296-F4.5A	PK296-F4.5B
PK299-01AA	PK299-01BA
PK299-02AA	PK299-02BA
PK299-03AA	PK299-03BA
PK299-F4.5A	PK299-F4.5B
PK2913-01AA	PK2913-01BA
PK2913-02AA	PK2913-02BA
PK2913-F4.0A	PK2913-F4.0B

◇ Standard Type with Encoder

Model (TTL Type Encoder)
PK243-01AAR <input type="checkbox"/>
-
-
PK244-01AAR <input type="checkbox"/>
-
-
-
PK245-01AAR <input type="checkbox"/>
-
-
PK256-02AR <input type="checkbox"/>
PK258-02AR <input type="checkbox"/>
-
PK264-02AR <input type="checkbox"/>
-
-
-
PK266-02AR <input type="checkbox"/>
-
-
-
PK268-02AR <input type="checkbox"/>
-
-

◇ Standard Type Terminal Box

Model (Single Shaft)
PK264DAT
PK266DAT
PK268DAT
PK296EAT
PK299EAT
PK2913EAT

● Step Angle: 1.8°/Step, **PV Series**

◇ High Inertia Capability

Model (Single Shaft)	Model (Double Shaft)
PV264-D2.8AA	PV264-D2.8BA
PV264-02AA	PV264-02BA
PV266-D2.8AA	PV266-D2.8BA
PV266-02AA	PV266-02BA
PV267-D2.8AA	PV267-D2.8BA
PV267-02AA	PV267-02BA
PV269-D2.8AA	PV269-D2.8BA
PV269-02AA	PV269-02BA

● Enter the encoder code (**15**, **16**, **25** or **26**) in the box () within the model name.

● Geared, PK Series

◇ SH Geared Type

Model (Single Shaft)	Model (Double Shaft)
PK223PA-SG7.2	PK223PB-SG7.2
PK223PA-SG9	PK223PB-SG9
PK223PA-SG10	PK223PB-SG10
PK223PA-SG18	PK223PB-SG18
PK223PA-SG36	PK223PB-SG36
PK243A1A-SG3.6	PK243B1A-SG3.6
PK243A1A-SG7.2	PK243B1A-SG7.2
PK243A1A-SG9	PK243B1A-SG9
PK243A1A-SG10	PK243B1A-SG10
PK243A1A-SG18	PK243B1A-SG18
PK243A1A-SG36	PK243B1A-SG36
PK243A2A-SG3.6	PK243B2A-SG3.6
PK243A2A-SG7.2	PK243B2A-SG7.2
PK243A2A-SG9	PK243B2A-SG9
PK243A2A-SG10	PK243B2A-SG10
PK243A2A-SG18	PK243B2A-SG18
PK243A2A-SG36	PK243B2A-SG36
PK264A1A-SG3.6	PK264B1A-SG3.6
PK264A1A-SG7.2	PK264B1A-SG7.2
PK264A1A-SG9	PK264B1A-SG9
PK264A1A-SG10	PK264B1A-SG10
PK264A1A-SG18	PK264B1A-SG18
PK264A1A-SG36	PK264B1A-SG36
PK264A2A-SG3.6	PK264B2A-SG3.6
PK264A2A-SG7.2	PK264B2A-SG7.2
PK264A2A-SG9	PK264B2A-SG9
PK264A2A-SG10	PK264B2A-SG10
PK264A2A-SG18	PK264B2A-SG18
PK264A2A-SG36	PK264B2A-SG36
PK296A1A-SG3.6	PK296B1A-SG3.6
PK296A1A-SG7.2	PK296B1A-SG7.2
PK296A1A-SG9	PK296B1A-SG9
PK296A1A-SG10	PK296B1A-SG10
PK296A1A-SG18	PK296B1A-SG18
PK296A1A-SG36	PK296B1A-SG36
PK296A2A-SG3.6	PK296B2A-SG3.6
PK296A2A-SG7.2	PK296B2A-SG7.2
PK296A2A-SG9	PK296B2A-SG9
PK296A2A-SG10	PK296B2A-SG10
PK296A2A-SG18	PK296B2A-SG18
PK296A2A-SG36	PK296B2A-SG36

◇ SH Geared Type with Encoder

Model (TTL Type Encoder)
PK223PAR15S7.2
PK223PAR15S9
PK223PAR15S10
PK223PAR15S18
PK223PAR15S36
PK243A1AR <input type="checkbox"/> S3.6
PK243A1AR <input type="checkbox"/> S7.2
PK243A1AR <input type="checkbox"/> S9
PK243A1AR <input type="checkbox"/> S10
PK243A1AR <input type="checkbox"/> S18
PK243A1AR <input type="checkbox"/> S36
—
—
—
—
—
—
—
—
—
—
—
PK264A2AR <input type="checkbox"/> S3.6
PK264A2AR <input type="checkbox"/> S7.2
PK264A2AR <input type="checkbox"/> S9
PK264A2AR <input type="checkbox"/> S10
PK264A2AR <input type="checkbox"/> S18
PK264A2AR <input type="checkbox"/> S36

● Enter the encoder code (15, 16, 25 or 26) in the box () within the model name.

Introduction
AR ^{DSTEP} / Geared
AS ^{DSTEP} / Geared
RK / Geared
UMK
0.9°/1.8°
AR ^{DSTEP} / Geared
ASX ^{DSTEP} / Geared
CRK / Geared
CMK / Geared
RBK / Geared
PK
PK
PK
PK/PV
Geared PK
Controllers SCX10 / EMP400 / SG8030J
Accessories

◇TH Geared Type

Model (Single Shaft)	Model (Double Shaft)
PK523PA-T7.2	PK523PB-T7.2
PK523PA-T10	PK523PB-T10
PK523PA-T20	PK523PB-T20
PK523PA-T30	PK523PB-T30
PK543AW-T3.6	PK543BW-T3.6
PK543AW-T7.2	PK543BW-T7.2
PK543AW-T10	PK543BW-T10
PK543AW-T20	PK543BW-T20
PK543AW-T30	PK543BW-T30
PK564AW-T3.6	PK564BW-T3.6
PK564AW-T7.2	PK564BW-T7.2
PK564AW-T10	PK564BW-T10
PK564AW-T20	PK564BW-T20
PK564AW-T30	PK564BW-T30
PK596AE-T3.6	PK596BE-T3.6
PK596AE-T7.2	PK596BE-T7.2
PK596AE1-T10	PK596BE1-T10
PK596AE1-T20	PK596BE1-T20
PK596AE1-T30	PK596BE1-T30

◇PS Geared Type

Model (Single Shaft)	Model (Double Shaft)
PK523PA-PS5	PK523PB-PS5
PK523PA-PS7	PK523PB-PS7
PK523PA-PS10	PK523PB-PS10
PK545AW-PS5	PK545BW-PS5
PK545AW-PS7	PK545BW-PS7
PK545AW-PS10	PK545BW-PS10
PK543AW-PS25	PK543BW-PS25
PK543AW-PS36	PK543BW-PS36
PK543AW-PS50	PK543BW-PS50
PK566AW-PS5	PK566BW-PS5
PK566AW-PS7	PK566BW-PS7
PK566AW-PS10	PK566BW-PS10
PK564AW-PS25	PK564BW-PS25
PK564AW-PS36	PK564BW-PS36
PK564AW-PS50	PK564BW-PS50
PK599AE-PS5	PK599BE-PS5
PK599AE-PS7	PK599BE-PS7
PK599AE-PS10	PK599BE-PS10
PK596AE-PS25	PK596BE-PS25
PK596AE-PS36	PK596BE-PS36
PK596AE-PS50	PK596BE-PS50
PK223PDA-PS5	PK223PDB-PS5
PK223PDA-PS10	PK223PDB-PS10

◇PL Geared Type

Model (Single Shaft)	Model (Double Shaft)
PK244PDA-P5	PK244PDB-P5
PK244PDA-P10	PK244PDB-P10
PK244PDA-P36	PK244PDB-P36
PK266PDA-P5	PK266PDB-P5
PK266PDA-P10	PK266PDB-P10
PK264PDA-P36	PK264PDB-P36

◇TH Geared Type with Encoder

Model (TTL Type Encoder)	Model (Differential Type Encoder)
—	—
—	—
—	—
—	—
PK543AWR27T3.6	PK543AWR27LT3.6
PK543AWR27T7.2	PK543AWR27LT7.2
PK543AWR27T10	PK543AWR27LT10
PK543AWR27T20	PK543AWR27LT20
PK543AWR27T30	PK543AWR27LT30
PK564AWR27T3.6	PK564AWR27LT3.6
PK564AWR27T7.2	PK564AWR27LT7.2
PK564AWR27T10	PK564AWR27LT10
PK564AWR27T20	PK564AWR27LT20
PK564AWR27T30	PK564AWR27LT30
PK596AER27T3.6	—
PK596AER27T7.2	—
PK596AE1R27T10	—
PK596AE1R27T20	—
PK596AE1R27T30	—

◇PS Geared Type with Encoder

Model (TTL Type Encoder)	Model (Differential Type Encoder)
—	—
—	—
—	—
PK545AWR27PS5	PK545AWR27LPS5
PK545AWR27PS7	PK545AWR27LPS7
PK545AWR27PS10	PK545AWR27LPS10
PK543AWR27PS25	PK543AWR27LPS25
PK543AWR27PS36	PK543AWR27LPS36
PK543AWR27PS50	PK543AWR27LPS50
PK566AWR27PS5	PK566AWR27LPS5
PK566AWR27PS7	PK566AWR27LPS7
PK566AWR27PS10	PK566AWR27LPS10
PK564AWR27PS25	PK564AWR27LPS25
PK564AWR27PS36	PK564AWR27LPS36
PK564AWR27PS50	PK564AWR27LPS50
PK599AER27PS5	—
PK599AER27PS7	—
PK599AER27PS10	—
PK596AER27PS25	—
PK596AER27PS36	—
PK596AER27PS50	—

◇PL Geared Type with Encoder

Model (TTL Type Encoder)
PK244PDAR <input type="checkbox"/> -P5
PK244PDAR <input type="checkbox"/> -P10
PK244PDAR <input type="checkbox"/> -P36
PK266PDAR <input type="checkbox"/> -P5
PK266PDAR <input type="checkbox"/> -P10
PK264PDAR <input type="checkbox"/> -P36

● Enter the encoder code (15, 16, 25 or 26) in the box (□) within the model name.

◇ PN Geared Type

Model (Single Shaft)	Model (Double Shaft)
PK523PA-N5	PK523PB-N5
PK523PA-N7.2	PK523PB-N7.2
PK523PA-N10	PK523PB-N10
PK544AW-N5	PK544BW-N5
PK544AW-N7.2	PK544BW-N7.2
PK544AW-N10	PK544BW-N10
PK566AW-N5	PK566BW-N5
PK566AW-N7.2	PK566BW-N7.2
PK566AW-N10	PK566BW-N10
PK564AW-N25	PK564BW-N25
PK564AW-N36	PK564BW-N36
PK564AW-N50	PK564BW-N50
PK599AE-N5	PK599BE-N5
PK599AE-N7.2	PK599BE-N7.2
PK599AE-N10	PK599BE-N10
PK596AE-N25	PK596BE-N25
PK596AE-N36	PK596BE-N36
PK596AE-N50	PK596BE-N50

◇ Harmonic Geared Type

Model (Single Shaft)	Model (Double Shaft)
PK513PA-H50S	PK513PB-H50S
PK513PA-H100S	PK513PB-H100S
PK523HPA-H50S	PK523HPB-H50S
PK523HPA-H100S	PK523HPB-H100S
PK543AW-H50S	PK543BW-H50S
PK543AW-H100S	PK543BW-H100S
PK564AW-H50S	PK564BW-H50S
PK564AW-H100S	PK564BW-H100S
PK596AE1-H50	PK596BE1-H50
PK596AE1-H100	PK596BE1-H100

◇ Harmonic Geared Type with Encoder

Model (TTL Type Encoder)	Model (Differential Type Encoder)
-	-
-	-
-	-
-	-
PK543AWR27H50	PK543AWR27LH50
PK543AWR27H100	PK543AWR27LH100
PK564AWR27H50	PK564AWR27LH50
PK564AWR27H100	PK564AWR27LH100
PK596AE1R27H50	-
PK596AE1R27H100	-

Introduction	
AR	0.36° / Geared
AS	0.36° / Geared
RK	0.72° / Geared
UMK	0.9°/1.8°
AR	0.36° / Geared
ASX	0.36° / Geared
CRK	0.36°/0.72° / Geared
CMK	0.9°/1.8° / Geared
RBK	1.8° / Geared
PK	0.36°
PK	0.72°
PK	0.9°
PK/PV	1.8°
PK	Geared
SCX10 / EMP400 / SG8030J	Controllers
	Accessories

Wirings and Connections

- Step Angle 0.36°/0.72° Standard Type, Step Angle 0.72° High-Torque Type, Geared Type

Inner Wiring Diagram for Motor

Connection Type: New Pentagon (Bipolar)

For more details on the New Pentagon (Bipolar), please visit www.orientalmotor.com

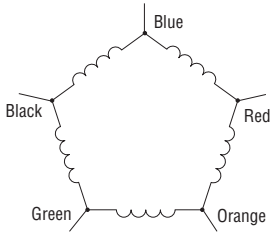

Step Angle 0.72° Standard Type Terminal Box PK564AT, PK566AT, PK569AT

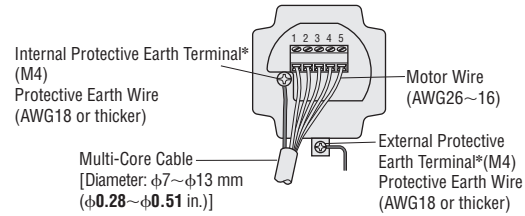

*Use either the internal or external protective earth terminal for grounding.

PK596AT, PK599AT, PK5913AT

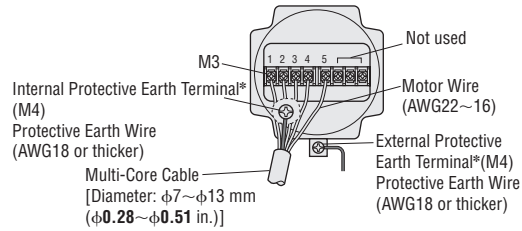

- Step Angle 0.9°/1.8° Standard Type, Step Angle 1.8° High-Torque Type, Step Angle 1.8° PV Series, Geared Type

Inner Wiring Diagram for Motor

4-Lead Motor

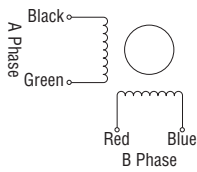

5-Lead Motor

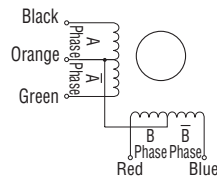

6-Lead Motor

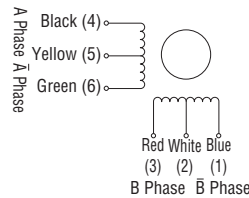

8-Lead Motor

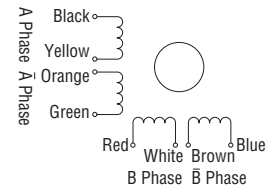

Wiring Connection Diagram

4 Leads Bipolar Connection

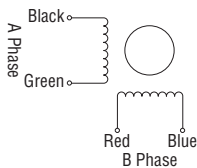

5 Leads Unipolar Connection

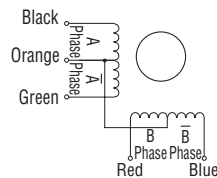

6 Leads Unipolar Connection

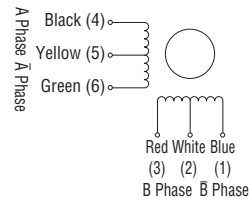

6 Leads Bipolar (Series) Connection

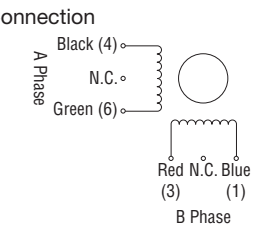

8 Leads Unipolar Connection

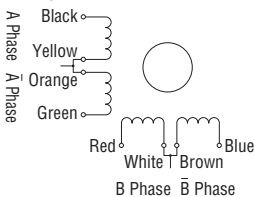

8 Leads Bipolar (Series) Connection

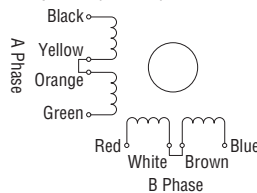

8 Leads Bipolar (Parallel) Connection

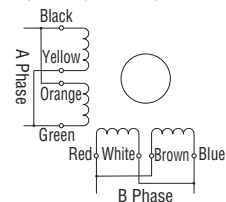

- The numbers inside the parentheses indicate the connector pin No. of the high-torque type motor.
- N.C.: No Connection

● Step Angle 1.8° Standard Type Terminal Box

◇ Motor Connections

● PK26 □ DAT

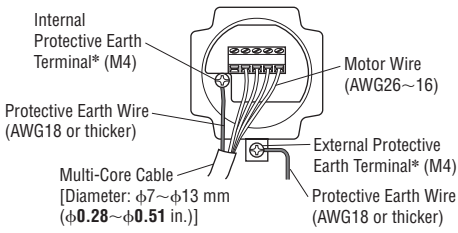

*Use either the internal or external protective earth terminal for grounding.

● PK29 □ EAT

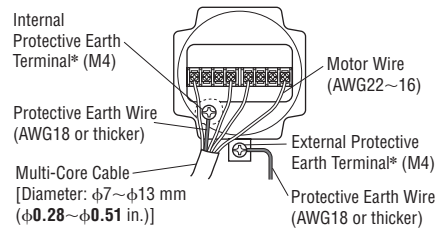

*Use either the internal or external protective earth terminal for grounding.

◇ Wiring Connection Diagram

● PK26 □ DAT

Bipolar

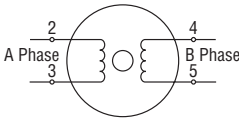

Connect motor lead wires to the terminals 2 to 5.

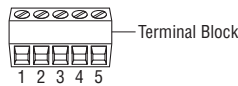

● PK29 □ EAT

Bipolar (Series)

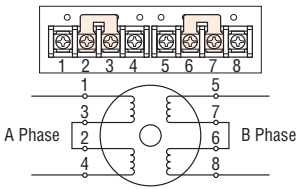

Bipolar (Parallel)

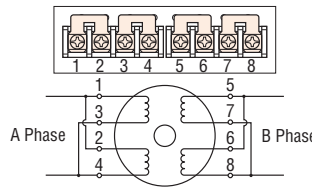

Unipolar

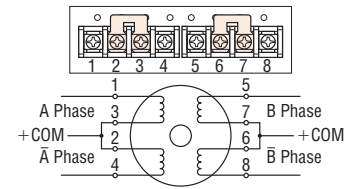

■ Notes on the Speed – Torque Characteristics Diagram

The speed – torque characteristics featured in this catalog are measured with a constant-current driver or a constant-voltage driver. The actual characteristics will vary depending on the driver used. Please use these diagrams only for reference purposes when selecting a motor. You must also conduct a thorough evaluation with the actual driver to be used.

Introduction	
AR	0.36° / Geared
AS	0.36° / Geared
RK	0.72° / Geared
UMK	0.9° / 1.8°
AR	0.36° / Geared
ASX	0.36° / Geared
CRK	0.36° / 0.72° / Geared
CMK	0.9° / 1.8° / Geared
RBK	1.8° / Geared
PK	0.36°
PK	0.72°
PK	0.9°
PK/PV	1.8°
PK	Geared
SCX10 / EMP400 / SG8030J	Controllers
	Accessories

Step Angle 0.36°

Motor Frame Size 28 mm (1.10 in.), 42 mm (1.65 in.), 60 mm (2.36 in.)

PK Series High-Torque Type



Specifications (RoHS)



Motor Frame Size mm (in.)	Model • Single Shaft/Double Shaft • with TTL Type Encoder • with Differential Type Encoder	Connection Type	Maximum Holding Torque		Rated Current A/phase	Rotor Inertia J		Motor Lead Wires (Pins)	Corresponding Motor & Driver Package CRK Series (Pulse/Built-In Program)
			N-m	oz-in		kg-m ²	oz-in ²		
28 (1.10)	PK523PM□	New Pentagon (Bipolar)	0.042	5.9	0.35	9×10 ⁻⁷	0.049	5	CRK523PM□P CRK523PM□KP
	PK524PM□		0.061	8.6		13×10 ⁻⁷	0.071		CRK524PM□P CRK524PM□KP
	PK525PM□		0.09	12.7		19×10 ⁻⁷	0.104		CRK525PM□P CRK525PM□KP
42 (1.65)	PK544PM□ PK544PMA-R□ PK544PMA-R28L		0.24	34	0.75	60×10 ⁻⁷	0.33		CRK544PM□P CRK544PM□KP CRK544PMAP-R28 CRK544PMRKP
	PK546PM□ PK546PMA-R□ PK546PMA-R28L		0.42	59		121×10 ⁻⁷	0.66		CRK546PM□P CRK546PM□KP CRK546PMAP-R28 CRK546PMRKP
	PK564PM□ PK564PMA-R□ PK564PMA-R28L		0.78	110	310×10 ⁻⁷	1.7	CRK564PM□P CRK564PM□KP CRK564PMAP-R28 CRK564PMRKP		
60 (2.36)	PK566PM□ PK566PMA-R□ PK566PMA-R28L		1.3	184	1.4	480×10 ⁻⁷	2.7		CRK566PM□P CRK566PM□KP CRK566PMAP-R28 CRK566PMRKP
	PK569PM□ PK569PMA-R□ PK569PMA-R28L		2.3	320	970×10 ⁻⁷	5.3	CRK569PM□P CRK569PM□KP CRK569PMAP-R28 CRK569PMRKP		

- Wirings and connections → Page A-288
- Encoder specifications → Page A-17
- See the page for the corresponding motor and driver package for speed-torque characteristics and dimensions.
- The dimensions of a motor with an encoder can be found on page A-20.
- The motor connection cable is available as an accessory.
- Enter the encoder code (17, 18, 27, or 28) in the box (□) within the model name.
- Enter A (single shaft) or B (double shaft) in the box (□) within the model name.
- Product Number Code → Page A-278
- *1 Adopted for motor frame size 28 mm (1.10 in.) and 60 mm (2.36 in.) products.
- *2 Adopted for motor frame size 42 mm (1.65 in.) products.
- *3 CE Marking is applied to a corresponding motor and driver package product.

Introduction of Stepping Motor and Driver Packages

Stepping motor and driver packages are available. Packages are outfitted with drivers specifically designed to obtain the motor's maximum performance.

DC Input Motor and Driver Package

CRK Series → Page A-168

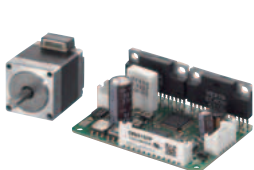

Pulse Input



Built-In Controller

Step Angle 0.72°

Motor Frame Size 20 mm (0.79 in.), 28 mm (1.10 in.), 42 mm (1.65 in.)

PK Series High-Torque Type



Specifications (RoHS)



Motor Frame Size mm (in.)	Model • Single Shaft/Double Shaft • with TTL Type Encoder • with Differential Type Encoder	Connection Type	Maximum Holding Torque		Rated Current A/phase	Rotor Inertia J		Motor Lead Wires (Pins)	Corresponding Motor & Driver Package CRK Series (Pulse/Built-In Program)
			N-m	oz-in		kg·m ²	oz-in ²		
20 (0.79)	PK513P □	New Pentagon (Bipolar)	0.0231	3.2	0.35	1.6×10 ⁻⁷	0.0088	5	CRK513P □P CRK513P □KP
28 (1.10)	PK523P □		0.048	6.8		9×10 ⁻⁷	0.049		CRK523P □P CRK523P □KP
	PK525P □		0.078	11		18×10 ⁻⁷	0.098		CRK525P □P CRK525P □KP
42 (1.65)	PK544P □ PK544PA-R □ PK544PA-R27L		0.24	34	0.75	57×10 ⁻⁷	0.31		CRK544P □P CRK544P □KP CRK544PAP-R27 CRK544PRKP
	PK546P □ PK546PA-R □ PK546PA-R27L		0.42	59		114×10 ⁻⁷	0.62		CRK546P □P CRK546P □KP CRK546PAP-R27 CRK546PRKP

- Wirings and connections → Page A-288
- Encoder specifications → Page A-17
- See the page for the corresponding motor and driver package for speed-torque characteristics and dimensions.
- The dimensions of a motor with an encoder can be found on page A-20.
- The motor connection cable is available as an accessory.
- Enter the encoder code (**17**, **18**, **27**, or **28**) in the box (□) within the model name. Enter **A** (single shaft) or **B** (double shaft) in the box (□) within the model name. Product Number Code → Page A-278
- *1 Adopted for motor frame size 28 mm (1.10 in.) and 60 mm (2.36 in.) products.
- *2 Adopted for motor frame size 42 mm (1.65 in.) products.
- *3 CE Marking is applied to a corresponding motor and driver package product.

Introduction of Stepping Motor and Driver Packages

Stepping motor and driver packages are available. Packages are outfitted with drivers specifically designed to obtain the motor's maximum performance.

DC Input

Motor and Driver Package

CRK Series → Page A-168

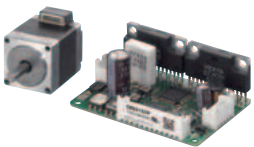

Pulse Input



Built-In Controller

Introduction
AR / GEARED / AS
0.36° / GEARED / AS
AC Input Motor & Driver
RK / GEARED
0.72° / GEARED
UMK
0.9°/1.8°
AR / GEARED / AS
0.36° / GEARED / AS
DC Input Motor & Driver
CRK / GEARED
0.36°/0.72° / GEARED
CMK
0.9°/1.8° / GEARED
RBK
1.8° / GEARED
PK
0.36°
PK
0.72°
PK
0.9°
PK
1.8°
PK/PV
GEARED
PK
Controllers
SCX10 / EMP400 / SG8030J
Accessories

Step Angle 0.72°

Motor Frame Size 42 mm (1.65 in.), 60 mm (2.36 in.), 85 mm (3.35 in.)
PK Series Standard Type



Specifications (RoHS)



Motor Frame Size mm (in.)	Model • Single Shaft/Double Shaft • with TTL Type Encoder • with Differential Type Encoder	Connection Type	Maximum Holding Torque		Rated Current A/phase	Rotor Inertia J		Motor Lead Wires (Pins)	Corresponding Motor & Driver Package RK Series CRK Series (Pulse/Built-In Program)		
			N-m	oz-in		kg-m ²	oz-in ²				
42 (1.65)	PK543N□W PK543NAW-R□ PK543NAW-R27L	New Pentagon (Bipolar)	0.13	18.4	0.75	35×10 ⁻⁷	0.191	5	CRK543□P CRK543□KP CRK543AP-R27 CRK543RKP		
	PK544N□W PK544NAW-R□ PK544NAW-R27L		0.18	25		54×10 ⁻⁷	0.3		CRK544□P CRK544□KP CRK544AP-R27 CRK544RKP		
	PK545N□W PK545NAW-R□ PK545NAW-R27L		0.24	34		68×10 ⁻⁷	0.37		CRK545□P CRK545□KP CRK545AP-R27 CRK545RKP		
60 (2.36)	PK564N□W PK564NAW-R□ PK564NAW-R27L		0.42	59	1.4	175×10 ⁻⁷	0.96		5	CRK564□P CRK564□KP CRK564AP-R27 CRK564RKP	
	PK566N□W PK566NAW-R□ PK566NAW-R27L		0.83	117		280×10 ⁻⁷	1.53			CRK566□P CRK566□KP CRK566AP-R27 CRK566RKP	
	PK569N□W PK569NAW-R□ PK569NAW-R27L		1.66	230		560×10 ⁻⁷	3.1			CRK569□P CRK569□KP CRK569AP-R27 CRK569RKP	
85 (3.35)	PK596□E PK596AE-R27		2.1	290	6.3	1400×10 ⁻⁷	7.7			5	RK596□E RK596AE-R27
	PK599□E PK599AE-R27		4.1	580		2700×10 ⁻⁷	14.8				RK599□E RK599AE-R27
	PK5913□E PK5913AE-R27		6.3	890		4000×10 ⁻⁷	22				RK5913□E RK5913AE-R27

- Wirings and connections → Page A-288
Encoder specifications → Page A-17
- See the page for the corresponding motor and driver package for speed-torque characteristics and dimensions.
- The dimensions of a motor with an encoder can be found on page A-20.
- Enter the **A** (single shaft) or **B** (double shaft) in the box (□) within the model name.
Enter the encoder code (**17**, **18**, **27**, or **28**) in the box (□) within the model name.
Enter the **A** (single-phase 100-115 VAC) or **C** (single-phase 200-230 VAC) in the box (□) within the model name.
Product Number Code → Page A-278
- *1 Adopted for motor frame size 28 mm (1.10 in.) and 60 mm (2.36 in.) products.
- *2 Adopted for motor frame size 42 mm (1.65 in.) products.
- *3 CE Marking is applied to a corresponding motor and driver package product.

Introduction of Stepping Motor and Driver Packages

Stepping motor and driver packages are available. Packages are outfitted with drivers specifically designed to obtain the motor's maximum performance.

AC Input
Motor and Driver Package
RK Series → Page A-78

DC Input
Motor and Driver Package
CRK Series → Page A-168

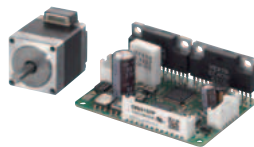

Pulse Input

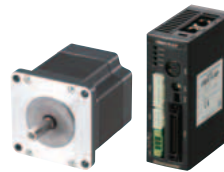

Built-In Controller

Step Angle 0.72°

Motor Frame Size 60 mm (2.36 in.), 85 mm (3.35 in.)

PK Series Standard Type Terminal Box



Specifications (RoHS)



Motor Frame Size mm (in.)	Model • Single Shaft	Connection Type	Maximum Holding Torque		Rated Current A/phase	Rotor Inertia J		Motor Lead Wires (Pins)	Corresponding Motor & Driver Package
			N·m	oz-in		kg·m ²	oz-in ²		RK Series
60 (2.36)	PK564AT	New Pentagon (Bipolar)	0.42	59	1.4	175×10 ⁻⁷	0.96	5	RK564A□T
	PK566AT		0.83	117		280×10 ⁻⁷	1.53		RK566A□T
	PK569AT		1.66	230		560×10 ⁻⁷	3.1		RK569A□T
85 (3.35)	PK596AT		2.1	290		1400×10 ⁻⁷	7.7		RK596A□T
	PK599AT		4.1	580		2700×10 ⁻⁷	14.8		RK599A□T
	PK5913AT		6.3	890		4000×10 ⁻⁷	22		RK5913A□T

- Wires and connections → Page A-288
- See the page for the corresponding motor and driver package for speed-torque characteristics and dimensions.
- Enter the **A** (single-phase 100-115 VAC) or **C** (single-phase 200-230 VAC) in the box (□) with in the model name.
- *CE Marking is applied to a corresponding motor and driver package product.

Introduction of Stepping Motor and Driver Packages

Stepping motor and driver packages are available. Packages are outfitted with drivers specifically designed to obtain the motor's maximum performance.

AC Input

Motor and Driver Package

RK Series → Page A-78



Introduction	AC Input Motor & Driver	DC Input Motor & Driver	Motor Only	Controllers	Accessories
AR DSTEP	0.36° / Geared AS DSTEP	0.36° / Geared AR DSTEP	0.36°	SCX10 EMP400 /SG8030J	
RK	0.72° / Geared	0.36°/0.72° / Geared CRK	0.72°		
UMK	0.9°/1.8°	0.9°/1.8° / Geared CMK	0.9°		
		1.8° / Geared RBK	1.8°		
		PK	PK		
		PK	PK/PV		
		PK	Geared PK		

Step Angle 0.9°

Motor Frame Size 42 mm (1.65 in.)

PK Series Standard Type



Specifications (RoHS)

Model	Connection Type	Holding Torque		Rated Current	Voltage	Resistance	Inductance	Rotor Inertia J		Lead Wires	Corresponding AC/DC-Input Motor & Driver Package
		N·m	oz·in					kg·m ²	oz·in ²		
PK243M-01AA PK243M-01BA PK243MAAR	Bipolar (Series)	0.2	28	0.67	5.6	8.4	15.2	35×10 ⁻⁷	0.191	6	UMK243M□A/ CMK243M□PA/ CMK243MAPA-R
	Unipolar	0.16	22	0.95	4	4.2	3.8				
PK243M-02AA PK243M-02BA	Bipolar (Series)	0.2	28	0.42	8.4	20	38.8	35×10 ⁻⁷	0.191	6	-
	Unipolar	0.16	22	0.6	6	10	9.7				
PK243M-03AA PK243M-03BA	Bipolar (Series)	0.2	28	0.22	17	77	136	35×10 ⁻⁷	0.191	6	-
	Unipolar	0.16	22	0.31	12	38.5	34				
PK244M-01AA PK244M-01BA PK244MAAR	Bipolar (Series)	0.31	44	0.85	5.6	6.6	17.2	54×10 ⁻⁷	0.3	6	UMK244M□A/ CMK244M□PA/ CMK244MAPA-R
	Unipolar	0.26	36	1.2	4	3.3	4.3				
PK244M-02AA PK244M-02BA	Bipolar (Series)	0.31	44	0.57	8.6	15	38.8	54×10 ⁻⁷	0.3	6	-
	Unipolar	0.26	36	0.8	6	7.5	9.7				
PK244M-03AA PK244M-03BA	Bipolar (Series)	0.31	44	0.28	17	60	152	54×10 ⁻⁷	0.3	6	-
	Unipolar	0.26	36	0.4	12	30	38				
PK245M-01AA PK245M-01BA PK245MAAR	Bipolar (Series)	0.38	53	0.85	5.6	6.6	15.6	68×10 ⁻⁷	0.37	6	UMK245M□A/ CMK245M□PA/ CMK245MAPA-R
	Unipolar	0.32	45	1.2	4	3.3	3.9				
PK245M-02AA PK245M-02BA	Bipolar (Series)	0.38	53	0.57	8.6	15	39.6	68×10 ⁻⁷	0.37	6	-
	Unipolar	0.32	45	0.8	6	7.5	9.9				
PK245M-03AA PK245M-03BA	Bipolar (Series)	0.38	53	0.28	17	60	128	68×10 ⁻⁷	0.37	6	-
	Unipolar	0.32	45	0.4	12	30	32				

- Wirings and connections → Page A-288
Encoder specifications → Page A-17
- Enter **A** (single shaft) or **B** (double shaft) in the box (□) within the model name.
Enter the encoder code (**15**, **16**, **25** or **26**) in the box (□) within the model name.
- Product Number Code → Page A-278

Dimensions Unit = mm (in.)

The dimensions of a motor with an encoder can be found on page A-19 or at www.orientalmotor.com.

Model	L1	L2	Mass kg (lb.)	DXF
PK243M-0□AA PK243M-0□BA	33 (1.30)	— 48 (1.89)	0.24 (0.53)	B081U
PK244M-0□AA PK244M-0□BA	39 (1.54)	— 54 (2.13)	0.3 (0.66)	B082U
PK245M-0□AA PK245M-0□BA	47 (1.85)	— 62 (2.44)	0.37 (0.81)	B083U

- Enter the winding specification in the box (□) within the model name.

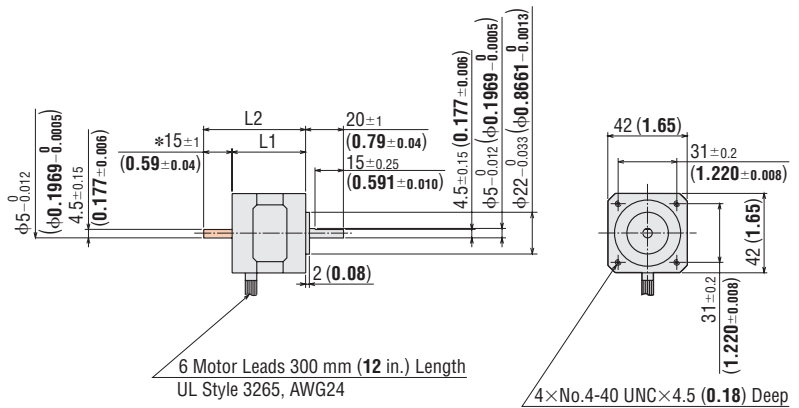

* The length of machining on the double shaft model is 15±0.25 (0.591±0.010).

- These dimensions are for the double shaft models. For the single shaft models, ignore the orange (□) area.

Speed – Torque Characteristics

PK243M-01 A / PK243MAAR

Bipolar (Series)

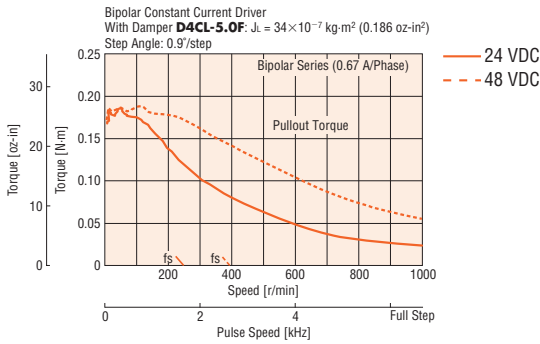

PK243M-01 A / PK243MAAR

Unipolar

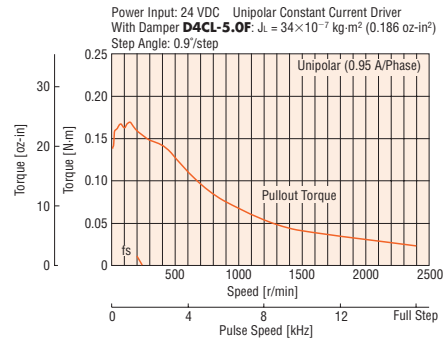

PK243M-02 A

Bipolar (Series)

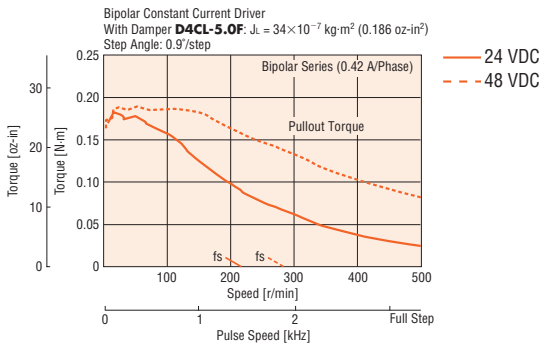

PK243M-02 A

Unipolar

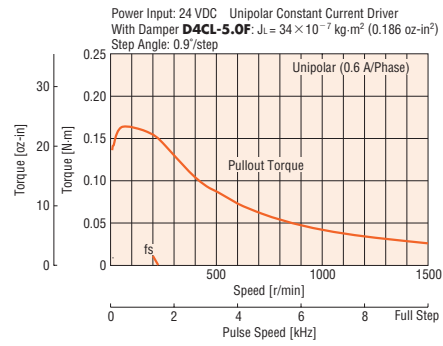

PK243M-03 A

Bipolar (Series)

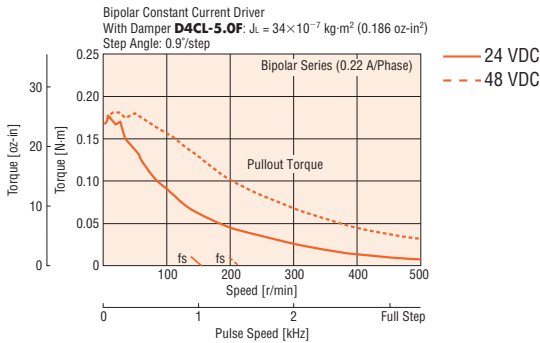

PK243M-03 A

Unipolar

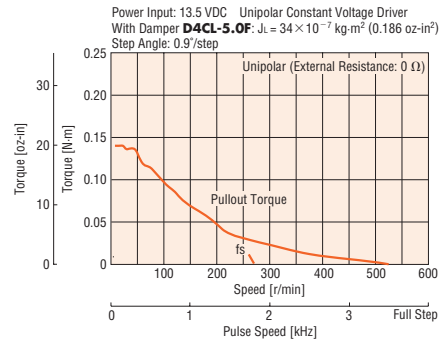

- Enter **A** (single shaft) or **B** (double shaft) in the box (□) within the model name.
- Enter the encoder code (**15**, **16**, **25** or **26**) in the box (■) within the model name.

Note

- Pay attention to heat dissipation from motor as there will be a considerable amount of heat under certain conditions. Be sure to keep the temperature of the motor case under 100°C (212°F).

Introduction	
AR	0.36° / Geared
AS	0.36° / Geared
RK	0.72° / Geared
UMK	0.9° / 1.8°
AR	0.36° / Geared
ASX	0.36° / Geared
CRK	0.36° / 0.72° / Geared
CMK	0.9° / 1.8° / Geared
RBK	1.8° / Geared
PK	0.36°
PK	0.72°
PK	0.9°
PK/PV	1.8°
PK	Geared
Controllers	SCX10 / EMP400 / SG80301
Accessories	

Speed – Torque Characteristics

PK244M-01 A / PK244MAAR

Bipolar (Series)

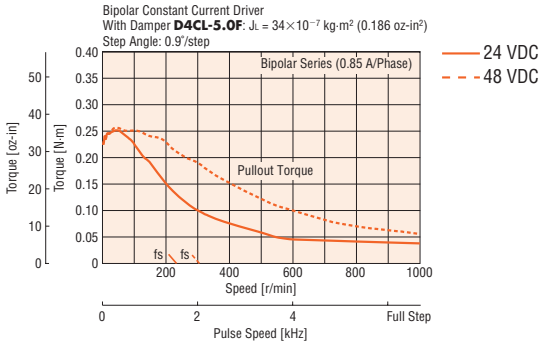

PK244M-01 A / PK244MAAR

Unipolar

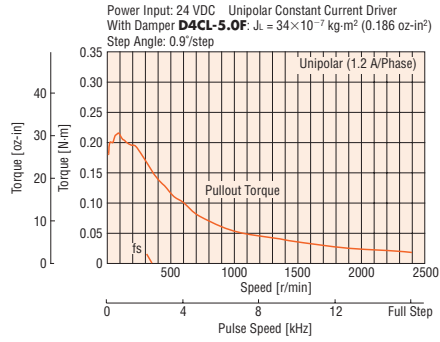

PK244M-02 A

Bipolar (Series)

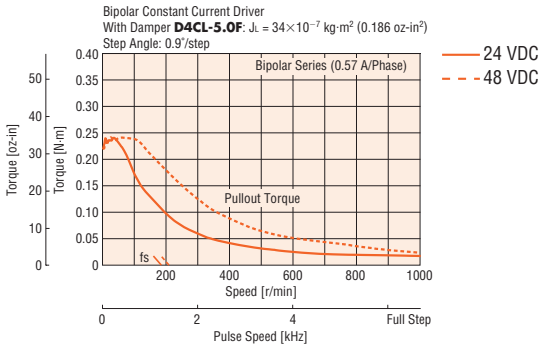

PK244M-02 A

Unipolar

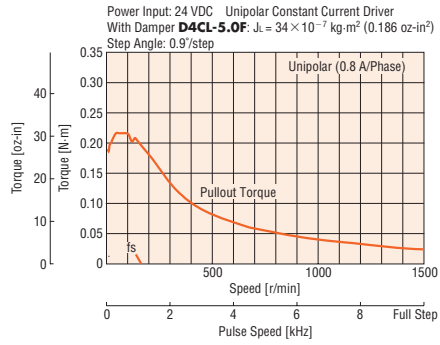

PK244M-03 A

Unipolar

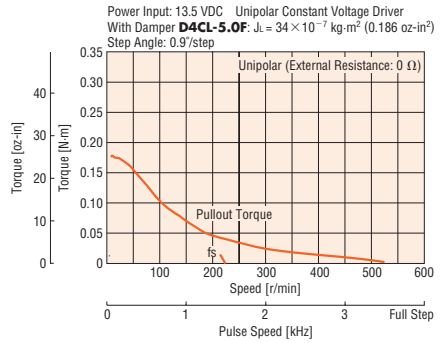

- Enter **A** (single shaft) or **B** (double shaft) in the box () within the model name.
- Enter the encoder code (**15**, **16**, **25** or **26**) in the box () within the model name.

Note

- Pay attention to heat dissipation from motor as there will be a considerable amount of heat under certain conditions. Be sure to keep the temperature of the motor case under 100°C (212°F).

20 mm
(0.79 in.)

28 mm
(1.10 in.)

35 mm
(1.38 in.)

42 mm
(1.65 in.)

50 mm
(1.97 in.)

56.4 mm
(2.22 in.)

60 mm
(2.36 in.)

85 mm
(3.35 in.)

90 mm
(3.54 in.)

PK245M-01 A / PK245MAAR

Bipolar (Series)

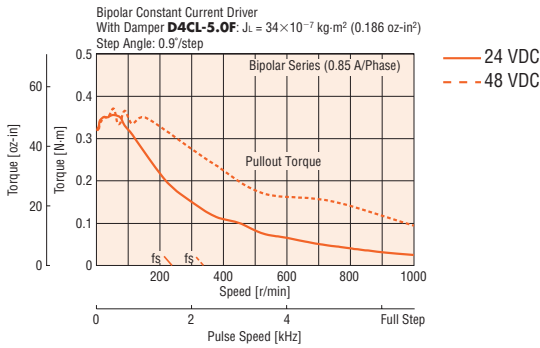

PK245M-02 A

Bipolar (Series)

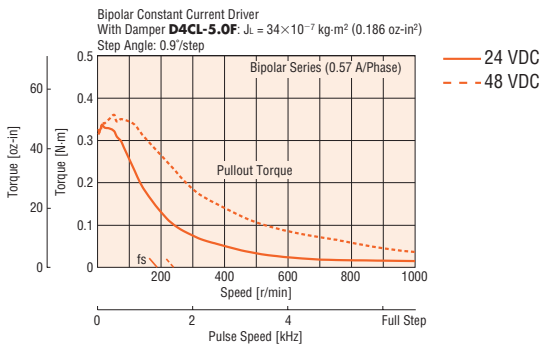

PK245M-01 A / PK245MAAR

Unipolar

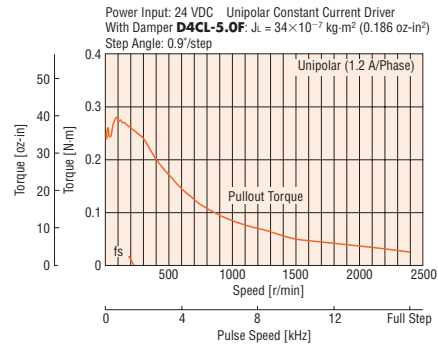

PK245M-02 A

Unipolar

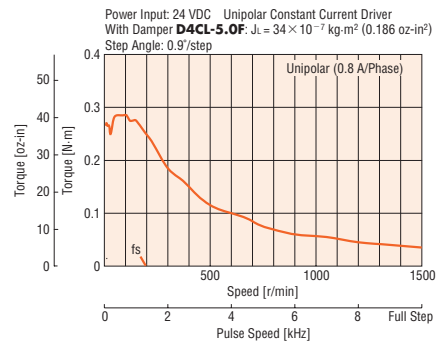

PK245M-03 A

Unipolar

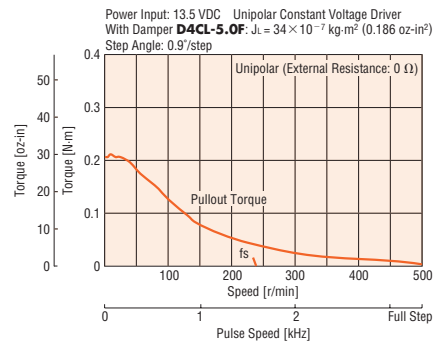

- Enter **A** (single shaft) or **B** (double shaft) in the box () within the model name.
- Enter the encoder code (**15**, **16**, **25** or **26**) in the box () within the model name.

Note

- Pay attention to heat dissipation from motor as there will be a considerable amount of heat under certain conditions. Be sure to keep the temperature of the motor case under 100°C (212°F).

Introduction	AC Input Motor & Driver	Motor Only
AR	0.36° / Geared	PK
AS	0.36° / Geared	PK
RK	0.72° / Geared	PK
UMK	0.9°/1.8°	PK
AR	0.36° / Geared	PK
ASX	0.36° / Geared	PK
CRK	0.36°/0.72° / Geared	PK
CMK	0.9°/1.8° / Geared	PK
RBK	1.8° / Geared	PK
PK	0.36°	PK
PK	0.72°	PK
PK	0.9°	PK
PK/PV	1.8°	PK
PK	Geared	PK
SCX10 / EMP400 / SG80301	Controllers	SCX10 / EMP400 / SG80301
Accessories	Accessories	

Step Angle 0.9°

Motor Frame Size 56.4 mm (2.22 in.)

PK Series Standard Type



- 20 mm (0.79 in.)
- 28 mm (1.10 in.)
- 35 mm (1.38 in.)
- 42 mm (1.65 in.)
- 50 mm (1.97 in.)
- 56.4 mm (2.22 in.)
- 60 mm (2.36 in.)
- 85 mm (3.35 in.)
- 90 mm (3.54 in.)

Specifications RoHS

Model	Connection Type	Holding Torque		Rated Current	Voltage	Resistance	Inductance	Rotor Inertia J		Lead Wires	Corresponding AC/DC-Input Motor & Driver Package
		N·m	oz·in					kg·m ²	oz·in ²		
PK264M-01A PK264M-01B	Bipolar (Series)	0.48	68	0.71	8.1	11.4	26	120×10 ⁻⁷	0.66	6	-
	Unipolar	0.39	55	1	5.7	5.7	6.5				
PK264M-02A PK264M-02B PK264MAR□	Bipolar (Series)	0.48	68	1.4	3.9	2.8	6.8	120×10 ⁻⁷	0.66	6	UMK264M□A/ CMK264M□P/ CMK264MAP-R□
	Unipolar	0.39	55	2	2.8	1.4	1.7				
PK264M-03A PK264M-03B	Bipolar (Series)	0.48	68	2.1	2.6	1.26	3	120×10 ⁻⁷	0.66	6	-
	Unipolar	0.39	55	3	1.9	0.63	0.75				
PK264M-E2.0A PK264M-E2.0B	Bipolar (Parallel)	0.48	68	2.8	1.96	0.7	1.7	120×10 ⁻⁷	0.66	8	-
	Bipolar (Series)	0.48	68	1.4	3.9	2.8	6.8				
	Unipolar	0.39	55	2	2.8	1.4	1.7				
PK266M-01A PK266M-01B	Bipolar (Series)	1.17	166	0.71	11	14.8	50.8	300×10 ⁻⁷	1.64	6	-
	Unipolar	0.9	127	1	7.4	7.4	12.7				
PK266M-02A PK266M-02B PK266MAR□	Bipolar (Series)	1.17	166	1.4	5	3.6	12.8	300×10 ⁻⁷	1.64	6	UMK266M□A/ CMK266M□P/ CMK266MAP-R□
	Unipolar	0.9	127	2	3.6	1.8	3.2				
	Bipolar (Series)	1.17	166	2.1	3.2	1.5	5.8				
PK266M-03A PK266M-03B	Unipolar	0.9	127	3	2.3	0.75	1.45	300×10 ⁻⁷	1.64	6	-
	Bipolar (Parallel)	1.17	166	2.8	2.52	0.9	3.2				
PK266M-E2.0A PK266M-E2.0B	Bipolar (Series)	1.17	166	1.4	5	3.6	12.8	300×10 ⁻⁷	1.64	8	-
	Bipolar (Series)	1.17	166	1.4	5	3.6	12.8				
	Unipolar	0.9	127	2	3.6	1.8	3.2				
PK268M-01A PK268M-01B	Bipolar (Series)	1.75	240	0.71	12	17.2	77.6	480×10 ⁻⁷	2.6	6	-
	Unipolar	1.35	191	1	8.6	8.6	19.4				
PK268M-02A PK268M-02B PK268MAR□	Bipolar (Series)	1.75	240	1.4	6.3	4.5	19.2	480×10 ⁻⁷	2.6	6	UMK268M□A/ CMK268M□P/ CMK268MAP-R□
	Unipolar	1.35	191	2	4.5	2.25	4.8				
	Bipolar (Series)	1.75	240	2.1	4.2	2	8.4				
PK268M-03A PK268M-03B	Unipolar	1.35	191	3	3	1	2.1	480×10 ⁻⁷	2.6	6	-
	Bipolar (Parallel)	1.75	240	2.8	3.16	1.13	4.8				
PK268M-E2.0A PK268M-E2.0B	Bipolar (Series)	1.75	240	1.4	6.3	4.5	19.2	480×10 ⁻⁷	2.6	8	-
	Bipolar (Series)	1.75	240	1.4	6.3	4.5	19.2				
	Unipolar	1.35	191	2	4.5	2.25	4.8				

- Wirings and connections → Page A-288
- Encoder specifications → Page A-17
- Enter **A** (single shaft) or **B** (double shaft) in the box (□) within the model name.
- Enter the encoder code (**15**, **16**, **25** or **26**) in the box (□) within the model name.
- Product Number Code → Page A-278

Dimensions Unit = mm (in.)

The dimensions of a motor with an encoder can be found on page A-19 or at www.orientalmotor.com.

Model	L1	L2	Mass kg (lb.)	DXF
PK264M-0□A PK264M-E2.0A	39 (1.54)	-	0.45 (0.99)	B084
PK264M-0□B PK264M-E2.0B		55 (2.17)		
PK266M-0□A PK266M-E2.0A	54 (2.13)	-	0.7 (1.54)	B085
PK266M-0□B PK266M-E2.0B		70 (2.76)		
PK268M-0□A PK268M-E2.0A	76 (2.99)	-	1 (2.2)	B086
PK268M-0□B PK268M-E2.0B		92 (3.62)		

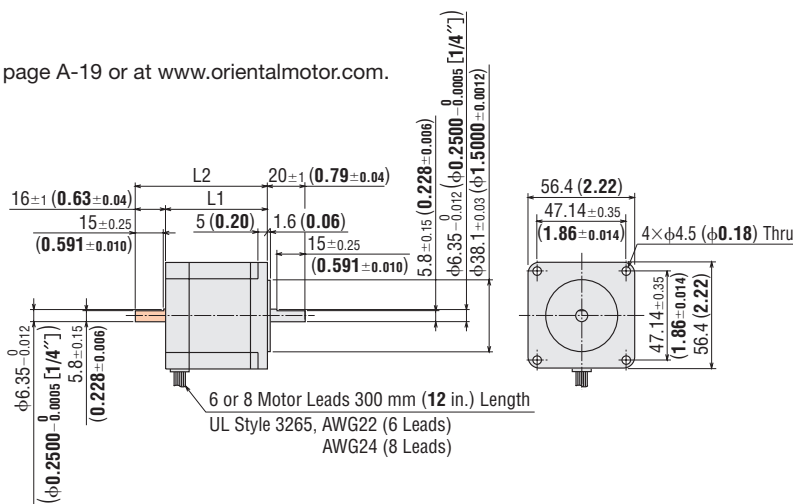

- Enter the winding specification in the box (□) within the model name.
- These dimensions are for the double shaft models. For the single shaft models, ignore the orange (■) area.

Speed – Torque Characteristics

PK264M-01

Bipolar (Series)

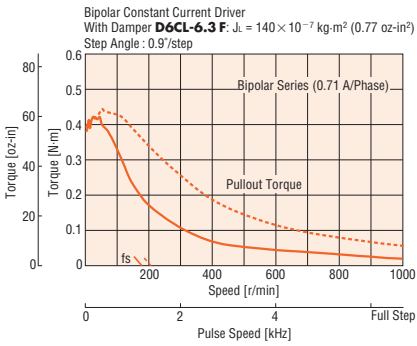

PK264M-01

Unipolar

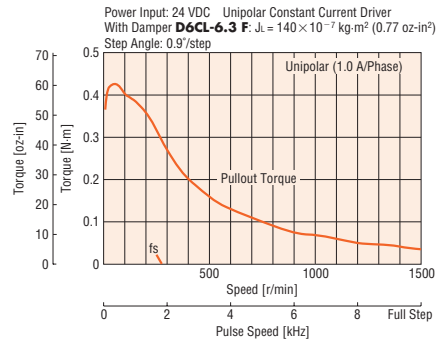

PK264M-02 /PK264MAR

Bipolar (Series)

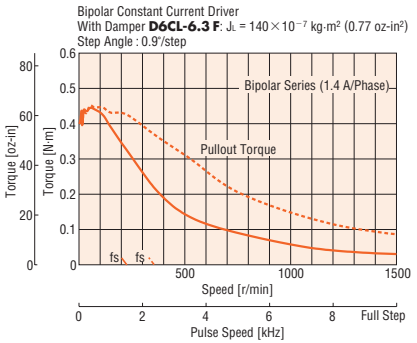

PK264M-02 /PK264MAR

Unipolar

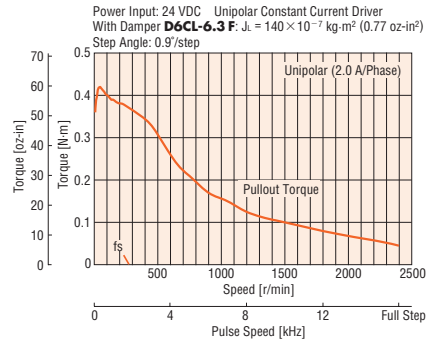

PK264M-03

Bipolar (Series)

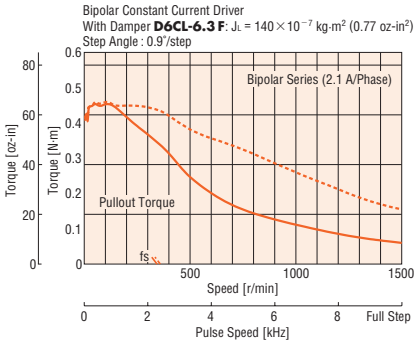

PK264M-03

Unipolar

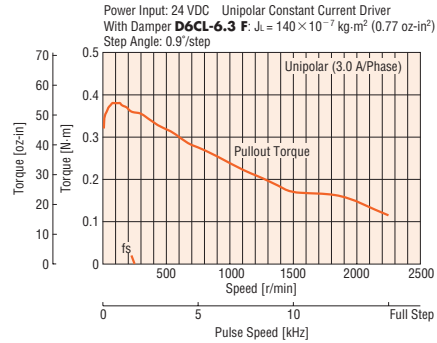

PK264M-E2.0

Bipolar (Parallel)

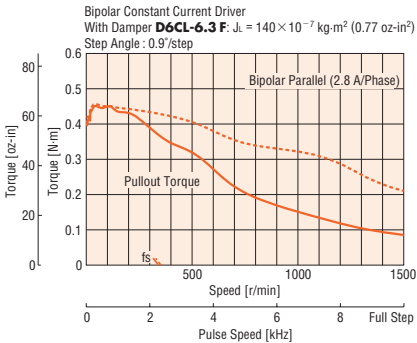

PK264M-E2.0

Bipolar (Series)

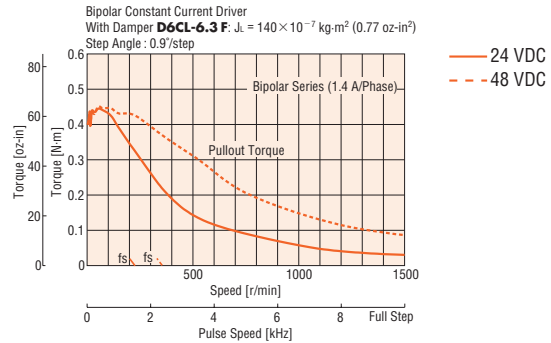

- Enter **A** (single shaft) or **B** (double shaft) in the box () within the model name.
- Enter the encoder code (**15**, **16**, **25** or **26**) in the box () within the model name.

Note

- Pay attention to heat dissipation from motor as there will be a considerable amount of heat under certain conditions.
- Be sure to keep the temperature of the motor case under 100°C (212°F).

Introduction	
AR	0.36° / Geared
AS	0.36° / Geared
RK	0.72° / Geared
UMK	0.9°/1.8°
AR	0.36° / Geared
ASX	0.36° / Geared
CRK	0.36°/0.72° / Geared
CMK	0.9°/1.8° / Geared
RBK	1.8° / Geared
PK	0.36°
PK	0.72°
PK	0.9°
PK/PV	1.8°
PK	Geared
Controllers	SCX10 / EMP400 / SG80301
Accessories	

Speed – Torque Characteristics

PK266M-01

Bipolar (Series)

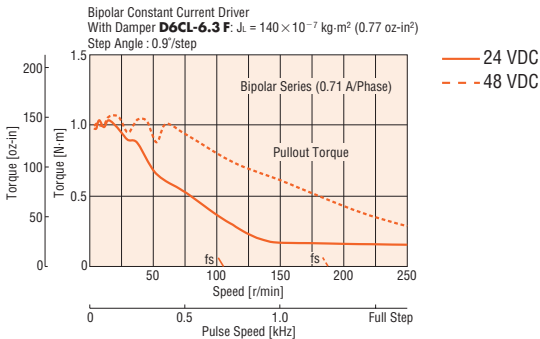

PK266M-01

Unipolar

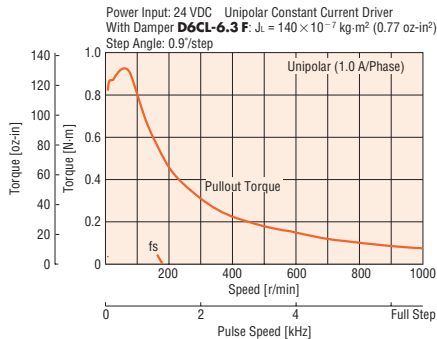

PK266M-02 /PK266MAR

Bipolar (Series)

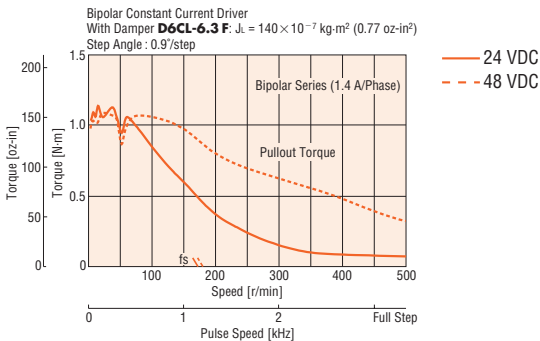

PK266M-02 /PK266MAR

Unipolar

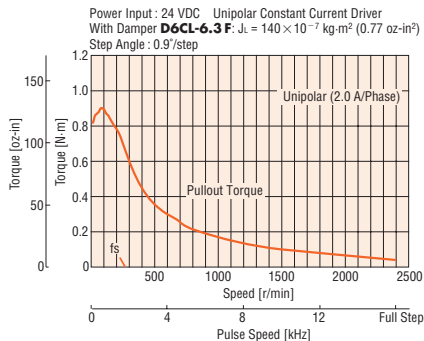

PK266M-03

Bipolar (Series)

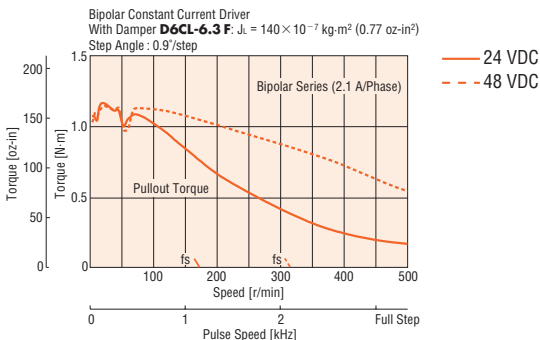

PK266M-03

Unipolar

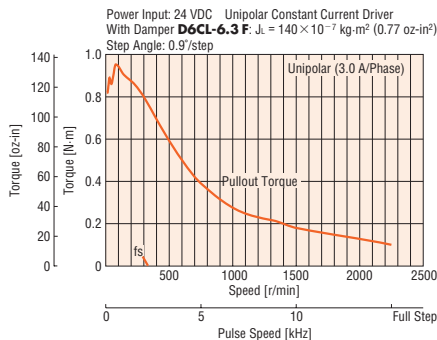

PK266M-E2.0

Bipolar (Parallel)

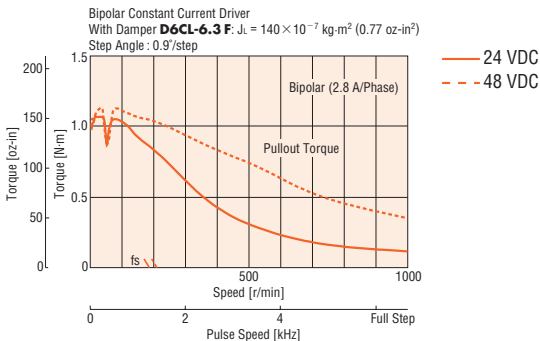

PK266M-E2.0

Bipolar (Series)

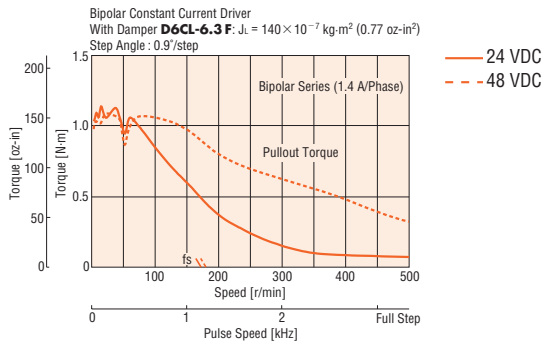

● Enter **A** (single shaft) or **B** (double shaft) in the box (□) within the model name.
Enter the encoder code (**15**, **16**, **25** or **26**) in the box (▣) within the model name.

Note

● Pay attention to heat dissipation from motor as there will be a considerable amount of heat under certain conditions.
Be sure to keep the temperature of the motor case under 100°C (212°F).

□ 20 mm
(0.79 in.)

□ 28 mm
(1.10 in.)

□ 35 mm
(1.38 in.)

□ 42 mm
(1.65 in.)

□ 50 mm
(1.97 in.)

□ 56.4 mm
(2.22 in.)

□ 60 mm
(2.36 in.)

□ 85 mm
(3.35 in.)

□ 90 mm
(3.54 in.)

PK268M-01

Bipolar (Series)

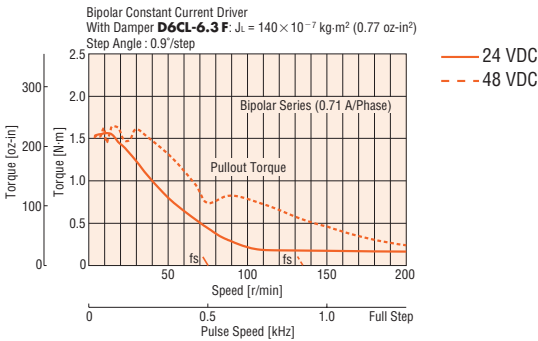

PK268M-02 /PK268MAR

Bipolar (Series)

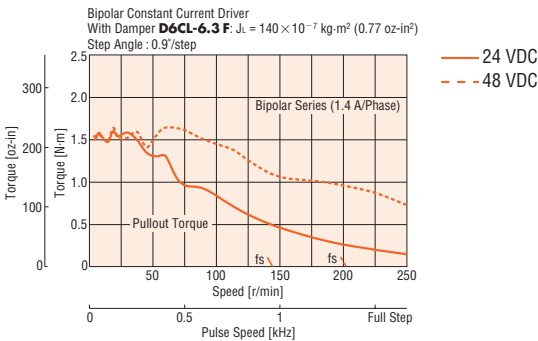

PK268M-03

Bipolar (Series)

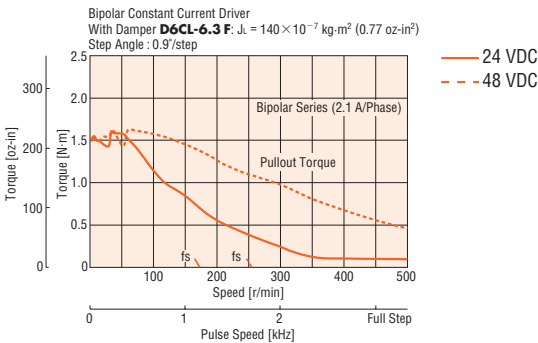

PK268M-E2.0

Bipolar (Parallel)

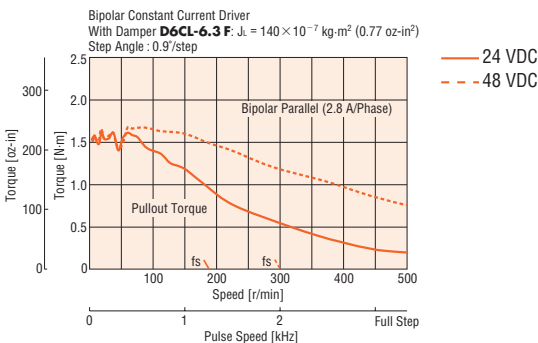

PK268M-01

Unipolar

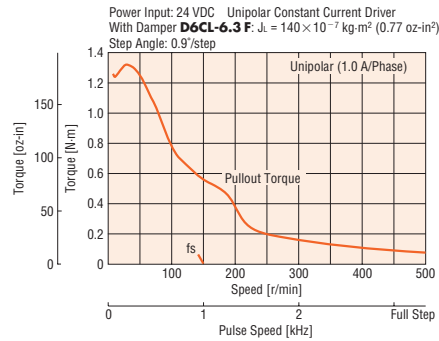

PK268M-02 /PK268MAR

Unipolar

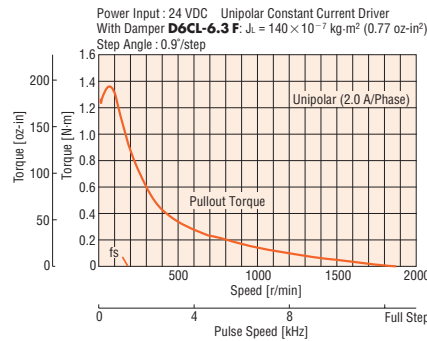

PK268M-03

Unipolar

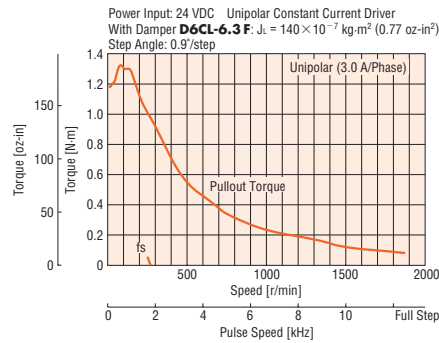

PK268M-E2.0

Bipolar (Series)

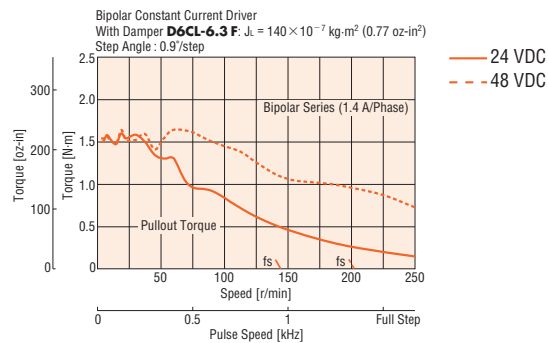

- Enter **A** (single shaft) or **B** (double shaft) in the box (□) within the model name.
- Enter the encoder code (**15**, **16**, **25** or **26**) in the box (▣) within the model name.

Note

- Pay attention to heat dissipation from motor as there will be a considerable amount of heat under certain conditions. Be sure to keep the temperature of the motor case under 100°C (212°F).

Introduction	
AR	AC Input Motor & Driver
AR	0.36° / Geared
AS	0.72° / Geared
RK	0.9°/1.8°
UMK	0.9°/1.8°
AR	0.36° / Geared
ASX	0.36° / Geared
CRK	0.36°/0.72° / Geared
CMK	0.9°/1.8° / Geared
RBK	1.8° / Geared
PK	0.36°
PK	0.72°
PK	0.9°
PK/PV	1.8°
PK	Geared
SCX10 / EMP400 / SG80301	Controllers
	Accessories

Step Angle 1.8°

Motor Frame Size 42 mm (1.65 in.)

PK Series High-Torque, High-Efficiency Type



Specifications (RoHS)

Model • Single Shaft • Double Shaft	Connection Type	Holding Torque		Rated Current A/phase	Voltage VDC	Resistance Ω/phase	Inductance mH/phase	Rotor Inertia J		Lead Wires (Pins)
		N-m	oz-in					kg·m ²	oz-in ²	
PKE243DA-L PKE243DB-L	Bipolar	0.3	42	1.5	1.93	1.29	3.7	36 × 10 ⁻⁷	0.197	4
PKE243A-L PKE243B-L	Bipolar (Series) Unipolar	0.24	34	0.67 0.95	4.42 3.14	6.6 3.3	18.8 4.7			6
PKE244DA-L PKE244DB-L	Bipolar	0.48	68	1.5	3.9	2.6	6.25	57 × 10 ⁻⁷	0.31	4
PKE244A-L PKE244B-L	Bipolar (Series) Unipolar	0.39	55	0.85 1.2	6.8 4.8	8 4	19.4 4.85			6
PKE245DA-L PKE245DB-L	Bipolar	0.55	78	1.5	2.9	1.94	7	83 × 10 ⁻⁷	0.45	4
PKE245A-L PKE245B-L	Bipolar (Series) Unipolar	0.44	62	0.85 1.2	4.59 3.24	5.4 2.7	19.2 4.8			6

- Wirings and connections → Page A-288
- Connection cable assembly of 0.6 m (2 ft.) is included.

Dimensions Unit = mm (in.)

Model	L1	L2	Mass kg (lb.)	DXF
PKE243DA-L PKE243DB-L PKE243A-L PKE243B-L	33 (1.3)	— 48 (1.89) — 48 (1.89)	0.27 (0.59)	B570
PKE244DA-L PKE244DB-L PKE244A-L PKE244B-L	39 (1.54)	— 54 (2.13) — 54 (2.13)	0.32 (0.70)	B331
PKE245DA-L PKE245DB-L PKE245A-L PKE245B-L	47 (1.85)	— 62 (2.44) — 62 (2.44)	0.41 (0.90)	B571

- Applicable Connector
Connector housing: 51103-0600 (MOLEX)
Contact: 50351-8100 (MOLEX)
Crimp tool: 57295-5000 (MOLEX)

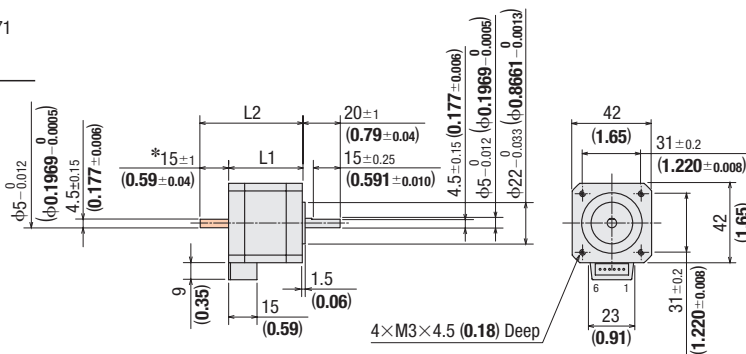

- Connection Cable (included)

LC2B06B

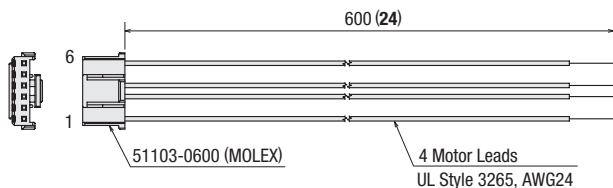

LC2U06B

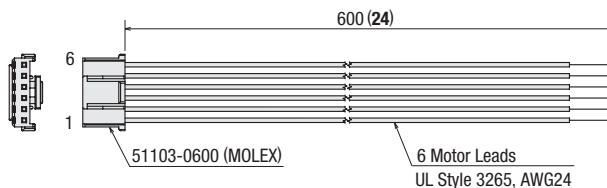

- These dimensions are for the double shaft models. For single shaft models, ignore the shaded () area.

Speed – Torque Characteristics

PKE243D

Bipolar

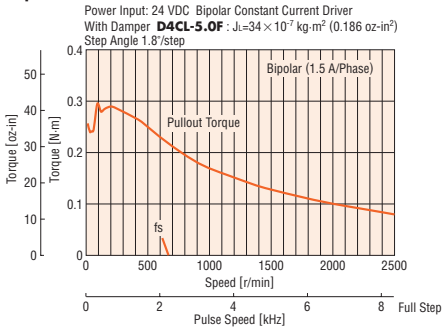

PKE243

Bipolar (Series)

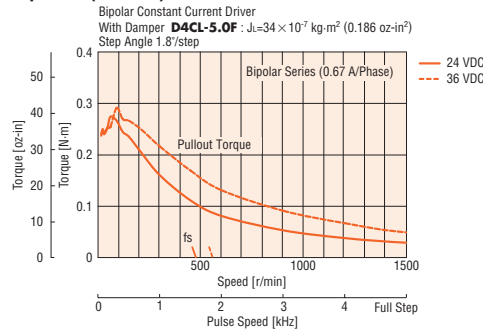

PKE243

Unipolar

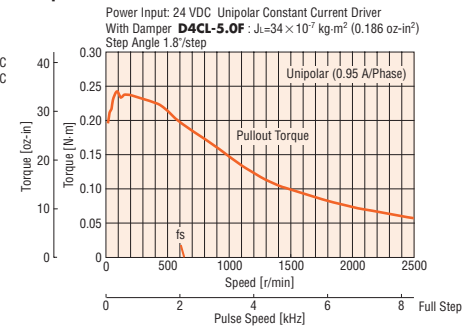

PKE244D

Bipolar

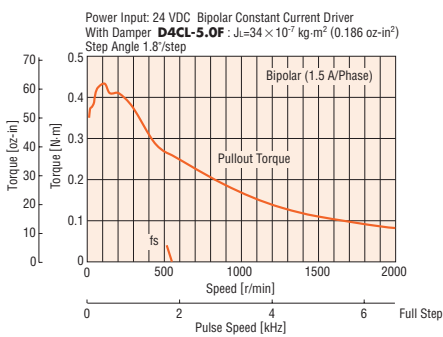

PKE244

Bipolar (Series)

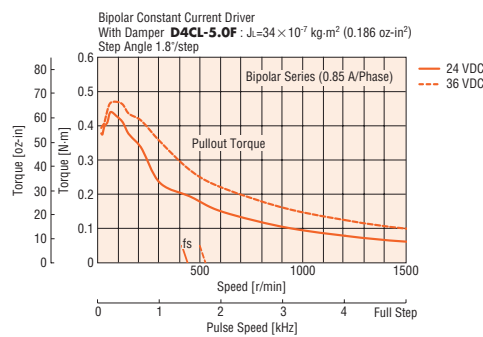

PKE244

Unipolar

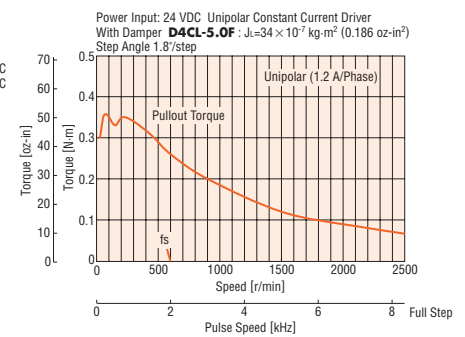

PKE245D

Bipolar

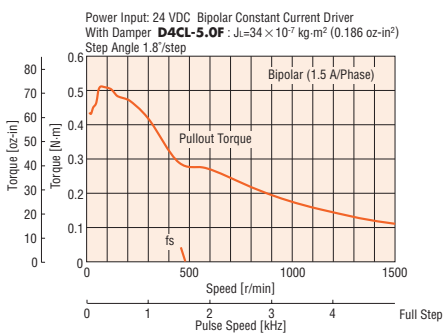

PKE245

Bipolar (Series)

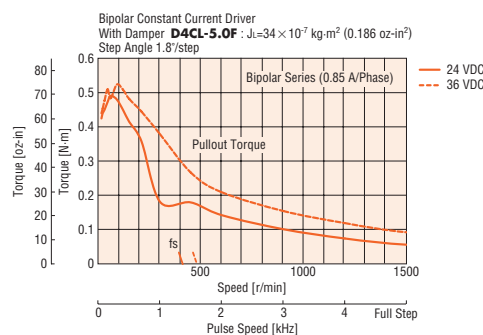

PKE245

Unipolar

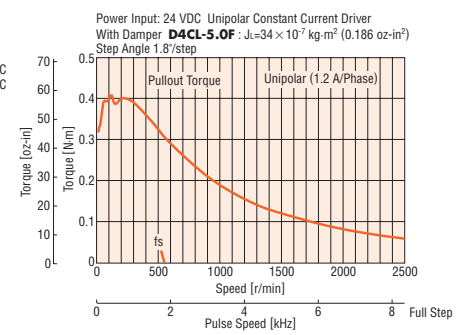

Accessories (Sold separately)

The connection cable is available as an accessory.

- Connection cable → Page A-409

Introduction

AR
CSTEP
AS

AC Input Motor & Driver

RK
0.72°
/Geared

UMK
0.9°/1.8°

AR
CSTEP
/Geared

ASX
CSTEP
0.36°

CRK
/Geared
0.36°/0.72°

CMK
/Geared
0.9°/1.8°

RBK
/Geared
1.8°

PK
0.36°

PK
0.72°

PK
0.9°

PK/PV
1.8°

PK
Geared

Controllers
SCX10
EMP400
/SG80301

Accessories

Motor Only

Step Angle 1.8°

Motor Frame Size 20 mm (0.79 in.)

PK Series High-Torque Type



20 mm (0.79 in.)

28 mm (1.10 in.)

35 mm (1.38 in.)

42 mm (1.65 in.)

50 mm (1.97 in.)

56.4 mm (2.22 in.)

60 mm (2.36 in.)

85 mm (3.35 in.)

90 mm (3.54 in.)

Specifications RoHS

Model • Single Shaft • Double Shaft	Connection Type	Holding Torque		Rated Current A/phase	Voltage VDC	Resistance Ω/phase	Inductance mH/phase	Rotor Inertia J		Lead Wires
		N·m	oz·in					kg·m ²	oz·in ²	
PK213PDA PK213PDB	Bipolar	0.02	2.8	0.5	4.25	8.5	4.1	1.6×10 ⁻⁷	0.0088	4
PK213PA PK213PB	Unipolar	0.014	1.98							5
PK214PDA PK214PDB	Bipolar	0.036	5.1	0.6	3.9	6.5	3.5	2.9×10 ⁻⁷	0.0159	4
PK214PA PK214PB	Unipolar	0.026	3.6							5

• Wirings and connections → Page A-288

Speed – Torque Characteristics

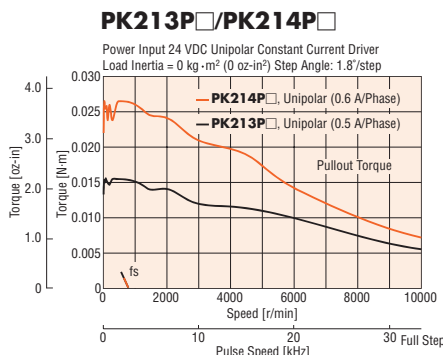
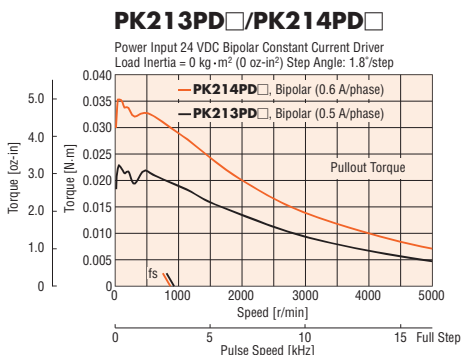

• Enter **A** (single shaft) or **B** (double shaft) in the box (□) within the model name.

Dimensions Unit = mm (in.)

Model	L1	L2	Mass kg (lb.)	DXF
PK213PDA, PK213PA PK213PDB, PK213PB	30 (1.18)	— 38 (1.50)	0.05 (0.11)	B611
PK214PDA, PK214PA PK214PDB, PK214PB	40 (1.57)	— 48 (1.89)	0.07 (0.154)	B792

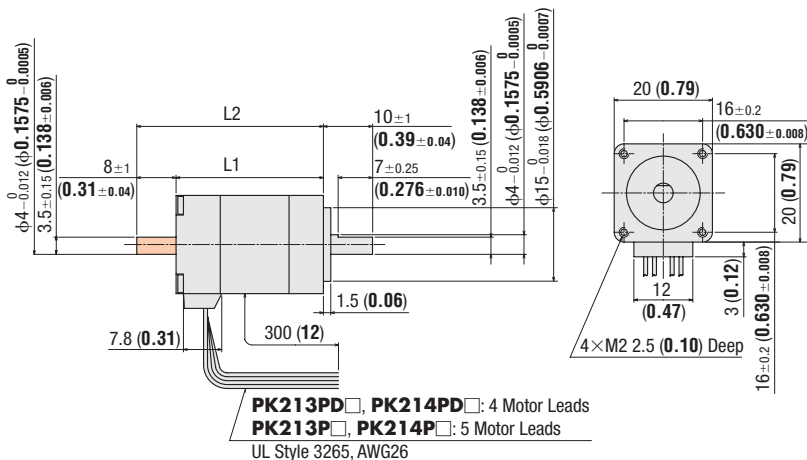

• These dimensions are for the double shaft models. For the single shaft models, ignore the orange (■) area.

Step Angle 1.8° Motor Frame Size 28 mm (1.10 in.) PK Series High-Torque Type



Specifications (RoHS)

Model • Single Shaft • Double Shaft • with Encoder	Connection Type	Holding Torque		Rated Current A/phase	Voltage VDC	Resistance Ω/phase	Inductance mH/phase	Rotor Inertia J		Lead Wires (Pins)	Corresponding DC-Input Motor & Driver Package CMK Series
		N-m	oz-in					kg-m ²	oz-in ²		
PK223PA PK223PB PK223PAR15	Bipolar (Series)	0.065	9.2	0.67	3.8	5.6	4	9×10 ⁻⁷	0.049	6	CMK223P□P/ CMK223PAP-R15
	Unipolar	0.05	7.1	0.95	2.66	2.8	1				
PK224PA PK224PB PK224PAR15	Bipolar (Series)	0.097	13.7	0.67	4.6	6.8	4.8	12×10 ⁻⁷	0.066	6	CMK224P□P/ CMK224PAP-R15
	Unipolar	0.075	10.6	0.95	3.2	3.4	1.2				
PK225PA PK225PB PK225PAR15	Bipolar (Series)	0.11	15.6	0.67	6.2	9.2	5.6	18×10 ⁻⁷	0.098	6	CMK225P□P/ CMK225PAP-R15
	Unipolar	0.09	12.7	0.95	4.4	4.6	1.4				

- Wirings and connections → Page A-288
- Encoder specifications → Page A-17
- Enter **A** (single shaft) or **B** (double shaft) in the box (□) within the model name.
- Product Number Code → Page A-278

Dimensions Unit = mm (in.)

The dimensions of a motor with an encoder can be found on page A-19 or at www.orientalmotor.com.

Model	L1	L2	Mass kg (lb.)	DXF
PK223PA	32 (1.26)	—	0.11 (0.24)	B326
PK223PB		42 (1.65)		
PK224PA	40 (1.57)	—	0.14 (0.31)	B327
PK224PB		50 (1.97)		
PK225PA	51.5 (2.03)	—	0.2 (0.44)	B328
PK225PB		61.5 (2.42)		

- Lead wire and connector are not supplied with the connector-coupled motor and must be purchased separately. Connection cable is available as an accessory (sold separately).
- Applicable Connector
Connector housing: 51065-0600 (MOLEX)
Contact: 50212-8100 (MOLEX)
Crimp tool: 57176-5000 (MOLEX)

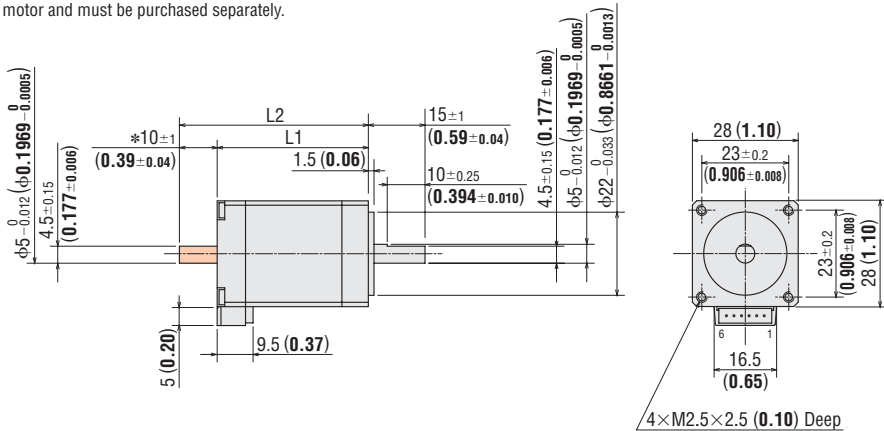

* The length of machining on the double shaft model is $10_{\pm 0.25}$ (0.394 ± 0.010).

- These dimensions are for the double shaft models. For the single shaft models, ignore the orange () area.

Accessories (Sold separately)

The connection cable is available as an accessory.

- Connection cable → Page A-409

Introduction	AC Input Motor & Driver	DC Input Motor & Driver	Motor Only
AR	0.36° / Geared	0.36° / Geared	0.36°
AS	0.72° / Geared	0.36° / Geared	0.72°
UMK	0.9° / 1.8°	0.9° / 1.8°	0.9°
AR	0.36° / Geared	0.36° / Geared	0.36°
ASX	0.36° / Geared	0.36° / Geared	0.36°
CRK	0.36° / 0.72° / Geared	0.36° / 0.72° / Geared	0.36° / 0.72°
CMK	0.9° / 1.8° / Geared	0.9° / 1.8° / Geared	0.9° / 1.8°
RBK	1.8° / Geared	1.8° / Geared	1.8°
PK	0.36°	0.36°	0.36°
PK	0.72°	0.72°	0.72°
PK	0.9°	0.9°	0.9°
PK/PV	1.8°	1.8°	1.8°
PK	Geared	Geared	Geared
Controllers SCX10 EMP400 /SG80301	Accessories	Accessories	Accessories

- 20 mm (0.79 in.)
- 28 mm (1.10 in.)
- 35 mm (1.38 in.)
- 42 mm (1.65 in.)
- 50 mm (1.97 in.)
- 56.4 mm (2.22 in.)
- 60 mm (2.36 in.)
- 85 mm (3.35 in.)
- 90 mm (3.54 in.)

Speed – Torque Characteristics

PK223P□/PK223PAR15

Bipolar (Series)

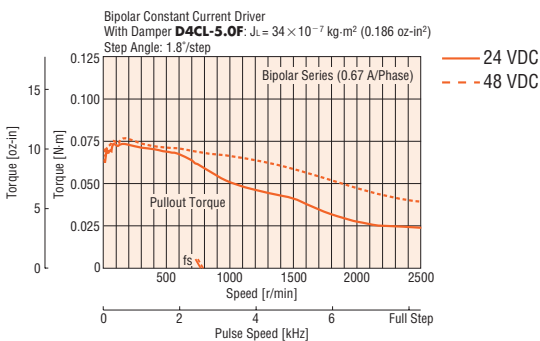

PK223P□/PK223PAR15

Unipolar

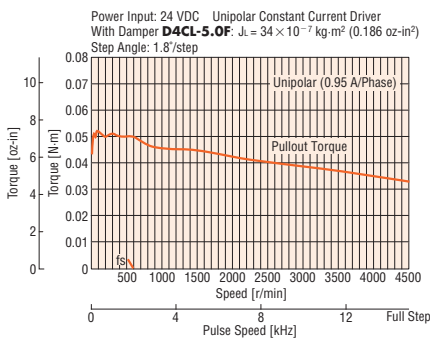

PK224P□/PK224PAR15

Bipolar (Series)

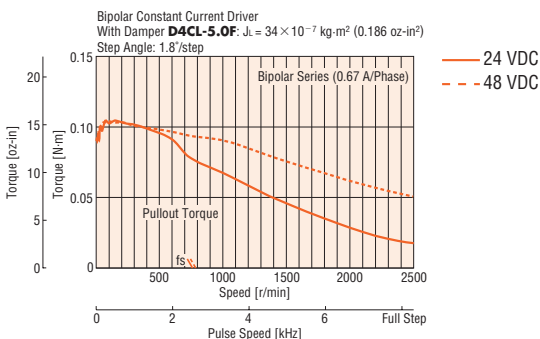

PK224P□/PK224PAR15

Unipolar

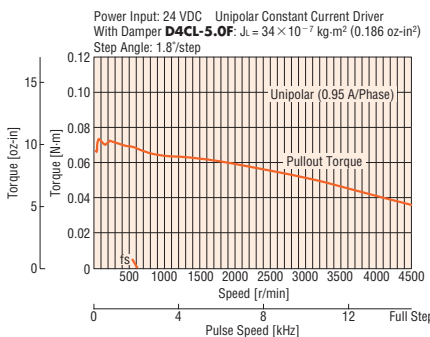

PK225P□/PK225PAR15

Bipolar (Series)

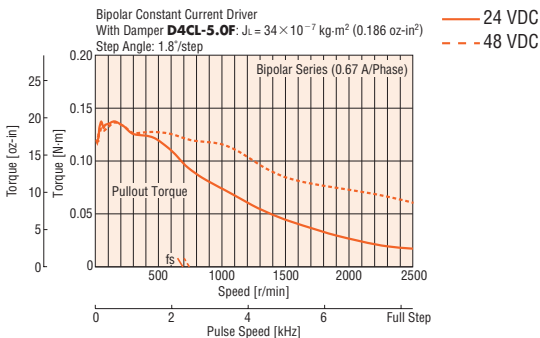

PK225P□/PK225PAR15

Unipolar

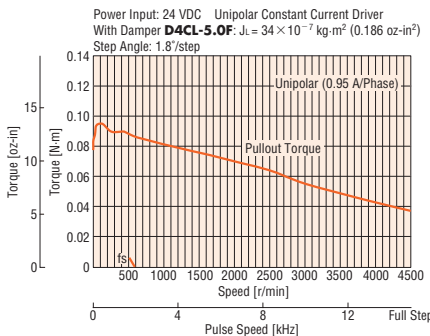

● Enter **A** (single shaft) or **B** (double shaft) in the box (□) within the model name.

Note

● Pay attention to heat dissipation from motor as there will be a considerable amount of heat under certain conditions.
Be sure to keep the temperature of the motor case under 100°C (212°F).

Step Angle 1.8°

Motor Frame Size 35 mm (1.38 in.)

PK Series High-Torque Type



Specifications RoHS

Model • Single Shaft • Double Shaft • with Encoder	Connection Type	Holding Torque		Rated Current	Voltage	Resistance	Inductance	Rotor Inertia J		Lead Wires (Pins)	Corresponding DC-Input Motor & Driver Package CMK Series
		N·m	oz·in					A/phase	VDC		
PK233PA PK233PB PK233PAR □	Bipolar (Series)	0.2	28	0.85	4.6	5.4	5.6	24×10 ⁻⁷	0.131	6	CMK233P □ P/ CMK233PAP -R □
	Unipolar	0.16	22	1.2	3.24	2.7	1.4				
PK235PA PK235PB PK235PAR □	Bipolar (Series)	0.37	52	0.85	5.8	6.8	8	50×10 ⁻⁷	0.27	6	CMK235P □ P/ CMK235PAP -R □
	Unipolar	0.3	42	1.2	4.08	3.4	2				

- Wirings and connections → Page A-288
- Encoder specifications → Page A-17
- Enter **A** (single shaft) or **B** (double shaft) in the box (□) within the model name.
- Enter the encoder code (**15**, **16**, **25** or **26**) in the box (□) within the model name.
- Product Number Code → Page A-278

Dimensions Unit = mm (in.)

The dimensions of a motor with an encoder can be found on page A-19 or at www.orientalmotor.com.

Model	L1	L2	Mass kg (lb.)	DXF
PK233PA PK233PB	37 (1.46)	—	0.18 (0.4)	B329
PK235PA PK235PB	52 (2.05)	—	0.285 (0.63)	B330
		67 (2.64)		

- Lead wire and connector are not supplied with the connector-coupled motor and must be purchased separately. Connection cable is available as an accessory (sold separately).
- Applicable Connector
Connector housing: 51103-0600 (MOLEX)
Contact: 50351-8100 (MOLEX)
Crimp tool: 57295-5000 (MOLEX)

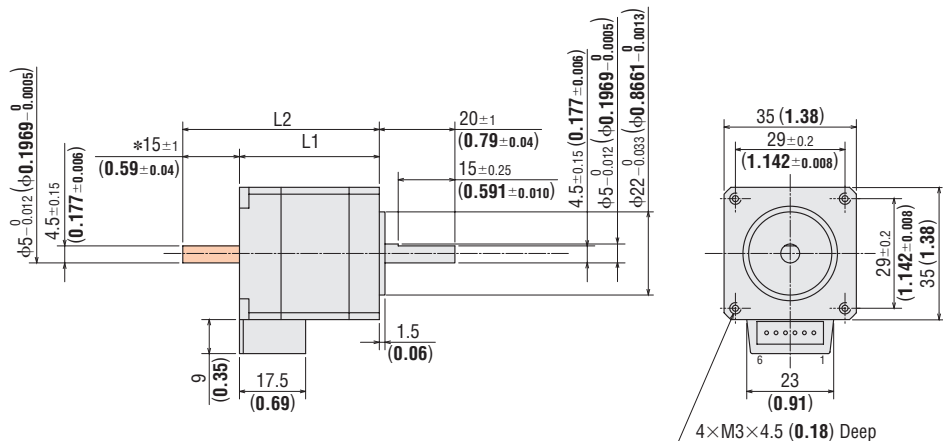

* The length of machining on the double shaft model is $15_{\pm 0.25}$ (0.591 ± 0.010).

- These dimensions are for the double shaft models. For the single shaft models, ignore the orange (■) area.

Accessories (Sold separately)

The connection cable is available as an accessory.

- Connection cable → Page A-409

Introduction	AC Input Motor & Driver	DC Input Motor & Driver	Motor Only	Controllers	Accessories
AR	0.36° / Geared	0.36° / Geared	0.36° / Geared	SCX10	
AS	0.72° / Geared	0.72° / Geared	0.72° / Geared	EMP400	
UMK	0.9° / 1.8°	0.9° / 1.8°	0.9° / 1.8°	SG8030J	
AR	0.36° / Geared	0.36° / Geared	1.8° / Geared		
ASX	0.36° / Geared	0.36° / Geared	0.9°		
CRK	0.36° / Geared	0.36° / Geared	0.9°		
CMK	0.36° / Geared	0.36° / Geared	1.8°		
RBK	0.36° / Geared	0.36° / Geared	1.8°		
PK	0.36°	0.36°	1.8°		
PK	0.72°	0.72°	1.8°		
PK	0.9°	0.9°	1.8°		
PK/PV	0.9°	0.9°	1.8°		
PK	Geared	Geared	Geared		

Speed – Torque Characteristics

PK233P□/PK233PAR□

Bipolar (Series)

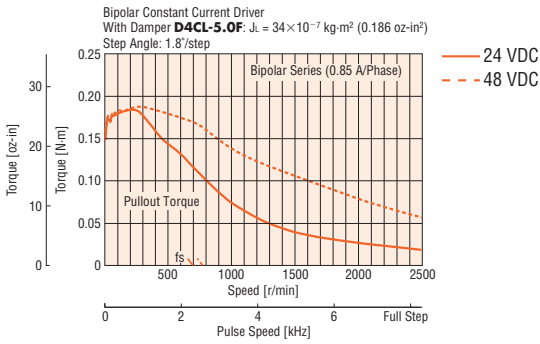

PK233P□/PK233PAR□

Unipolar

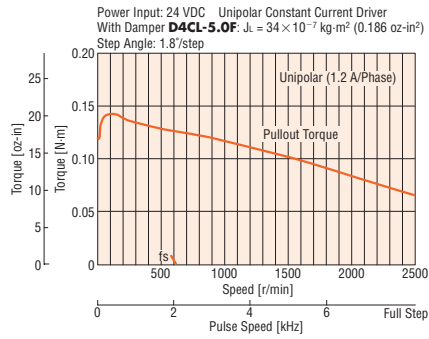

PK235P□/PK235PAR□

Bipolar (Series)

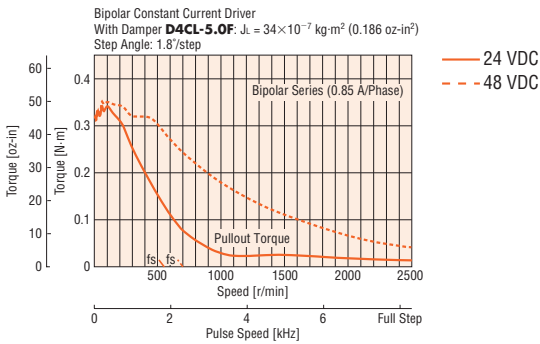

PK235P□/PK235PAR□

Unipolar

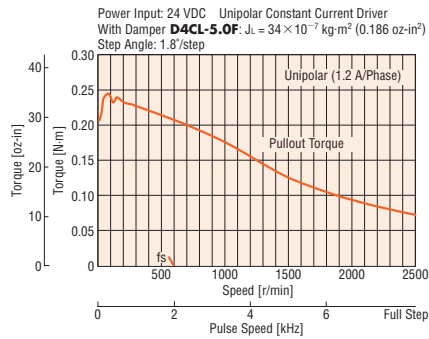

- Enter **A** (single shaft) or **B** (double shaft) in the box (□) within the model name.
- Enter the encoder code (**15**, **16**, **25** or **26**) in the box (□) within the model name.

Note

- Pay attention to heat dissipation from motor as there will be a considerable amount of heat under certain conditions. Be sure to keep the temperature of the motor case under 100°C (212°F).

□ 20 mm
□ 0.79 in.)

□ 28 mm
□ 1.10 in.)

□ 35 mm
□ 1.38 in.)

□ 42 mm
□ 1.65 in.)

□ 50 mm
□ 1.97 in.)

□ 56.4 mm
□ 2.22 in.)

□ 60 mm
□ 2.36 in.)

□ 85 mm
□ 3.35 in.)

□ 90 mm
□ 3.54 in.)

Step Angle 1.8°

Motor Frame Size 42 mm (1.65 in.)

PK Series High-Torque Type



Specifications RoHS

Model • Single Shaft • Double Shaft • with Encoder	Connection Type	Holding Torque		Rated Current A/phase	Voltage VDC	Resistance Ω/phase	Inductance mH/phase	Rotor Inertia J		Lead Wires (Pins)	Corresponding DC-Input Motor & Driver Package CMK Series
		N·m	oz·in					kg·m ²	oz·in ²		
PK244PA PK244PB PK244PAR □	Bipolar (Series)	0.48	68	0.85	6.8	8	15.6	57×10 ⁻⁷	0.31	6	CMK244P □ / CMK244PAP-R □
	Unipolar	0.39	55	1.2	4.8	4	3.9				
PK246PA PK246PB PK246PAR □	Bipolar (Series)	0.93	132	0.85	10	12	26	114×10 ⁻⁷	0.62	6	CMK246P □ / CMK246PAP-R □
	Unipolar	0.75	106	1.2	7.2	6	6.5				

- Wirings and connections → Page A-288
- Encoder specifications → Page A-17
- Enter **A** (single shaft) or **B** (double shaft) in the box (□) within the model name.
- Enter the encoder code (**15**, **16**, **25** or **26**) in the box (□) within the model name.
- Product Number Code → Page A-278

Dimensions Unit = mm (in.)

The dimensions of a motor with an encoder can be found on page A-19 or at www.orientalmotor.com.

Model	L1	L2	Mass kg (lb.)	DXF
PK244PA PK244PB	39 (1.54)	— 54 (2.13)	0.3 (0.66)	B331
PK246PA PK246PB	59 (2.32)	— 74 (2.91)	0.5 (1.1)	B332

- Lead wire and connector are not supplied with the connector-coupled motor and must be purchased separately.
- Connection cable is available as an accessory (sold separately).
- Applicable Connector
- Connector housing: 51103-0600 (MOLEX)
- Contact: 50351-8100 (MOLEX)
- Crimp tool: 57295-5000 (MOLEX)

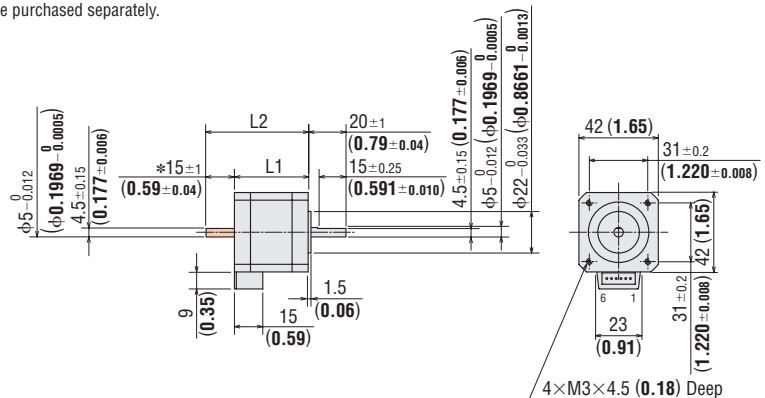

* The length of machining on the double shaft model is 15±0.25 (0.591±0.010).

- These dimensions are for the double shaft models. For the single shaft models, ignore the orange (■) area.

Accessories (Sold separately)

The connection cable is available as an accessory.

- Connection cable → Page A-409

Introduction	AC Input Motor & Driver	DC Input Motor & Driver	Motor Only
AR	0.36° / Geared	0.36° / Geared	PK
AS	0.72° / Geared	0.36° / Geared	PK
UMK	0.9° / 1.8°	0.9° / 1.8° / Geared	PK
AR	0.36° / Geared	0.36° / 0.72° / Geared	PK
ASX	0.36° / Geared	0.9° / 1.8° / Geared	PK
CRK	0.36° / Geared	1.8° / Geared	PK
CMK	0.9° / 1.8° / Geared	PK	PK
RBK	1.8° / Geared	PK	PK
PK	0.36°	PK	PK
PK	0.72°	PK	PK
PK	0.9°	PK	PK
PK/PV	1.8°	PK/PV	PK/PV
PK	Geared	PK	PK
Controllers SCX10 EMP400 /SG8030J			
Accessories			

Speed – Torque Characteristics

PK244P□/PK244PAR□

Bipolar (Series)

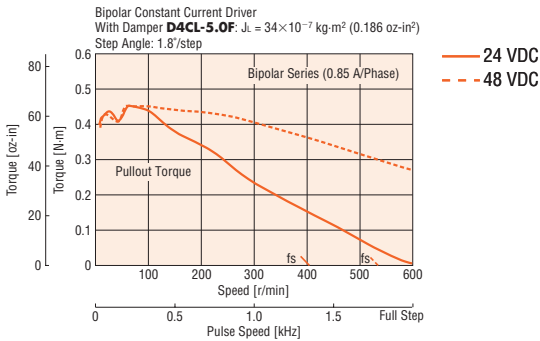

PK244P□/PK244PAR□

Unipolar

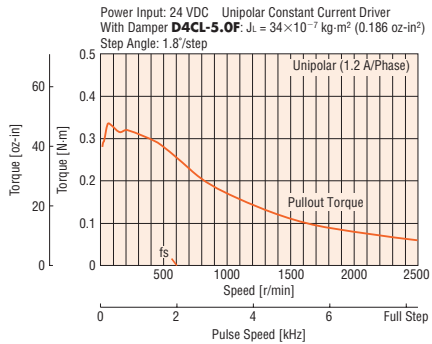

PK246P□/PK246PAR□

Bipolar (Series)

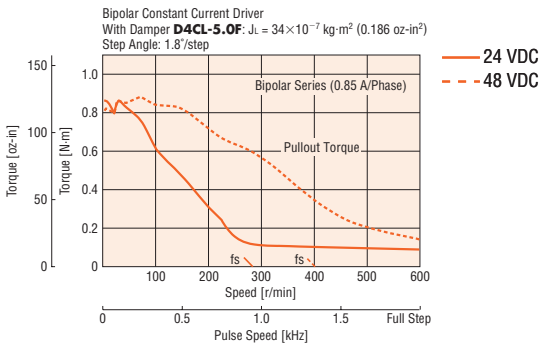

PK246P□/PK246PAR□

Unipolar

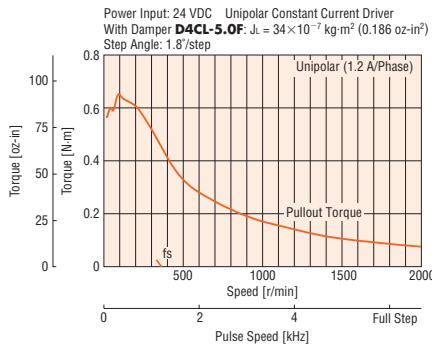

- Enter **A** (single shaft) or **B** (double shaft) in the box (□) within the model name.
Enter the encoder code (**15**, **16**, **25** or **26**) in the box (□) within the model name.

Note

- Pay attention to heat dissipation from motor as there will be a considerable amount of heat under certain conditions.
Be sure to keep the temperature of the motor case under 100°C (212°F).

20 mm
(0.79 in.)

28 mm
(1.10 in.)

35 mm
(1.38 in.)

42 mm
(1.65 in.)

50 mm
(1.97 in.)

56.4 mm
(2.22 in.)

60 mm
(2.36 in.)

85 mm
(3.35 in.)

90 mm
(3.54 in.)

Step Angle 1.8°

Motor Frame Size 56.4 mm (2.22 in.)

PK Series High-Torque Type



Specifications RoHS

Model • Single Shaft • Double Shaft • with Encoder	Connection Type	Holding Torque		Rated Current A/phase	Voltage VDC	Resistance Ω/phase	Inductance mH/phase	Rotor Inertia J		Lead Wires (Pins)	Corresponding AC/DC-Input Motor & Driver Package CMK Series
		N-m	oz-in					kg·m ²	oz-in ²		
PK264PAA PK264PBA PK264PAAR 	Bipolar (Series)	0.6	85	1.4	4.1	2.9	7.2	120×10 ⁻⁷	0.66	6	CMK264P PA/ CMK264PAPA-R
	Unipolar	0.51	72	2	2.9	1.45	1.8				
PK266PAA PK266PBA PK266PAAP 	Bipolar (Series)	1.4	198	1.4	5.6	4	11.6	290×10 ⁻⁷	1.59		CMK266P PA/ CMK266PAPA-R
	Unipolar	1.1	156	2	4	2	2.9				
PK268PAA PK268PBA PK268PAAP 	Bipolar (Series)	2.3	320	1.4	6.9	4.9	17.6	490×10 ⁻⁷	2.7		CMK268P PA/ CMK268PAPA-R
	Unipolar	1.75	240	2	4.9	2.45	4.4				

- Wires and connections → Page A-288
- Encoder specifications → Page A-17
- Enter **A** (single shaft) or **B** (double shaft) in the box (□) within the model name.
- Enter the encoder code (**15**, **16**, **25** or **26**) in the box (□) within the model name.
- Product Number Code → Page A-278

Dimensions Unit = mm (in.)

The dimensions of a motor with an encoder can be found on page A-19 or at www.orientalmotor.com.

Model	L1	L2	Mass kg (lb.)	DXF
PK264PAA	39	—	0.46	B443
PK264PBA		62		
PK266PAA	54	—	0.73	B444
PK266PBA		77		
PK268PAA	76	—	1.1	B445
PK268PBA		99		

- Lead wire and connector are not supplied with the connector-coupled motor and must be purchased separately.
- Connection cable is available as an accessory (sold separately).
- Applicable Connector
- Connector housing: 51067-0600 (MOLEX)
- Contact: 50217-9101 (MOLEX)
- Crimp tool: 57189-5000 (MOLEX)
- 57190-5000 (MOLEX)

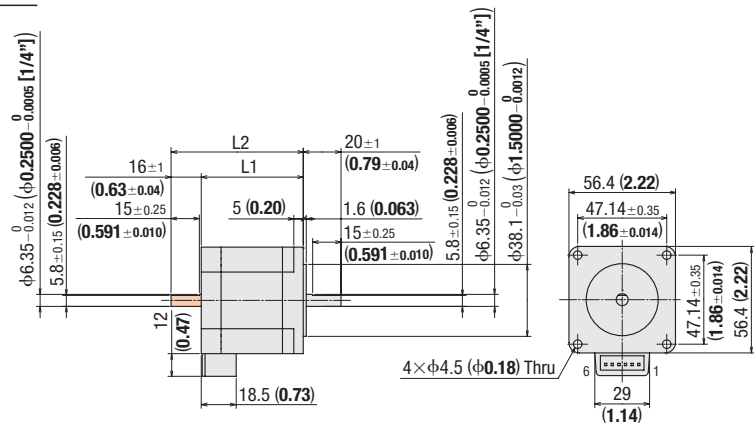

● These dimensions are for the double shaft models. For the single shaft models, ignore the orange (■) area.

Introduction
 0.36° / Geared / AR
 0.36° / Geared / AS
 AC Input Motor & Driver
 0.72° / Geared / RK
 0.9° / 1.8° / UMK
 0.36° / Geared / AR
 0.36° / Geared / ASX
 DC Input Motor & Driver
 0.36° / 0.72° / Geared / CRK
 0.9° / 1.8° / Geared / CMK
 1.8° / Geared / RBK
 Motor Only
 0.36° / PK
 0.72° / PK
 0.9° / PK
 1.8° / PK/PV
 Geared / PK
 Controllers
 SCX10 / EMP400 / SG8030J
 Accessories

Speed – Torque Characteristics

PK264P A / PK264PAAR

Bipolar (Series)

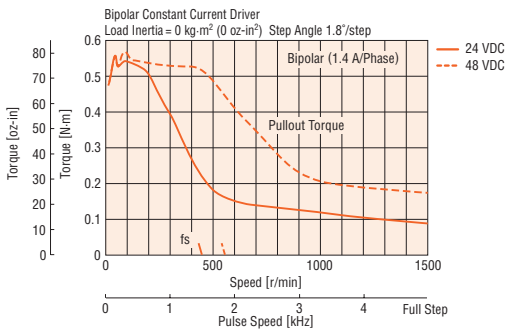

PK264P A / PK264PAAR

Unipolar

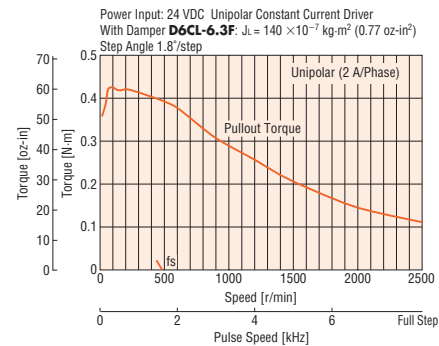

PK266P A / PK266PAAR

Bipolar (Series)

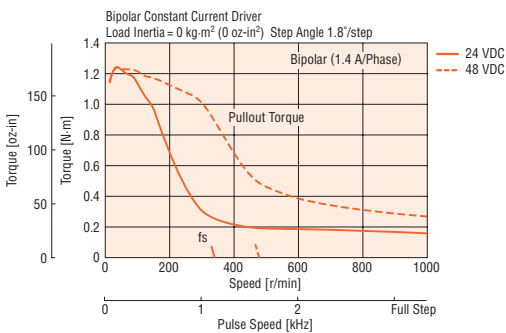

PK266P A / PK266PAAR

Unipolar

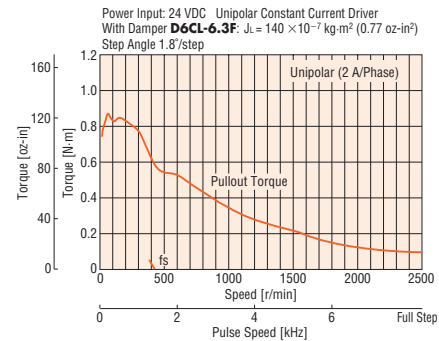

PK268P A / PK268PAAR

Bipolar (Series)

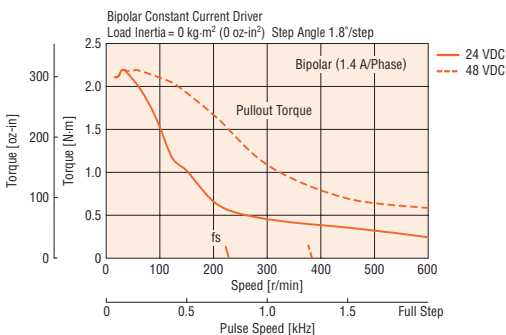

PK268P A / PK268PAAR

Unipolar

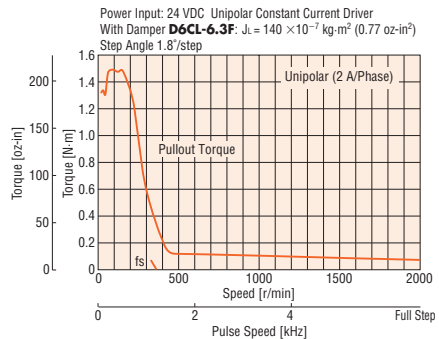

- Enter **A** (single shaft) or **B** (double shaft) in the box (□) within the model name.
- Enter the encoder code (**15**, **16**, **25** or **26**) in the box (□) within the model name.

Accessories (Sold separately)

The connection cable is available as an accessory.

- Connection cable → Page A-407

Step Angle 1.8°

Motor Frame Size 42 mm (1.65 in.)

PK Series Standard Type



Specifications (RoHS)

Model	Connection Type	Holding Torque		Rated Current	Voltage	Resistance	Inductance	Rotor Inertia J		Lead Wires	Corresponding AC/DC-Input Motor & Driver Package
		N·m	oz·in					kg·m ²	oz·in ²		
PK243-01AA PK243-01BA PK243-01AAR	Bipolar (Series)	0.2	28	0.67	5.6	8.4	10	35×10 ⁻⁷	0.191	6	UMK243□A/ CMK243□PA/ CMK243APA-R
	Unipolar	0.16	22	0.95	4	4.2	2.5				
PK243-02AA PK243-02BA	Bipolar (Series)	0.2	28	0.28	13	48	60	35×10 ⁻⁷	0.191	6	-
	Unipolar	0.16	22	0.4	9.6	24	15				
PK243-03AA PK243-03BA	Bipolar (Series)	0.2	28	0.22	17	77	84	35×10 ⁻⁷	0.191	6	-
	Unipolar	0.16	22	0.31	12	38.5	21				
PK244-01AA PK244-01BA PK244-01AAR	Bipolar (Series)	0.33	46	0.85	5.6	6.6	12.8	54×10 ⁻⁷	0.3	6	UMK244□A/ CMK244□PA/ CMK244APA-R
	Unipolar	0.26	36	1.2	4	3.3	3.2				
PK244-02AA PK244-02BA	Bipolar (Series)	0.33	46	0.57	8.6	15	26.8	54×10 ⁻⁷	0.3	6	-
	Unipolar	0.26	36	0.8	6	7.5	6.7				
PK244-03AA PK244-03BA	Bipolar (Series)	0.33	46	0.28	17	60	120	54×10 ⁻⁷	0.3	6	-
	Unipolar	0.26	36	0.4	12	30	30				
PK244-04AA PK244-04BA	Bipolar (Series)	0.33	46	0.14	34	240	428	54×10 ⁻⁷	0.3	6	-
	Unipolar	0.26	36	0.2	24	120	107				
PK245-01AA PK245-01BA PK245-01AAR	Bipolar (Series)	0.43	61	0.85	5.6	6.6	11.2	68×10 ⁻⁷	0.37	6	UMK245□A/ CMK245□PA/ CMK245APA-R
	Unipolar	0.32	45	1.2	4	3.3	2.8				
PK245-02AA PK245-02BA	Bipolar (Series)	0.43	61	0.57	8.6	15	28.4	68×10 ⁻⁷	0.37	6	-
	Unipolar	0.32	45	0.8	6	7.5	7.1				
PK245-03AA PK245-03BA	Bipolar (Series)	0.43	61	0.28	17	60	100	68×10 ⁻⁷	0.37	6	-
	Unipolar	0.32	45	0.4	12	30	25				

- Wirings and connections → Page A-288
- Encoder specifications → Page A-17
- Enter **A** (single shaft) or **B** (double shaft) in the box (□) within the model name.
- Enter the encoder code (**15**, **16**, **25** or **26**) in the box (□) within the model name.
- Product Number Code → Page A-278

Dimensions Unit = mm (in.)

The dimensions of a motor with an encoder can be found on page A-19 or at www.orientalmotor.com.

Model	L1	L2	Mass kg (lb.)	DXF
PK243-0□AA	33 (1.30)	-	0.21 (0.46)	B081U
PK243-0□BA	-	48 (1.89)	-	-
PK244-0□AA	39 (1.54)	-	0.27 (0.59)	B082U
PK244-0□BA	-	54 (2.13)	-	-
PK245-0□AA	47 (1.85)	-	0.35 (0.77)	B083U
PK245-0□BA	-	62 (2.44)	-	-

- Enter the winding specification in the box (□) within the model name.

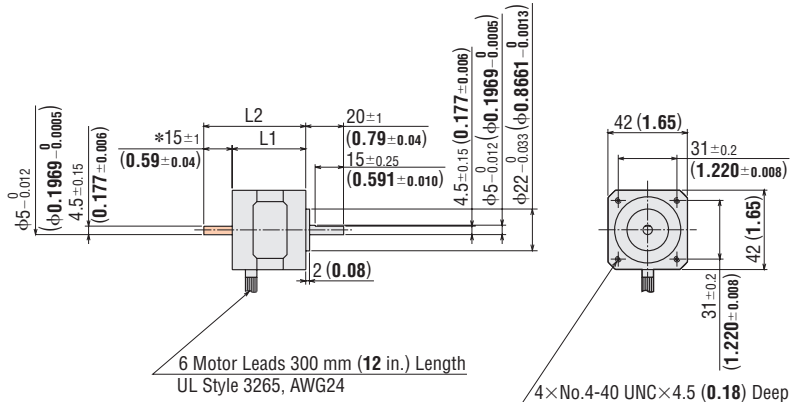

* The length of machining on the double shaft model is 15±0.25 (0.591±0.010).

- These dimensions are for the double shaft models. For the single shaft models, ignore the orange (■) area.

Introduction	AC Input Motor & Driver	Motor Only
QSTEP AR	0.36° /Geared	PK
AS	0.72° /Geared	PK
QSTEP	0.9°/1.8°	PK
UMK	0.36° /Geared	PK
AR	0.36° /Geared	PK
ASX	0.36° /Geared	PK
CRK	0.36°/0.72° /Geared	PK
CMK	0.9°/1.8° /Geared	PK
RBK	1.8° /Geared	PK
PK	0.36°	PK
PK	0.72°	PK
PK	0.9°	PK
PK/PV	1.8°	PK
Geared	Geared	PK
Controllers SCX10 /EMP400 /SG8030J	Accessories	

- 20 mm (0.79 in.)
- 28 mm (1.10 in.)
- 35 mm (1.38 in.)
- 42 mm (1.65 in.)
- 50 mm (1.97 in.)
- 56.4 mm (2.22 in.)
- 60 mm (2.36 in.)
- 85 mm (3.35 in.)
- 90 mm (3.54 in.)

Speed – Torque Characteristics

PK243-01□A/PK243-01AAR□

Bipolar (Series)

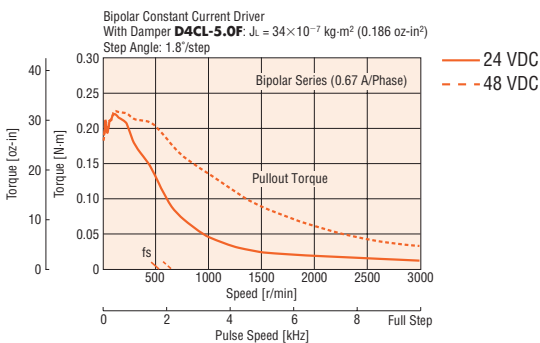

PK243-01□A/PK243-01AAR□

Unipolar

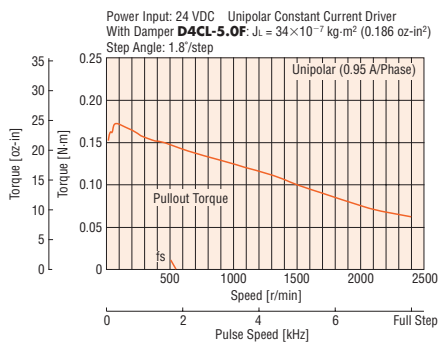

PK243-02□A

Bipolar (Series)

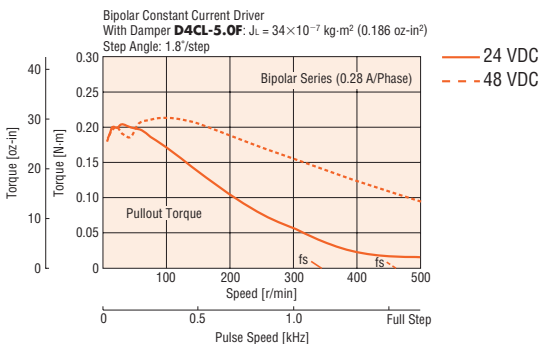

PK243-02□A

Unipolar

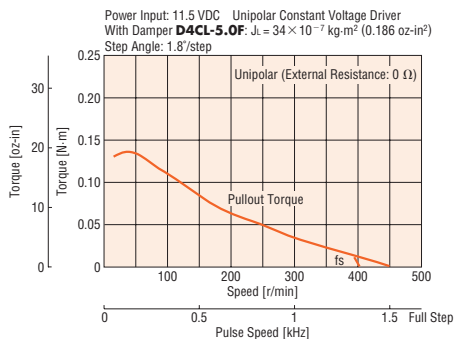

PK243-03□A

Bipolar (Series)

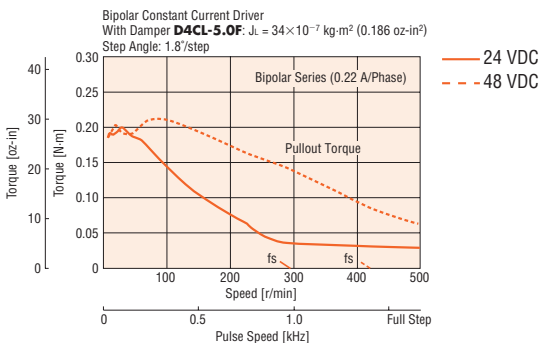

PK243-03□A

Unipolar

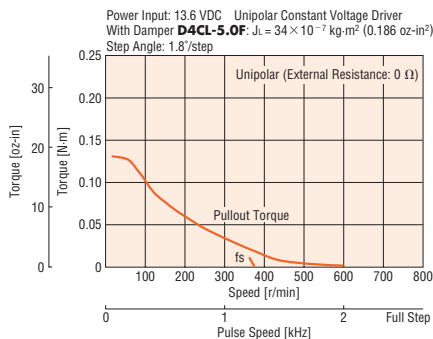

- Enter **A** (single shaft) or **B** (double shaft) in the box (□) within the model name.
- Enter the encoder code (**15**, **16**, **25** or **26**) in the box (□) within the model name.

Note

- Pay attention to heat dissipation from motor as there will be a considerable amount of heat under certain conditions.
- Be sure to keep the temperature of the motor case under 100°C (212°F).

PK244-01□A/PK244-01AAR□

Bipolar (Series)

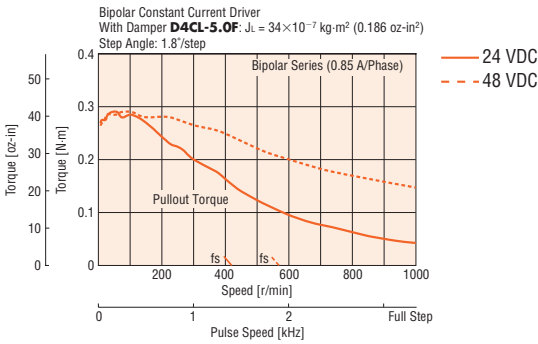

PK244-02□A

Bipolar (Series)

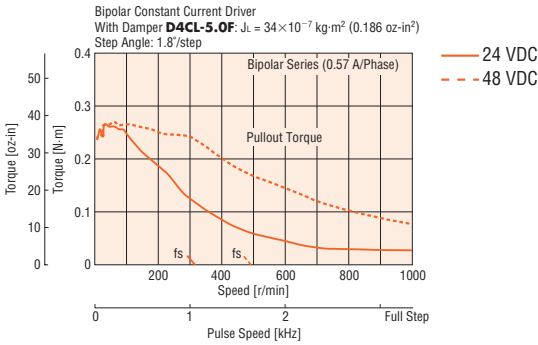

PK244-01□A/PK244-01AAR□

Unipolar

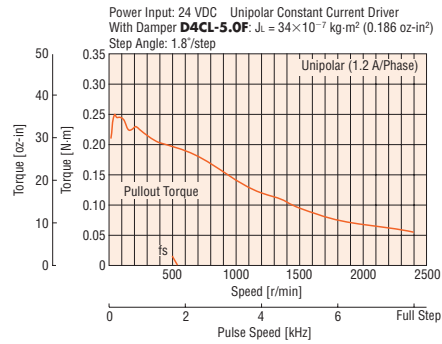

PK244-02□A

Unipolar

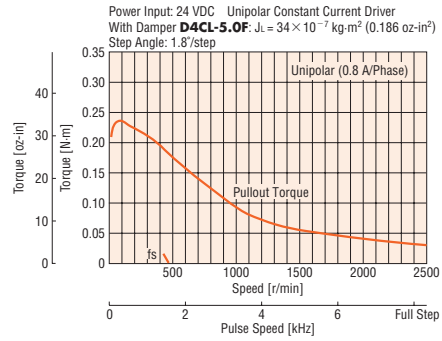

PK244-03□A

Unipolar

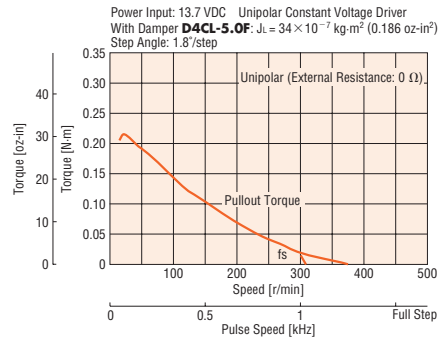

PK244-04□A

Unipolar

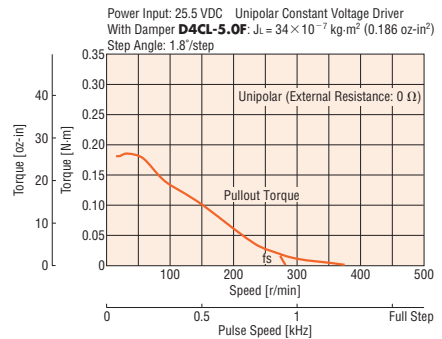

- Enter **A** (single shaft) or **B** (double shaft) in the box (□) within the model name.
- Enter the encoder code (**15**, **16**, **25** or **26**) in the box (□) within the model name.

Note

- Pay attention to heat dissipation from motor as there will be a considerable amount of heat under certain conditions. Be sure to keep the temperature of the motor case under 100°C (212°F).

Introduction	
AR	AC Input Motor & Driver
AS	0.36° / Geared
ASX	0.72° / Geared
CRK	0.9°/1.8°
CMK	0.36° / Geared
RBK	0.36°/0.72° / Geared
PK	0.9°/1.8°
PK	1.8° / Geared
PK	0.36°
PK	0.72°
PK	0.9°
PK/PV	1.8°
PK	Geared
SCX10 / EMP400 / SG8030J	Motor Only
	Controllers
	Accessories

Speed – Torque Characteristics

PK245-01 A/PK245-01AAR

Bipolar (Series)

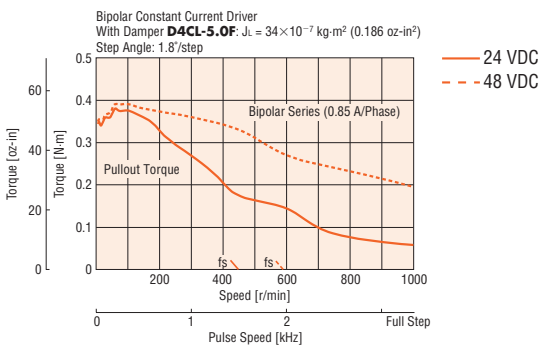

PK245-01 A/PK245-01AAR

Unipolar

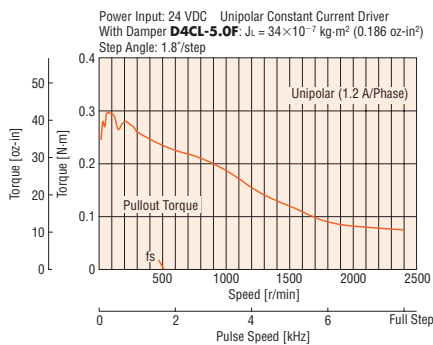

PK245-02 A

Bipolar (Series)

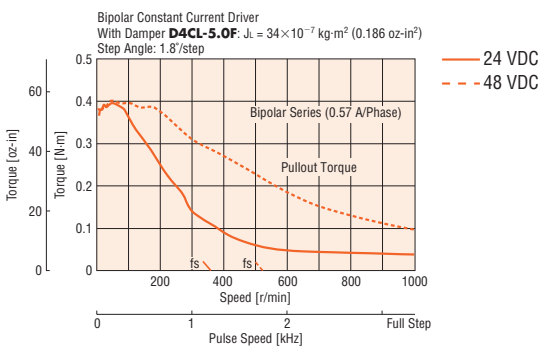

PK245-02 A

Unipolar

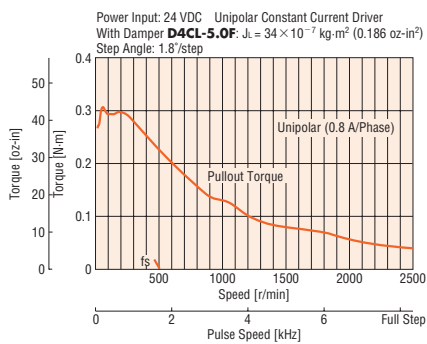

PK245-03 A

Unipolar

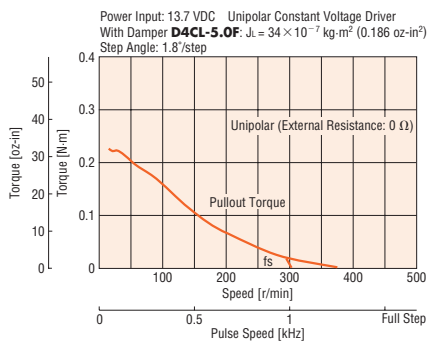

- Enter **A** (single shaft) or **B** (double shaft) in the box (□) within the model name.
- Enter the encoder code (**15**, **16**, **25** or **26**) in the box (■) within the model name.

Note

- Pay attention to heat dissipation from motor as there will be a considerable amount of heat under certain conditions. Be sure to keep the temperature of the motor case under 100°C (212°F).

Step Angle 1.8°

Motor Frame Size 50 mm (1.97 in.)

PK Series Standard Type

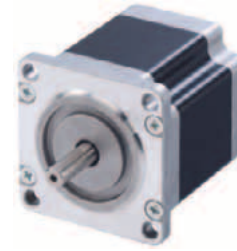

Specifications RoHS

Model • Single Shaft • Double Shaft • with Encoder	Connection Type	Holding Torque		Rated Current A/phase	Voltage VDC	Resistance Ω/phase	Inductance mH/phase	Rotor Inertia J		Lead Wires (Pins)	Corresponding DC-Input Motor & Driver Package CMK Series
		N-m	oz-in					kg-m ²	oz-in ²		
PK256-02A PK256-02B PK256-02AR 	Bipolar (Series)	0.84	119	1.4	4.2	3	5.6	230×10 ⁻⁷	1.26	6	CMK256□P/ CMK256AP-R
	Unipolar	0.6	85	2	3	1.5	1.4				
PK258-02A PK258-02B PK258-02AR 	Bipolar (Series)	1.56	220	1.4	6.7	4.8	11.5	420×10 ⁻⁷	2.3	6	CMK258□P/ CMK258AP-R
	Unipolar	1.2	170	2	4.8	2.4	2.87				

- Wirings and connections → Page A-288
- Encoder specifications → Page A-17
- Enter **A** (single shaft) or **B** (double shaft) in the box (□) within the model name.
Enter the encoder code (**15**, **16**, **25** or **26**) in the box (▢) within the model name.
- Product Number Code → Page A-278

Dimensions Unit = mm (in.)

The dimensions of a motor with an encoder can be found on page A-19 or at www.orientalmotor.com.

Model	L1	L2	Mass kg (lb.)	DXF
PK256-02A PK256-02B	51.5 (2.03)	— 67.5 (2.66)	0.53 (1.17)	B333
PK258-02A PK258-02B	81 (3.19)	— 97 (3.82)	0.89 (1.96)	B334

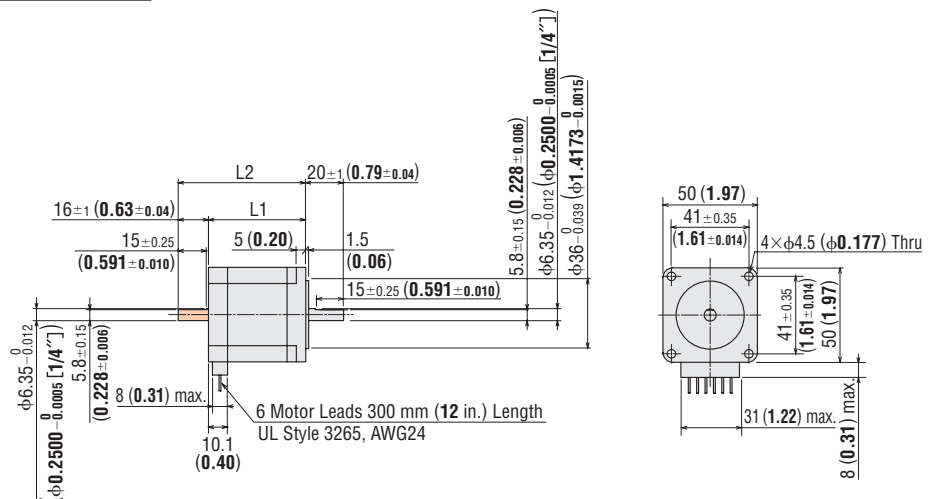

• These dimensions are for the double shaft models. For the single shaft models, ignore the orange (▢) area.

Introduction	AC Input Motor & Driver	DC Input Motor & Driver	Motor Only
AR	AS	ASX	PK
0.36° / Geared	0.36° / Geared	0.36° / Geared	0.36°
0.72° / Geared	0.72° / Geared	0.36° / Geared	0.72°
RK	UMK	CRK	PK
0.9° / 1.8°	0.9° / 1.8°	0.36° / Geared	0.9°
AR	AS	CMK	PK/PV
0.36° / Geared	0.36° / Geared	0.9° / 1.8° / Geared	1.8°
0.72° / Geared	0.72° / Geared	1.8° / Geared	Geared
0.9° / 1.8°	0.9° / 1.8°	PK	PK
0.36° / Geared	0.36° / Geared	PK	Geared
0.72° / Geared	0.72° / Geared	PK	Controllers
0.9° / 1.8°	0.9° / 1.8°	PK	SCX10
1.8° / Geared	1.8° / Geared	PK	EMP400
Geared	Geared	PK	/SG8030J
Accessories	Accessories	PK	Accessories

Speed – Torque Characteristics

PK256-02□/PK256-02AR□

Bipolar (Series)

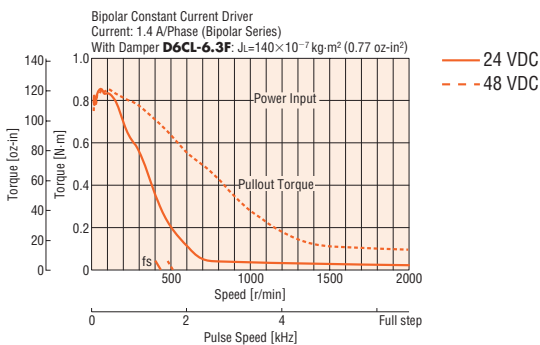

PK256-02□/PK256-02AR□

Unipolar

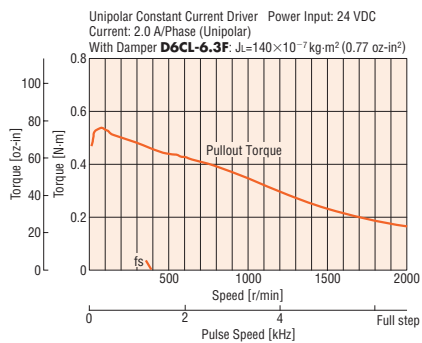

PK258-02□/PK258-02AR□

Bipolar (Series)

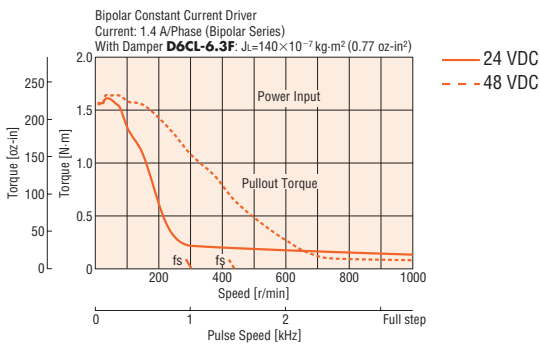

PK258-02□/PK258-02AR□

Unipolar

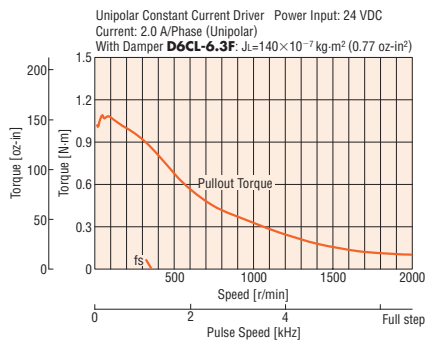

- Enter **A** (single shaft) or **B** (double shaft) in the box (□) within the model name.
Enter the encoder code (**15**, **16**, **25** or **26**) in the box (□) within the model name.

Note

- Pay attention to heat dissipation from motor as there will be a considerable amount of heat under certain conditions.
Be sure to keep the temperature of the motor case under 100°C (212°F).

□ 20 mm
(0.79 in.)

□ 28 mm
(1.10 in.)

□ 35 mm
(1.38 in.)

□ 42 mm
(1.65 in.)

□ 50 mm
(1.97 in.)

□ 56.4 mm
(2.22 in.)

□ 60 mm
(2.36 in.)

□ 85 mm
(3.35 in.)

□ 90 mm
(3.54 in.)

Step Angle 1.8°

Motor Frame Size 56.4 mm (2.22 in.)

PK Series Standard Type



Specifications RoHS

Model • Single Shaft • Double Shaft • with Encoder	Connection Type	Holding Torque		Rated Current A/phase	Voltage VDC	Resistance Ω/phase	Inductance mH/phase	Rotor Inertia J		Lead Wires	Corresponding AC/DC-Input Motor & Driver Package UMK/CMK Series
		N-m	oz-in					kg-m ²	oz-in ²		
PK264-01A PK264-01B	Bipolar (Series) Unipolar	0.48 0.39	68 55	0.71 1	8.1 5.7	11.4 5.7	21.6 5.4	120×10 ⁻⁷	0.66	6	—
PK264-02A PK264-02B PK264-02AR □	Bipolar (Series) Unipolar	0.48 0.39	68 55	1.4 2	3.9 2.8	2.8 1.4	5.6 1.4	120×10 ⁻⁷	0.66	6	UMK264 □A/ CMK264 □P/ CMK264AP-R □
PK264-03A PK264-03B	Bipolar (Series) Unipolar	0.48 0.39	68 55	2.1 3	2.6 1.9	1.26 0.63	2.4 0.6	120×10 ⁻⁷	0.66	6	—
PK264-E2.0A PK264-E2.0B	Bipolar (Parallel) Bipolar (Series) Unipolar	0.48 0.48 0.39	68 68 55	2.8 1.4 2	1.96 3.9 2.8	0.7 2.8 1.4	1.4 5.6 1.4	120×10 ⁻⁷	0.66	8	—
PK266-01A PK266-01B	Bipolar (Series) Unipolar	1.17 0.9	166 127	0.71 1	11 7.4	14.8 7.4	40 10	300×10 ⁻⁷	1.64	6	—
PK266-02A PK266-02B PK266-02AR □	Bipolar (Series) Unipolar	1.17 0.9	166 127	1.4 2	5 3.6	3.6 1.8	10 2.5	300×10 ⁻⁷	1.64	6	UMK266 □A/ CMK266 □P/ CMK266AP-R □
PK266-03A PK266-03B	Bipolar (Series) Unipolar	1.17 0.9	166 127	2.1 3	3.2 2.3	1.5 0.75	4.4 1.1	300×10 ⁻⁷	1.64	6	—
PK266-E2.0A PK266-E2.0B	Bipolar (Parallel) Bipolar (Series) Unipolar	1.17 1.17 0.9	166 166 127	2.8 1.4 2	2.52 5 3.6	0.9 3.6 1.8	2.5 10 2.5	300×10 ⁻⁷	1.64	8	—
PK268-01A PK268-01B	Bipolar (Series) Unipolar	1.75 1.35	240 191	0.71 1	12 8.6	17.2 8.6	56 14	480×10 ⁻⁷	2.6	6	—
PK268-02A PK268-02B PK268-02AR □	Bipolar (Series) Unipolar	1.75 1.35	240 191	1.4 2	6.3 4.5	4.5 2.25	14.4 3.6	480×10 ⁻⁷	2.6	6	UMK268 □A/ CMK268 □P/ CMK268AP-R □
PK268-03A PK268-03B	Bipolar (Series) Unipolar	1.75 1.35	240 191	2.1 3	4.2 3	2 1	6.4 1.6	480×10 ⁻⁷	2.6	6	—
PK268-E2.0A PK268-E2.0B	Bipolar (Parallel) Bipolar (Series) Unipolar	1.75 1.75 1.35	240 240 191	2.8 1.4 2	3.16 6.3 4.5	1.13 4.5 2.25	3.6 14.4 3.6	480×10 ⁻⁷	2.6	8	—

- Wirings and connections → Page A-288
- Encoder specifications → Page A-17
- Enter **A** (single shaft) or **B** (double shaft) in the box (□) within the model name.
- Enter the encoder code (**15**, **16**, **25** or **26**) in the box (□) within the model name.
- Product Number Code → Page A-278

Dimensions Unit = mm (in.)

The dimensions of a motor with an encoder can be found on page A-19 or at www.orientalmotor.com.

Model	L1	L2	Mass kg (lb.)	DXF
PK264-0 □A PK264-E2.0A	39 (1.54)	—	0.45 (0.99)	B084
PK264-0 □B PK264-E2.0B	—	55 (2.17)	—	—
PK266-0 □A PK266-E2.0A	54 (2.13)	—	0.7 (1.54)	B085
PK266-0 □B PK266-E2.0B	—	70 (2.76)	—	—
PK268-0 □A PK268-E2.0A	76 (2.99)	—	1 (2.2)	B086
PK268-0 □B PK268-E2.0B	—	92 (3.62)	—	—

- Enter the winding specification in the box () within the model name.
- These dimensions are for the double shaft models. For the single shaft models, ignore the orange () area.

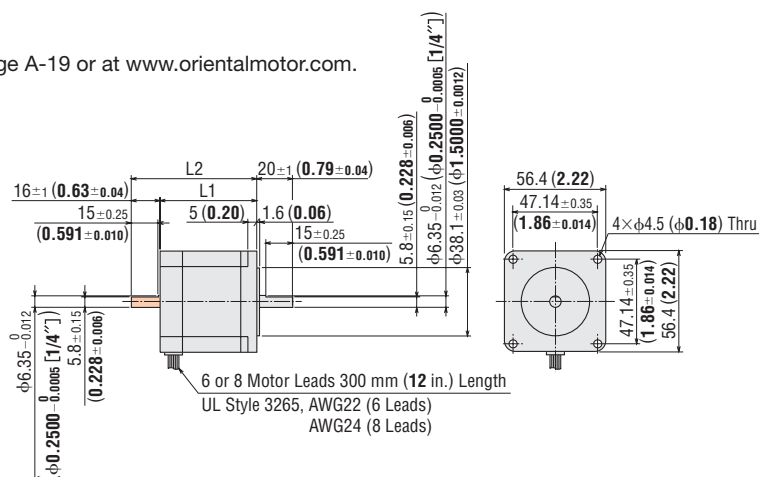

Introduction

AC Input Motor & Driver

0.36° / Geared / 0.72° / Geared

0.9°/1.8°

0.36° / Geared / 0.72° / Geared

0.36° / Geared / 0.72° / Geared

0.9°/1.8° / Geared

1.8° / Geared

0.36° / Geared

0.72° / Geared

0.9° / Geared

1.8° / Geared

Geared

Controllers
SCM10
EMP400
/SG8030J

Accessories

Speed – Torque Characteristics

PK264-01

Bipolar (Series)

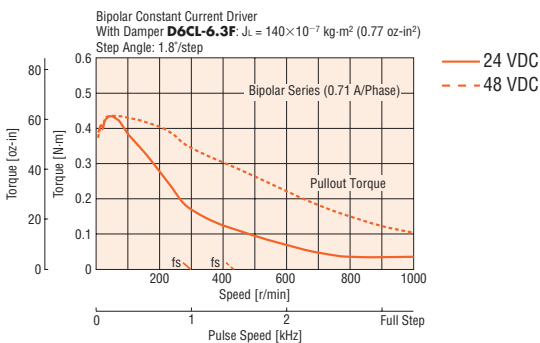

PK264-01

Unipolar

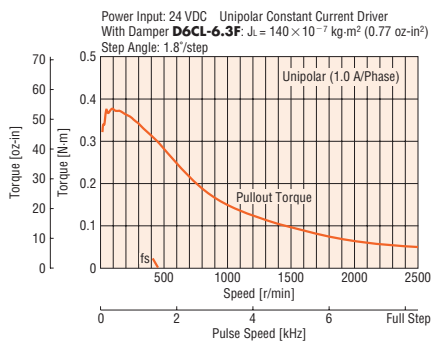

PK264-02 /PK264-02AR

Bipolar (Series)

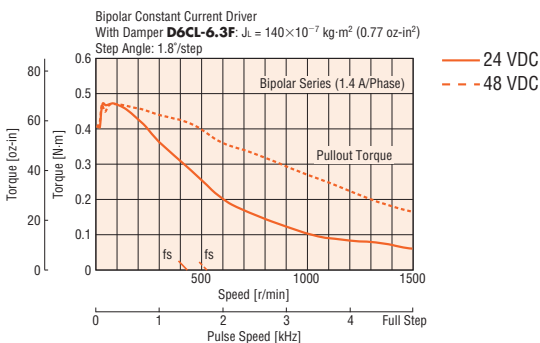

PK264-02 /PK264-02AR

Unipolar

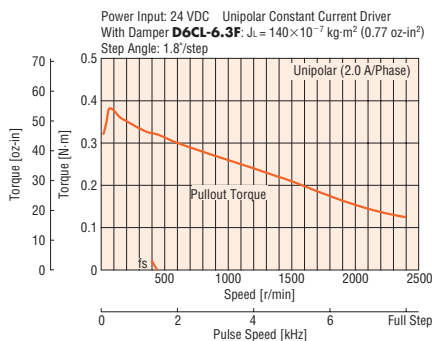

PK264-03

Bipolar (Series)

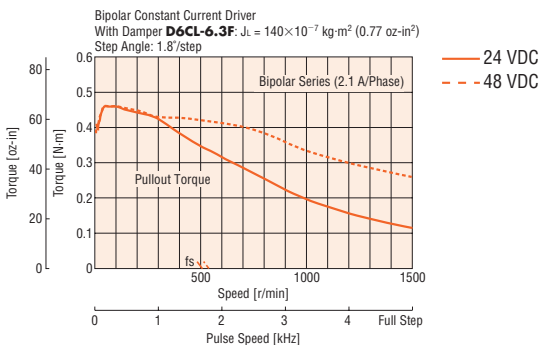

PK264-03

Unipolar

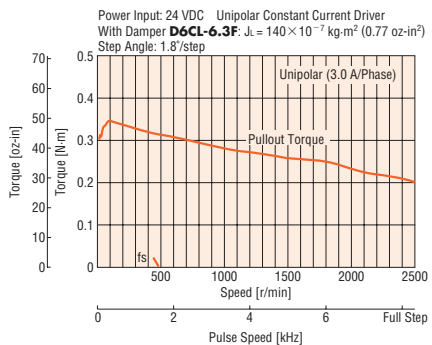

PK264-E2.0

Bipolar (Parallel)

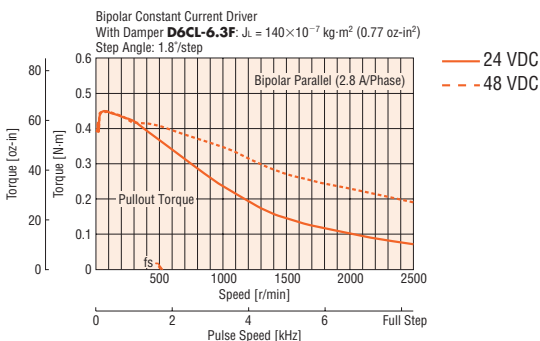

PK264-E2.0

Bipolar (Series)

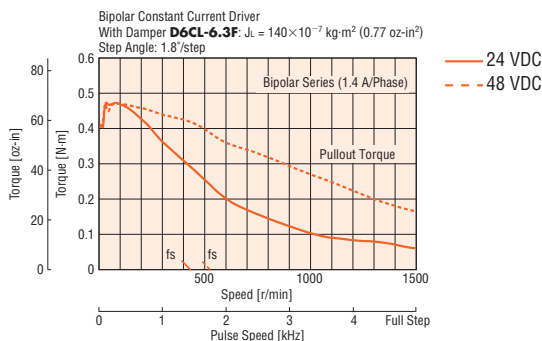

- Enter **A** (single shaft) or **B** (double shaft) in the box (□) within the model name.
Enter the encoder code (**15**, **16**, **25** or **26**) in the box (▣) within the model name.

Note

- Pay attention to heat dissipation from motor as there will be a considerable amount of heat under certain conditions.
Be sure to keep the temperature of the motor case under 100°C (212°F).

PK266-01

Bipolar (Series)

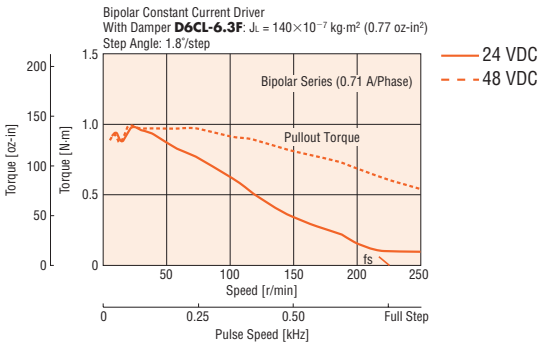

PK266-02 /PK266-02AR

Bipolar (Series)

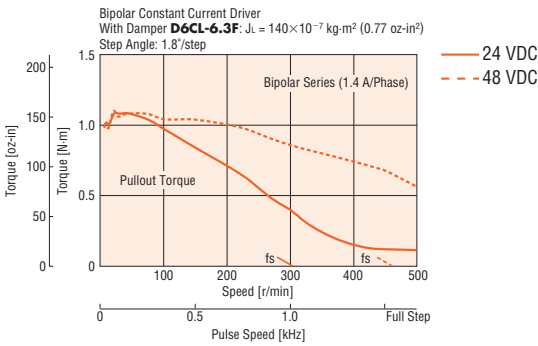

PK266-03

Bipolar (Series)

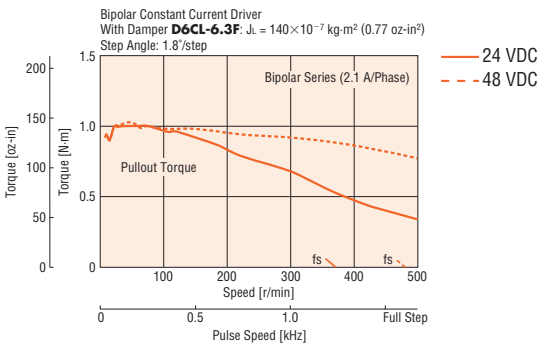

PK266-E2.0

Bipolar (Parallel)

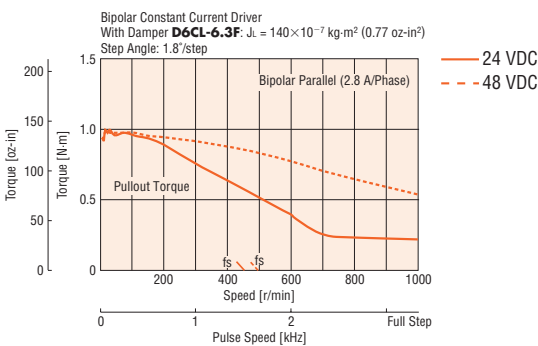

PK266-01

Unipolar

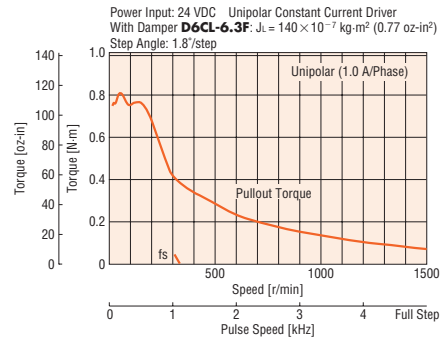

PK266-02 /PK266-02AR

Unipolar

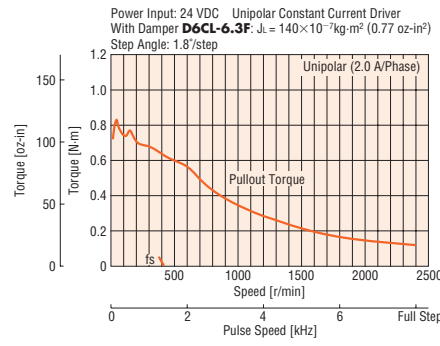

PK266-03

Unipolar

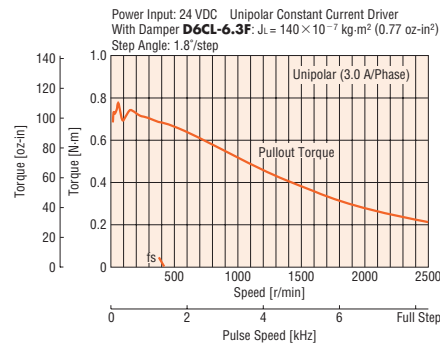

PK266-E2.0

Bipolar (Series)

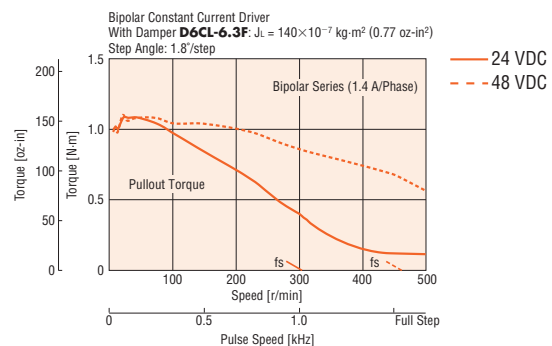

- Enter **A** (single shaft) or **B** (double shaft) in the box (□) within the model name.
- Enter the encoder code (**15**, **16**, **25** or **26**) in the box (▣) within the model name.

Note

- Pay attention to heat dissipation from motor as there will be a considerable amount of heat under certain conditions. Be sure to keep the temperature of the motor case under 100°C (212°F).

Introduction	AC Input Motor & Driver	Motor Only
AR	0.36° / Geared	PK
AS	0.36° / Geared	PK
RK	0.72° / Geared	PK
UMK	0.9°/1.8°	PK
AR	0.36° / Geared	PK/PV
ASX	0.36° / Geared	PK
CRK	0.36°/0.72° / Geared	PK
CMK	0.9°/1.8° / Geared	PK
RBK	1.8° / Geared	PK
PK	0.36°	PK
PK	0.72°	PK
PK	0.9°	PK
PK/PV	1.8°	PK
PK	Geared	PK
SCX10 / EMP400 / SG80301	Controllers	Accessories

Speed – Torque Characteristics

PK268-01

Bipolar (Series)

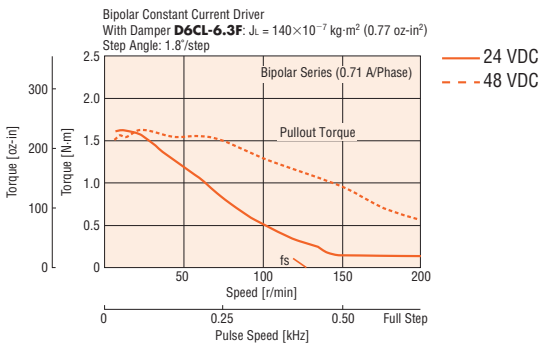

PK268-01

Unipolar

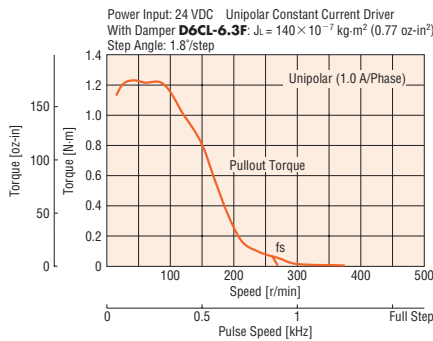

PK268-02 /PK268-02AR

Bipolar (Series)

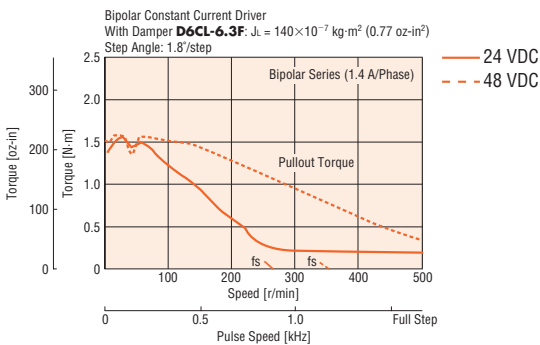

PK268-02 /PK268-02AR

Unipolar

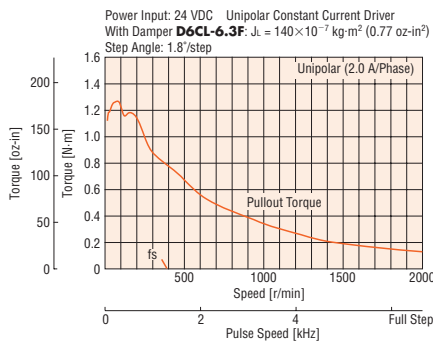

PK268-03

Bipolar (Series)

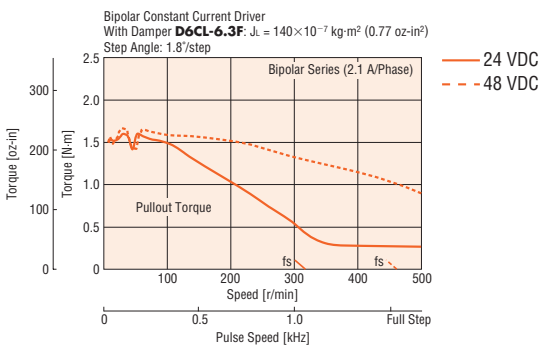

PK268-03

Unipolar

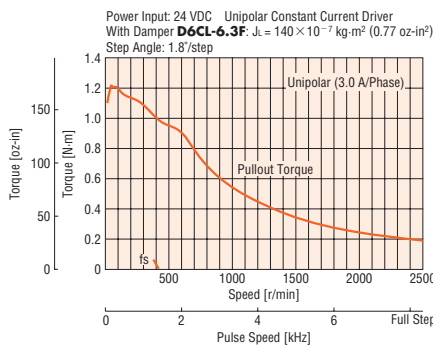

PK268-E2.0

Bipolar (Parallel)

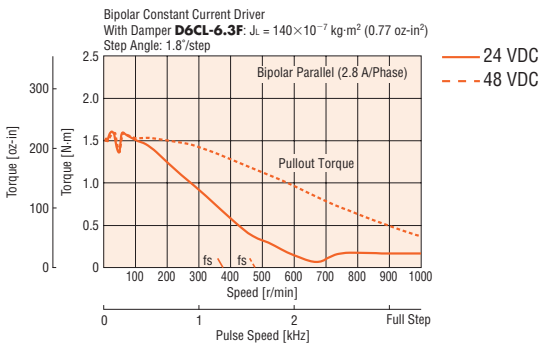

PK268-E2.0

Bipolar (Series)

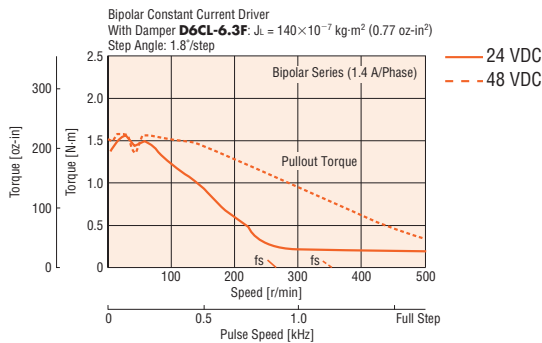

● Enter **A** (single shaft) or **B** (double shaft) in the box () within the model name.
Enter the encoder code (**15**, **16**, **25** or **26**) in the box () within the model name.

Note

● Pay attention to heat dissipation from motor as there will be a considerable amount of heat under certain conditions.
Be sure to keep the temperature of the motor case under 100°C (212°F).

20 mm
(0.79 in.)

28 mm
(1.10 in.)

35 mm
(1.38 in.)

42 mm
(1.65 in.)

50 mm
(1.97 in.)

56.4 mm
(2.22 in.)

60 mm
(2.36 in.)

85 mm
(3.35 in.)

90 mm
(3.54 in.)

Speed – Torque Characteristics

PK264DAT

Bipolar

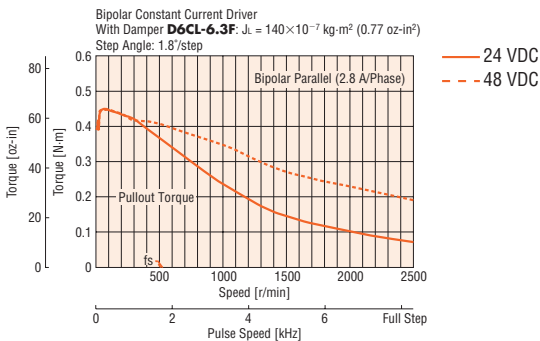

PK266DAT

Bipolar

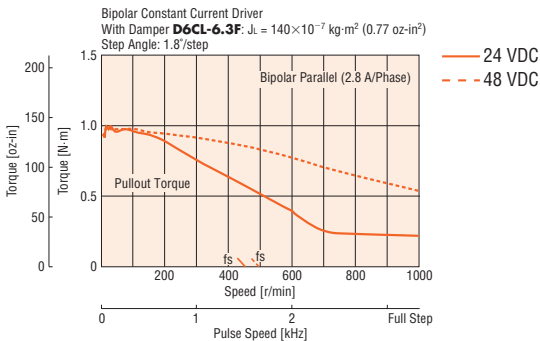

PK268DAT

Bipolar

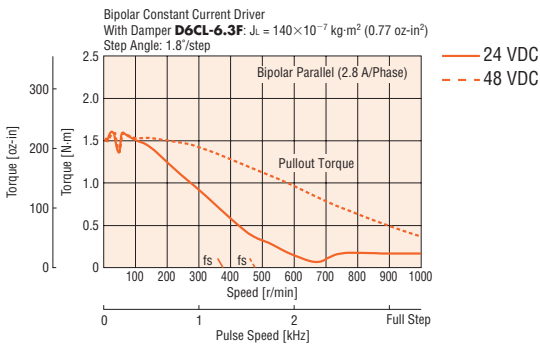

Note

- Pay attention to heat dissipation from motor as there will be a considerable amount of heat under certain conditions. Be sure to keep the temperature of the motor case under 100°C (212°F).

20 mm
(0.79 in.)

28 mm
(1.10 in.)

35 mm
(1.38 in.)

42 mm
(1.65 in.)

50 mm
(1.97 in.)

56.4 mm
(2.22 in.)

60 mm
(2.36 in.)

85 mm
(3.35 in.)

90 mm
(3.54 in.)

Step Angle 1.8°

Motor Frame Size 60 mm (2.36 in.)

PV Series

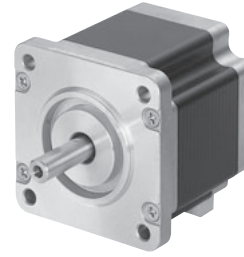

Specifications (RoHS)

Model • Single Shaft • Double Shaft	Connection Type	Holding Torque		Rated Current A/phase	Voltage VDC	Resistance Ω/phase	Inductance mH/phase	Rotor Inertia J		Lead Wires
		N-m	oz-in					kg-m ²	oz-in ²	
PV264-D2.8AA PV264-D2.8BA	Bipolar	1.06	150	2.8	2.1	0.73	1.8	280×10 ⁻⁷	1.53	4
PV264-02AA PV264-02BA	Bipolar (Series)	1.06	150	1.4	4.1	2.92	7.2	280×10 ⁻⁷	1.53	6
	Unipolar	0.75	106	2	2.9	1.46	1.8			
PV266-D2.8AA PV266-D2.8BA	Bipolar	1.75	240	2.8	2.8	1	3.05	450×10 ⁻⁷	2.5	4
PV266-02AA PV266-02BA	Bipolar (Series)	1.75	240	1.4	5.6	4	12.2	450×10 ⁻⁷	2.5	6
	Unipolar	1.35	191	2	4	2	3.05			
PV267-D2.8AA PV267-D2.8BA	Bipolar	2.2	310	2.8	3.4	1.2	3.54	570×10 ⁻⁷	3.1	4
PV267-02AA PV267-02BA	Bipolar (Series)	2.2	310	1.4	6.7	4.8	14.2	570×10 ⁻⁷	3.1	6
	Unipolar	1.7	240	2	4.8	2.4	3.54			
PV269-D2.8AA PV269-D2.8BA	Bipolar	3.1	440	2.8	4.2	1.49	5.7	900×10 ⁻⁷	4.9	4
PV269-02AA PV269-02BA	Bipolar (Series)	3.1	440	1.4	8.3	5.96	22.8	900×10 ⁻⁷	4.9	6
	Unipolar	2.2	310	2	6	2.98	5.7			

● Wirings and connections → Page A-288

Dimensions Unit = mm (in.)

● PV264, PV266, PV267

Model	L1	L2	Mass kg (lb.)	DXF
PV264-D2.8AA PV264-02AA	43.5 (1.71)	—	0.6 (1.3)	B279U
PV264-D2.8BA PV264-02BA		59.5 (2.34)		
PV266-D2.8AA PV266-02AA	54 (2.13)	—	0.83 (1.8)	B232U
PV266-D2.8BA PV266-02BA		70 (2.76)		
PV267-D2.8AA PV267-02AA	65 (2.56)	—	1.02 (2.2)	B813U
PV267-D2.8BA PV267-02BA		81 (3.19)		

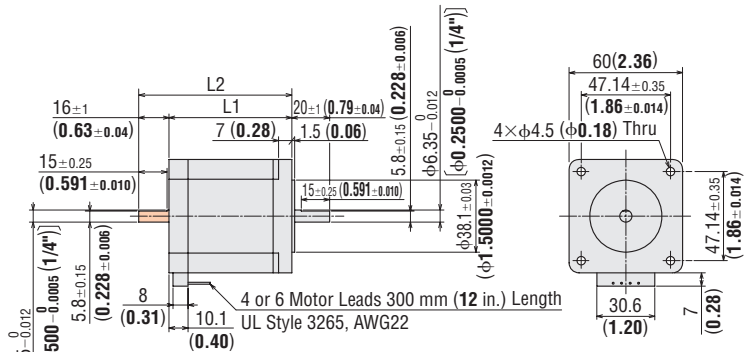

● PV269

Model	Mass kg (lb.)	DXF
PV269-D2.8AA PV269-02AA	1.43 (3.1)	B814U
PV269-D2.8BA PV269-02BA		

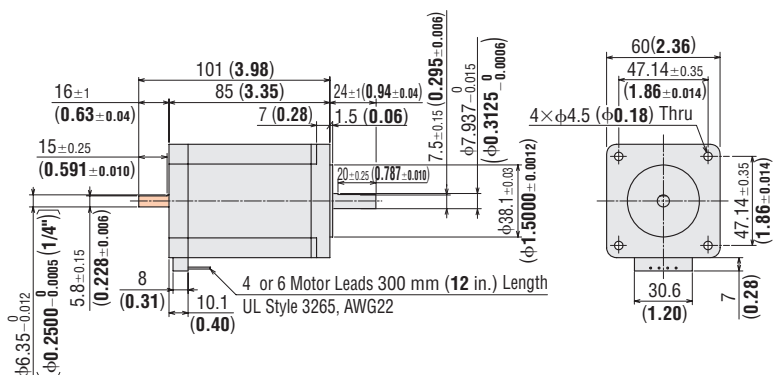

● These dimensions are for the double shaft models. For the single shaft models, ignore the orange () areas.

Introduction	AC Input Motor & Driver	Motor Only
AR	0.36° / Geared	1.8° / Geared
AS	0.72° / Geared	0.36°
UMK	0.9°/1.8°	0.72°
AR	0.36° / Geared	0.9°
ASX	0.36° / Geared	1.8° / Geared
CRK	0.36°/0.72° / Geared	0.36°
CMK	0.9°/1.8° / Geared	0.72°
RBK	1.8° / Geared	0.9°
PK	0.36°	1.8° / PV
PK	0.72°	Geared
PK	0.9°	PK
PK/PV	1.8°	Controllers SCX10 EMP400 /SG80301
PK	Geared	Accessories

Speed – Torque Characteristics

PV264-D2.8□A

Bipolar

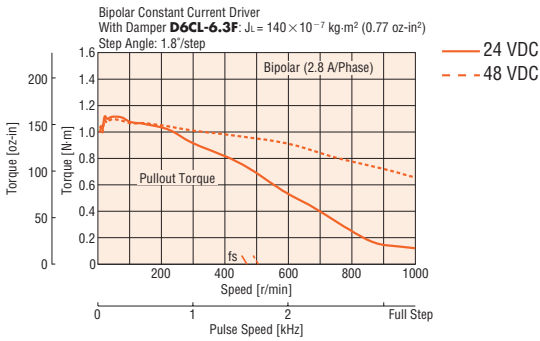

PV266-D2.8□A

Bipolar

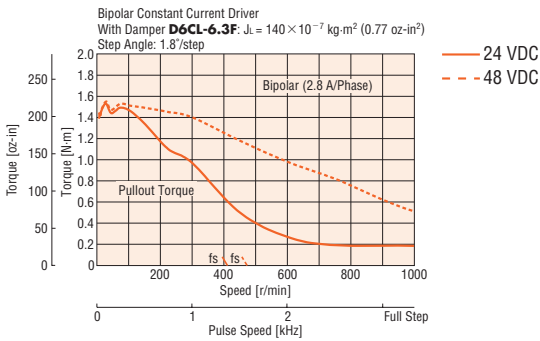

PV267-D2.8□A

Bipolar

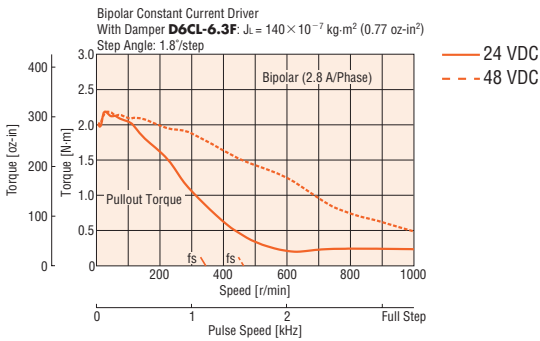

PV269-D2.8□A

Bipolar

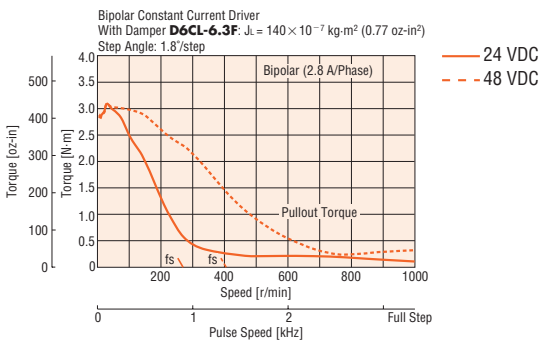

● Enter **A** (single shaft) or **B** (double shaft) in the box (□) within the model name.

Note

● Pay attention to heat dissipation from motor as there will be a considerable amount of heat under certain conditions.
Be sure to keep the temperature of the motor case under 100°C (212°F).

PV264-02□A Bipolar (Series)

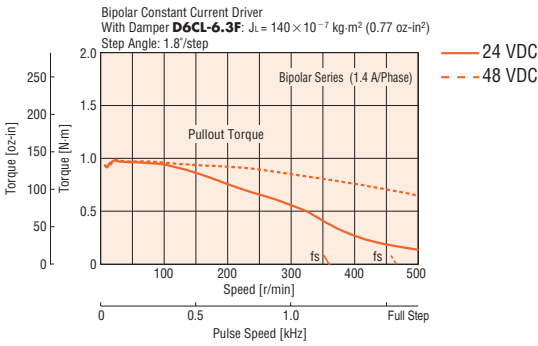

PV266-02□A Bipolar (Series)

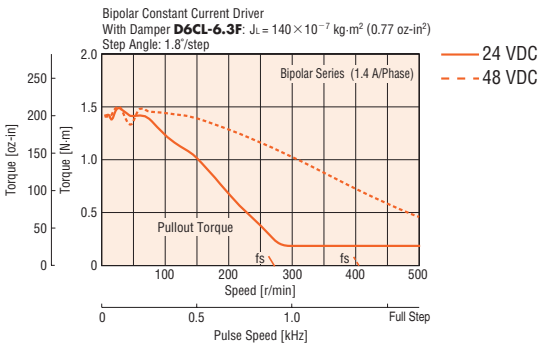

PV267-02□A Bipolar (Series)

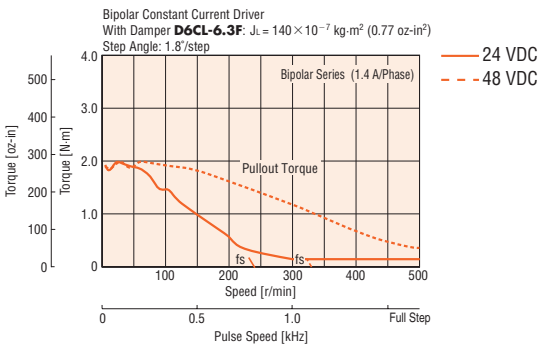

PV269-02□A Bipolar (Series)

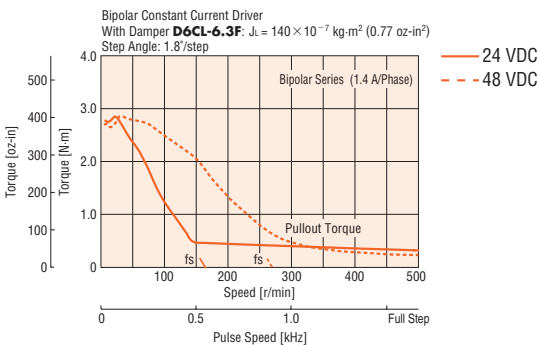

PV264-02□A Unipolar

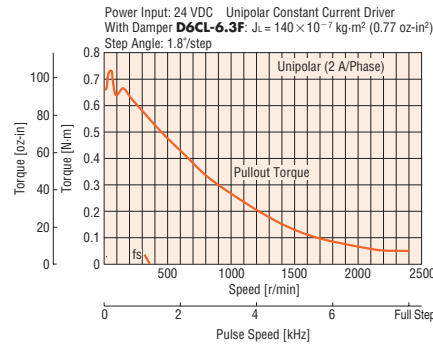

PV266-02□A Unipolar

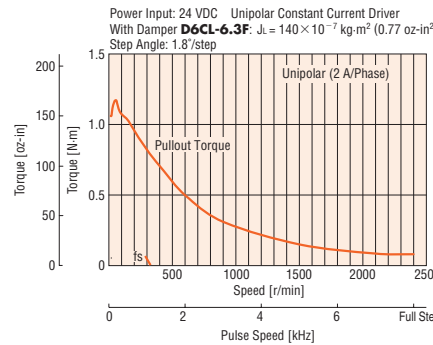

PV267-02□A Unipolar

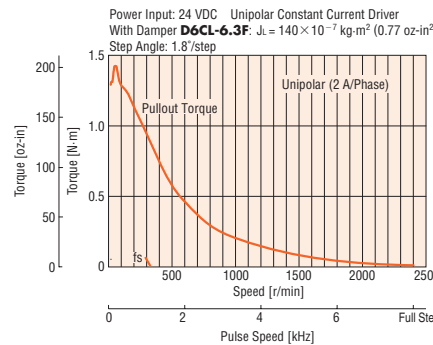

PV269-02□A Unipolar

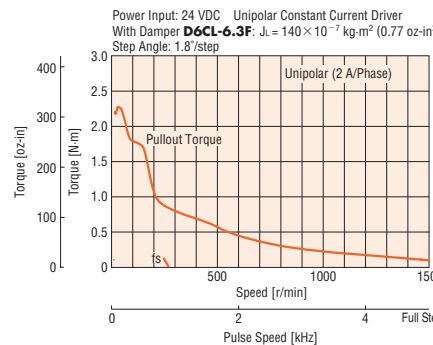

● Enter **A** (single shaft) or **B** (double shaft) in the box (□) within the model name.

Note

● Pay attention to heat dissipation from motor as there will be a considerable amount of heat under certain conditions.
Be sure to keep the temperature of the motor case under 100°C (212°F).

Introduction	AC Input Motor & Driver	0.9°/1.8°	0.36°/Geared	0.72°/Geared	0.9°/1.8°/Geared	1.8°/Geared	0.36°	0.72°	0.9°	1.8°	Motor Only	1.8°	Geared	Controllers SCX10 EMP400 /SG8030J	Accessories
AR	AS	UMK	AR	ASX	CRK	CMK	PK	PK	PK	PK	PK/PV	PK	PK		

Step Angle 1.8°

Motor Frame Size 85 mm (3.35 in.)

PK Series Standard Type



- 20 mm (0.79 in.)
- 28 mm (1.10 in.)
- 35 mm (1.38 in.)
- 42 mm (1.65 in.)
- 50 mm (1.97 in.)
- 56.4 mm (2.22 in.)
- 60 mm (2.36 in.)
- 85 mm (3.35 in.)
- 90 mm (3.54 in.)

Specifications (RoHS)

Model • Single Shaft • Double Shaft	Connection Type	Holding Torque		Rated Current A/phase	Voltage VDC	Resistance Ω/phase	Inductance mH/phase	Rotor Inertia J		Lead Wires
		N-m	oz-in					kg-m ²	oz-in ²	
PK296-01AA PK296-01BA	Bipolar (Series)	3.1	440	1.4	6.2	4.4	30.8	1400×10 ⁻⁷	7.7	6
	Unipolar	2.2	310	2	4.4	2.2	7.7			
PK296-02AA PK296-02BA	Bipolar (Series)	3.1	440	2.1	4.2	2	14	1400×10 ⁻⁷	7.7	6
	Unipolar	2.2	310	3	3	1	3.5			
PK296-03AA PK296-03BA	Bipolar (Series)	3.1	440	3.18	2.8	0.96	6	1400×10 ⁻⁷	7.7	6
	Unipolar	2.2	310	4.5	2	0.48	1.5			
PK296-F4.5A PK296-F4.5B	Bipolar (Parallel)	3.1	440	6.3	1.4	0.24	1.5	1400×10 ⁻⁷	7.7	8
	Bipolar (Series)	3.1	440	3.18	2.8	0.96	6			
	Unipolar	2.2	310	4.5	2	0.48	1.5			
PK299-01AA PK299-01BA	Bipolar (Series)	6.2	880	1.4	9	6.4	56	2700×10 ⁻⁷	14.8	6
	Unipolar	4.4	620	2	6.4	3.2	14			
PK299-02AA PK299-02BA	Bipolar (Series)	6.2	880	2.1	6	3	24	2700×10 ⁻⁷	14.8	6
	Unipolar	4.4	620	3	4.2	1.5	6			
PK299-03AA PK299-03BA	Bipolar (Series)	6.2	880	3.18	3.9	1.32	10	2700×10 ⁻⁷	14.8	6
	Unipolar	4.4	620	4.5	2.8	0.66	2.5			
PK299-F4.5A PK299-F4.5B	Bipolar (Parallel)	6.2	880	6.3	1.9	0.33	2.5	2700×10 ⁻⁷	14.8	8
	Bipolar (Series)	6.2	880	3.18	3.9	1.32	10			
	Unipolar	4.4	620	4.5	2.8	0.66	2.5			
PK2913-01AA PK2913-01BA	Bipolar (Series)	9.3	1320	1.4	10	7.6	76.8	4000×10 ⁻⁷	22	6
	Unipolar	6.6	930	2	7.6	3.8	19.2			
PK2913-02AA PK2913-02BA	Bipolar (Series)	9.3	1320	2.8	5.3	1.94	16.8	4000×10 ⁻⁷	22	6
	Unipolar	6.6	930	4	3.8	0.97	4.2			
PK2913-F4.0A PK2913-F4.0B	Bipolar (Parallel)	9.3	1320	5.6	2.6	0.49	4.2	4000×10 ⁻⁷	22	8
	Bipolar (Series)	9.3	1320	2.8	5.3	1.94	16.8			
	Unipolar	6.6	930	4	3.8	0.97	4.2			

• Wirings and connections → Page A-288

Dimensions Unit = mm (in.)

Model	L1	L2	Mass kg (lb.)	DXF
PK296-0□AA PK296-F4.5A	66 (2.60)	—	1.7 (3.7)	B122U
PK296-0□BA PK296-F4.5B		100 (3.94)		
PK299-0□AA PK299-F4.5A	96 (3.78)	—	2.8 (6.2)	B123U
PK299-0□BA PK299-F4.5B		130 (5.12)		
PK2913-0□AA PK2913-F4.0A	126 (4.96)	—	3.8 (8.4)	B124U
PK2913-0□BA PK2913-F4.0B		160 (6.30)		

• Enter the winding specification in the box (□) within the model name.

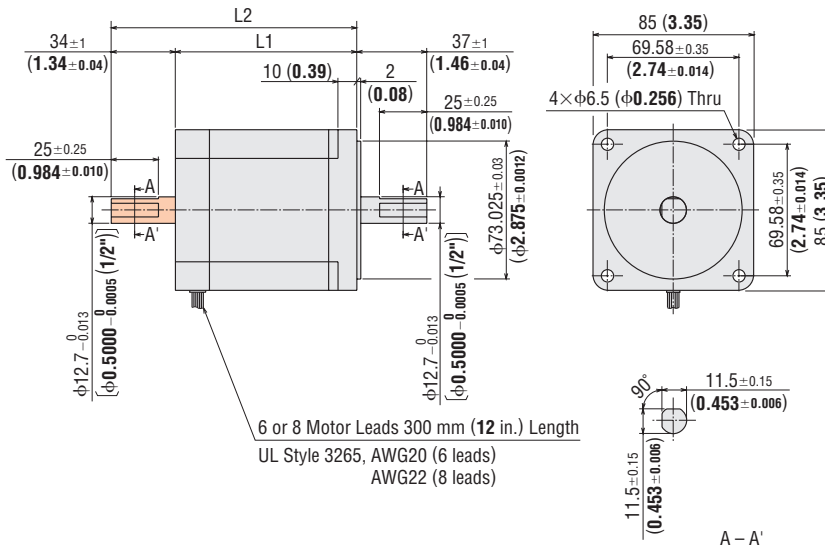

• These dimensions are for the double shaft models. For the single shaft models, ignore the orange (□) area.

Speed – Torque Characteristics

PK296-01□A

Bipolar (Series)

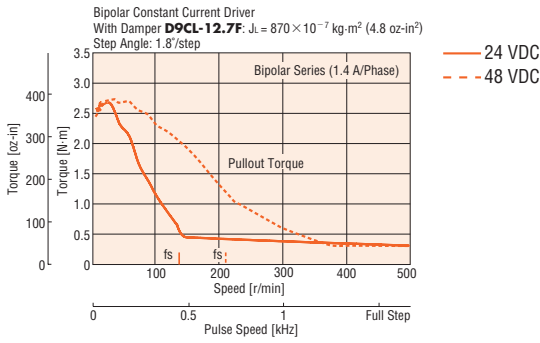

PK296-01□A

Unipolar

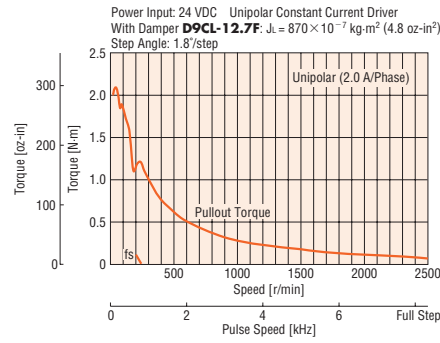

PK296-02□A

Bipolar (Series)

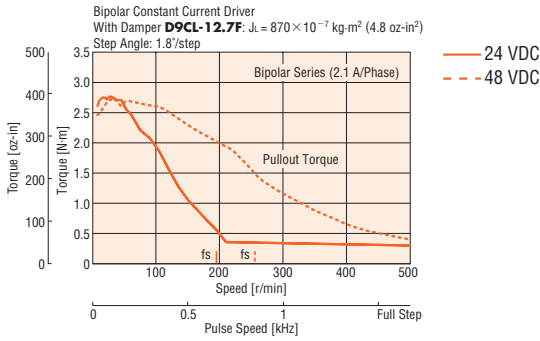

PK296-02□A

Unipolar

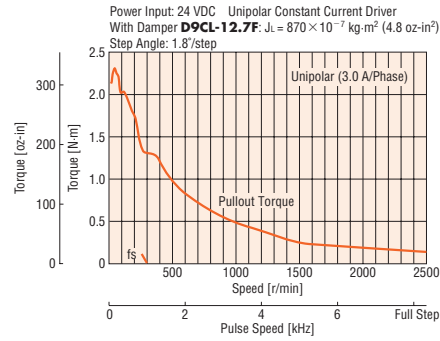

PK296-03□A

Bipolar (Series)

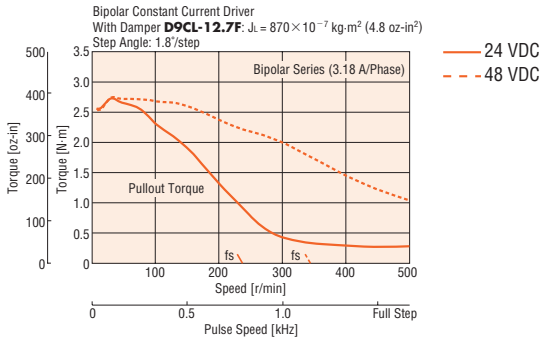

PK296-03□A

Unipolar

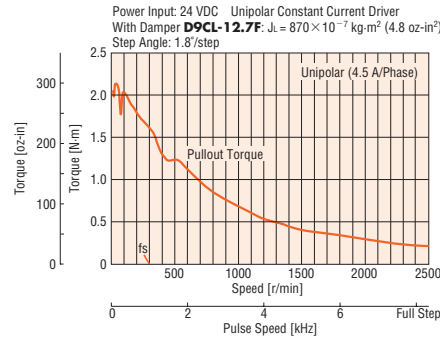

PK296-F4.5□

Bipolar (Parallel)

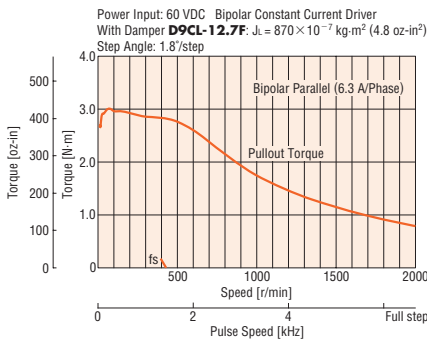

PK296-F4.5□

Bipolar (Series)

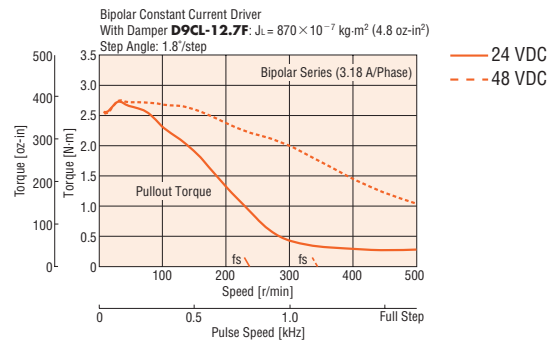

● Enter **A** (single shaft) or **B** (double shaft) in the box (□) within the model name.

Note

● Pay attention to heat dissipation from motor as there will be a considerable amount of heat under certain conditions. Be sure to keep the temperature of the motor case under 100°C (212°F).

Introduction	AC Input Motor & Driver	Motor Only
AR	0.36° / Geared	PK
AS	0.72° / Geared	PK
RK	0.9° / 1.8°	PK
UMK	0.36° / Geared	PK
ASX	0.36° / Geared	PK
CRK	0.36° / 0.72° / Geared	PK
CMK	0.9° / 1.8° / Geared	PK
RBK	1.8° / Geared	PK
PK	0.36°	PK
PK	0.72°	PK
PK	0.9°	PK
PK/PV	1.8°	PK
Geared	PK	PK
Controllers	SCX10 / EMP400 / SG80301	Accessories

- 20 mm (□ 0.79 in.)
- 28 mm (□ 1.10 in.)
- 35 mm (□ 1.38 in.)
- 42 mm (□ 1.65 in.)
- 50 mm (□ 1.97 in.)
- 56.4 mm (□ 2.22 in.)
- 60 mm (□ 2.36 in.)
- 85 mm (□ 3.35 in.)
- 90 mm (□ 3.54 in.)

Speed – Torque Characteristics

PK299-01□A

Bipolar (Series)

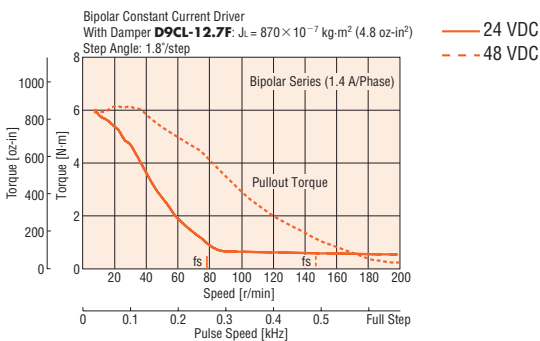

PK299-01□A

Unipolar

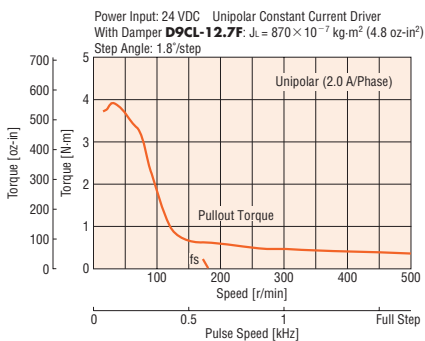

PK299-02□A

Bipolar (Series)

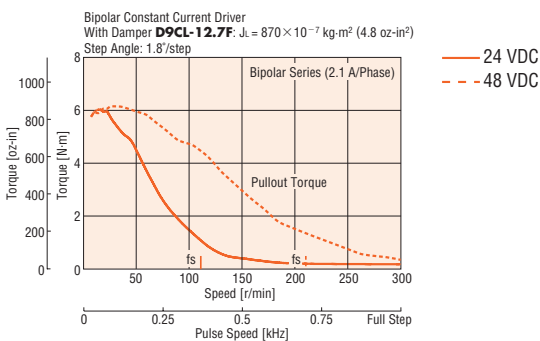

PK299-02□A

Unipolar

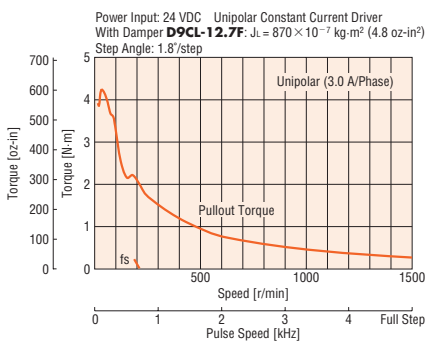

PK299-03□A

Bipolar (Series)

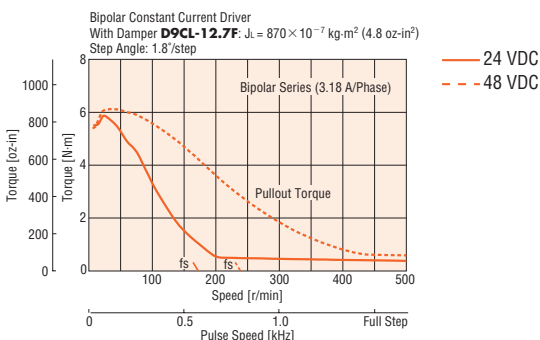

PK299-03□A

Unipolar

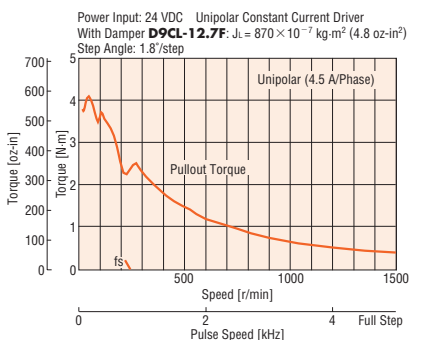

PK299-F4.5□

Bipolar (Parallel)

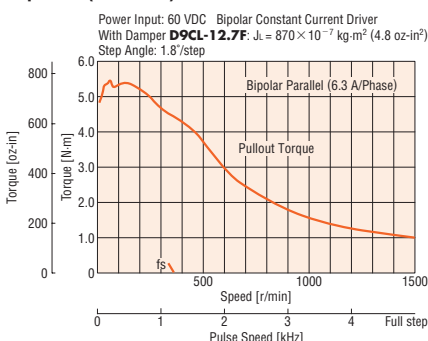

PK299-F4.5□

Bipolar (Series)

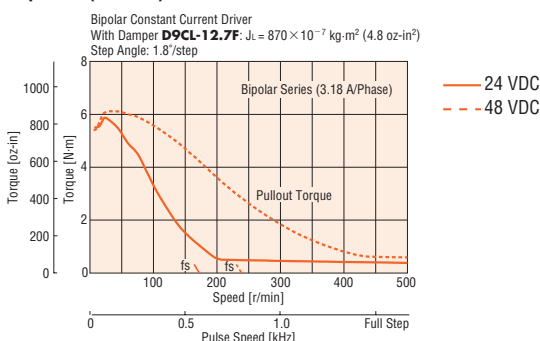

● Enter **A** (single shaft) or **B** (double shaft) in the box (□) within the model name.

Note

● Pay attention to heat dissipation from motor as there will be a considerable amount of heat under certain conditions. Be sure to keep the temperature of the motor case under 100°C (212°F).

PK2913-01□A Bipolar (Series)

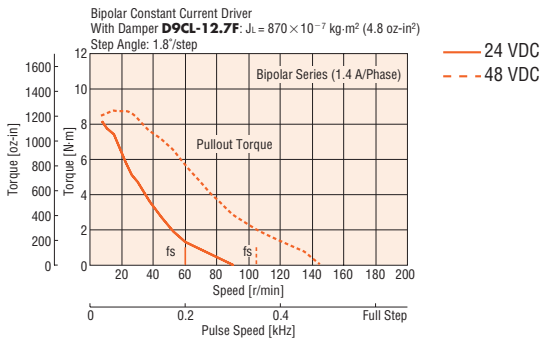

PK2913-01□A Unipolar

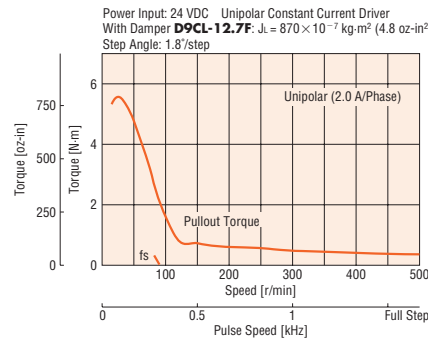

PK2913-02□A Bipolar (Series)

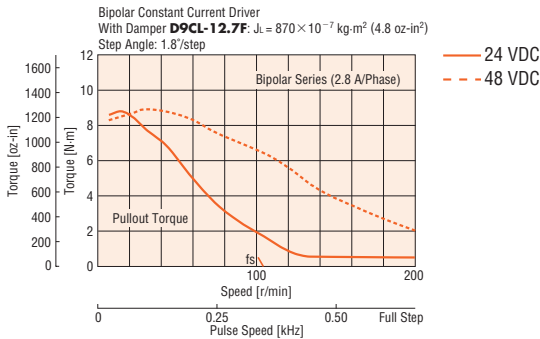

PK2913-02□A Unipolar

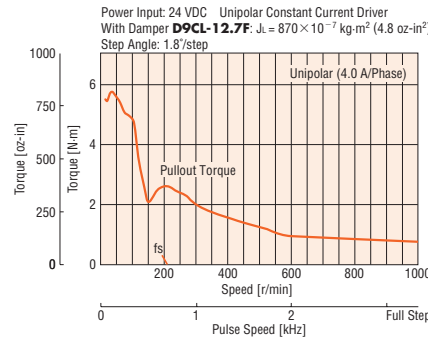

PK2913-F4.0□ Bipolar (Parallel)

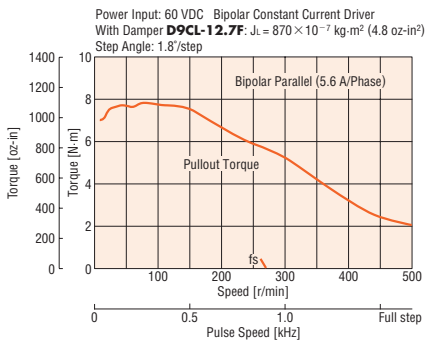

PK2913-F4.0□ Bipolar (Series)

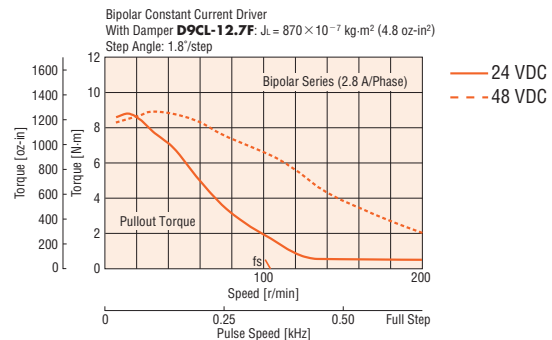

● Enter **A** (single shaft) or **B** (double shaft) in the box (□) within the model name.

Note

● Pay attention to heat dissipation from motor as there will be a considerable amount of heat under certain conditions.
Be sure to keep the temperature of the motor case under 100°C (212°F).

Introduction	AC Input Motor & Driver	DC Input Motor & Driver	Motor Only	Controllers	Accessories
AR	0.36° / Geared	0.36° / Geared	0.9° / 1.8°	SCX10	
AS	0.72° / Geared	0.36° / Geared	0.9° / 1.8°	EMP400	
RK	0.72° / Geared	0.36° / Geared	0.9° / 1.8°	SG8030J	
UMK	0.9° / 1.8°	0.36° / Geared	1.8° / Geared		
AR	0.36° / Geared	0.36° / Geared	1.8° / Geared		
ASX	0.36° / Geared	0.36° / Geared	1.8° / Geared		
CRK	0.36° / Geared	0.36° / Geared	1.8° / Geared		
CMK	0.9° / 1.8° / Geared	0.9° / 1.8° / Geared	1.8° / Geared		
RBK	1.8° / Geared	1.8° / Geared	1.8° / Geared		
PK	0.36°	0.36°	0.9°		
PK	0.72°	0.72°	0.9°		
PK	0.9°	0.9°	0.9°		
PK/PV	1.8°	1.8°	1.8°		
PK	Geared	Geared	Geared		
PK	Geared	Geared	Geared		

Step Angle 1.8°

Motor Frame Size 85 mm (3.35 in.)

PK Series Standard Type Terminal Box



Specifications RoHS



Model • Single Shaft	Connection Type	Holding Torque		Rated Current A/phase	Voltage VDC	Resistance Ω/phase	Inductance mH/phase	Rotor Inertia J		Lead Wires (Terminals)	Corresponding DC-Input Motor & Driver Package
		N-m	oz-in					kg-m ²	oz-in ²		
PK296EAT	Bipolar (Parallel)	3.1	440	6.3	1.4	0.24	1.5	1400×10 ⁻⁷	7.7	8	RBK296T
	Bipolar (Series)	3.1	440	3.18	2.8	0.96	6.0				
	Unipolar	2.2	310	4.5	2	0.48	1.5				
PK299EAT	Bipolar (Parallel)	6.2	880	6.3	1.9	0.33	2.5	2700×10 ⁻⁷	14.8	8	RBK299T
	Bipolar (Series)	6.2	880	3.18	3.9	1.32	10.0				
	Unipolar	4.4	620	4.5	2.8	0.66	2.5				
PK2913EAT	Bipolar (Parallel)	9.3	1320	5.6	2.6	0.49	4.2	4000×10 ⁻⁷	22	8	RBK2913T
	Bipolar (Series)	9.3	1320	2.8	5.3	1.94	16.8				
	Unipolar	6.6	930	4	3.8	0.97	4.2				

● Wirings and connections → Page A-288

● Degree of protection: IP65*

*Excluding the gap between the shaft and the flange.

Dimensions Unit = mm (in.)

Model	L	Mass kg (lb.)	DXF
PK296EAT	110 (4.33)	2.1 (4.6)	B379
PK299EAT	140 (5.51)	3.2 (7)	B380
PK2913EAT	170 (6.69)	4.3 (9.5)	B381

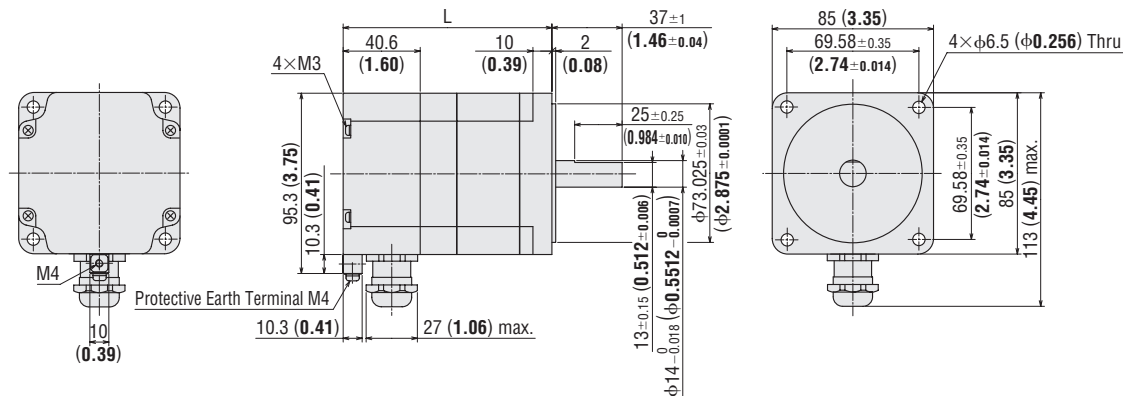

● Use cable (VCT) with a diameter of φ7~φ13 mm (φ0.28~φ0.51 in.). A connection cable is available as an accessory (sold separately). → Page A-409

Speed – Torque Characteristics

PK296EAT

Bipolar (Parallel)

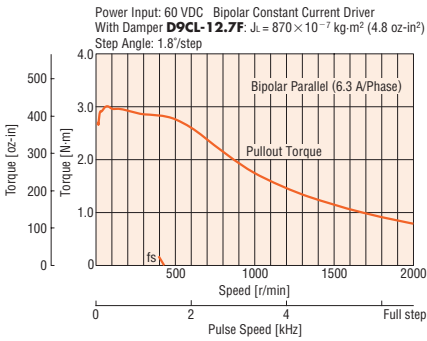

PK296EAT

Bipolar (Series)

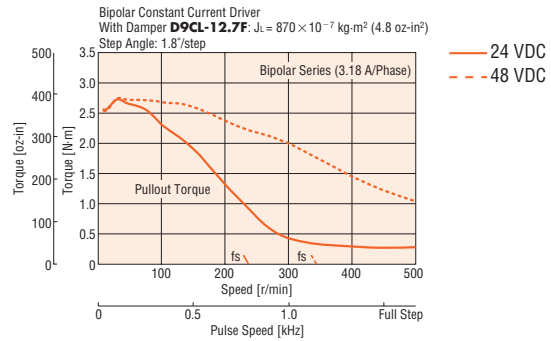

PK299EAT

Bipolar (Parallel)

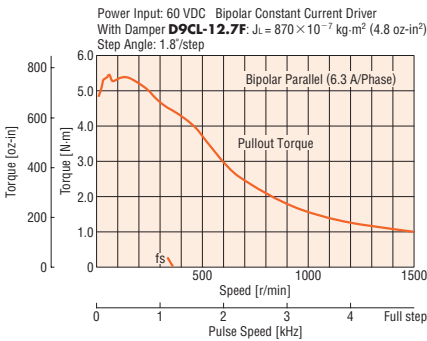

PK299EAT

Bipolar (Series)

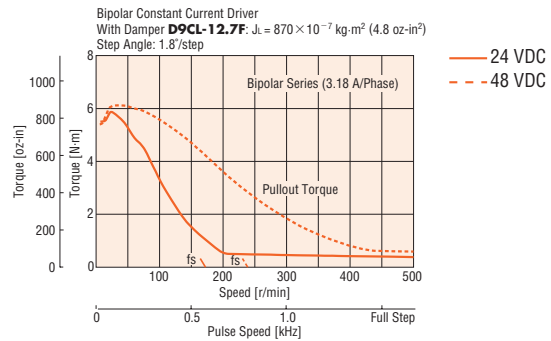

PK2913EAT

Bipolar (Parallel)

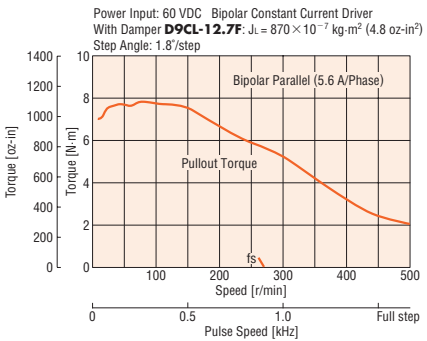

PK2913EAT

Bipolar (Series)

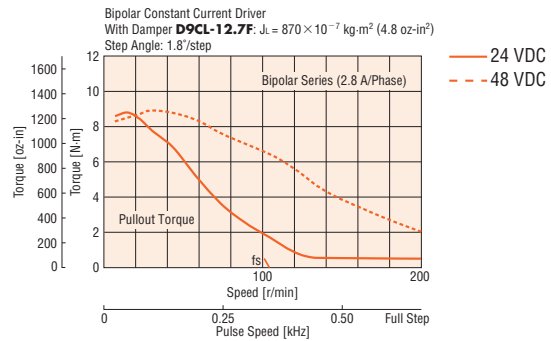

Note

- Pay attention to heat dissipation from motor as there will be a considerable amount of heat under certain conditions. Be sure to keep the temperature of the motor case under 100°C (212°F).

Introduction	
AR	DC Input Motor & Driver
AS	0.36° / Geared / 0.72° / Geared
RK	0.9°/1.8°
UMK	
AR	DC Input Motor & Driver
ASX	0.36° / Geared / 0.36° / Geared
CRK	0.36°/0.72° / Geared
CMK	0.9°/1.8° / Geared
RBK	1.8° / Geared
PK	0.36°
PK	0.72°
PK	0.9°
PK/PV	1.8°
PK	Geared
SCX10 / EMP400 / SG80301	Controllers
	Accessories

SH Geared Type

Motor Frame Size 28 mm (1.10 in.)

PK Series



20 mm
(0.79 in.)

28 mm
(1.10 in.)

35 mm
(1.38 in.)

42 mm
(1.65 in.)

50 mm
(1.97 in.)

56.4 mm
(2.22 in.)

60 mm
(2.36 in.)

85 mm
(3.35 in.)

90 mm
(3.54 in.)

Specifications (RoHS)

Motor Specifications

Model	Connection Type	Rated Current	Voltage	Resistance	Inductance	Rotor Inertia J		Lead Wires (Pins)	Corresponding DC-Input Motor & Driver Package
		A/phase	VDC	Ω/phase	mH/phase	kg·m ²	oz·in ²		
PK223PA-SG□ PK223PB-SG□ PK223PAR15S□	Bipolar (Series)	0.67	3.8	5.6	4	9×10 ⁻⁷	0.049	6	CMK223□P-SG□/ CMK223PR15S□
	Unipolar	0.95	2.66	2.8	1				

- Wirings and connections → Page A-288
- Encoder specifications → Page A-17
- Enter **A** (single shaft) or **B** (double shaft) in the box (□) within the model name.
- Enter the gear ratio in the box (■) within the model name.
- Product Number Code → Page A-278
- Backlash value is approximately 1 to 2°.

Note

- Direction of rotation of the motor and that of the gear output shaft are the same for the gear ratios 7.2 and 36. It is opposite for 9, 10 and 18 gear ratios.

Gearmotor Specifications

Model	Gear Ratio	Holding Torque*		Step Angle	Permissible Speed r/min
		N·m	oz·in		
PK223P□-SG7.2 PK223PAR15S7.2	7.2	0.3	42	0.25°	250
PK223P□-SG9 PK223PAR15S9	9	0.3	42	0.2°	200
PK223P□-SG10 PK223PAR15S10	10	0.3	42	0.18°	180
PK223P□-SG18 PK223PAR15S18	18	0.4	56	0.1°	100
PK223P□-SG36 PK223PAR15S36	36	0.4	56	0.05°	50

- Enter **A** (Single shaft) or **B** (double shaft) in the box (□) within the model name.

* Holding torque is the same regardless of the connection type due to the permissible torque limit of the gearhead.

Dimensions Unit = mm (in.)

The dimension of a motor with an encoder can be found on page A-19 or at www.orientalmotor.com.

Model	Mass kg (lb.)	DXF
PK223PA-SG□ PK223PB-SG□	0.16 (0.35)	B335

- Enter the gear ratio in the box (□) within the model name.
- Lead wire and connector are not supplied with the connector-coupled motor and must be purchased separately.
- Connection cable is available as an accessory (sold separately).
- Screws (Included)
M2.5 Length 8 mm (0.31 in.)...4 pieces
- Applicable Connector
Connector housing: 51065-0600 (MOLEX)
Contact: 50212-8100 (MOLEX)
Crimp tool: 57176-5000 (MOLEX)

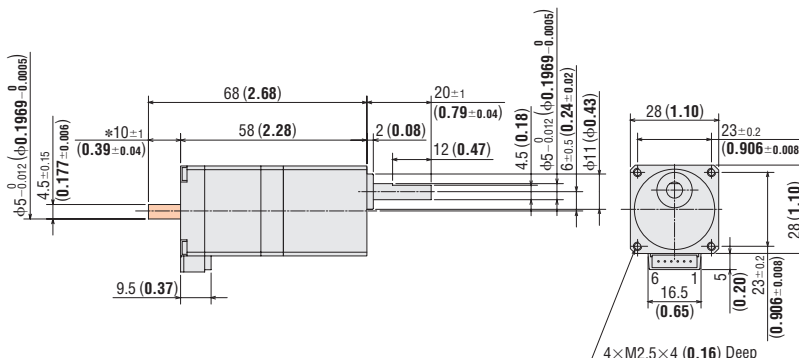

* The length of machining on the double shaft model is 10±0.25 (0.394±0.010).

- These dimensions are for the double shaft models. For the single shaft models, ignore the orange (■) area.

Speed – Torque Characteristics

PK223P□-SG■/PK223PAR15S■

Bipolar (Series) 24 VDC

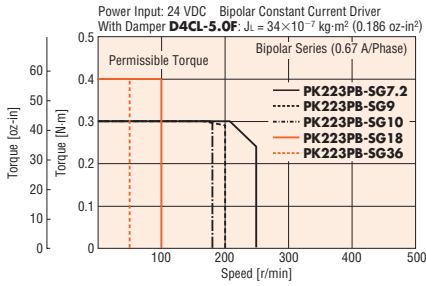

PK223P□-SG■/PK223PAR15S■

Unipolar

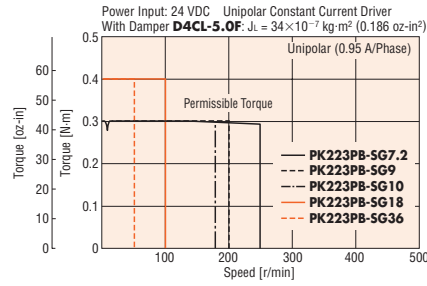

PK223P□-SG■/PK223PAR15S■

Bipolar (Series) 48 VDC

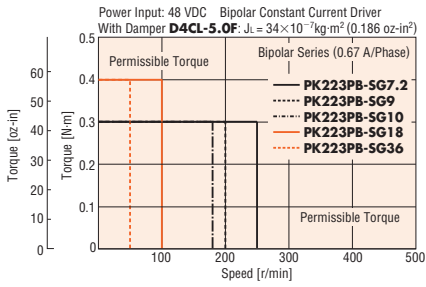

- Enter **A** (single shaft) or **B** (double shaft) in the box (□) within the model name.
- Enter the gear ratio in the box (■) within the model name.

Note

- Pay attention to heat dissipation from motor as there will be a considerable amount of heat under certain conditions. Be sure to keep the temperature of the motor case under 100°C (212°F).

Accessories (Sold separately)

The connection cable is available as an accessory.

- Connection cable → Page A-409

Introduction	
AR	0.36° / Geared
AS	AC Input Motor & Driver
RK	0.72° / Geared
UMK	0.9°/1.8°
AR	0.36° / Geared
ASX	DC Input Motor & Driver
CRK	0.36°/0.72° / Geared
CMK	0.9°/1.8° / Geared
RBK	1.8° / Geared
PK	0.36°
PK	0.72°
PK	0.9°
PK/PV	1.8°
PK	Geared
SCX10 / EMP400 / SG8030J	Controllers
	Accessories

SH Geared Type

Motor Frame Size 42 mm (1.65 in.)

PK Series



Specifications (RoHS)

Motor Specifications

Model • Single Shaft • Double Shaft • with Encoder	Connection Type	Rated Current A/phase	Voltage VDC	Resistance Ω/phase	Inductance mH/phase	Rotor Inertia J		Lead Wires	Corresponding DC-Input Motor & Driver Package CMK Series
						kg-m ²	oz-in ²		
PK243A1A-SG PK243B1A-SG PK243A1AR-S	Bipolar (Series)	0.67	5.6	8.4	10	35×10 ⁻⁷	0.191	6	CMK243□PA-SG/ CMK243PAR□S
	Unipolar	0.95	4.0	4.2	2.5				
PK243A2A-SG PK243B2A-SG	Bipolar (Series)	0.28	13	48	60	35×10 ⁻⁷	0.191	6	-
	Unipolar	0.4	9.6	24	15				

- Wirings and connections → Page A-288
- Encoder specifications → Page A-17
- Enter **A** (single shaft) or **B** (double shaft) in the box (□) within the model name.
Enter the gear ratio in the box (■) within the model name.
Enter the encoder code (**15**, **16**, **25** or **26**) in the box (□) within the model name.
Product Number Code → Page A-278
- Backlash value is approximately 1 to 2°.

Note

- Direction of rotation of the motor and that of the gear output shaft are the same for the gear ratios 3.6, 7.2, 9 and 10.
It is opposite for 18 and 36 gear ratios.

Gearmotor Specifications

Model • Single Shaft/Double Shaft • with Encoder	Gear Ratio	Holding Torque*		Step Angle	Permissible Speed r/min
		N-m	lb-in		
PK243□1A-SG3.6, PK243□2A-SG3.6 PK243A1AR□S3.6	3.6	0.2	1.77	0.5°	500
PK243□1A-SG7.2, PK243□2A-SG7.2 PK243A1AR□S7.2	7.2	0.4	3.5	0.25°	250
PK243□1A-SG9, PK243□2A-SG9 PK243A1AR□S9	9	0.5	4.4	0.2°	200
PK243□1A-SG10, PK243□2A-SG10 PK243A1AR□S10	10	0.56	4.9	0.18°	180
PK243□1A-SG18, PK243□2A-SG18 PK243A1AR□S18	18	0.8	7.0	0.1°	100
PK243□1A-SG36, PK243□2A-SG36 PK243A1AR□S36	36	0.8	7.0	0.05°	50

- Enter **A** (Single shaft) or **B** (double shaft) in the box (□) within the model name.
Enter the encoder code (**15**, **16**, **25** or **26**) in the box (□) within the model name.
- *Holding torque is the same regardless of the connection type due to the permissible torque limit of the gearhead.

Dimensions Unit = mm (in.)

The dimension of a motor with an encoder can be found on page A-19 or at www.orientalmotor.com.

Model	Mass kg (lb.)	DXF
PK243A□A-SG	0.35 (0.77)	B091U
PK243B□A-SG		

- Enter the winding specification in the box (□) within the model name.
- Enter the gear ratio in the box (■) within the model name.
- Screws (Included)
No.4-40 UNC Length 10 mm (0.39 in.)...4 pieces

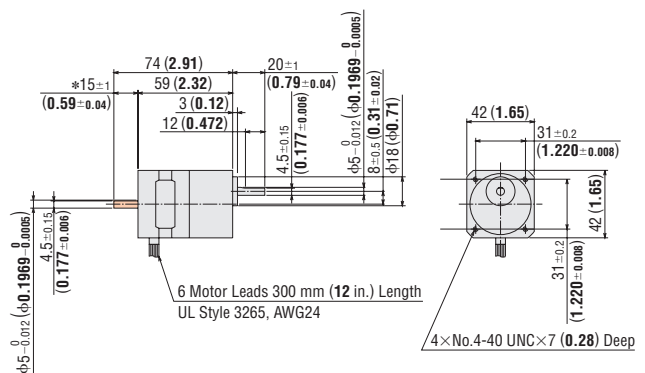

* The length of machining on the double shaft model is 15±0.25 (0.591±0.010).

- These dimensions are for the double shaft models. For the single shaft models, ignore the orange (■) area.

Speed – Torque Characteristics

PK243 1A-SG / PK243A1AR S

Bipolar (Series) 24 VDC

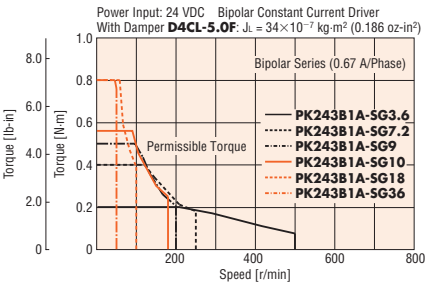

PK243 1A-SG / PK243A1AR S

Unipolar

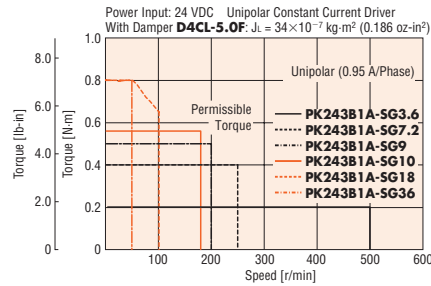

PK243 1A-SG / PK243A1AR S

Bipolar (Series) 48 VDC

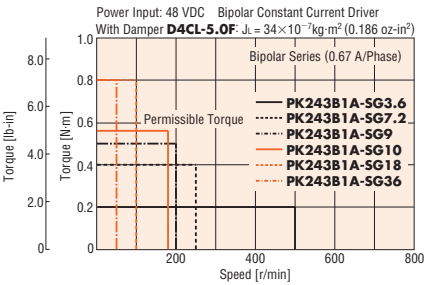

PK243 2A-SG

Bipolar (Series) 24 VDC

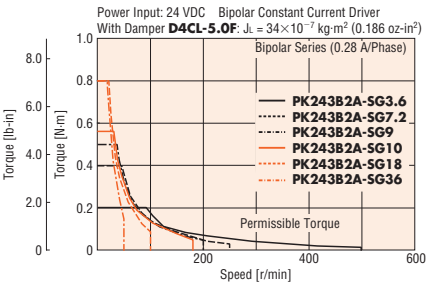

PK243 2A-SG

Unipolar

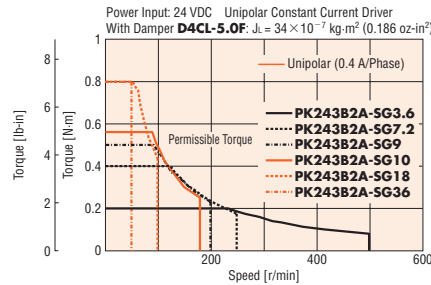

PK243 2A-SG

Bipolar (Series) 48 VDC

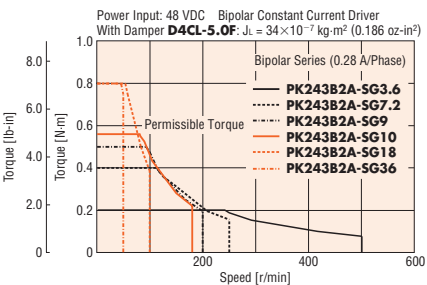

- Enter **A** (single shaft) or **B** (double shaft) in the box (□) within the model name.
- Enter the gear ratio in the box (■) within the model name.
- Enter the encoder code (**15**, **16**, **25** or **26**) in the box (□) within the model name.

Note

- Pay attention to heat dissipation from motor as there will be a considerable amount of heat under certain conditions. Be sure to keep the temperature of the motor case under 100°C (212°F).

Introduction	
AR	AC Input Motor & Driver
AR	0.36° / Geared
AS	0.72° / Geared
RK	0.9° / 1.8°
UMK	0.36° / Geared
AR	0.36° / Geared
ASX	0.36° / Geared
CRK	0.36° / 0.72° / Geared
CMK	0.9° / 1.8° / Geared
RBK	1.8° / Geared
PK	0.36°
PK	0.72°
PK	0.9°
PK/PV	1.8°
PK	Geared
SCX10 / EMP400 / SG80301	Controllers
	Accessories

SH Geared Type

Motor Frame Size 60 mm (2.36 in.)

PK Series



20 mm (0.79 in.)

28 mm (1.10 in.)

35 mm (1.38 in.)

42 mm (1.65 in.)

50 mm (1.97 in.)

56.4 mm (2.22 in.)

60 mm (2.36 in.)

85 mm (3.35 in.)

90 mm (3.54 in.)

Specifications (RoHS)

Motor Specifications

Model	Connection Type	Rated Current	Voltage	Resistance	Inductance	Rotor Inertia J		Lead Wires (Pins)	Corresponding DC-Input Motor & Driver Package
		A/phase	VDC	Ω/phase	mH/phase	kg·m ²	oz·in ²		
PK264A1A-SG <input type="checkbox"/> PK264B1A-SG <input type="checkbox"/>	Bipolar (Series)	0.71	8.1	11.4	21.6	120×10 ⁻⁷	0.66	6	-
	Unipolar	1	5.7	5.7	5.4				
PK264A2A-SG <input type="checkbox"/> PK264B2A-SG <input type="checkbox"/> PK264A2AR <input type="checkbox"/> S <input type="checkbox"/>	Bipolar (Series)	1.4	3.9	2.8	5.6	120×10 ⁻⁷	0.66	6	CMK264 <input type="checkbox"/> PA-SG <input type="checkbox"/> CMK264PAR <input type="checkbox"/> S <input type="checkbox"/>
	Unipolar	2	2.8	1.4	1.4				

- Wirings and connections → Page A-288
Encoder specifications → Page A-17
- Enter **A** (single shaft) or **B** (double shaft) in the box (□) within the model name.
Enter the gear ratio in the box (■) within the model name.
Enter the encoder code (**15**, **16**, **25** or **26**) in the box (□) within the model name.
Product Number Code → Page A-278
- Backlash value is approximately 1 to 2°.

Note

- Direction of rotation of the motor and that of the gear output shaft are the same for the gear ratios 3.6, 7.2, 9 and 10.
It is opposite for 18 and 36 gear ratios.

Gearmotor Specifications

Model •Single Shaft/Double Shaft	Gear Ratio	Holding Torque*		Step Angle	Permissible Speed r/min
		N·m	lb·in		
PK264 <input type="checkbox"/> 1A-SG3.6, PK264 <input type="checkbox"/> 2A-SG3.6 PK264A2AR <input type="checkbox"/> S3.6	3.6	1	8.8	0.5°	500
PK264 <input type="checkbox"/> 1A-SG7.2, PK264 <input type="checkbox"/> 2A-SG7.2 PK264A2AR <input type="checkbox"/> S7.2	7.2	2	17.7	0.25°	250
PK264 <input type="checkbox"/> 1A-SG9, PK264 <input type="checkbox"/> 2A-SG9 PK264A2AR <input type="checkbox"/> S9	9	2.5	22	0.2°	200
PK264 <input type="checkbox"/> 1A-SG10, PK264 <input type="checkbox"/> 2A-SG10 PK264A2AR <input type="checkbox"/> S10	10	2.7	23	0.18°	180
PK264 <input type="checkbox"/> 1A-SG18, PK264 <input type="checkbox"/> 2A-SG18 PK264A2AR <input type="checkbox"/> S18	18	3	26	0.1°	100
PK264 <input type="checkbox"/> 1A-SG36, PK264 <input type="checkbox"/> 2A-SG36 PK264A2AR <input type="checkbox"/> S36	36	4	35	0.05°	50

- Enter **A** (Single shaft) or **B** (double shaft) in the box (□) within the model name.
Enter the encoder code (**15**, **16**, **25** or **26**) in the box (□) within the model name.
- *Holding torque is the same regardless of the connection type due to the permissible torque limit of the gearhead.

Dimensions Unit = mm (in.)

The dimension of a motor with an encoder can be found on page A-19 or at www.orientalmotor.com.

Model	Mass kg (lb.)	DXF
PK264A <input type="checkbox"/> A-SG <input type="checkbox"/>	0.75 (1.7)	B092U
PK264B <input type="checkbox"/> A-SG <input type="checkbox"/>		

- Enter the winding specification in the box (□) within the model name.
Enter the gear ratio in the box (■) within the model name.
- Screws (Included)
No.8-32 UNC Length 15.8 mm (0.62 in.)...4 pieces

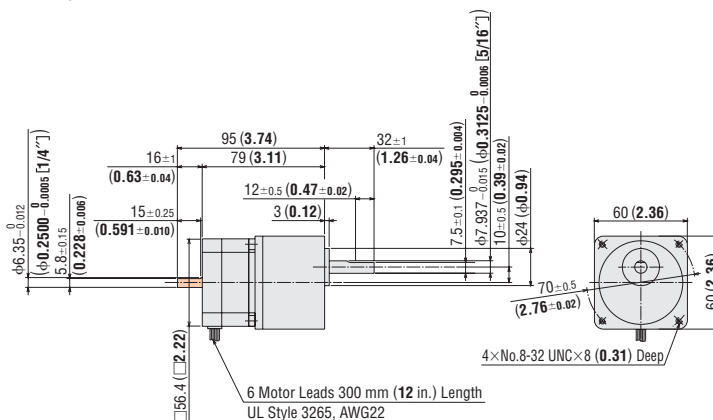

- These dimensions are for the double shaft models. For the single shaft models, ignore the orange (■) area.

Speed – Torque Characteristics

PK264 1A-SG

Bipolar (Series) 24 VDC

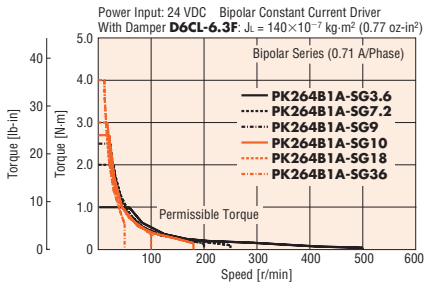

PK264 1A-SG

Unipolar

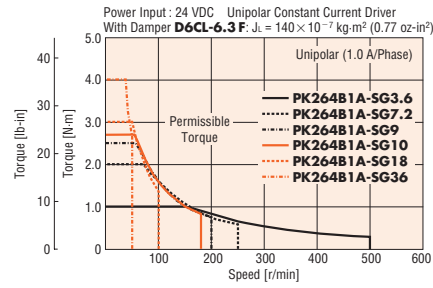

PK264 1A-SG

Bipolar (Series) 48 VDC

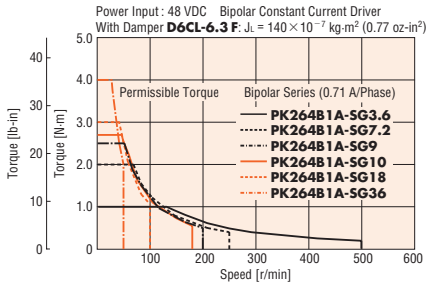

PK264 2A-SG / PK264A2AR S

Bipolar (Series) 24 VDC

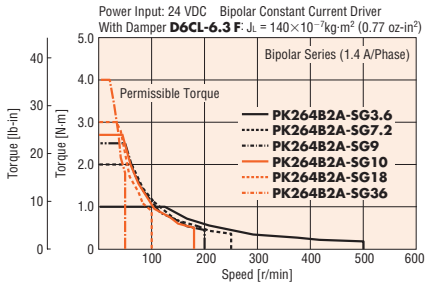

PK264 2A-SG / PK264A2AR S

Unipolar

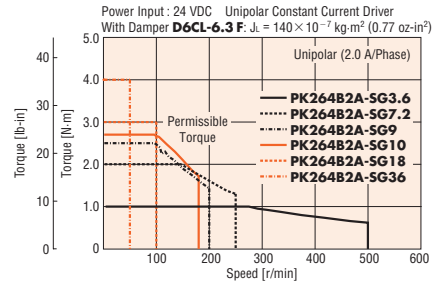

PK264 2A-SG / PK264A2AR S

Bipolar (Series) 48 VDC

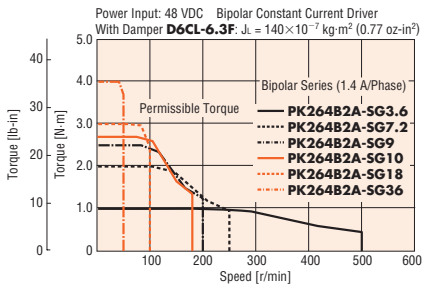

- Enter **A** (single shaft) or **B** (double shaft) in the box () within the model name.
- Enter the gear ratio in the box () within the model name.
- Enter the encoder code (**15**, **16**, **25** or **26**) in the box () within the model name.

Note

- Pay attention to heat dissipation from motor as there will be a considerable amount of heat under certain conditions. Be sure to keep the temperature of the motor case under 100°C (212°F).

Introduction	
AR	0.36° / Geared
AS	AC Input Motor & Driver
RK	0.72° / Geared
UMK	0.9°/1.8°
AR	0.36° / Geared
ASX	0.36° / Geared
CRK	0.36°/0.72° / Geared
CMK	0.9°/1.8° / Geared
RBK	1.8° / Geared
PK	0.36°
PK	0.72°
PK	0.9°
PK/PV	1.8°
PK	Geared
SCX10 / EMP400 / SG80301	Controllers
	Accessories

SH Geared Type

Motor Frame Size 90 mm (3.54 in.)

PK Series



Specifications (RoHS)

Motor Specifications

Model • Single Shaft • Double Shaft	Connection Type	Rated Current	Voltage	Resistance	Inductance	Rotor Inertia J		Lead Wires
		A/phase	VDC	Ω/phase	mH/phase	kg·m ²	oz·in ²	
PK296A1A-SG <input type="checkbox"/> PK296B1A-SG <input type="checkbox"/>	Bipolar (Series)	1	4.4	4.4	30.8	1400×10 ⁻⁷	7.7	6
	Unipolar	1.5	3.3	2.2	7.7			
PK296A2A-SG <input type="checkbox"/> PK296B2A-SG <input type="checkbox"/>	Bipolar (Series)	2.1	2	0.96	6	1400×10 ⁻⁷	7.7	6
	Unipolar	3	1.4	0.48	1.5			

- Wiring and connections → Page A-288
Enter the gear ratio in the box () within the model name.
- Backlash value is approximately 1 to 2°.

Note

- Direction of rotation of the motor and that of the gear output shaft are the same for the gear ratios 3.6, 7.2, 9, 10 and 18.
It is opposite for 36 gear ratios.

Gearmotor Specifications

Model • Single Shaft • Double Shaft	Gear Ratio	Holding Torque*		Step Angle	Permissible Speed r/min
		N·m	lb·in		
PK296A1A-SG3.6 , PK296A2A-SG3.6 PK296B1A-SG3.6 , PK296B2A-SG3.6	3.6	2.5	22	0.5°	500
PK296A1A-SG7.2 , PK296A2A-SG7.2 PK296B1A-SG7.2 , PK296B2A-SG7.2	7.2	5	44	0.25°	250
PK296A1A-SG9 , PK296A2A-SG9 PK296B1A-SG9 , PK296B2A-SG9	9	6.3	55	0.2°	200
PK296A1A-SG10 , PK296A2A-SG10 PK296B1A-SG10 , PK296B2A-SG10	10	7	61	0.18°	180
PK296A1A-SG18 , PK296A2A-SG18 PK296B1A-SG18 , PK296B2A-SG18	18	9	79	0.1°	100
PK296A1A-SG36 , PK296A2A-SG36 PK296B1A-SG36 , PK296B2A-SG36	36	12	106	0.05°	50

*Holding torque is the same regardless of the connection type due to the permissible torque limit of the gearhead.

Dimensions Unit = mm (in.)

Model	L1	L2	Mass kg (lb.)	DXF
PK296A <input type="checkbox"/> A-SG <input type="checkbox"/>	126 (4.96)	—	2.8 (6.2)	B242U
PK296B <input type="checkbox"/> A-SG <input type="checkbox"/>		160 (6.3)		

- Enter the winding specification in the box () within the model name.
Enter the gear ratio in the box () within the model name.
- Screws (Included)
1/4-20 UNC, Length 19 mm (0.75 in.)—4 pieces

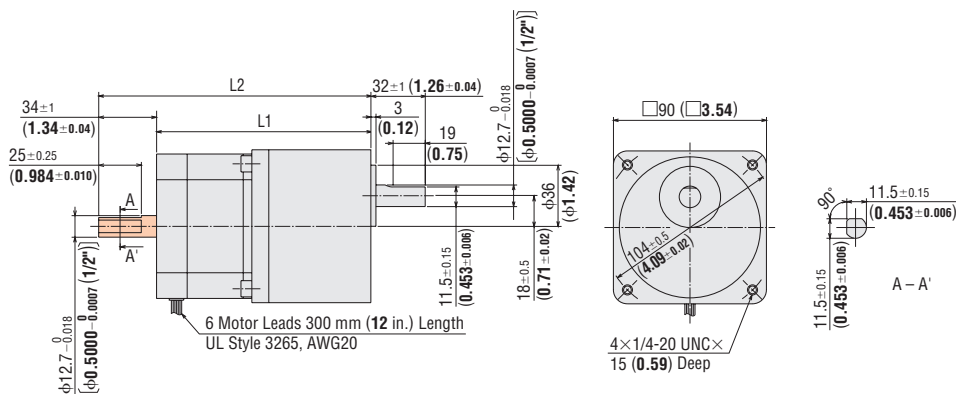

- These dimensions are for the double shaft models. For the single shaft models, ignore the orange () area.

Speed – Torque Characteristics

PK296 1A-SG

Bipolar (Series) 24 VDC

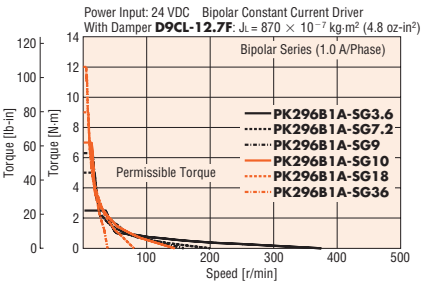

PK296 1A-SG

Unipolar

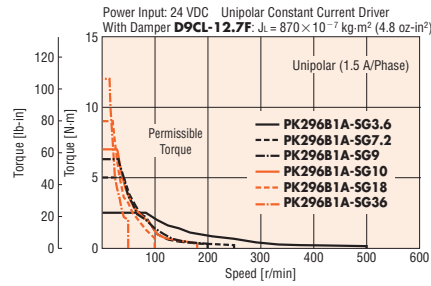

PK296 1A-SG

Bipolar (Series) 48 VDC

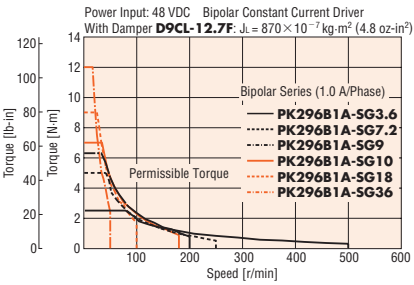

PK296 2A-SG

Bipolar (Series) 24 VDC

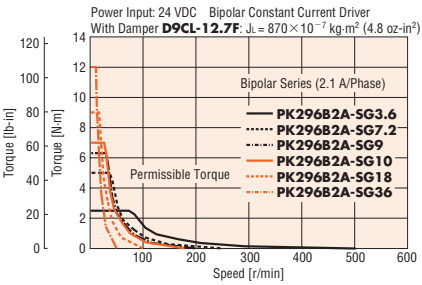

PK296 2A-SG

Unipolar

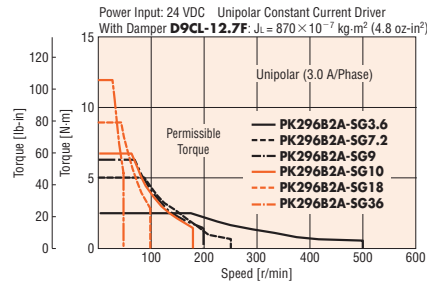

PK296 2A-SG

Bipolar (Series) 48 VDC

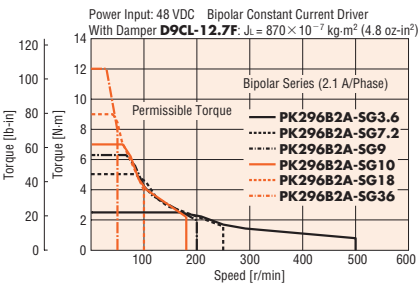

- Enter **A** (single shaft) or **B** (double shaft) in the box () within the model name.
- Enter the gear ratio in the box () within the model name.

Note

- Pay attention to heat dissipation from motor as there will be a considerable amount of heat under certain conditions. Be sure to keep the temperature of the motor case under 100°C (212°F).

Introduction	
AR	0.36° / Geared
AS	AC Input Motor & Driver
RK	0.72° / Geared
UMK	0.9°/1.8°
AR	0.36° / Geared
ASX	0.36° / Geared
CRK	0.36°/0.72° / Geared
CMK	0.9°/1.8° / Geared
RBK	1.8° / Geared
PK	0.36°
PK	0.72°
PK	0.9°
PK/PV	1.8°
PK	Geared
SCX10 / EMP400 / SG8030J	Controllers
	Accessories

TH Geared Type

Motor Frame Size 28 mm (1.10 in.), 42 mm (1.65 in.)
PK Series



20 mm (0.79 in.)
28 mm (1.10 in.)
35 mm (1.38 in.)
42 mm (1.65 in.)
50 mm (1.97 in.)
56.4 mm (2.22 in.)
60 mm (2.36 in.)
85 mm (3.35 in.)
90 mm (3.54 in.)

Specifications

Motor Specifications (RoHS)



Motor Frame Size	Model	Connection Type	Rated Current	Rotor Inertia J		Motor Lead Wires (Pins)	Corresponding Motor & Driver Package
mm (in.)	• Single Shaft/Double Shaft • with TTL Type Encoder • with Differential Type Encoder		A/phase	kg-m ²	oz-in ²		CRK Series (Pulse/Built-In Program)
28 (1.10)	PK523P □-T□	New Pentagon (Bipolar)	0.35	9×10 ⁻⁷	0.049	5	CRK523P □P-T□ CRK523P □KP-T□
42 (1.65)	PK543 □W-T□ PK543AWR27T □ PK543AWR27LT □		0.75	35×10 ⁻⁷	0.191		CRK543 □P-T□ CRK543 □KP-T□ CRK543APR27T □ CRK543RKPT □

- Wirings and connections → Page A-288, Encoder specifications → Page A-17
- See the page for the corresponding motor and driver package for speed-torque characteristics and dimensions.
- The dimensions of a motor with an encoder can be found on page A-20.
- The motor connection cable is available as an accessory.
- Enter the encoder code (**17**, **18**, **27** or **28**) in the box (□) within the model name.
Enter the **A** (single shaft) or **B** (double shaft) in the box (□) within the model name.
Product Number Code → Page A-278
- *1 Adopted for motor frame size 28 mm (1.10 in.) products.
- *2 Adopted for motor frame size 42 mm (1.65 in.) products.
- *3 CE Marking is applied to a corresponding motor and driver package product.

Gearmotor Specifications

Model		Gear Ratio	Maximum Holding Torque		Basic Step Angle	Backlash arc minute (degrees)	Permissible Speed Range
• Single Shaft/Double Shaft	• with TTL Type Encoder • with Differential Type Encoder		N-m	PK523 : oz-in PK543 : lb-in			
PK523P □-T7.2	—	7.2	0.2	28	0.1°	60 (1)	0~416
PK523P □-T10	—	10	0.3	42	0.072°		0~300
PK523P □-T20	—	20	0.4	56	0.036°		0~150
PK523P □-T30	—	30	0.5	71	0.024°		0~100
PK543 □W-T3.6	PK543AWR27T3.6 PK543AWR27LT3.6	3.6	0.35	3	0.2°	45 (0.75)	0~500
PK543 □W-T7.2	PK543AWR27T7.2 PK543AWR27LT7.2	7.2	0.7	6.1	0.1°	25 (0.42)	0~250
PK543 □W-T10	PK543AWR27T10 PK543AWR27LT10	10	1	8.8	0.072°		0~180
PK543 □W-T20	PK543AWR27T20 PK543AWR27LT20	20	1.5	13.2	0.036°	15 (0.25)	0~90
PK543 □W-T30	PK543AWR27T30 PK543AWR27LT30	30			0.024°		0~60

- Enter **A** (single shaft) or **B** (double shaft) in the box (□) within the model name.

Introduction of Stepping Motor and Driver Packages

Stepping motor and driver packages are available. Packages are outfitted with drivers specifically designed to obtain the motor's maximum performance.

AC Input Motor and Driver Package

RK Series → Page A-78



DC Input Motor and Driver Package

CRK Series → Page A-168



Pulse Input



Built-In Controller

TH Geared Type

Motor Frame Size 60 mm (2.36 in.), 90 mm (3.54 in.)

PK Series



Specifications

Motor Specifications



Motor Frame Size mm (in.)	Model • Single Shaft/Double Shaft • with TTL Type Encoder • with Differential Type Encoder	Connection Type	Rated Current A/phase	Rotor Inertia J kg·m ² oz·in ²		Motor Lead Wires (Pins)	Corresponding Motor & Driver Package RK Series CRK Series (Pulse/Built-In Program)
60 (2.36)	PK564 □ W-T □ PK564AWR27T □ PK564AWR27LT □	New Pentagon (Bipolar)	1.4	175×10 ⁻⁷	0.96	5	CRK564 □ P-T □ CRK564 □ KP-T □ CRK564APR27T □ CRK564RKPT □
90 (3.54)	PK596 □ E-T □ PK596 □ E1-T □ PK596AER27T □ PK596AE1R27T □			1400×10 ⁻⁷	7.7		RK596 □□ E-T □ RK596A □□ ER27T □

- Wirings and connections → Page A-288, Encoder specifications → Page A-17
- See the page for the corresponding motor and driver package for speed-torque characteristics and dimensions.
- The dimensions of a motor with an encoder can be found on page A-20.
- Enter the **A** (single shaft) or **B** (double shaft) in the box (□) within the model name.
Enter the gear ratio in the box (□) within the model name.
- Enter the **A** (single-phase 100-115 VAC) or **C** (single-phase 200-230 VAC) in the box (□) with in the model name.
- *CE Marking is applied to a corresponding motor and driver package product.

Gearmotor Specifications

Model • Single Shaft/Double Shaft • with TTL Type Encoder • with Differential Type Encoder		Gear Ratio	Maximum Holding Torque N·m PK564: oz·in PK596: lb·in		Basic Step Angle	Backlash arc minute (degrees)	Permissible Speed Range r/min
PK564 □ W-T3.6	PK564AWR27T3.6 PK564AWR27LT3.6	3.6	1.25	11	0.2°	35 (0.59)	0~500
PK564 □ W-T7.2	PK564AWR27T7.2 PK564AWR27LT7.2	7.2	2.5	22	0.1°	15 (0.25)	0~250
PK564 □ W-T10	PK564AWR27T10 PK564AWR27LT10	10	3	26	0.072°		0~180
PK564 □ W-T20	PK564AWR27T20 PK564AWR27LT20	20	3.5	30	0.036°	10 (0.17)	0~90
PK564 □ W-T30	PK564AWR27T30 PK564AWR27LT30	30	4	35	0.024°		0~60
PK596 □ E-T3.6	PK596AER27T3.6	3.6	4.5	39	0.2°	25 (0.42)	0~500
PK596 □ E-T7.2	PK596AER27T7.2	7.2	9	79	0.1°	15 (0.25)	0~250
PK596 □ E1-T10	PK596AE1R27T10	10			0.072°		0~180
PK596 □ E1-T20	PK596AE1R27T20	20	12	106	0.036°	10 (0.17)	0~90
PK596 □ E1-T30	PK596AE1R27T30	30			0.024°		0~60

- Enter **A** (single shaft) or **B** (double shaft) in the box (□) within the model name.

Introduction of Stepping Motor and Driver Packages

Stepping motor and driver packages are available. Packages are outfitted with drivers specifically designed to obtain the motor's maximum performance.

AC Input Motor and Driver Package

RK Series → Page A-78



DC Input Motor and Driver Package

CRK Series → Page A-168



Pulse Input



Built-In Controller

Introduction	
AC Input Motor & Driver	0.36° / Geared / AS
RK	0.72° / Geared
UMK	0.9°/1.8°
DC Input Motor & Driver	0.36° / Geared / ASX
CRK	0.36° / Geared / 0.72°
CMK	0.9°/1.8° / Geared
RBK	1.8° / Geared
Motor Only	0.36° / PK
	0.72° / PK
	0.9° / PK
	1.8° / PK/PV
	Geared / PK
Controllers	SCX10 / EMP400 / SG8030J
Accessories	

PS Geared Type

Motor Frame Size 28 mm (1.10 in.), 42 mm (1.65 in.)

PK Series



Specifications

Motor Specifications RoHS



Motor Frame Size mm (in.)	Model • Single Shaft/Double Shaft • with TTL Type Encoder • with Differential Type Encoder	Connection Type	Rated Current		Rotor Inertia J		Motor Lead Wires (Pins)	Corresponding Motor & Driver Package CRK Series (Pulse/Built-In Program)
			A/phase		kg·m ²	oz·in ²		
28 (1.10)	PK523P □- PS □	New Pentagon (Bipolar)	0.35		9×10 ⁻⁷	0.049	5	CRK523P □- P-PS □ CRK523P □- KP-PS □
42 (1.65)	PK545 □- W-PS □ PK545AWR27PS □ PK545AWR27LPS □		0.75		68×10 ⁻⁷	0.37		CRK545 □- P-PS □ CRK545 □- KP-PS □ CRK545APR27PS □ CRK545RKPPS □
	PK543 □- W-PS □ PK543AWR27PS □ PK543AWR27LPS □				35×10 ⁻⁷	0.191		CRK543 □- P-PS □ CRK543 □- KP-PS □ CRK543APR27PS □ CRK543RKPPS □

- Wirings and connections → Page A-288, Encoder specifications → Page A-17
- See the page for the corresponding motor and driver package for speed-torque characteristics and dimensions.
- The dimensions of a motor with an encoder can be found on page A-20.
- Enter the **A** (single shaft) or **B** (double shaft) in the box (□) within the model name.
A number indicating the gear ratio is entered when the box (■) is located within the model name.
- *1 Adopted for motor frame size 28 mm (1.10 in.) products.
- *2 Adopted for motor frame size 42 mm (1.65 in.) products.
- *3 CE Marking is applied to a corresponding motor and driver package product.

Gearmotor Specifications

Model		Gear Ratio	Maximum Holding Torque		Basic Step Angle	Backlash arc minute (degrees)	Permissible Speed Range r/min
• Single Shaft/Double Shaft	• with TTL Type Encoder • with Differential Type Encoder		N·m	PK52: oz·in PK54: lb·in			
PK523P □- PS5	—	5	0.2	28	0.144°	35 (0.59)	0~600
PK523P □- PS7	—	7.2	0.3	42	0.1°		0~416
PK523P □- PS10	—	10	0.4	56	0.072°		0~300
PK545 □- W-PS5	PK545AWR27PS5 PK545AWR27LPS5	5	1	8.8	0.144°	25 (0.42)	0~600
PK545 □- W-PS7	PK545AWR27PS7 PK545AWR27LPS7	7.2	1.5	13.2	0.1°		0~416
PK545 □- W-PS10	PK545AWR27PS10 PK545AWR27LPS10	10			0.072°		0~300
PK543 □- W-PS25	PK543AWR27PS25 PK543AWR27LPS25	25	2.5	22	0.0288°		0~120
PK543 □- W-PS36	PK543AWR27PS36 PK543AWR27LPS36	36	3	26	0.02°		0~83
PK543 □- W-PS50	PK543AWR27PS50 PK543AWR27LPS50	50			0.0144°		0~60

- Enter **A** (single shaft) or **B** (double shaft) in the box (□) within the model name.

Introduction of Stepping Motor and Driver Packages

Stepping motor and driver packages are available. Packages are outfitted with drivers specifically designed to obtain the motor's maximum performance.

AC Input
Motor and Driver Package
RK Series → Page A-78

DC Input
Motor and Driver Package
CRK Series → Page A-168

PS Geared Type

Motor Frame Size 60 mm (2.36 in.), 90 mm (3.54 in.)

PK Series



Specifications

Motor Specifications

Motor Frame Size mm (in.)	Model • Single Shaft/Double Shaft • with TTL Type Encoder • with Differential Type Encoder	Connection Type	Rated Current A/phase	Rotor Inertia J		Motor Lead Wires (Pins)	Corresponding Motor & Driver Package RK Series CRK Series (Pulse/Built-In Program)
				kg·m ²	oz·in ²		
60 (2.36)	PK566□W-PS□ PK566AWR27PS□ PK566AWR27LPS□	New Pentagon (Bipolar)	1.4	280×10 ⁻⁷	1.53	5	CRK566□P-PS□ CRK566□KP-PS□ CRK566APR27PS□ CRK566RKPPS□
	PK564□W-PS□ PK564AWR27PS□ PK564AWR27LPS□			175×10 ⁻⁷	0.96		CRK564□P-PS□ CRK564□KP-PS□ CRK564APR27PS□ CRK564RKPPS□
90 (3.54)	PK599□E-PS□ PK599AER27PS□		2700×10 ⁻⁷	14.8	5	RK599□E-PS□ RK599A□ER27PS□	
	PK596□E-PS□ PK596AER27PS□		1400×10 ⁻⁷	7.7		RK596□E-PS□ RK596A□ER27PS□	

- Wirings and connections → Page A-288, Encoder specifications → Page A-17
- See the page for the corresponding motor and driver package for speed-torque characteristics and dimensions.
- The dimensions of a motor with an encoder can be found on page A-20.
- Enter the **A** (single shaft) or **B** (double shaft) in the box (□) within the model name.
A number indicating the gear ratio is entered when the box (□) is located within the model name.
Enter the **A** (single-phase 100-115 VAC) or **C** (single-phase 200-230 VAC) in the box (□) with in the model name.
- *CE Marking is applied to a corresponding motor and driver package product.

Gearmotor Specifications

Model • Single Shaft/Double Shaft • with TTL Type Encoder • with Differential Type Encoder	Gear Ratio	Maximum Holding Torque		Basic Step Angle	Backlash arc minute (degrees)	Permissible Speed Range r/min
		N·m	lb·in			
PK566□W-PS5 PK566AWR27PS5 PK566AWR27LPS5	5	3.5	30	0.144°	15 (0.25)	0~600
PK566□W-PS7 PK566AWR27PS7 PK566AWR27LPS7	7.2	4	35	0.1°		0~416
PK566□W-PS10 PK566AWR27PS10 PK566AWR27LPS10	10	5	44	0.072°		0~300
PK564□W-PS25 PK564AWR27PS25 PK564AWR27LPS25	25	8	70	0.0288°		0~120
PK564□W-PS36 PK564AWR27PS36 PK564AWR27LPS36	36			0.02°		0~83
PK564□W-PS50 PK564AWR27PS50 PK564AWR27LPS50	50			0.0144°		0~60
PK599□E-PS5 PK599AER27PS5	5	14	123	0.144°		0~600
PK599□E-PS7 PK599AER27PS7	7.2	20	177	0.1°		0~416
PK599□E-PS10 PK599AER27PS10	10			0.072°		0~300
PK596□E-PS25 PK596AER27PS25	25	37	320	0.0288°		0~120
PK596□E-PS36 PK596AER27PS36	36			0.02°	0~83	
PK596□E-PS50 PK596AER27PS50	50			0.0144°	0~60	

- Enter **A** (single shaft) or **B** (double shaft) in the box (□) within the model name.

Introduction of Stepping Motor and Driver Packages

Stepping motor and driver packages are available. Packages are outfitted with drivers specifically designed to obtain the motor's maximum performance.

AC Input
Motor and Driver Package

RK Series → Page A-78

DC Input
Motor and Driver Package

CRK Series → Page A-168

- 20 mm (0.79 in.)
- 28 mm (1.10 in.)
- 35 mm (1.38 in.)
- 42 mm (1.65 in.)
- 50 mm (1.97 in.)
- 56.4 mm (2.22 in.)
- 60 mm (2.36 in.)
- 85 mm (3.35 in.)
- 90 mm (3.54 in.)

PS Geared Type

Motor Frame Size 28 mm (1.10 in.)

PK Series



Specifications

Motor Specifications (RoHS)

Model • Single Shaft/Double Shaft • with Encoder	Connection Type	Rated Current	Voltage	Resistance	Inductance	Rotor Inertia J		Motor Lead Wires (Pins)	Corresponding Motor & Driver Package
		A/phase	VDC	Ω/phase	mH/phase	kg·m ²	oz·in ²		RBK Series
PK223PD □- PS5	Bipolar	1.5	1.8	1.2	0.74	9×10 ⁻⁷	0.049	4	RBK223P □- P-PS ■
PK223PD □- PS10									

- Wirings and connections → Page A-288
- See the page for the corresponding motor and driver package for speed-torque characteristics and dimensions.
- Enter the **A** (single shaft) or **B** (double shaft) in the box (□) within the model name.
Enter the gear ratio in the box (■) within the model name.

Note

- Direction of rotation of the motor and that of the gear output shaft are the same.

Gearmotor Specifications

Model • Single Shaft/Double Shaft • with Encoder	Gear Ratio	Holding Torque*		Maximum Torque		Basic Step Angle	Backlash arc minute (degrees)	Permissible Speed Range r/min
		N·m	oz·in	N·m	oz·in			
PK223PD □- PS5	5	0.3	42	0.5	71	0.36°	35 (0.59)	600
PK223PD □- PS10	10	0.5	71					300

* Holding torque is the same regardless of the connection type due to the permissible torque limit of the gearhead.

- Enter **A** (single shaft) or **B** (double shaft) in the box (□) within the model name.

Dimensions Unit = mm (in.)

Model	Mass kg (lb.)	DXF
PK223PDA-PS ■	0.11	B975
PK223PDB-PS ■	(0.24)	

- Enter the gear ratio in the box (■) within the model name.
- Lead wires are not supplied with the connector-coupled motor and must be purchased separately.
The connection cable is available as an accessory (sold separately).
- Applicable Connector
Connector housing: 51065-0600 (MOLEX)
Contact: 50212-8100 (MOLEX)
Crimp tool: 57176-5000 (MOLEX)

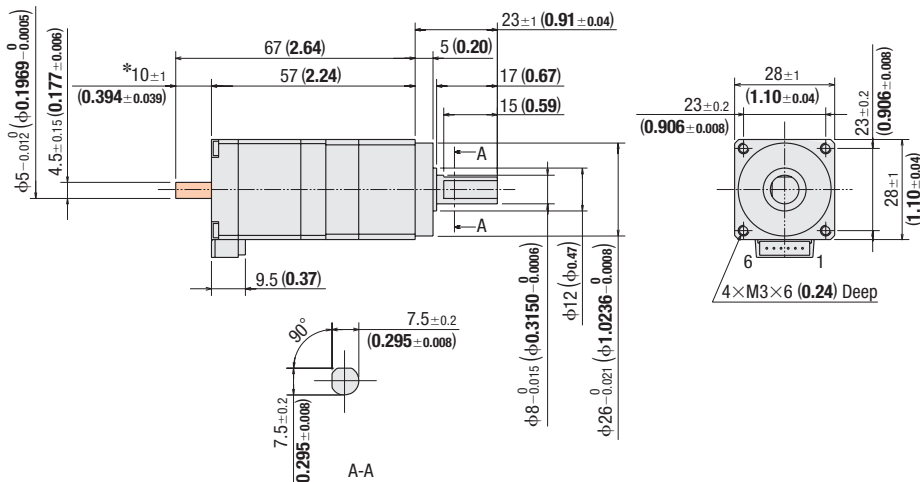

* The length of machining on the double shaft model is 10 ± 0.25 (0.394 ± 0.010).

- These dimensions are for the double shaft models. For the single shaft models, ignore the orange (■) area.

Speed – Torque Characteristics

PK223PD

Bipolar 24 VDC

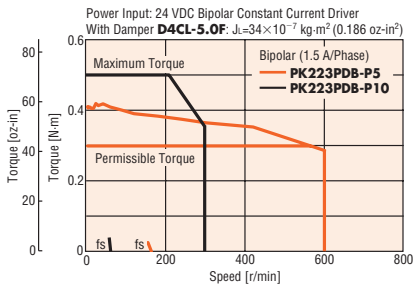

PK223PD

Bipolar 36 VDC

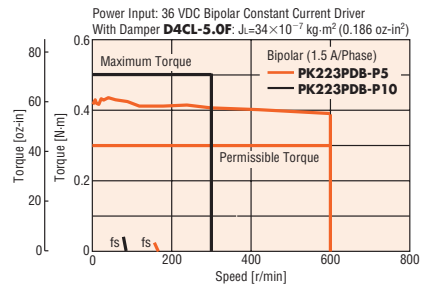

Note

- Pay attention to heat dissipation from motor as there will be a considerable amount of heat under certain conditions. Be sure to keep the temperature of the motor case under 100°C (212°F).

Accessories (Sold separately)

The connection cable is available as an accessory.

- Connection Cable → Page A-409

Introduction	
AR	DC Input Motor & Driver
AR /Geared	0.36° /Geared
AS	0.36° /Geared
AS /Geared	0.36° /Geared
RK	0.72° /Geared
UMK	0.9°/1.8°
AR	DC Input Motor & Driver
AR /Geared	0.36° /Geared
ASX	0.36° /Geared
CRK	0.36°/0.72° /Geared
CMK	0.9°/1.8° /Geared
RBK	1.8° /Geared
PK	Motor Only
PK	0.36°
PK	0.72°
PK	0.9°
PK/PV	1.8°
PK	Geared
SCX10 /EMP400 /SG8030J	Controllers
	Accessories

PL Geared Type

Motor Frame Size 42 mm (1.65 in.)

PK Series



Specifications

Motor Specifications RoHS

Model • Single Shaft/Double Shaft • with Encoder	Connection Type	Rated Current A/phase	Voltage VDC	Resistance Ω /phase	Inductance mH/phase	Rotor Inertia J		Motor Lead Wires (Pins)	Corresponding Motor & Driver Package RBK Series
						kg·m ²	oz·in ²		
PK244PD <input type="checkbox"/> - P5 PK244PDAR <input type="checkbox"/> - P5	Bipolar	1.5	2.14	1.43	1.5	57×10 ⁻⁷	0.31	4	RBK244P <input type="checkbox"/> - P <input type="checkbox"/> RBK244PAR <input type="checkbox"/> - P <input type="checkbox"/>
PK244PD <input type="checkbox"/> - P10 PK244PDAR <input type="checkbox"/> - P10									
PK244PD <input type="checkbox"/> - P36 PK244PDAR <input type="checkbox"/> - P36		1.2	0.8	0.47					

● Wirings and Connections → Page A-288

Encoder Specifications → Page A-17

- Enter **A** (single shaft) or **B** (double shaft) in the box () within the model name.
- Enter the encoder code (**15**, **16**, **25** or **26**) in the box () within the model name.
- Enter the gear ratio in the box () within the model name.
- Product Number Code → Page A-278

Note

- Direction of rotation of the motor and that of the gear output shaft are the same.

Gearmotor Specifications

Model • Single Shaft/Double Shaft • with Encoder	Gear Ratio	Holding Torque*		Basic Step Angle	Backlash arc minute (degrees)	Permissible Speed Range r/min
		N·m	lb·in			
PK244PD <input type="checkbox"/> - P5 PK244PDAR <input type="checkbox"/> - P5	5	1	8.8	0.36°	35 (0.59)	360
PK244PD <input type="checkbox"/> - P10 PK244PDAR <input type="checkbox"/> - P10	10	1.5	13.2	0.18°		180
PK244PD <input type="checkbox"/> - P36 PK244PDAR <input type="checkbox"/> - P36	36	3	26	0.05°		50

*Holding torque is the same regardless of the connection type due to the permissible torque limit of the gearhead.

- Enter **A** (single shaft) or **B** (double shaft) in the box () within the model name.
- Enter the encoder code (**15**, **16**, **25** or **26**) in the box () within the model name.

20 mm
(0.79 in.)

28 mm
(1.10 in.)

35 mm
(1.38 in.)

42 mm
(1.65 in.)

50 mm
(1.97 in.)

56.4 mm
(2.22 in.)

60 mm
(2.36 in.)

85 mm
(3.35 in.)

90 mm
(3.54 in.)

Dimensions Unit = mm (in.)

The dimension of a motor with an encoder can be found on page A-19 or at www.orientalmotor.com.

Model	L1	L2	Mass kg (lb.)	DXF
PK244PDA-P5	66.5 (2.62)	—	0.48 (1.06)	B331
PK244PDB-P5		81.5 (3.21)		
PK244PDA-P10		—		
PK244PDB-P10	81.5 (3.21)			
PK244PDA-P36	90 (3.54)	—	0.6 (1.32)	
PK244PDB-P36		105 (4.13)		

- Lead wire and connector are not supplied with the connector-coupled motor and must be purchased separately. The connection cable is available as an accessory (sold separately).
- Applicable Connector
Connector housing: 51103-0600 (MOLEX)
Contact: 50351-8100 (MOLEX)
Crimp tool: 57295-5000 (MOLEX)

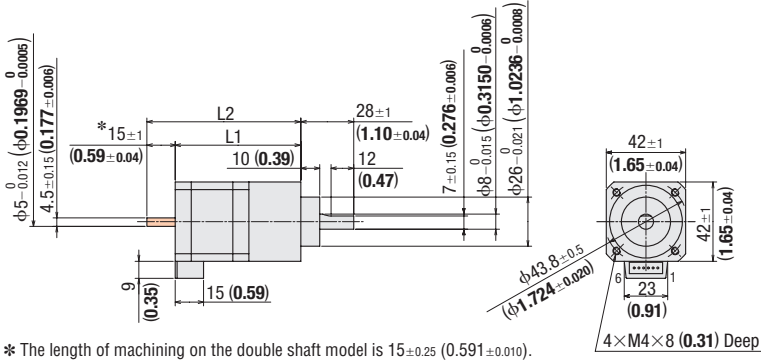

- These dimensions are for the double shaft models. For the single shaft models, ignore the orange () area.

Speed – Torque Characteristics

PK244PD

Bipolar 24 VDC

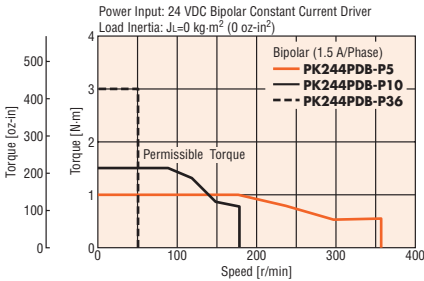

PK244PD

Bipolar 36 VDC

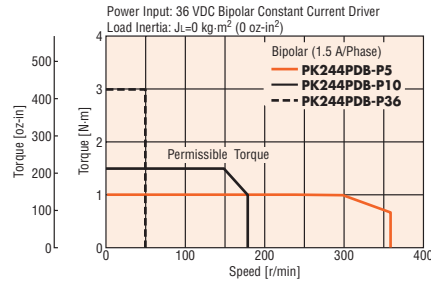

Note

- Pay attention to heat dissipation from motor as there will be a considerable amount of heat under certain conditions. Be sure to keep the temperature of the motor case under 100°C (212°F).

Accessories (Sold separately)

The connection cable is available as an accessory.

- Connection Cable → Page A-409

Introduction	AC Input Motor & Driver	DC Input Motor & Driver	Motor Only	Controllers
AR	0.36° / Geared	0.36° / Geared	PK	SCX10
AS	0.72° / Geared	0.36° / Geared	PK	EMP400
UMK	0.9° / 1.8°	0.36° / Geared	PK	SG8030J
AS	0.36° / Geared	0.36° / Geared	PK	Accessories
ASX	0.36° / Geared	0.36° / Geared	PK / PV	
CRK	0.36° / 0.72° / Geared	0.9° / 1.8° / Geared	PK	
CMK	0.9° / 1.8° / Geared	1.8° / Geared	PK	
RBK	1.8° / Geared		PK	

PL Geared Type

Motor Frame Size 60 mm (2.36 in.)

PK Series



Specifications

Motor Specifications RoHS

Model	Connection Type	Rated Current	Voltage	Resistance	Inductance	Rotor Inertia J		Motor Lead Wires (Pins)	Corresponding Motor & Driver Package
• Single Shaft/Double Shaft • with Encoder		A/phase	VDC	Ω /phase	mH/phase	kg·m ²	oz·in ²		RBK Series
PK266PD <input type="checkbox"/> - P5 PK266PDAR <input type="checkbox"/> - P5	Bipolar	2.8	1.62	0.58	0.97	290×10 ⁻⁷	1.59	4	RBK266P <input type="checkbox"/> - P <input type="checkbox"/> RBK264P <input type="checkbox"/> - P <input type="checkbox"/> RBK266PAR <input type="checkbox"/> - P <input type="checkbox"/> RBK264PAR <input type="checkbox"/> - P <input type="checkbox"/>
PK266PD <input type="checkbox"/> - P10 PK266PDAR <input type="checkbox"/> - P10			1.29	0.46	0.73	120×10 ⁻⁷	0.66		
PK264PD <input type="checkbox"/> - P36 PK264PDAR <input type="checkbox"/> - P36									

● Wirings and Connections → Page A-288

Encoder Specifications → Page A-17

- Enter **A** (single shaft) or **B** (double shaft) in the box () within the model name.
- Enter the encoder code (**15**, **16**, **25** or **26**) in the box () within the model name.
- Enter the gear ratio in the box () within the model name.
- Product Number Code → Page A-278

Note

- Direction of rotation of the motor and that of the gear output shaft are the same.

Gearmotor Specifications

Model	Gear Ratio	Holding Torque*		Basic Step Angle	Backlash	Permissible Speed Range
• Single Shaft/Double Shaft • with Encoder		N·m	lb·in		arc minute (degrees)	r/min
PK266PD <input type="checkbox"/> - P5 PK266PDAR <input type="checkbox"/> - P5	5	3.5	30	0.36°	20 (0.33)	360
PK266PD <input type="checkbox"/> - P10 PK266PDAR <input type="checkbox"/> - P10	10	5	44	0.18°		180
PK264PD <input type="checkbox"/> - P36 PK264PDAR <input type="checkbox"/> - P36	36	8	70	0.05°		50

*Holding torque is the same regardless of the connection type due to the permissible torque limit of the gearhead.

- Enter **A** (single shaft) or **B** (double shaft) in the box () within the model name.
- Enter the encoder code (**15**, **16**, **25** or **26**) in the box () within the model name.

20 mm
(0.79 in.)

28 mm
(1.10 in.)

35 mm
(1.38 in.)

42 mm
(1.65 in.)

50 mm
(1.97 in.)

56.4 mm
(2.22 in.)

60 mm
(2.36 in.)

85 mm
(3.35 in.)

90 mm
(3.54 in.)

20 mm
(0.79 in.)

28 mm
(1.10 in.)

35 mm
(1.38 in.)

42 mm
(1.65 in.)

50 mm
(1.97 in.)

56.4 mm
(2.22 in.)

60 mm
(2.36 in.)

85 mm
(3.35 in.)

90 mm
(3.54 in.)

PN Geared Type

Motor Frame Size 28 mm (1.10 in.), 42 mm (1.65 in.)

PK Series



Specifications

Motor Specifications RoHS



Motor Frame Size mm (in.)	Model •Single Shaft/Double Shaft	Connection Type	Rated Current A/phase	Rotor Inertia J kg-m ² oz-in ²		Motor Lead Wires (Pins)	Corresponding Motor & Driver Package CRK Series (Pulse/Built-in Program)
28 (1.10)	PK523P □-N□	New Pentagon (Bipolar)	0.35	9×10 ⁻⁷	0.049	5	CRK523P □P-N□
42 (1.65)	PK544 □W-N□		0.75	54×10 ⁻⁷	0.3		CRK544 □P-N□

- Wirings and connections → Page A-288
Encoder specifications → Page A-17
- See the page for the corresponding motor and driver package for speed-torque characteristics and dimensions.
- The dimensions of a motor with an encoder can be found on page A-20.
- The motor connection cable is available as an accessory.
- Enter the **A** (single shaft) or **B** (double shaft) in the box (□) within the model name.
Enter the gear ratio in the box (■) within the model name.
Product Number Code → Page A-278
- *1 Adopted for motor frame size 28 mm (1.10 in.) products.
- *2 Adopted for motor frame size 42 mm (1.65 in.) products.
- *3 CE Marking is applied to a corresponding motor and driver package product.

Gearmotor Specifications

Model •Single Shaft/Double Shaft	Gear Ratio	Maximum Holding Torque		Basic Step Angle	Backlash arc minute (degrees)	Permissible Speed Range r/min
		N-m	PK523: oz-in PK544: lb-in			
PK523P □-N5	5	0.2	28	0.144°	3 (0.05)	0~600
PK523P □-N7.2	7.2	0.3	42	0.1°		0~416
PK523P □-N10	10	0.4	56	0.072°		0~300
PK544 □W-N5	5	0.8	7	0.144°	2 (0.034)	0~600
PK544 □W-N7.2	7.2	1.2	10.6	0.1°		0~416
PK544 □W-N10	10	1.5	13.2	0.072°		0~300

- Enter **A** (single shaft) or **B** (double shaft) in the box (□) within the model name.

Introduction of Stepping Motor and Driver Packages

Stepping motor and driver packages are available. Packages are outfitted with drivers specifically designed to obtain the motor's maximum performance.

AC Input Motor and Driver Package

RK Series → Page A-78



DC Input Motor and Driver Package

CRK Series → Page A-168

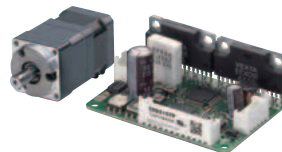

Pulse Input



Built-In Controller

PN Geared Type

Motor Frame Size 60 mm (2.36 in.), 90 mm (3.54 in.)

PK Series

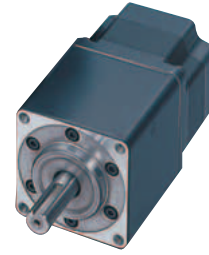

Specifications

Motor Specifications



Motor Frame Size mm (in.)	Model •Single Shaft/Double Shaft	Connection Type	Rated Current A/phase	Rotor Inertia J kg·m ² oz·in ²	Motor Lead Wires (Pins)	Corresponding Motor & Driver Package RK Series CRK Series (Pulse/Built-In Program)
60 (2.36)	PK566□W-N□	New Pentagon (Bipolar)	1.4	280×10 ⁻⁷ 1.53	5	CRK566□P-N□
	PK564□W-N□			175×10 ⁻⁷ 0.96		CRK564□P-N□
90 (3.54)	PK599□E-N□			2700×10 ⁻⁷ 14.8		RK599□E-N□
	PK596□E-N□			1400×10 ⁻⁷ 7.7		RK596□AE-N□

- Wirings and connections → Page A-288
Encoder specifications → Page A-17
- See the page for the corresponding motor and driver package for speed-torque characteristics and dimensions.
- The dimensions of a motor with an encoder can be found on page A-20.
- Enter the **A** (single shaft) or **B** (double shaft) in the box (□) within the model name.
Enter the gear ratio in the box (□) within the model name.
Enter the **A** (single-phase 100-115 VAC) or **C** (single-phase 200-230 VAC) in the box (□) with in the model name.
- *CE Marking is applied to a corresponding motor and driver package product.

Gearmotor Specifications

Model •Single Shaft/Double Shaft	Gear Ratio	Maximum Holding Torque		Basic Step Angle	Backlash arc minute (degrees)	Permissible Speed Range r/min			
		N·m	lb·in						
PK566□W-N5	5	3.5	30	0.144°	2 (0.034)	0~600			
PK566□W-N7.2	7.2	4	35	0.1°		0~416			
PK566□W-N10	10	5	44	0.072°		0~300			
PK564□W-N25	25	8	70	0.0288°	3 (0.05)	0~120			
PK564□W-N36	36			0.02°		0~83			
PK564□W-N50	50			0.0144°		0~60			
PK599□E-N5	5			14		123	0.144°	2 (0.034)	0~600
PK599□E-N7.2	7.2			20		177	0.1°		0~416
PK599□E-N10	10	0.072°	0~300						
PK596□E-N25	25	37	320	0.0288°	3 (0.05)	0~120			
PK596□E-N36	36			0.02°		0~83			
PK596□E-N50	50			0.0144°		0~60			

- Enter **A** (single shaft) or **B** (double shaft) in the box (□) within the model name.

Introduction of Stepping Motor and Driver Packages

Stepping motor and driver packages are available. Packages are outfitted with drivers specifically designed to obtain the motor's maximum performance.

AC Input Motor and Driver Package

RK Series → Page A-78



DC Input Motor and Driver Packages

CRK Series → Page A-168

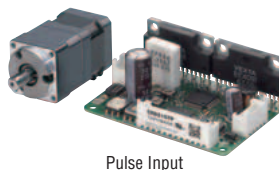

Pulse Input



Built-In Controller

Introduction	AC Input Motor & Driver	DC Input Motor & Driver	Motor Only
AR	0.36° / Geared	0.36° / Geared	PK
AS	0.72° / Geared	0.36° / Geared	PK
ASX	0.9° / 1.8°	0.36° / Geared	PK
AS	0.9° / 1.8°	0.36° / Geared	PK/PV
AS	1.8° / Geared	0.36° / Geared	Geared PK
AS	1.8° / Geared	0.36° / Geared	Controllers SCX10 / EMP400 / SG80301
AS	Accessories		

- 20 mm (0.79 in.)
- 28 mm (1.10 in.)
- 35 mm (1.38 in.)
- 42 mm (1.65 in.)
- 50 mm (1.97 in.)
- 56.4 mm (2.22 in.)
- 60 mm (2.36 in.)
- 85 mm (3.35 in.)
- 90 mm (3.54 in.)

Harmonic Geared Type

Motor Frame Size 20 mm (0.79 in.), 30 mm (1.18 in.), 42 mm (1.65 in.)

PK Series



Specifications

Motor Specifications (RoHS)



Motor Frame Size mm (in.)	Model • Single Shaft/Double Shaft • with Encoder	Connection Type	Rated Current A/phase	Rotor Inertia J		Motor Lead Wires (Pins)	Corresponding Motor & Driver Package
				kg·m ²	oz·in ²		CRK Series (Pulse/Built-in Program)
20 (0.79)	PK513P□-H□S	New Pentagon (Bipolar)	0.35	2.1 × 10 ⁻⁷	0.0115	5	CRK513P□P-H□ CRK513P□KP-H□
30 (1.18)	PK523HP□-H□S			12 × 10 ⁻⁷	0.066		CRK523P□P-H□ CRK523P□KP-H□
42 (1.65)	PK543□W-H□S PK543AWR27H□ PK543AWR27LH□		0.75	52 × 10 ⁻⁷	0.28		CRK543□P-H□ CRK543□KP-H□ CRK543APR27H□ CRK543RKP-H□

- Wirings and connections → Page A-288
Encoder specifications → Page A-17
- See the page for the corresponding motor and driver package for speed-torque characteristics and dimensions.
- The dimensions of a motor with an encoder can be found on page A-20.
- Enter the **A** (single shaft) or **B** (double shaft) in the box (□) within the model name.
Enter the gear ratio in the box (■) within the model name.
- *1 Adopted for motor frame size 20 mm (0.79 in.) and 28 mm (1.10 in.) products.
- *2 Adopted for motor frame size 42 mm (1.65 in.) products.
- *3 CE Marking is applied to a corresponding motor and driver package product.

Gearmotor Specifications

Model • Single Shaft/Double Shaft	• with TTL Type Encoder • with Differential Type Encoder	Gear Ratio	Maximum Holding Torque		Basic Step Angle	Lost Motion (Load torque) arc minute (degrees)	Permissible Speed Range r/min
			N·m	lb·in			
PK513P□-H50S	—	50	0.4	3.5	0.0144°	2 max. (±0.02 N·m)	0~90
PK513P□-H100S	—	100	0.6	5.3	0.0072°	2 max. (±0.03 N·m)	0~45
PK523HP□-H50S	—	50	1.8	15.9	0.0144°	1.5 max. (±0.09 N·m)	0~70
PK523HP□-H100S	—	100	2.4	21	0.0072°	1.5 max. (±0.12 N·m)	0~35
PK543□W-H50S	PK543AWR27H50 PK543AWR27LH50	50	3.5	30	0.0144°	1.5 max. (±0.16 N·m)	0~70
PK543□W-H100S	PK543AWR27H100 PK543AWR27LH100	100	5	44	0.0072°	1.5 max. (±0.2 N·m)	0~35

- Enter **A** (single shaft) or **B** (double shaft) in the box (□) within the model name.

Introduction of Stepping Motor and Driver Packages

Stepping motor and driver packages are available. Packages are outfitted with drivers specifically designed to obtain the motor's maximum performance.

AC Input Motor and Driver Package

RK Series → Page A-78



DC Input Motor and Driver Package

CRK Series → Page A-168

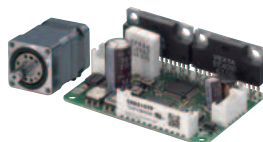

Pulse Input



Built-In Controller

Harmonic Geared Type

Motor Frame Size 60 mm (2.36 in.), 90 mm (3.54 in.)

PK Series



Specifications

Motor Specifications



Motor Frame Size mm (in.)	Model • Single Shaft/Double Shaft • with Encoder	Connection Type	Rated Current A/phase	Rotor Inertia J kg-m ² oz-in ²	Motor Lead Wires (Pins)	Corresponding Motor & Driver Package RK Series CRK Series (Pulse/Built-In Program)
60 (2.36)	PK564 <input type="checkbox"/> W-H <input type="checkbox"/> S PK564AWR27H <input type="checkbox"/> PK564AWR27LH <input type="checkbox"/>	New Pentagon (Bipolar)	1.4	210×10 ⁻⁷ 1.15	5	CRK564 <input type="checkbox"/> P-H <input type="checkbox"/> CRK564 <input type="checkbox"/> KP-H <input type="checkbox"/> CRK564APR27H <input type="checkbox"/> CRK564RKPH <input type="checkbox"/>
90 (3.54)	PK596 <input type="checkbox"/> E1-H <input type="checkbox"/> PK596AE1R27H <input type="checkbox"/>			1600×10 ⁻⁷ 8.8		RK596 <input type="checkbox"/> E-PS <input type="checkbox"/> RK596A <input type="checkbox"/> ER27PS <input type="checkbox"/>

- Wirings and connections → Page A-288
Encoder specifications → Page A-17
 - See the page for the corresponding motor and driver package for speed-torque characteristics and dimensions.
 - The dimensions of a motor with an encoder can be found on page A-20.
 - Enter the **A** (single shaft) or **B** (double shaft) in the box () within the model name.
Enter the gear ratio in the box () within the model name.
 - Enter the **A** (single-phase 100-115 VAC) or **C** (single-phase 200-230 VAC) in the box () with in the model name.
- *CE Marking is applied to a corresponding motor and driver package product.

Gearmotor Specifications

Model • Single Shaft/Double Shaft		Gear Ratio	Maximum Holding Torque		Basic Step Angle	Lost Motion (Load torque) arc minute (degrees)	Permissible Speed Range r/min
	• with TTL Type Encoder • with Differential Type Encoder		N-m	lb-in			
PK564 <input type="checkbox"/> W-H <input type="checkbox"/> 50S	PK564AWR27H50 PK564AWR27LH50	50	5.5	48	0.0144°	0.7 max. (±0.28 N-m)	0~70
PK564 <input type="checkbox"/> W-H <input type="checkbox"/> 100S	PK564AWR27H100 PK564AWR27LH100	100	8	70	0.0072°	0.7 max. (±0.39 N-m)	0~35
PK596 <input type="checkbox"/> E1-H <input type="checkbox"/> 50	PK596AE1R27H50	50	25	220	0.0144°	1.5 max. (±1.2 N-m)	0~70
PK596 <input type="checkbox"/> E1-H <input type="checkbox"/> 100	PK596AE1R27H100	100	37	320	0.0072°		0~35

- Enter **A** (single shaft) or **B** (double shaft) in the box () within the model name.

Introduction of Stepping Motor and Driver Packages

Stepping motor and driver packages are available. Packages are outfitted with drivers specifically designed to obtain the motor's maximum performance.

AC Input Motor and Driver Package

RK Series → Page A-78



DC Input Motor and Driver Package

CRK Series → Page A-168

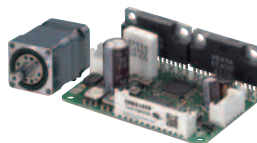

Pulse Input



Built-In Controller

Introduction	AC Input Motor & Driver	DC Input Motor & Driver	Motor Only	Controllers	Accessories
AR	AS	ASX	PK	SCX10	
Geared	Geared	Geared	Geared	EMP400	
0.36°	0.72°	0.36°	0.36°	5G8030J	
0.9°/1.8°	0.9°/1.8°	0.9°/1.8°	0.72°		
UMK	UMK	CRK	0.9°		
AR	AR	CMK	1.8°		
0.36°	0.36°	RBK	Geared		
0.36°	0.36°	PK	1.8°		
0.36°	0.36°	PK	PK/PV		
0.36°	0.36°	PK	Geared		
0.36°	0.36°	PK	Geared		

General Specifications

Item	Motor	
Thermal Class	130 (B) [Step angle 1.8° Standard type terminal box: Recognized as Class 105 (A) by UL/CSA Standards]	
Insulation Resistance	100MΩ or more when 500 VDC megger is applied between the windings and the case under normal ambient temperature and humidity.	
Dielectric Strength	<ul style="list-style-type: none"> ● Step Angle 0.36°/0.72° Stepping Motors Sufficient to withstand 1.5 kVAC at 60Hz applied between the windings and the case for 1 minute, under normal ambient temperature and humidity. 0.5 kVAC: PK51, PK52, PK54PM, PK54P 1.0 kVAC: PK54, PK56PM ● Step Angle 0.9°/1.8° Stepping Motors Sufficient to withstand 1.5 kVAC at 60Hz applied between the windings and the case for 1 minute, under normal ambient temperature and humidity. 0.5 kVAC: PK223, PK24 	
Operating Environment	Ambient Temperature	-10~+50°C (+14~+122°F) (non-freezing) 0~+40°C (+32~+104°F) (non-freezing): Harmonic geared type
	Ambient Humidity	85% or less (non-condensing)
	Atmosphere	No corrosive gasses, dust, water or oil (Standard type terminal box: no corrosive gasses and oil)
Temperature Rise	Temperature rise of windings is 80°C (144°F) or less measured by the resistance change method. (at rated voltage, at standstill, two phases excited)	
Stop Position Accuracy*1	<ul style="list-style-type: none"> ±3 arc minutes (±0.05°): PK Series ±10 arc minutes (±0.17°): PK513 ±2 arc minutes (±0.034°): Step angle 0.36° High-torque type, PV Series ±5 arc minutes (±0.083°): PK213P 	
Shaft Runout	0.05 mm (0.002 in.) T.I.R.*4	
Radial Play*2	0.025 mm (0.001 in.) maximum of 5 N (1.12 lb.)	
Axial Play*3	0.075 mm (0.003 in.) maximum of 10 N (2.2 lb.)	
Concentricity	0.075 mm (0.003 in.) T.I.R.*4	
Perpendicularity	0.075 mm (0.003 in.) T.I.R.*4	

*1 This value is for full step under no load. (The value changes with the size of the load.)

*2 Radial Play: Displacement in shaft position in the radial direction, when a 5 N (1.12 lb.) load is applied in the vertical direction to the tip of the motor's shaft.

*3 Axial Play: Displacement in shaft position in the axial direction, when a 10 N (2.2 lb.) load is applied to the motor's shaft in the axial direction.

*4 T.I.R. (Total Indicator Reading): The total dial gauge reading when the measurement section is rotated one revolution centered on the reference axis center.

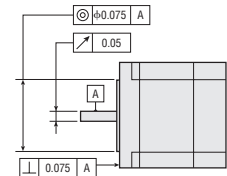

Encoder Overhung Load and Permissible Thrust Load

→ Page A-15

Encoder Specifications

→ Page A-17