

Unipolar 1.8° and 0.9° Stepper Motors **PKP Series** with Encoders

Introducing the new 1.8° Standard and 0.9° High Resolution **PKP** Series stepper motors with an incremental Line Driver or Voltage output type encoder pre-assembled.

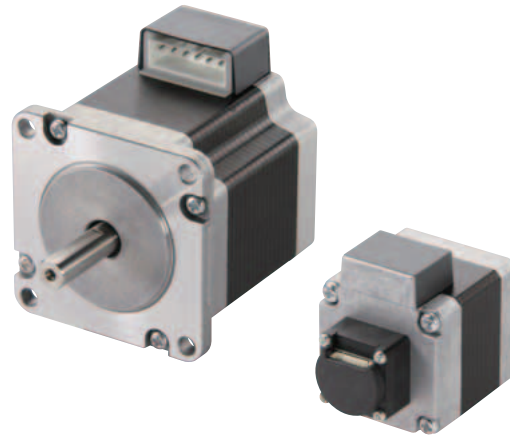

Features

● Motor position information detection is possible

Current position monitoring and position gap detection are possible by using an encoder type motor. For example, normal motor operation can be confirmed by comparing the current position and the command position.

● Compact Encoder

Contributing to overall space savings, the **PKP** Series features a standard size, compact encoder.

- Example of a 42 mm (1.65 in.)

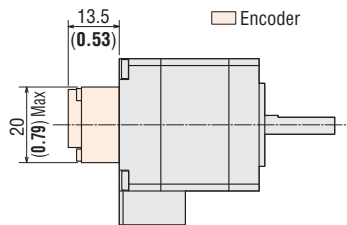

● To reduce electrical noise, use the Line Driver Output type

The Line Driver output offers excellent noise resistance because of the differential output and is capable of longer wiring distance compared to the voltage output.

● Main Specifications of Encoders

- Output Circuit Format: Line Driver Output or Voltage Output type
- Resolution: 200P/R (Standard Type), 400P/R (High-Resolution Type)
- Output Signal: A-Phase, B-Phase, Z-Phase (3ch)

Product Lineup

Type	Connection Method	Frame Size				
		20 mm (0.79 in.)	28 mm (1.10 in.)	35 mm (1.38 in.)	42 mm (1.65 in.)	56.4 mm (2.22 in.)
Standard type Basic step angle: 1.8° Encoder resolution: 200 P/R	Bipolar	●	●	●	●	●
	Unipolar*	●	●	●	●	●
High-resolution type Basic step angle: 0.9° Encoder resolution: 400 P/R	Bipolar	—	—	—	●	●
	Unipolar*	—	—	—	●	●

*See website for part number and specifications

System Configuration

These accessories allow 1.8°/0.9° stepper motors to be used for various operations.

*Not supplied

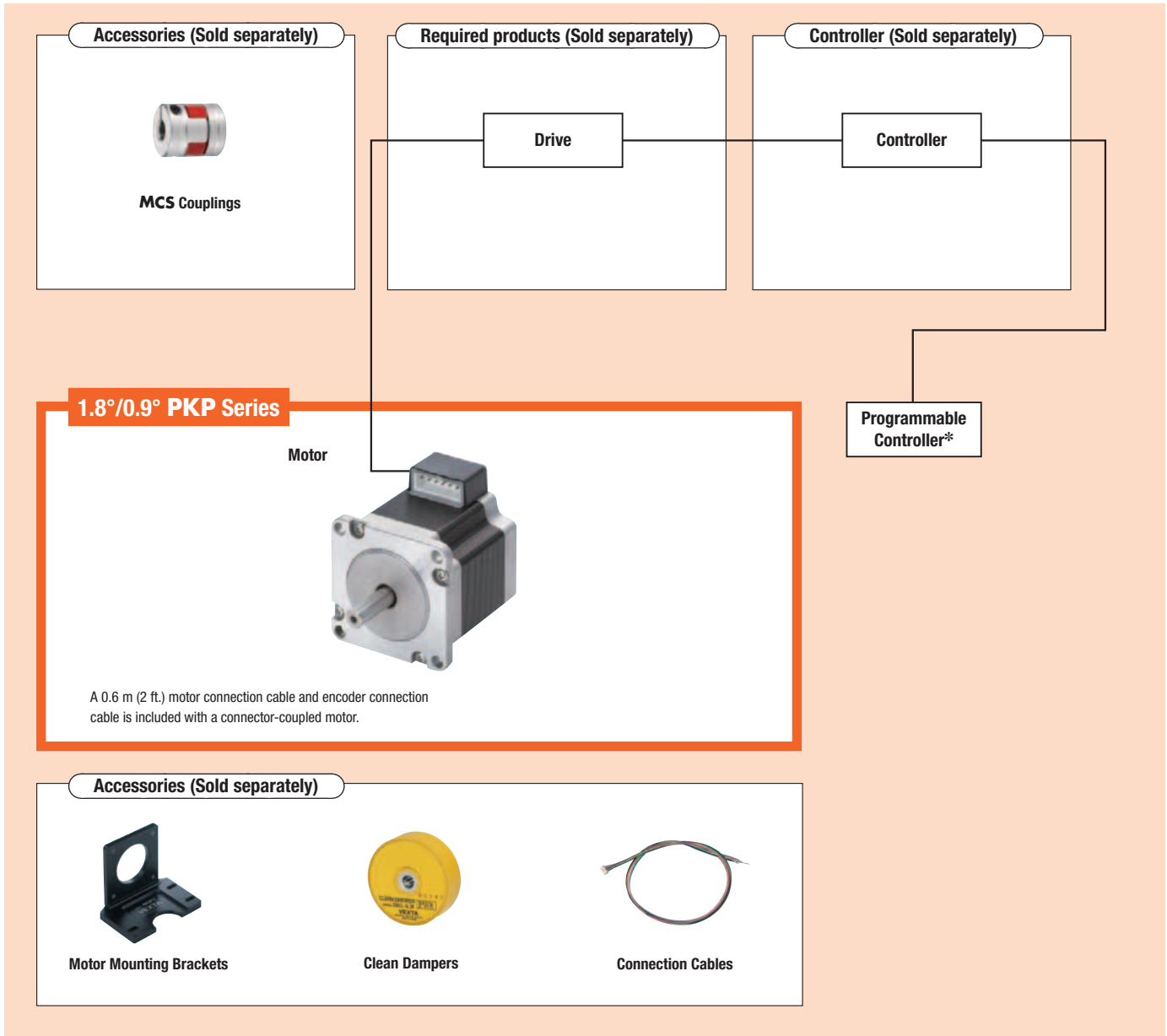

● The system configuration shown above is an example. Other combinations are also available.

Product Number

PKP 2 4 3 M D 15 A - R2F L - L

① ② ③ ④ ⑤ ⑥ ⑦ ⑧ ⑨ ⑩ ⑪

①	Series Name	PKP: PKP Series
②	2-Phase	
③	Motor Frame Size	1: 20 mm (0.79 in.) 2: 28 mm (1.10 in.) 3: 35 mm (1.38 in.) 4: 42 mm (1.65 in.) 6: 56.4 mm (2.22 in.)
④	Motor Case Length	
⑤	Motor Type	Blank: Standard Type M: High-Resolution Type
⑥	Number of Lead Wires	D: 4 U: 5 or 6
⑦	Winding Specification	
⑧	Motor Shaft Configuration	A: Single Shaft A2: 28 mm (1.10 in.)
⑨	Encoder Resolution	R2E: 200P/R R2F: 400P/R
⑩	Encoder Output Circuit Type	L: Line Driver Output Blank: Voltage Output
⑪	Connection Cable	

Product Line

1.8° PKP Series – Line Driver Type

Product Name	List Price
PKP213U05A-R2EL-L	\$148.00
PKP214U06A-R2EL-L	\$155.00
PKP223U09A2-R2EL-L	\$123.00
PKP225U09A2-R2EL-L	\$133.00
PKP233U12A-R2EL-L	\$123.00
PKP235U12A-R2EL-L	\$130.00
PKP243U09A-R2EL-L	\$123.00
PKP244U12A-R2EL-L	\$124.00
PKP245U12A-R2EL-L	\$130.00
PKP246U12A-R2EL-L	\$132.00
PKP264U20A-R2EL-L	\$131.00
PKP266U20A-R2EL-L	\$137.00
PKP268U20A-R2EL-L	\$153.00

0.9° PKP Series – Line Driver Type

Product Name	List Price
PKP243MU09A-R2FL-L	\$133.00
PKP244MU12A-R2FL-L	\$134.00
PKP264MU20A-R2FL-L	\$131.00
PKP266MU20A-R2FL-L	\$137.00
PKP268MU20A-R2FL-L	\$153.00

1.8° PKP Series – Voltage Type

Product Name	List Price
PKP213U05A-R2E-L	\$148.00
PKP214U06A-R2E-L	\$155.00
PKP223U09A2-R2E-L	\$123.00
PKP225U09A2-R2E-L	\$133.00
PKP233U12A-R2E-L	\$123.00
PKP235U12A-R2E-L	\$130.00
PKP243U09A-R2E-L	\$123.00
PKP244U12A-R2E-L	\$124.00
PKP245U12A-R2E-L	\$130.00
PKP246U12A-R2E-L	\$132.00
PKP264U20A-R2E-L	\$131.00
PKP266U20A-R2E-L	\$137.00
PKP268U20A-R2E-L	\$153.00

0.9° PKP Series – Voltage Type

Product Name	List Price
PKP243MU09A-R2F-L	\$133.00
PKP244MU12A-R2F-L	\$134.00
PKP264MU20A-R2F-L	\$131.00
PKP266MU20A-R2F-L	\$137.00
PKP268MU20A-R2F-L	\$153.00

The following items are included with each product.

Motor, Motor Connection Cable*, Encoder Connection Cable, Operating Manual

*Except for motor frame size of 20 mm (0.79 in.).

Step Angle 1.8° Frame Size 20 mm (0.79 in.) Unipolar 5 Lead Wires

Specifications

Product Name	Holding Torque N·m (oz·in)	Rated Current A/phase	Voltage VDC	Resistance Ω/phase	Inductance mH/phase	Rotor Inertia J kg·m ² (oz·in ²)	Lead Wires
PKP213U05A-R2E □-L	0.014 (1.98)	0.5	4.25	8.5	2.9	1.66 × 10 ⁻⁷ (0.0088)	5
PKP214U06A-R2E □-L	0.026 (3.6)	0.6	4.2	7	2.4	2.96 × 10 ⁻⁷ (0.0159)	

● Enter the encoder type (**L** for Line Driver output, **blank** for Voltage output) in the box (□) within the product name.

Speed – Torque Characteristics fs: Max. starting frequency

PKP213U05

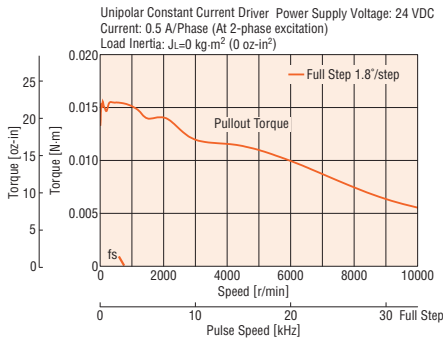

PKP214U06

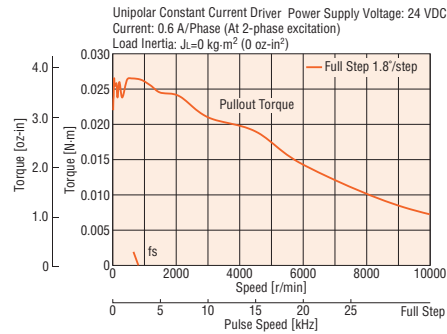

Note

● Depending on the driving conditions, a considerable amount of heat may be generated by the motor. Be sure to keep the temperature of the motor case under 100°C (212°F).

Dimensions Unit = mm (in.)

● Motor with Encoder

2D CAD

Product Name	Motor Product Name	L	Mass kg (lb.)	2D CAD
PKP213U05A-R2E □-L	PKP213U05A-R2E□	46.5 (1.83)	0.06 (0.132)	B1100
PKP214U06A-R2E □-L	PKP214U06A-R2E□	56.5 (2.22)	0.08 (0.176)	B1101

● Applicable Connector (Molex)

	Encoder
Connector Housing	51021-0800
Contact	50079-8100
Crimp Tool	57067-3000

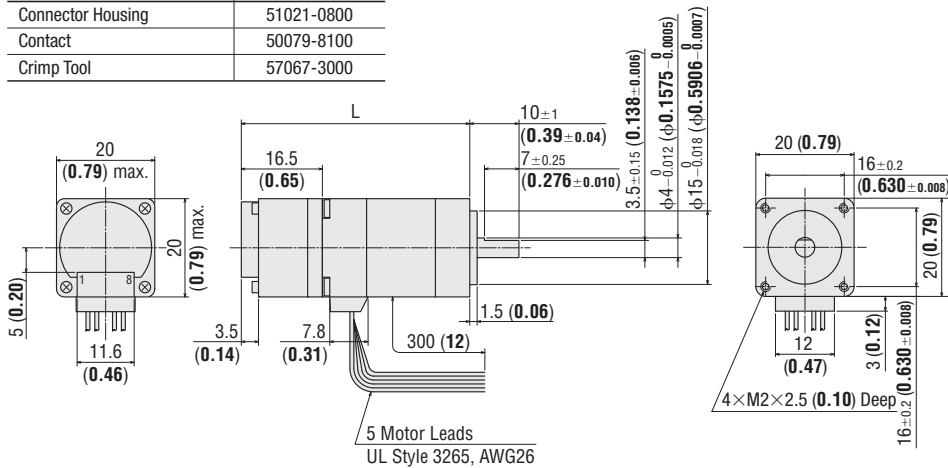

● Included

Connection cable for encoder

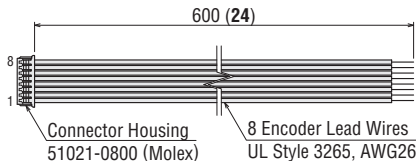

Step Angle 1.8° Frame size 28 mm (1.10 in.) Unipolar 6 Lead Wires

Specifications

Product Name	Holding Torque N·m (oz·in)	Rated Current A/phase	Voltage VDC	Resistance Ω/phase	Inductance mH/phase	Rotor Inertia J kg·m ² (oz·in ²)	Lead Wires
PKP223U09A2-R2E□-L	0.075 (10.6)	0.95	2.95	3.11	1.44	9×10 ⁻⁷ (0.049)	6
PKP225U09A2-R2E□-L	0.135 (19.1)		4.4	4.6	2.11	18×10 ⁻⁷ (0.098)	

- Enter the encoder type (**L** for Line Driver output, **blank** for Voltage output) in the box (□) within the product name.
- A motor connection cable 0.6 m (2 ft.) and encoder connection cable 0.6 m (2 ft.) are included with each product.

Speed – Torque Characteristics fs: Max. starting frequency

PKP223U09

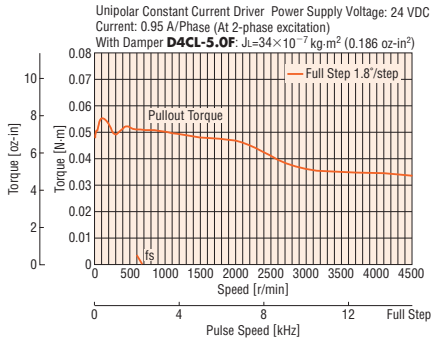

PKP225U09

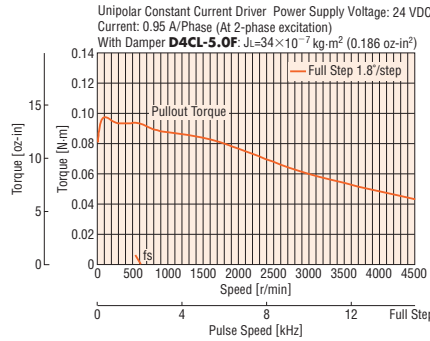

Note

- Speed – Torque Characteristics are data that depends on the measurement conditions of the company. If the conditions are changed, the characteristics may change.
- Speed – Torque Characteristics are data from when external load inertia is used.
- Depending on the driving conditions, a considerable amount of heat may be generated by the motor. Be sure to keep the motor case temperature at 85°C (185°F) max. in order to protect the encoder.

Dimensions Unit = mm (in.)

2D & 3D CAD

Product Name	Motor Product Name	L	Mass kg (lb.)	2D CAD
PKP223U09A2-R2E□-L	PKP223U09A2-R2E□	47.5 (1.87)	0.12 (0.26)	B1198
PKP225U09A2-R2E□-L	PKP225U09A2-R2E□	67 (2.64)	0.21 (0.46)	B1199

- Applicable connector (Molex)

	Motor	Encoder
Connector Housing	51065-0600	51021-0800
Contact	50212-8100	50079-8100
Crimp Tool	57176-5000	57067-3000

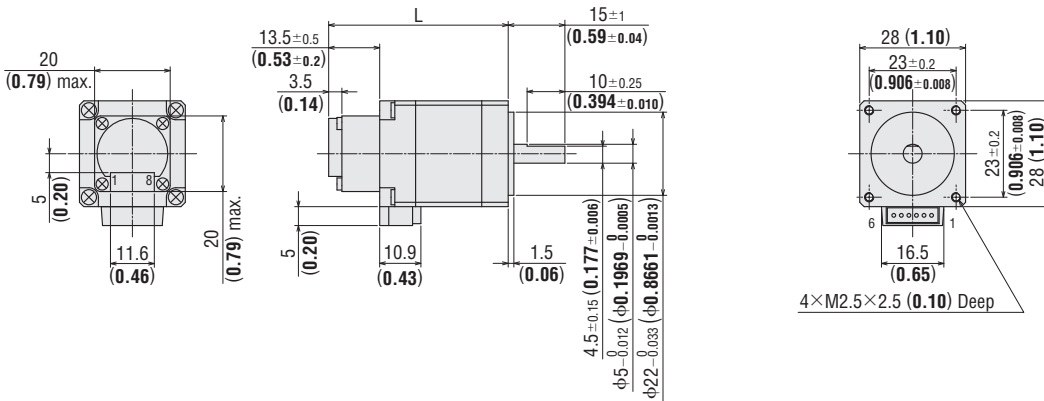

- Included
Connection cable
Product Name: **LC2U06A**

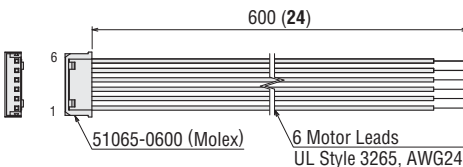

- Included
Encoder connection cable

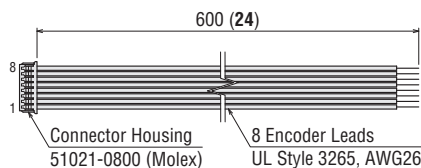

Step Angle 1.8° Frame size 35 mm (1.38 in.) Unipolar 6 Lead Wires

Specifications

Product Name	Holding Torque N·m (oz·in)	Rated Current A/phase	Voltage VDC	Resistance Ω/phase	Inductance mH/phase	Rotor Inertia J kg·m ² (oz·in ²)	Lead Wires
PKP233U12A-R2E <input type="checkbox"/> -L	0.16 (22)	1.2	3.24	2.7	1.4	24 × 10 ⁻⁷ (0.131)	6
PKP235U12A-R2E <input type="checkbox"/> -L	0.3 (42)		4.08	3.4	2	50 × 10 ⁻⁷ (0.27)	

- Enter the encoder type (**L** for Line Driver output, **blank** for Voltage output) in the box () within the product name.
- A motor connection cable 0.6 m (2 ft.) and encoder connection cable 0.6 m (2 ft.) are included with each product.

Speed – Torque Characteristics fs: Max. starting frequency

PKP233U12

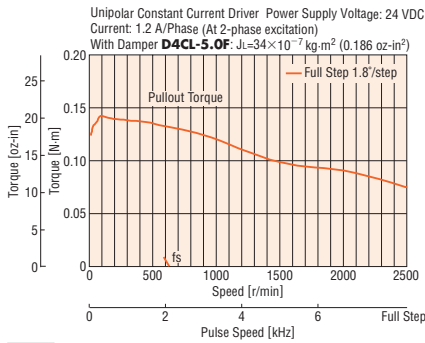

PKP235U12

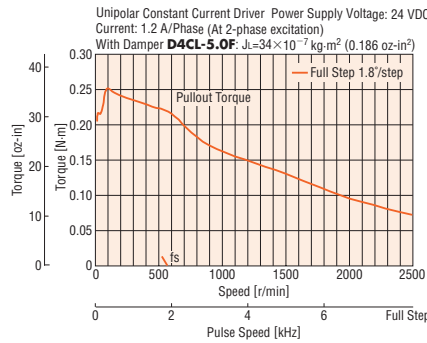

Note

- Depending on the driving conditions, a considerable amount of heat may be generated by the motor. Be sure to keep the motor case temperature at 85°C (185°F) max. in order to protect the encoder.

Dimensions Unit = mm (in.)

Product Name	Motor Product Name	L	Mass kg (lb.)	CAD
PKP233U12A-R2E <input type="checkbox"/> -L	PKP233U12A-R2E <input type="checkbox"/>	50.5 (1.99)	0.19 (0.42)	B1102
PKP235U12A-R2E <input type="checkbox"/> -L	PKP235U12A-R2E <input type="checkbox"/>	65.5 (2.57)	0.295 (0.65)	B1103

- Applicable Connector (Molex)

	Motor	Encoder
Connector Housing	51103-0600	51021-0800
Contact	50351-8100	50079-8100
Crimp Tool	57295-5000	57067-3000

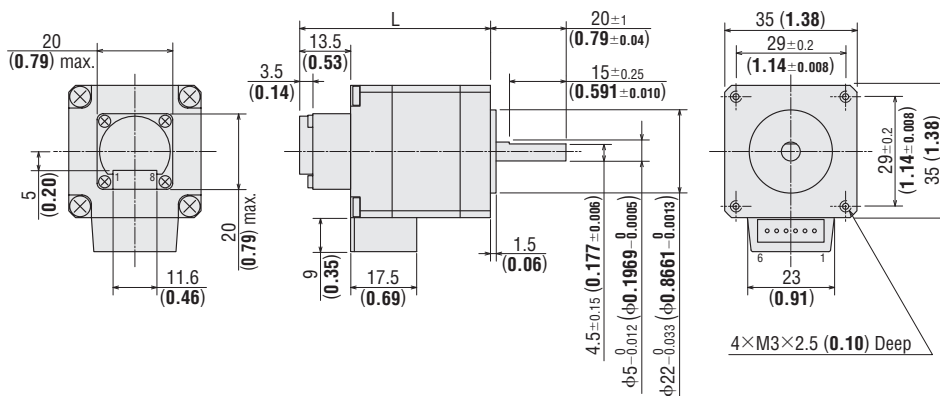

- Included

Motor connection cable
Product Name: **LC2U06B**

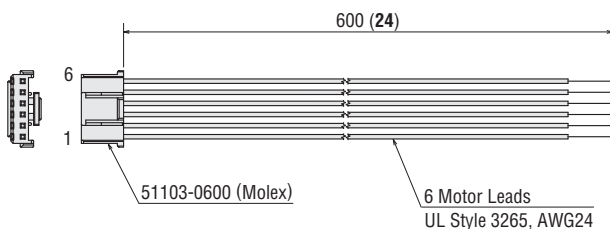

- Included

Encoder connection cable

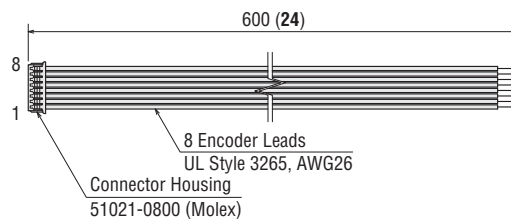

Step Angle 1.8° Frame size 42 mm (1.65 in.) Unipolar 6 Lead Wires

Specifications

Product Name	Holding Torque N·m (oz-in)	Rated Current A/phase	Voltage VDC	Resistance Ω/phase	Inductance mH/phase	Rotor Inertia J kg·m ² (oz-in ²)	Lead Wires
PKP243U09A-R2E □-L	0.25 (35)	0.95	4.47	4.7	5	36×10^{-7} (0.197)	6
PKP244U12A-R2E □-L	0.39 (55)	1.2	4.8	4	3.9	57×10^{-7} (0.31)	
PKP245U12A-R2E □-L	0.45 (63)	1.2	4.56	3.8	5	83×10^{-7} (0.45)	
PKP246U12A-R2E □-L	0.75 (106)	1.2	7.2	6	6.5	114×10^{-7} (0.62)	

- Enter the encoder type (**L** for Line Driver output, **blank** for Voltage output) in the box (□) within the product name.
- A motor connection cable 0.6 m (2 ft.) and encoder connection cable 0.6 m (2 ft.) are included with each product.

Speed – Torque Characteristics fs: Max. starting frequency

PKP243U09

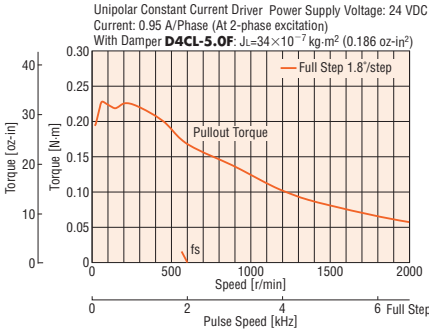

PKP244U12

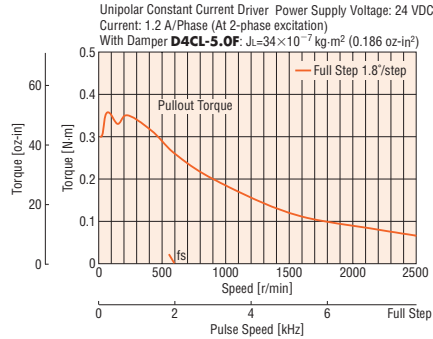

PKP245U12

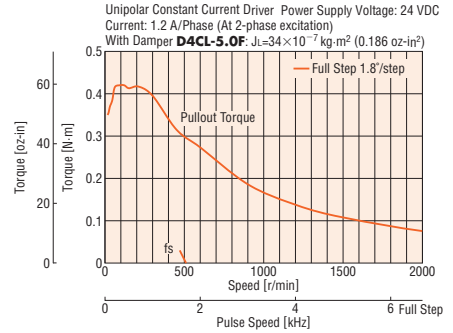

PKP246U12

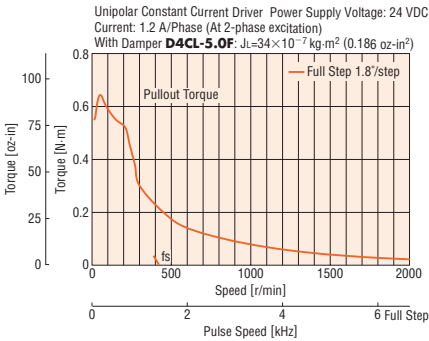

Note

- Depending on the driving conditions, a considerable amount of heat may be generated by the motor. Be sure to keep the motor case temperature at 85°C (185°F) max. in order to protect the encoder.

Dimensions Unit = mm (in.)

Product Name	Motor Product Name	L	Mass kg (lb.)	CAD
PKP243U09A-R2E □-L	PKP243U09A-R2E□	46.5 (1.83)	0.26 (0.57)	B1104
PKP244U12A-R2E □-L	PKP244U12A-R2E□	52.5 (2.07)	0.31 (0.68)	B1105
PKP245U12A-R2E □-L	PKP245U12A-R2E□	60.5 (2.33)	0.40 (0.88)	B1106
PKP246U12A-R2E □-L	PKP246U12A-R2E□	72.5 (2.85)	0.51 (1.12)	B1107

- Applicable Connector (Molex)

	Motor	Encoder
Connector Housing	51103-0600	51021-0800
Contact	50351-8100	50079-8100
Crimp Tool	57295-5000	57067-3000

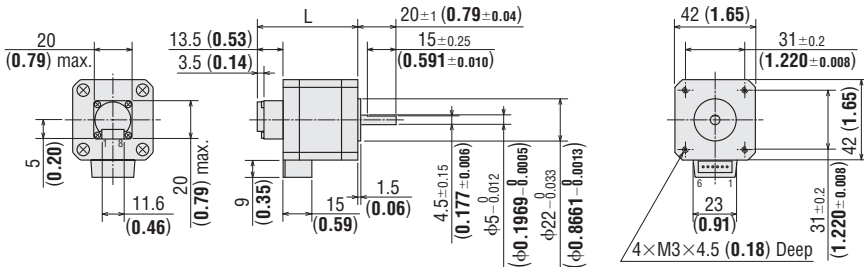

- Included Motor connection cable Product Name: **LC2U06B**

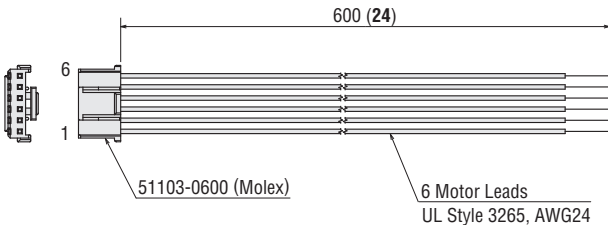

- Included Encoder connection cable

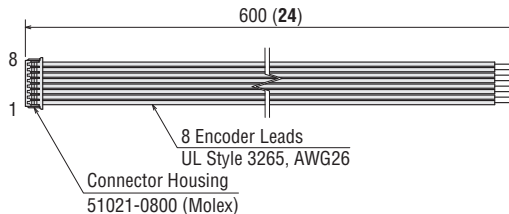

Step Angle 1.8° Frame size 56.4 mm (2.22 in.) Unipolar 6 Lead Wires

Specifications

Product Name	Holding Torque N·m (oz·in)	Rated Current A/phase	Voltage VDC	Resistance Ω/phase	Inductance mH/phase	Rotor Inertia J kg·m ² (oz·in ²)	Lead Wires
PKP264U20A-R2E □-L	0.51 (72)	2	2.9	1.45	1.8	120×10 ⁻⁷ (0.66)	6
PKP266U20A-R2E □-L	1.1 (156)		4	2	2.9	290×10 ⁻⁷ (1.59)	
PKP268U20A-R2E □-L	1.75 (240)		4.9	2.45	4.4	490×10 ⁻⁷ (2.7)	

- Enter the encoder type (**L** for Line Driver output, **blank** for Voltage output) in the box (□) within the product name.
- A motor connection cable 0.6 m (2 ft.) and encoder connection cable 0.6 m (2 ft.) are included with each product.

Speed – Torque Characteristics fs: Max. starting frequency

PKP264U20

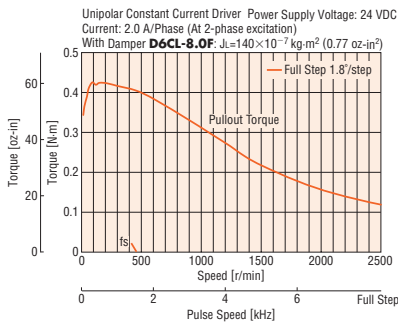

PKP266U20

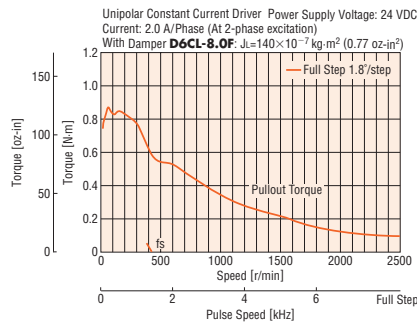

PKP268U20

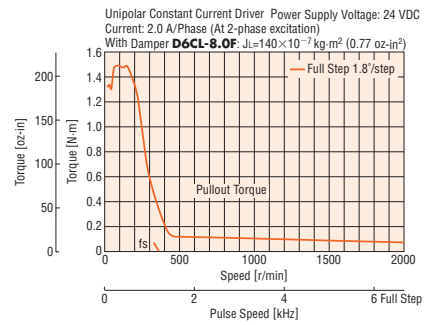

Note

- Depending on the driving conditions, a considerable amount of heat may be generated by the motor. Be sure to keep the motor case temperature at 85°C (185°F) max. in order to protect the encoder.

Dimensions Unit = mm (in.)

Product Name	Motor Product Name	L	Mass kg (lb.)	CAD
PKP264U20A-R2E □-L	PKP264U20A-R2E□	55.5 (2.19)	0.47 (1.04)	B1108
PKP266U20A-R2E □-L	PKP266U20A-R2E□	70.5 (2.78)	0.74 (1.63)	B1109
PKP268U20A-R2E □-L	PKP268U20A-R2E□	92.5 (3.64)	1.11 (2.45)	B1110

- Applicable Connector (Molex)

	Motor	Encoder
Connector Housing	51067-0600	51021-0800
Contact	50217-9101	50079-8100
Crimp Tool	57189-5000 57190-5000	57067-3000

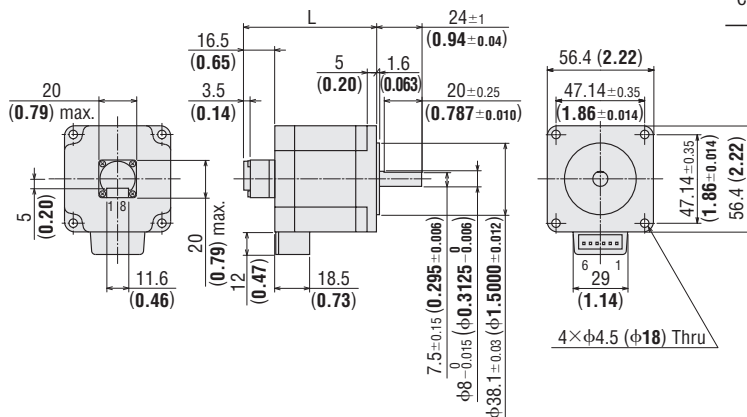

- Included
Motor connection cable
Product Name: **LC2U06C**

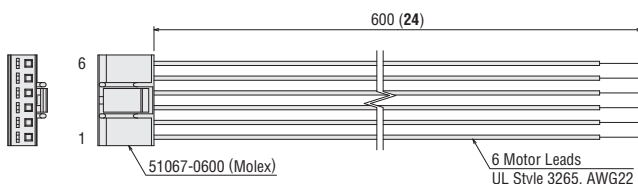

- Included
Encoder connection cable

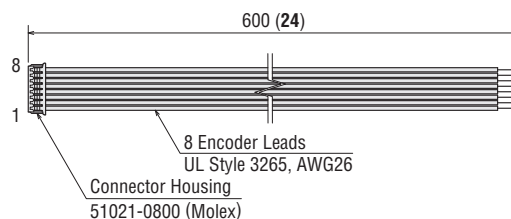

Step Angle 0.9° Frame size 42 mm (1.65 in.) Unipolar 6 Lead Wires

Specifications

Product Name	Holding Torque N·m (oz·in)	Rated Current A/phase	Voltage VDC	Resistance Ω/phase	Inductance mH/phase	Rotor Inertia J kg·m ² (oz·in ²)	Lead Wires
PKP243MU09A-R2E □-L	0.25 (35)	0.95	4.47	4.7	6.6	36×10^{-7} (0.197)	6
PKP244MU12A-R2E □-L	0.35 (49)	1.2	4.8	4	6	57×10^{-7} (0.31)	

- Enter the encoder type (**L** for Line Driver output, **blank** for Voltage output) in the box (□) within the product name.
- A motor connection cable 0.6 m (2 ft.) and encoder connection cable 0.6 m (2 ft.) are included with each product.

Speed – Torque Characteristics fs: Max. starting frequency

PKP243MU09

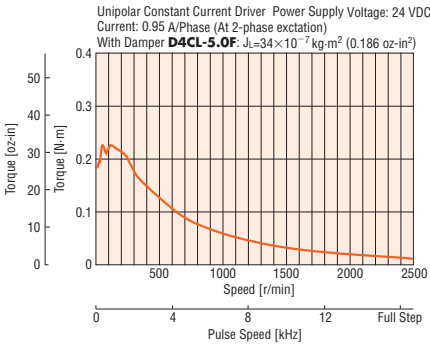

PKP244MU12

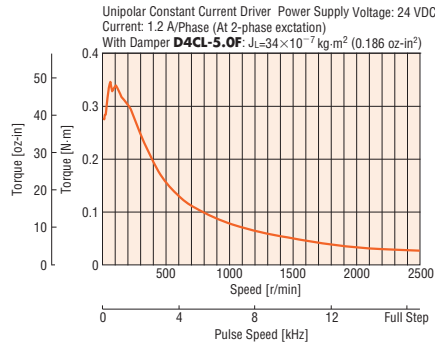

Note

- Depending on the driving conditions, a considerable amount of heat may be generated by the motor. Be sure to keep the motor case temperature at 85°C (185°F) max. in order to protect the encoder.

Dimensions Unit = mm (in.)

Product Name	Motor Product Name	L	Mass kg (lb.)	CAD
PKP243MU09A-R2F □-L	PKP243MU09A-R2F□	46.5 (1.83)	0.26 (0.57)	B1104
PKP244MU12A-R2F □-L	PKP244MU12A-R2F□	52.5 (2.07)	0.31 (0.68)	B1105

- Applicable Connector (Molex)

	Motor	Encoder
Connector Housing	51103-0600	51021-0800
Contact	50351-8100	50079-8100
Crimp Tool	57295-5000	57067-3000

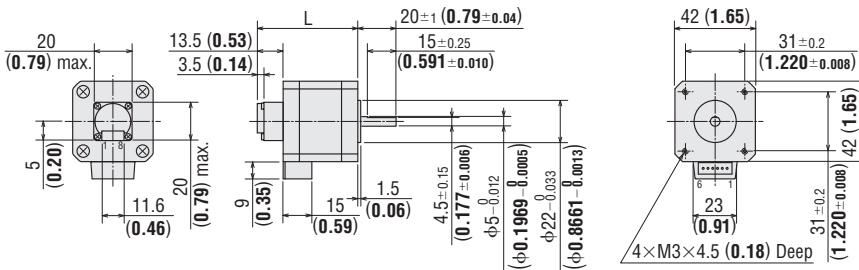

- Included

Motor connection cable
Product Name: **LC2U06B**

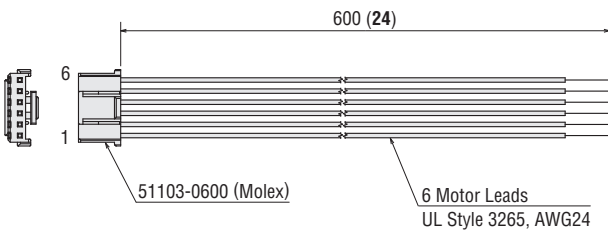

- Included

Encoder connection cable

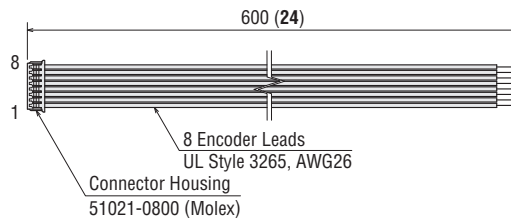

Step Angle 0.9° Frame size 56.4 mm (2.22 in.) Unipolar 6 Lead Wires

Specifications

Product Name	Holding Torque N·m (oz·in)	Rated Current A/phase	Voltage VDC	Resistance Ω/phase	Inductance mH/phase	Rotor Inertia J kg·m ² (oz·in ²)	Lead Wires
PKP264MU20A-R2F □-L	0.51 (72)	2	2.9	1.45	2.1	120×10 ⁻⁷ (0.66)	6
PKP266MU20A-R2F □-L	1.1 (155)		4	2	3.9	290×10 ⁻⁷ (1.59)	
PKP268MU20A-R2F □-L	1.75 (247)		4.9	2.45	5.6	490×10 ⁻⁷ (2.7)	

- Enter the encoder type (**L** for Line Driver output, **blank** for Voltage output) in the box (□) within the product name.
- A motor connection cable 0.6 m (2 ft.) and encoder connection cable 0.6 m (2 ft.) are included with each product.

Speed – Torque Characteristics fs: Max. starting frequency

PKP264MU20

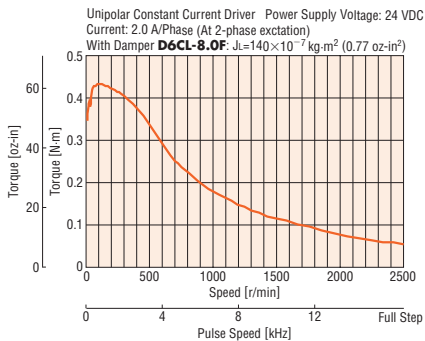

PKP266MU20

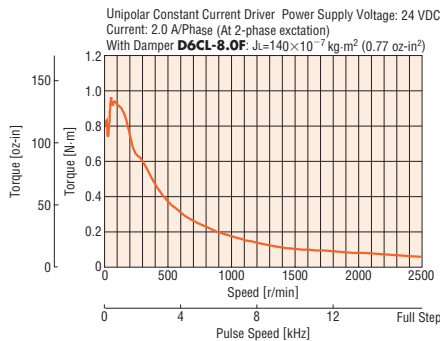

PKP268MU20

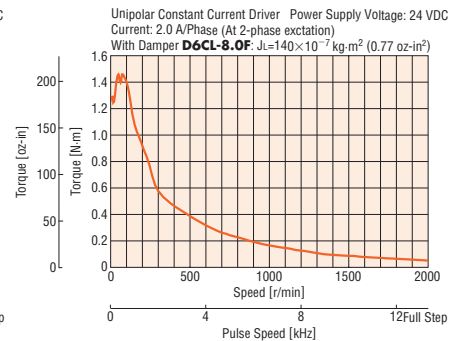

Note

- Depending on the driving conditions, a considerable amount of heat may be generated by the motor. Be sure to keep the motor case temperature at 85°C (185°F) max. in order to protect the encoder.

Dimensions Unit = mm (in.)

Product Name	Motor Product Name	L	Mass kg (lb.)	CAD
PKP264MU20A-R2F □-L	PKP264MU20A-R2F□	55.5 (2.18)	0.47 (1.04)	B1108
PKP266MU20A-R2F □-L	PKP266MU20A-R2F□	70.5 (2.78)	0.74 (1.63)	B1109
PKP268MU20A-R2F □-L	PKP268MU20A-R2F□	92.5 (3.64)	1.11 (2.45)	B1110

- Applicable Connector (Molex)

	Motor	Encoder
Connector Housing	51067-0600	51021-0800
Contact	50217-9101	50079-8100
Crimp Tool	57189-5000 57190-5000	57067-3000

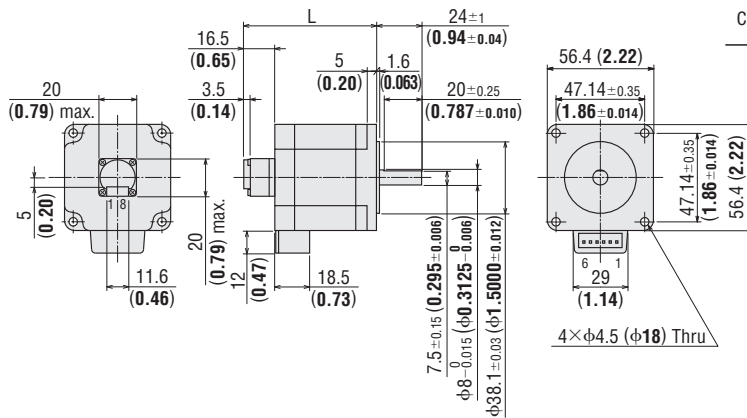

- Included

Motor connection cable
Product Name: **LC2U06C**

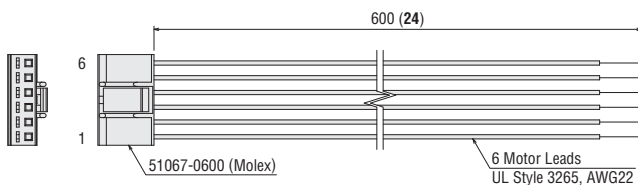

- Included

Encoder connection cable

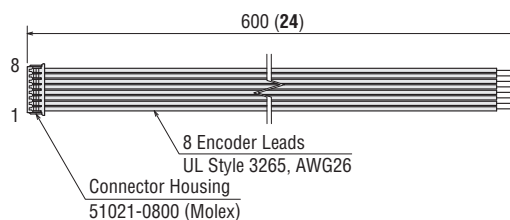

General Specifications

Item	Specification	
Heat-Resistant Class	130 (B)	
Insulation Resistance	100 MΩ or more when 500 VDC megger is applied between the windings and the case under normal ambient temperature and humidity.	
Dielectric Strength	Sufficient to withstand 1.0 kVAC at 60Hz applied between the windings and the case for 1 minute, under normal ambient temperature and humidity. (0.5 kV for models with a frame size of 42 mm (1.65 in.))	
Operating Environment (In operation)	Ambient Temperature	-10~+50°C (+14~+122°F) (non-freezing)
	Ambient Humidity	85% max. (non-condensing)
	Atmosphere	No corrosive gases or dust. The product should not be exposed to water, oil or other liquids.
Temperature Rise	<ul style="list-style-type: none"> PKP21□, PKP243, PKP245: Temperature rise of the windings is 80°C (176°F) or less (measured by the resistance change method) at the rated voltage, at standstill, and 2-phases excited. PK29□, PKP22□, PKP23□, PKP244, PKP246, PKP26□: Temperature rise of the windings is 80°C (176°F) or less (measured by the resistance change method) at the rated current, at standstill, and 2-phases excited. <p>The following motors are measured with a radiation plate (material aluminum). PKP22□ and PKP23□: 115×115×5 mm (4.53×4.53×0.20 in.) PKP244 and PKP246: 175×175×5 mm (6.89×6.89×0.20 in.) PKP26□: 250×250×10 mm (9.84×9.84×0.39 in.)</p>	
Stop Position Accuracy*1	±3 arcmin (±0.05°) [PKP21□: ±5 arcmin (±0.083°)]	
Shaft Runout	0.05 mm (0.002 in.) T.I.R.*4	
Radial Play*2	0.025 mm (0.001 in.) maximum (load 5 N (1.12 lb.))	
Axial Play*3	0.075 mm (0.003 in.) maximum (load 10 N (2.2 lb.)) [The load for PKP21□ is 1 N (0.225 lb.)]	
Concentricity of Installing Pilot to the Shaft	0.075 mm (0.003 in.) T.I.R.*4	
Perpendicularity of Installation Surface to the Shaft	0.075 mm (0.003 in.) T.I.R.*4	

*1 This value is for full step under no load. (The value changes with the size of the load.)

*2 Radial Play: Displacement in shaft position in the radial direction when a 5 N (1.12 lb.) load is applied in the vertical direction to the tip of the motor shaft.

*3 Axial Play: Displacement in shaft position in the axial direction when a 10 N (2.2 lb.) [PKP21□ is 1 N (0.225 lb.)] load is applied to the motor shaft in the axial direction.

*4 T. I. R. (Total Indicator Reading): The total dial gauge reading when the measurement section is rotated one revolution centered on the reference axis center.

Note

- Do not measure insulation resistance or perform the dielectric strength test while the motor and driver are connected. Also, do not conduct these tests on the motor encoder section.
- For Radial load and Permissible Axial load, see 2015-2016 General Catalog, page A-262.

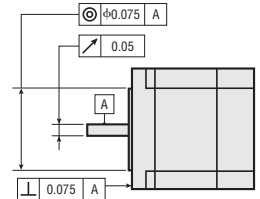

Encoder Specifications

Encoder Product Name	R2EL	R2FL
Resolution	200 P/R	400 P/R
Output Circuit Type	Line Driver	
Output Mode	Incremental	
Output Signal	A-phase, B-phase, Z-phase (3ch)	
Power Supply Voltage	5 VDC ±10%	
Current	30 mA max.	

- A voltage output type encoder output circuit is also available. For details, please contact the nearest Oriental Motor sales office.

Inner Wiring Diagram for Motor

Unipolar 6 Lead Wires

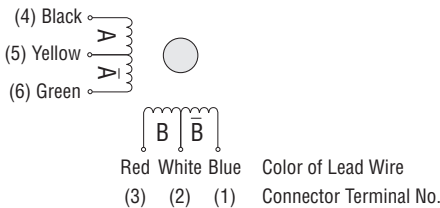

Unipolar 5 Lead Wires

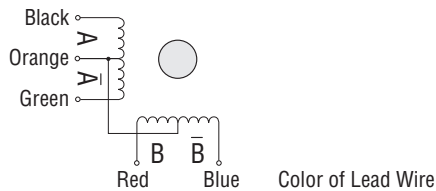

Specifications are subject to change without notice. This catalog was published in August, 2015.

ORIENTAL MOTOR U.S.A. CORP.

Western Sales and Customer Service Center

Tel: (310) 715-3301 Fax: (310) 225-2594

Los Angeles

Tel: (310) 715-3301

San Jose

Tel: (408) 392-9735

Seattle

Tel: (425) 214-7559

Technical Support

Tel: (800) 468-3982 / 8:30 A.M. to 5:00 P.M., P.S.T. (M-F)
7:30 A.M. to 5:00 P.M., C.S.T. (M-F)

E-mail: techsupport@orientalmotor.com

Midwest Sales and Customer Service Center

Tel: (847) 871-5900 Fax: (847) 472-2623

Chicago

Tel: (847) 871-5900

Dallas

Tel: (214) 432-3386

Toronto

Tel: (905) 502-5333

Eastern Sales and Customer Service Center

Tel: (781) 848-2426 Fax: (781) 848-2617

Boston

Tel: (781) 848-2426

Charlotte

Tel: (704) 766-1335

New York

Tel: (973) 359-1100

**Obtain Specifications, Online Training
and Purchase Products at:
www.orientalmotor.com**