

# Low-Speed Synchronous Motors SMK Series

Introduction	Motor & Driver Packages										2-Phase Stepping Motors without Encoder	2-Phase Stepping Motors with Encoder	Driver with Indexer	Controllers			Low-Speed Synchronous Motors	Accessories	Before Using a Stepping Motor
	AS	AS PLUS	ASC	RK	CRK II	CSK	PMC	UMK	CSK	PK/PV				PK	UI2120G	EMP401			
	Closed Loop <i>Q57ZP</i>	DC Input	DC Input	5-Phase Microstep AC Input	DC Input	5-Phase Full/Half DC Input	2-Phase Full/Half AC Input	DC Input	DC Input	DC Input	DC Input	DC Input	DC Input	DC Input	DC Input	DC Input	DC Input	DC Input	

Additional Information	
Technical Reference .....	F-1
General Information .....	G-1

## Low-Speed Synchronous Motors

# SMK Series

Low-speed synchronous motors provide highly precise speed regulation, low-speed rotation, and quick bi-directional rotation. The basic construction of low-speed synchronous motors is the same as that of stepping motors. Since they can be driven by an AC power supply, they are sometimes called AC stepping motors.

### Features

#### Low-Speed-Synchronous Rotation

The motor rotates at a speed proportional to and accurately synchronized with the frequency of the power supply. A fluctuation in load does not affect the rotation speed.

At 50 Hz 60 r/min (\* 30 r/min)

At 60 Hz 72 r/min (\* 36 r/min)

\* For **SMK014MA-□**

#### Continuous Rated Capacitor-Run Motor

This motor can be driven at a continuous rating even when bi-directional operation is required.

#### Superb Starting, Stopping and Reversing Characteristics

If operated within the permissible load inertia, the motor can start, stop and reverse within 1.5 cycles (0.03 sec at 50 Hz, 0.025 sec at 60 Hz) of the power supply frequency.

● Suitable for equipment that starts and stops repeatedly such as conveyors.

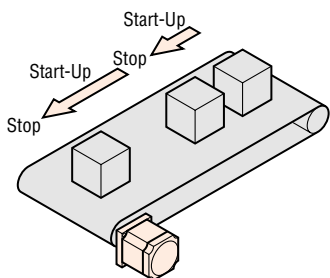

● Bi-directional operation can be repeated continuously.

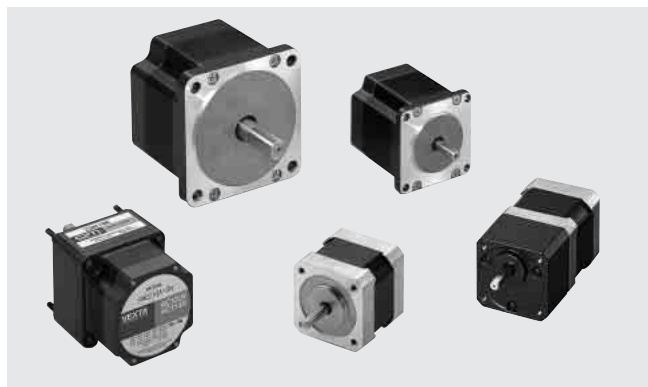
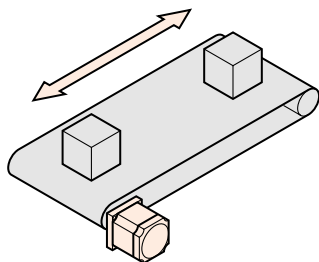

#### Precise Positioning

The motor can be stopped instantly by turning off the power supply. The stopping accuracy within the motor's permissible load inertia is  $\pm 10^\circ$ . When a precision switch is used, simple and precise positioning is possible.

#### Lowering Applications

Constant speed can be maintained even during lowering operations. Low-speed synchronous motors are suitable for applications, where vertical operation at a constant speed is required.

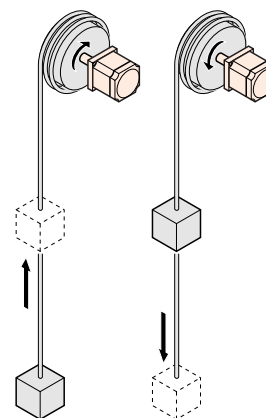

#### Holding Torque

Since a permanent-magnet, multi-poled rotor is used, the motor has holding torque even when the motor is not energized. When used with a gearhead, comparatively high holding torque can be utilized.

● When a larger holding torque is required, a DC power supply can be connected as soon as the AC power supply is cut off.

DC Excitation → Page C-281

#### Low-Noise Gearheads

Pinion shaft models are available that can be connected directly to standard Oriental Motor **GN**-type low-noise gearheads.

## Safety Standards and CE Marking

Model	Standards	Certification Body	Standards File No.	CE Marking
Motor	UL1004 UL519 CSA C22.2 No.100 CSA C22.2 No.77	UL	E64199	Low Voltage Directives

(**SMK014**, **SMK0A** are not recognized.)  
Details of Safety Standards → Page G-2

## System Configuration

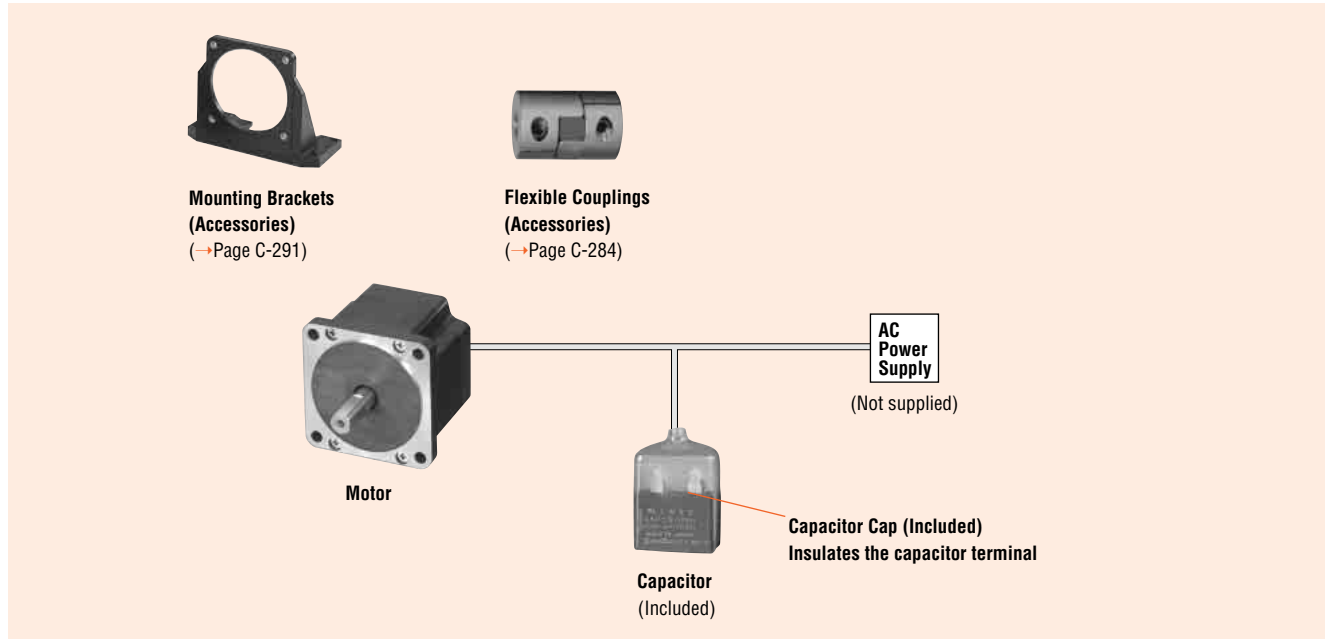

## Product Number Code

### Motor

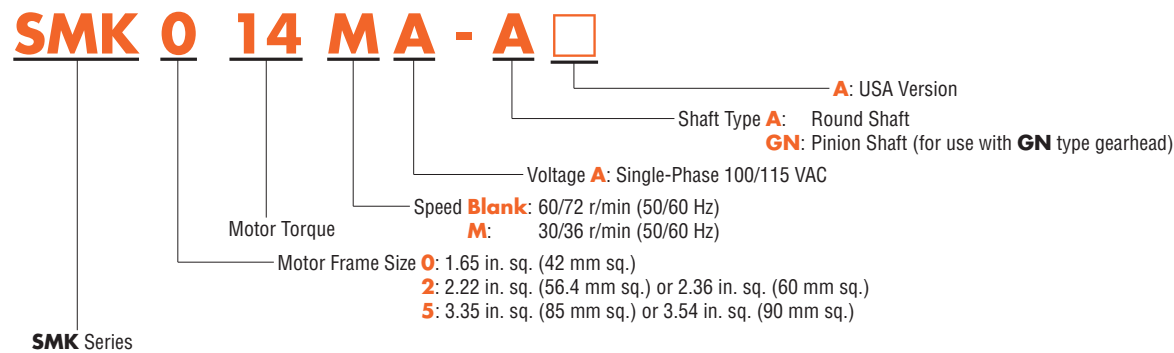

### Gearhead

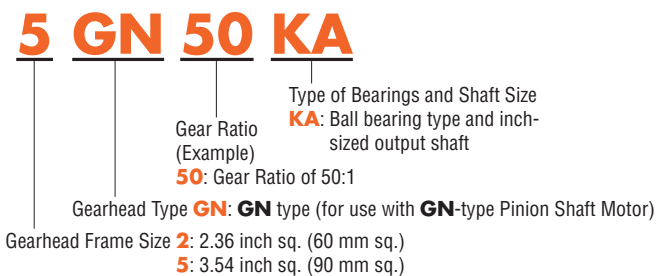

### Geared Motor

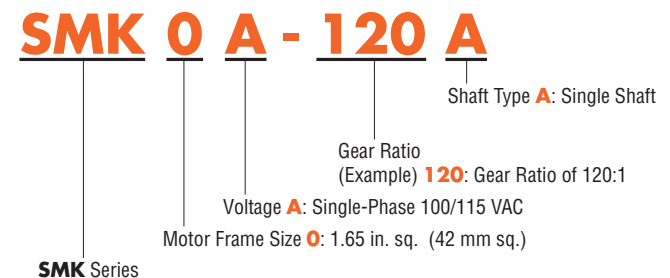

Introduction

AS

AS PLUS

ASC

RK

CRK II

CSK

PMC

UMK

CSK

PK/PV

PK

UI2120G

EMP401

EMP402

SG8030J

Low Speed Synchronous Motors

Accessories

Before Using a Stepping Motor

Controllers

Driver with Inducer

Encoder

Encoder

Encoder

Encoder

Encoder

Encoder

Encoder

Encoder

Encoder

Encoder

## Product Line

### Motor

Model
<b>SMK014A-A</b>
<b>SMK014MA-A</b>
<b>SMK237A-A</b>
<b>SMK5100A-AA</b>
<b>SMK5160A-AA</b>
<b>SMK216A-GN</b> (GN-type Pinion Shaft)
<b>SMK550A-GN</b> (GN-type Pinion Shaft)

### Geared Motor

Model	Gear Ratio
<b>SMK0A-□A</b>	<b>3~120</b>

- Enter the gear ratio in the box (□) within the model number.

### Gearheads (Sold Separately)

Model	Gear Ratio
<b>2GN□KA</b>	<b>3~180</b>
<b>5GN□KA</b>	<b>3~180</b>

- Enter the gear ratio in the box (□) within the model number.

## Specifications — Continuous Rating

### Motor

 (Except for **SMK014**)

Model	Voltage VAC	Frequency Hz	Current A	Torque		Speed r/min	Holding Torque		Rotor Inertia J oz-in <sup>2</sup> kg-m <sup>2</sup>	Capacitor μF	External Resistor	
				oz-in	N-m		oz-in	mN-m			Ω	W
<b>SMK014A-A</b>	Single-Phase 100	50	0.043	15.6 (0.11)	60	1.27 (9)	0.3 (55×10 <sup>-7</sup> )	0.6	—	—		
		60	0.046	17.0 (0.12)	72							
<b>SMK014MA-A</b>	Single-Phase 100	50	0.043	15.6 (0.11)	30	0.63 (4.5)	0.3 (55×10 <sup>-7</sup> )	0.6	—	—		
		60	0.046	17.0 (0.12)	36							
<b>SMK237A-A</b>	Single-Phase 100	50	0.08	52 (0.37)	60	3.5 (25)	1.64 (300×10 <sup>-7</sup> )	1.2	—	—		
		60	0.09	52 (0.37)	72							
<b>SMK216A-GN</b>	Single-Phase 100	50	0.08	22 (0.16)	60	2.1 (15)*2	0.66 (120×10 <sup>-7</sup> )	1.2	—	—		
		60	0.09	22 (0.16)	72							
<b>SMK5100A-AA</b>	Single-Phase 100	50	0.17	142 (1.0)	60	5.1 (36)	7.7 (1400×10 <sup>-7</sup> )	2.5	400	30		
		60	0.20	142 (1.0)	72							
<b>SMK5160A-AA</b>	Single-Phase 100	50	0.23	220 (1.6)	60	12.6 (89)	14.8 (2700×10 <sup>-7</sup> )	2.5	400	30		
		60	0.26	250 (1.8)	72							
<b>SMK550A-GN</b>	Single-Phase 100	50	0.06	71 (0.5)	60	5.1 (36)*2	7.7 (1400×10 <sup>-7</sup> )	0.6	400	30		
		60	0.07	71 (0.5)	72							
<b>SMK550A-GN</b>	Single-Phase 115	50	0.07	71 (0.5)	60	5.1 (36)*2	7.7 (1400×10 <sup>-7</sup> )	0.6	400	30		
		60	0.07	71 (0.5)	72							

### Geared Motor

Model	Voltage VAC	Frequency Hz	Current A	Speed*1 r/min	Holding Torque*2		Rotor Inertia J		Capacitor μF
					oz-in	mN-m	oz-in <sup>2</sup>	kg-m <sup>2</sup>	
<b>SMK0A-□A</b>	Single-Phase 100	50	0.043	60	1.27 (9)	0.3 (55×10 <sup>-7</sup> )	0.6		
		60	0.046	72					
		60	0.053	72					
<b>SMK0A-□A</b>	Single-Phase 115	50	0.043	60	1.27 (9)	0.3 (55×10 <sup>-7</sup> )	0.6		
		60	0.046	72					
		60	0.053	72					

\*1 50 Hz: Gear output shaft speed = 60/Gear Ratio [r/min]

60 Hz: Gear output shaft speed = 72/Gear Ratio [r/min]

\*2 This value applies to round shaft motors. To calculate holding torque for gearmotors, use the following formula: listed holding torque × gear ratio.

Note that the gearmotor holding torque should be lower than the permissible torque on the gear output shaft. **Permissible Torque with Gearhead Attached** → Page C-272

## General Specifications

Item	Specifications
Shaft Runout	0.002 inch (0.05 mm) T.I.R.*1
Concentricity	0.003 inch (0.075 mm) T.I.R.*1
Perpendicularity	0.003 inch (0.075 mm) T.I.R.*1
Shaft Radial Play*2	0.001 inch (0.025 mm) maximum [Load 1.12 lb. (5 N)]
Shaft Axial Play*3	0.003 inch (0.075 mm) maximum [Load 2.2 lb. (10 N)]
Step Accuracy	±3.6°
Insulation Resistance	100 MΩ or more when the megger reading between the windings and the case is 500 VDC.
Dielectric Strength	Sufficient to withstand 1.5 kV at 60 Hz applied between the windings and the case for one minute.
Insulation Class	Class E [248°F (120°C)] *Recognized as Class A [221°F (105°C)] by UL and CSA standard
Temperature Rise	99°F (55°C) or less as measured by thermometer method after rated operation.
Ambient Temperature Range	14°F~104°F (-10°C~+40°C) (nonfreezing)

\*1 T.I.R. (Total Indicator Reading): Total dial gauge reading when the measurement section is rotated 1 revolution, centered on the reference axis center.

\*2 Radial Play: Displacement in shaft position in the radial direction when a 1.12 lb. (5 N) load is applied to the motor shaft tip in a radial direction.

\*3 Axial Play: Displacement in shaft position in the axial direction when a 2.2 lb. (10 N) load is applied to the motor shaft in the axial direction.

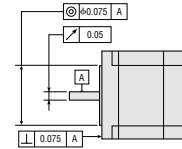

## Permissible Torque with Gearhead Attached

Unit = Upper values: lb-in/Lower values: N-m

Motor/Gearhead	Gear Ratio																			
	3	3.6	5	6	7.5	9	12.5	15	18	25	30	36	50	60	75	90	100	120	150	180
<b>SMK216A-GN/2GN</b> □KA *1	3.5	4.4	6.1	7	8.8	10.6	13.2	15.9	16.8	18.5	21	24	26	26	26	26	26	26	26	26
	0.4	0.5	0.7	0.8	1	1.2	1.5	1.8	1.9	2.1	2.4	2.8	3	3	3	3	3	3	3	3
<b>SMK550A-GN/5GN</b> □KA *1	12.3	15	20	24	30	38	39	44	53	66	79	79	88	88	88	88	88	88	88	88
	1.4	1.7	2.3	2.8	3.5	4.3	4.5	5	6	7.5	9	9	10	10	10	10	10	10	10	10
<b>SMK0A</b> -□A	1.32	1.59	—	—	3	3	—	3	3	—	3	3.2	3.6	4.1	—	—	4.1	4.9	—	—
	0.15	0.18	—	—	0.35	0.35	—	0.35	0.35	—	0.35	0.37	0.41	0.47	—	—	0.47	0.56	—	—

\*1 Gearheads are sold separately.

• The box (□) represents the desired gear ratio, which becomes part of the product number for the gearhead or gearmotor.

• A white background indicates that the output shaft of the gearhead rotates in the same direction as the output shaft of the motor. A colored background indicates rotation in the opposite direction.

## Permissible Overhung Load and Permissible Thrust Load

### Motor, Geared Motor

Unit = Upper values: lb./Lower values: N

Model	Overhung Load Distance from Shaft End [inch (mm)]					Thrust Load	
	0	0.2 (5)	0.39 (10)	0.59 (15)	0.79 (20)		
<b>SMK014</b>	4.5	5.6	7.6	11.7	—	The permissible thrust load shall be no greater than the motor mass.	
	20	25	34	52	—		
<b>SMK237</b>	12.1	15	20	29	—		
	54	67	89	130	—		
<b>SMK5100, SMK5160</b>	58	65	76	87	108		
	260	290	340	390	480		
<b>SMK0A</b> -□	2.2	3.3	4.5	6.7	—		3.3
	10	15	20	30	—		15

### Gearhead

Unit = Upper values: lb./Lower values: N

Model	Gear Ratio	Overhung Load Distance from Shaft End [inch (mm)]		Thrust Load
		0.39 (10)	0.79 (20)	
<b>2GN</b> □KA	<b>3~18</b>	11.2	18	6.7
		50	80	
	<b>25~180</b>	27	40	
120		180	—	
<b>5GN</b> □KA	<b>3~18</b>	56	78	22
		250	350	
	<b>25~180</b>	67	101	
300		450	—	

## Permissible Load Inertia

Starting, stopping and reversing characteristics vary according to the amount of load inertia directly coupled to the motor. Permissible load inertia, therefore, refers to the upper limit of load inertia under which the motor can be operated normally when the load is connected directly to the motor shaft. When the amount of load inertia is too great, the motor may vibrate or reverse direction. It is recommended to use flexible couplings when connecting the load to the motor shaft.

### Permissible Load Inertia for Geared Motors (J)

#### Motor/Gearhead

Unit = Upper values: lb-in<sup>2</sup>/Lower values: ×10<sup>-4</sup>kg-m<sup>2</sup>

Motor/Gearhead	Gear Ratio																			
	3	3.6	5	6	7.5	9	12.5	15	18	25	30	36	50	60	75	90	100	120	150	180
SMK216A-GN/2GN□KA	1.85	2.6	5.1	7.4	11.5	16.6	32	46	53	53	53	53	53	53	53	53	53	53	53	53
	5.4	7.7	15	21.6	33.7	48.6	93.7	135	155	155	155	155	155	155	155	155	155	155	155	155
SMK550A-GN/5GN□KA	22	31	60	86	135	194	370	540	640	640	640	640	640	640	640	640	640	640	640	640
	63	90.7	175	252	393.7	567	1093	1575	1875	1875	1875	1875	1875	1875	1875	1875	1875	1875	1875	1875

#### Geared Motor

Unit = Upper values: lb-in<sup>2</sup>/Lower values: ×10<sup>-4</sup>kg-m<sup>2</sup>

Gearmotor	Gear Ratio											
	3	3.6	7.5	9	15	18	30	36	50	60	100	120
SMK0A-□A	0.82	1.2	5.1	7.5	13.7	13.7	13.7	13.7	13.7	13.7	13.7	13.7
	2.4	3.5	15	22	40	40	40	40	40	40	40	40

## Dimensions Scale 1/4, Unit = inch (mm)

### Motor

#### SMK014A-A, SMK014MA-A

Weight: 0.66 lb. (0.3 kg)

DXF B301

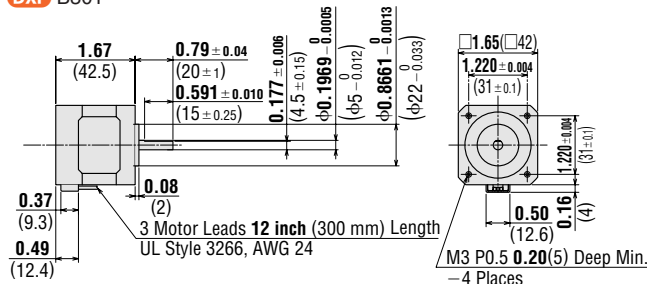

### Motor

#### SMK237A-A

Weight: 1.5 lb. (0.7 kg)

DXF B126

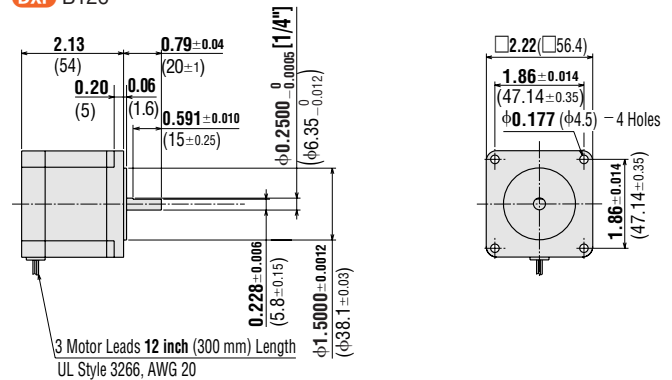

### Motor

#### SMK5100A-AA

Weight: 3.7 lb. (1.7 kg)

DXF B127U

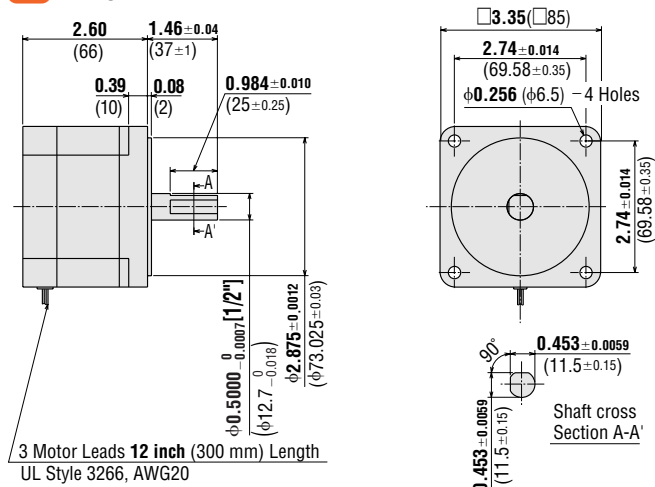

### Motor

#### SMK5160A-AA

Weight: 6.2 lb. (2.8 kg)

DXF B128U

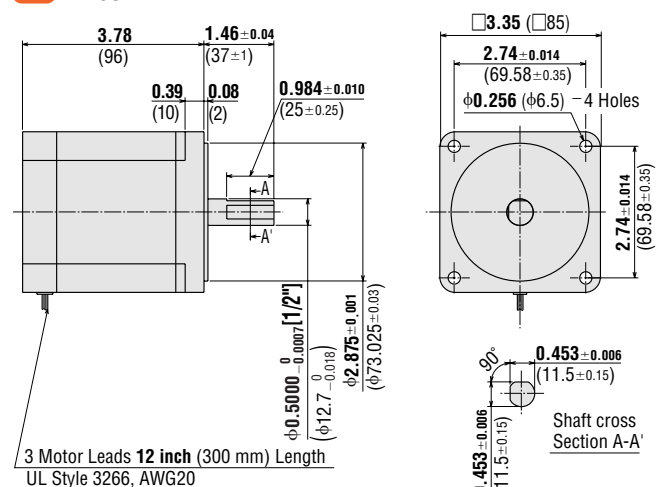

**● Motor/Gearhead**  
**SMK216A-GN/2GN□KA**

Weight: 1.9 lb. (0.85 kg)  
**DXF** B129AU (2GN3K~18KA)  
 B129BU (2GN25K~180KA)

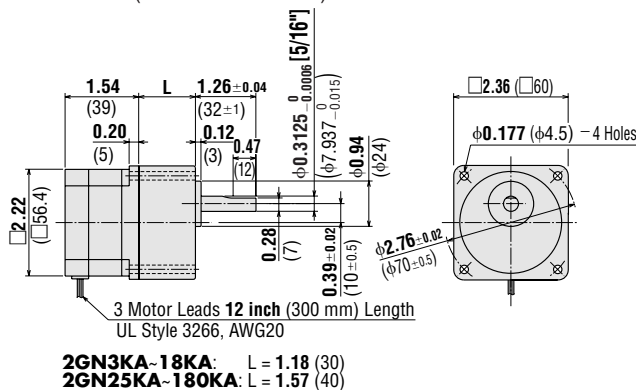

**● Motor/Gearhead**  
**SMK550A-GN/5GN□KA**

Weight: 7.0 lb. (3.2 kg)  
**DXF** B130AU (5GN3KA~18KA)  
 B130BU (5GN25KA~180KA)

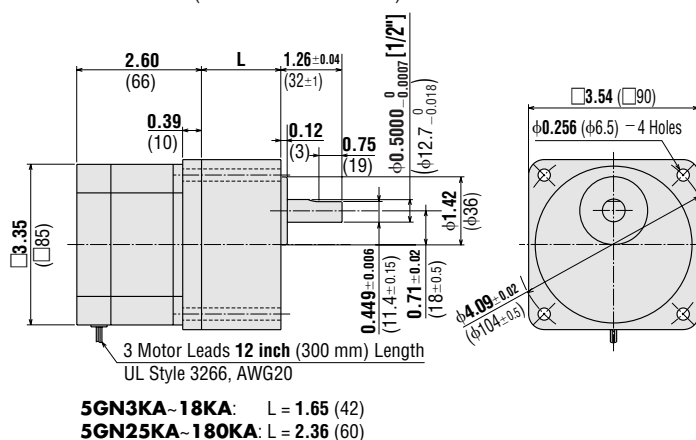

**● Geared Motor**  
**SMK0A-□A**

Weight: 1.1 lb. (0.5 kg)  
**DXF** B323

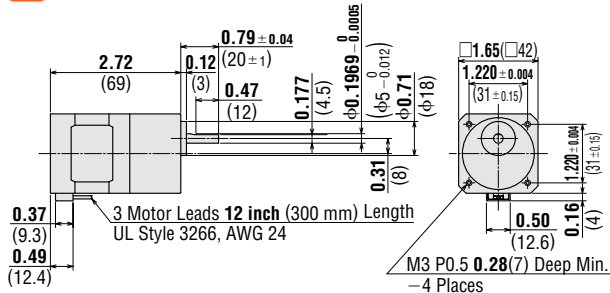

**● Capacitor** (included with the motor) Unit = inch (mm)

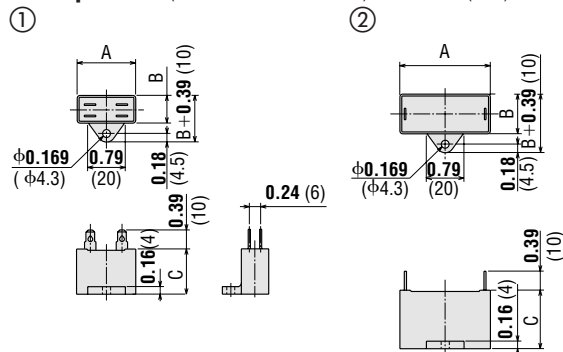

**● External Resistor** (included with **SMK5□** only)

Weight: 2.1 oz. (60 g)

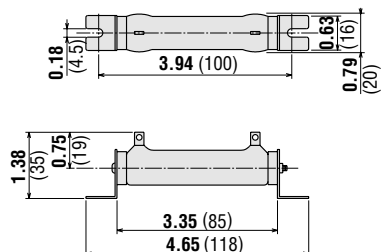

Motor Model	Capacitor Model	Dimensions inch (mm)			Weight oz. (g)	No.
		A	B	C		
<b>SMK014A-A</b> <b>SMK014MA-A</b>	CH06BFAUL	1.22 (31)	0.57 (14.5)	0.93 (23.5)	0.53 (15)	①
<b>SMK0A-□A</b> <b>SMK216A-GN</b> <b>SMK237A-A</b>	CH12UL	1.22 (31)	0.57 (14.5)	0.93 (23.5)	0.6 (17)	②
<b>SMK550A-GN</b>	CH06BUL	1.22 (31)	0.57 (14.5)	0.93 (23.5)	0.53 (15)	②
<b>SMK5100A-AA</b> <b>SMK5160A-AA</b>	CH25UL	1.22 (31)	0.67 (17)	1.07 (27)	0.71 (20)	②

● Capacitor cap is included with the capacitor.

Introduction	AS	AS PLUS	ASC	RK	CRK II	CSK	PMC	UMK	CSK	PK/PV	PK	UI2120G	EMP401	EMP402	SG8030J	Accessories	SMK	



## Connection and Operation

When the switch is set to “CW”, the motor rotates in the clockwise direction. When set to “CCW”, the motor rotates in the counterclockwise direction. The motor can be stopped instantly by turning off the power supply. The direction of motor rotation is as viewed from the shaft end of the motor. The capacitor and external resistor (for **SMK5**□ only) are included with the motor.

### SMK0 Type

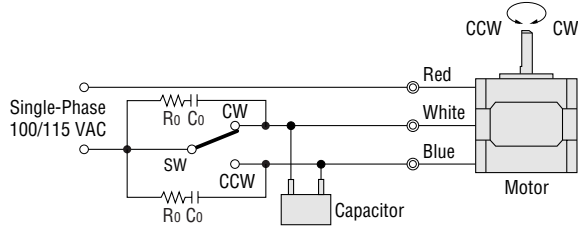

### SMK2 Type

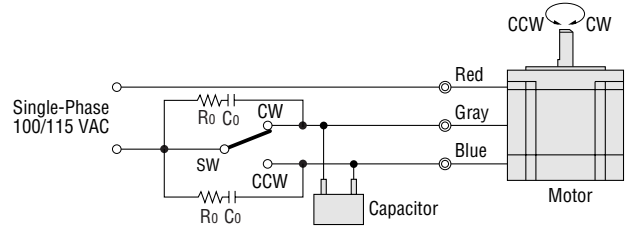

### SMK5 Type

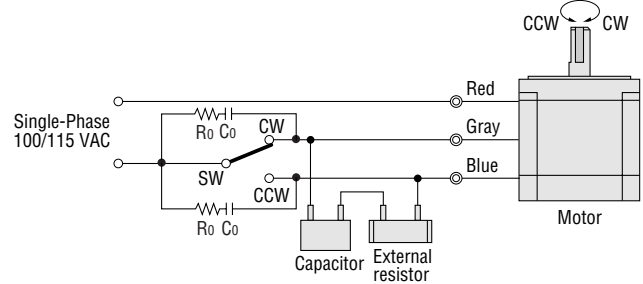

- To protect the contact point of relays and switches, always connect the accessory surge suppressor. CR circuit for surge suppression is available as an accessory. →Page A-218
- When the gearedmotor or **GN** gearheads are used, the rotating direction of output shaft differs according to the gear ratio.

### Starting Time

Low-speed synchronous motors offer superb starting, stopping and reversing characteristics. Provided that the motor is operating within permissible load inertia limits, it can be started, stopped or reversed within 1.5 cycles of the applied frequency. The motor will start and reach a steady speed in the time shown in the table. As seen in this table, there is a certain amount of variation in the time required for the motor to reach the set speed. This is attributable to factors linked with the phase of the power source and the relative positions of the rotor and stator when the current is applied. One method of reducing these variations is to use a zero cross switch. Other possibilities include the use of special control circuits.

Model	Load Inertia: J		Starting Time (ms)		Stopping Time (ms)	
	oz-in <sup>2</sup>	kg-m <sup>2</sup>	Start Up	Settling	Settle Down	Settling
<b>SMK014A-A</b>	0	0	2~15	19~37	3~5	7~23
<b>SMK014MA-A</b>	0.75	137×10 <sup>-7</sup>	3~16	25~38	4~7	11~27
<b>SMK0A-□A</b>	1.50	275×10 <sup>-7</sup>	6~22	14~48	5~9	23~32
<b>SMK237A-A</b>	0	0	2~15	19~37	3~5	7~23
	6.8	1250×10 <sup>-7</sup>	3~16	25~38	4~7	11~27
	13.7	2500×10 <sup>-7</sup>	6~22	14~48	5~9	23~32
<b>SMK216A-GN</b>	0	0	2~15	19~37	3~5	7~23
	1.64	300×10 <sup>-7</sup>	3~16	25~38	4~7	11~27
	3.3	600×10 <sup>-7</sup>	6~22	14~48	5~9	23~32
<b>SMK5100A-AA</b> <b>SMK550A-GN</b>	0	0	2~15	19~37	3~5	7~23
	19.1	3500×10 <sup>-7</sup>	3~16	25~38	4~7	11~27
	38	7000×10 <sup>-7</sup>	6~22	14~48	5~9	23~32
<b>SMK5160A-AA</b>	0	0	2~15	19~37	3~5	7~23
	33	6000×10 <sup>-7</sup>	3~16	25~38	4~7	11~27
	66	12000×10 <sup>-7</sup>	6~22	14~48	5~9	23~32

- Enter the gear ratio in the box (□) within the model number.



## DC Excitation

When a holding torque larger than the static holding torque of the stopped motor is required, apply a DC voltage after the AC power supply is turned off.

### Connection Diagrams

#### 1-Phase Excitation

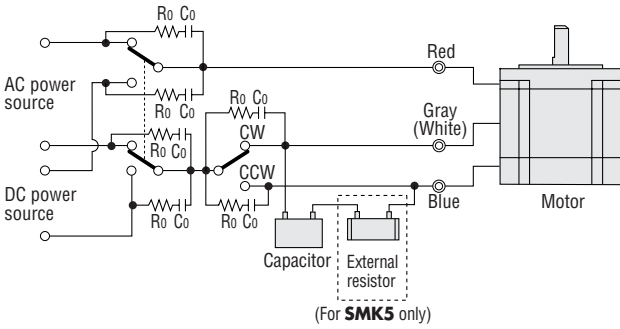

#### 2-Phase Excitation (Series)

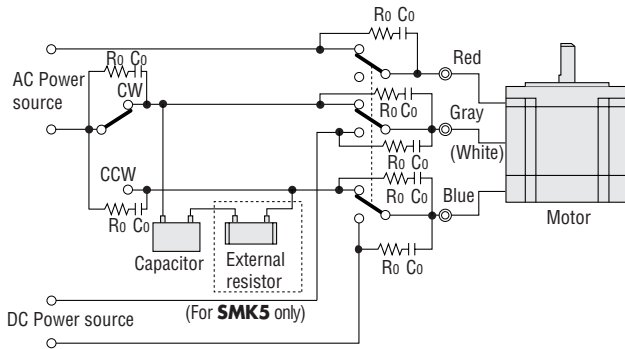

#### 2-Phase Excitation (Parallel)

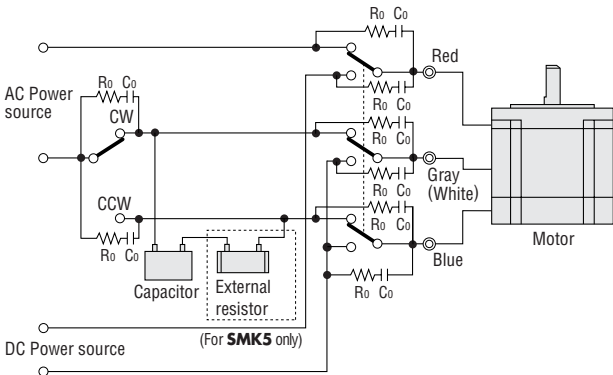

- The white leads listed in parentheses are only for the **SMKO**.
- Connect the supplied external resistor to the capacitor in series for the **SMK5** model.
- External resistors are not needed for the **SMKO** and **SMK2** models.
- To prevent DC power supply damage caused by voltage surges, connect a surge suppressor circuit between the contact points of the relay switches. The **EPCR1201-2** surge suppressor circuit is available as an accessory. → Page A-218

## Characteristics for DC Excitation

**SMK014A-A, SMK014MA-A, SMK0A-□A\***

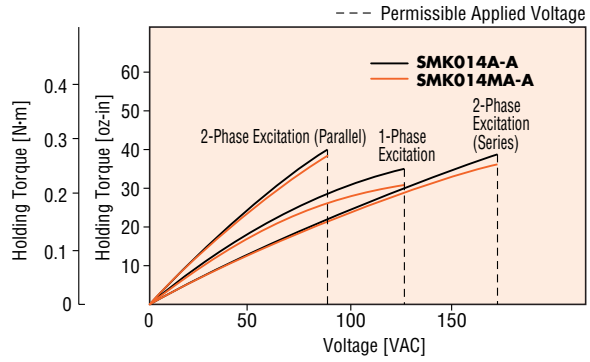

**SMK237A-A, SMK216A-GN\***

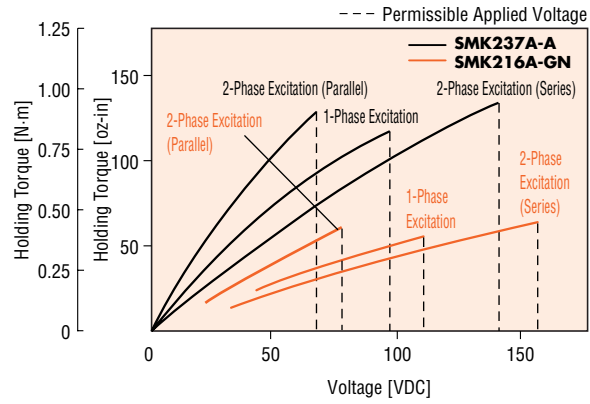

**SMK5100A-AA, SMK550A-GN\***

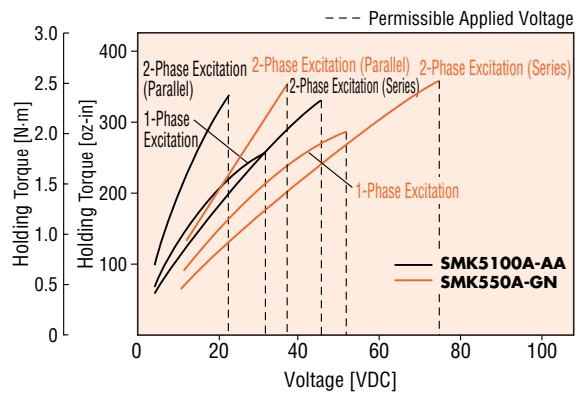

**SMK5160A-AA**

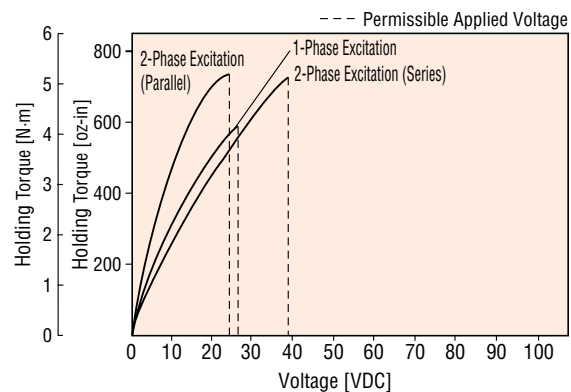

\* These values apply to round shaft motors. To calculate holding torque for gearmotors, use the following formula: listed holding torque × gear ratio. Note that the gearmotor holding torque should be lower than the permissible torque on the gear output shaft. **Permissible Torque with Gearhead Attached** → Page C-277

