

Standard AC Motors

LS Linear Heads

Introduction

Induction Motors

Reversible Motors

Electro-magnetic Brake Motors

V Series

Clutch & Brake Motors

Synchronous Motors

Low-Speed Synchronous Motors

Waterlight, Dust-Resistant Motors

Torque Motors

Right-Angle Gearheads

Linear Heads

Brake Pack

Accessories

Installation

LS Linear Heads

RoHS RoHS-Compliant

LS Linear Heads

● Additional Information ●
Technical reference → Page F-1



Vertical Stroke: **F** Type

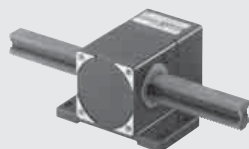

Horizontal Stroke: **B** Type

2LS Type



Vertical Stroke: **F** Type

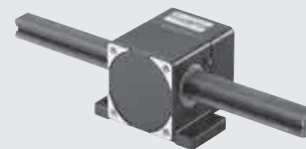

Horizontal Stroke: **B** Type

4LS Type

Overview

● An Easy to Achieve Linear Motion with Standard AC Motors

A "linear head" can generate linear motion simply by combining a standard AC motor.

Linear heads can be combined with a wide range of standard AC motors, and are also available with many different stroke lengths for use in simple operations such as push, pull, lift and lower.

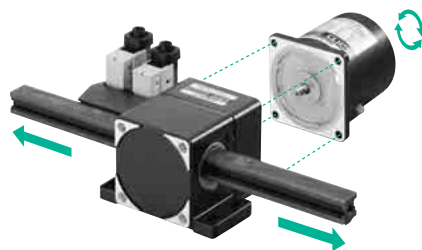

Combined with various motors,
linear motion can be achieved easily.

Features

● High Thrust Force and Large Transportable Mass

The maximum transportable mass is approximately 1.5 times that of a conventional product. (The specific value varies depending on the basic speed of rack.)

- 100 kg (220 lb.) (**4LS** type)
- 30 kg (66 lb.) (**2LS** type)

● Many Stroke Variations

Select the stroke that best suits your specific application.

- 100~1000 mm (3.94~39.37 in.): 10 types (**4LS** type)
- 100~800 mm (3.94~31.50 in.): 8 types (**2LS** type)

● Easy to Achieve Reciprocating Operation

Use the dedicated photomicro sensor (sold separately) and the limit switches (sold separately) to implement reciprocating motion or intermediate stops with ease.

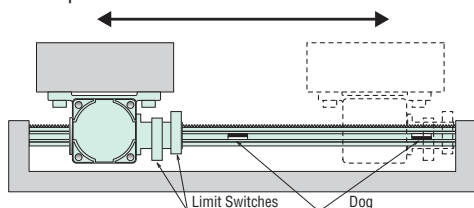

● **RoHS** RoHS-Compliant

The **LS** linear heads conform to the RoHS Directive that prohibits the use of six chemical substances including lead and cadmium.

● Details of RoHS Directive → Page G-38

● Two Installation Directions

Two mounting surfaces are provided. Choose the installation direction that best suits your system.

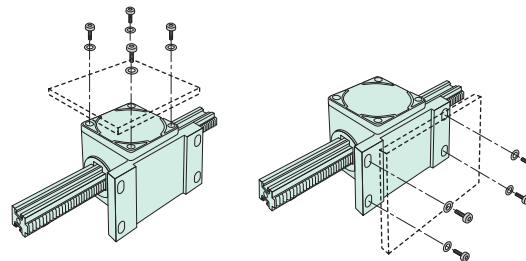

● Flexible Mounting

Each model comes in two types – horizontal type and vertical type – to allow for mounting in different directions to meet various limitations on installation. Choose the type that best suits your system.

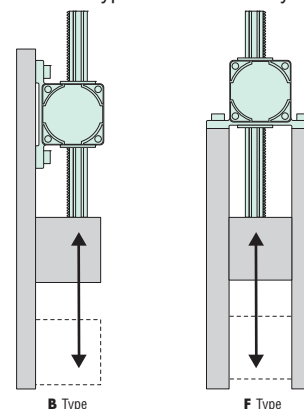

Photomicro Sensor, Limit Switches

● Photomicro Sensor Set (Sold separately) (RoHS)

◇ Model: **PARP-PS2, PARP-PS4**

Specifications and dimensions of photomicro sensor sets → A-303

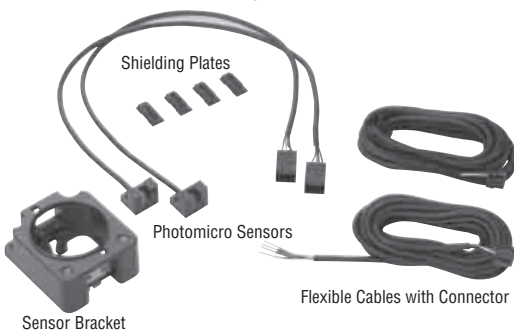

● Installation Example

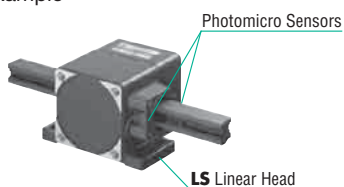

◇ Features of Photomicro Sensor

● Compact Size

The photomicro sensor is compact size which meets space-saving needs. This makes it possible to decrease dead stroke.

● Suitable to Ensure Position Detection Repeatability

Ideally suited for position detection repeatability in the case of detecting the shielding plate from the same direction.

Note:

● Stop position repeatability is affected by overrun of the motor to be combined.

● Two Line Output is Possible

By installing the sensors on both side of the rack, it is possible to detect separately not only signals of both moving ends, but also signals of moving ends and an intermediate stop position.

● Limit Switch Set (Sold separately) (RoHS)

◇ Model: **PARP-MS**

Specifications of limit switch → A-304

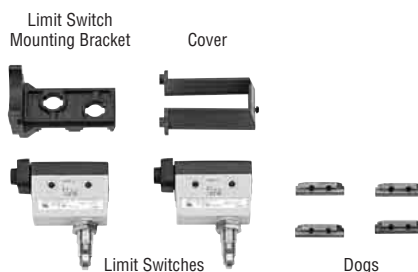

● Installation Example

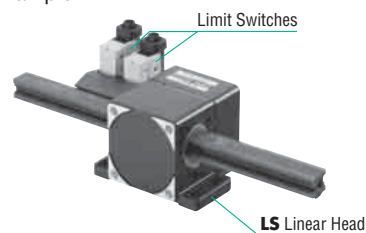

◇ Features of Limit Switches

● Special Dog Shape

The special dog shape allows signals to be output separately at two moving ends, or at a moving end and an intermediate stop position. Accordingly, control can be implemented easily using the minimum number of limit switches.

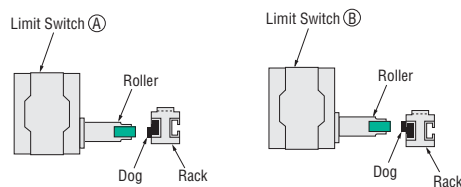

● Easy Position Setting Using Dedicated Limit Switches and Dogs

Since the roller of the limit switch can travel over the dog, multiple-point stop operation can be designed easily by increasing the number of dogs.

The figure below shows an example where the actuator performs reciprocating motion while stopping at two intermediate points. Dog ① defines the home, while dog ② is used for reversing and dogs ③ and ④ cause the actuator to stop at intermediate points. To make control simple, use limit switch ② as signal for home and limit switch ① as signal for intermediate stop or reversing.

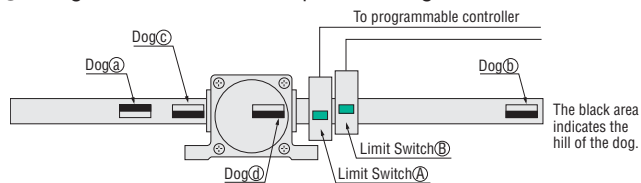

- The dog is 35 mm (1.38 in.) long. The number of dogs that can be installed is limited.
- Relays and a programmable controller will be needed to control the motor using signals detected from these limit switches.

System Configuration

An example of a system configuration with the **LS** linear head and a standard AC motor World **K** Series.

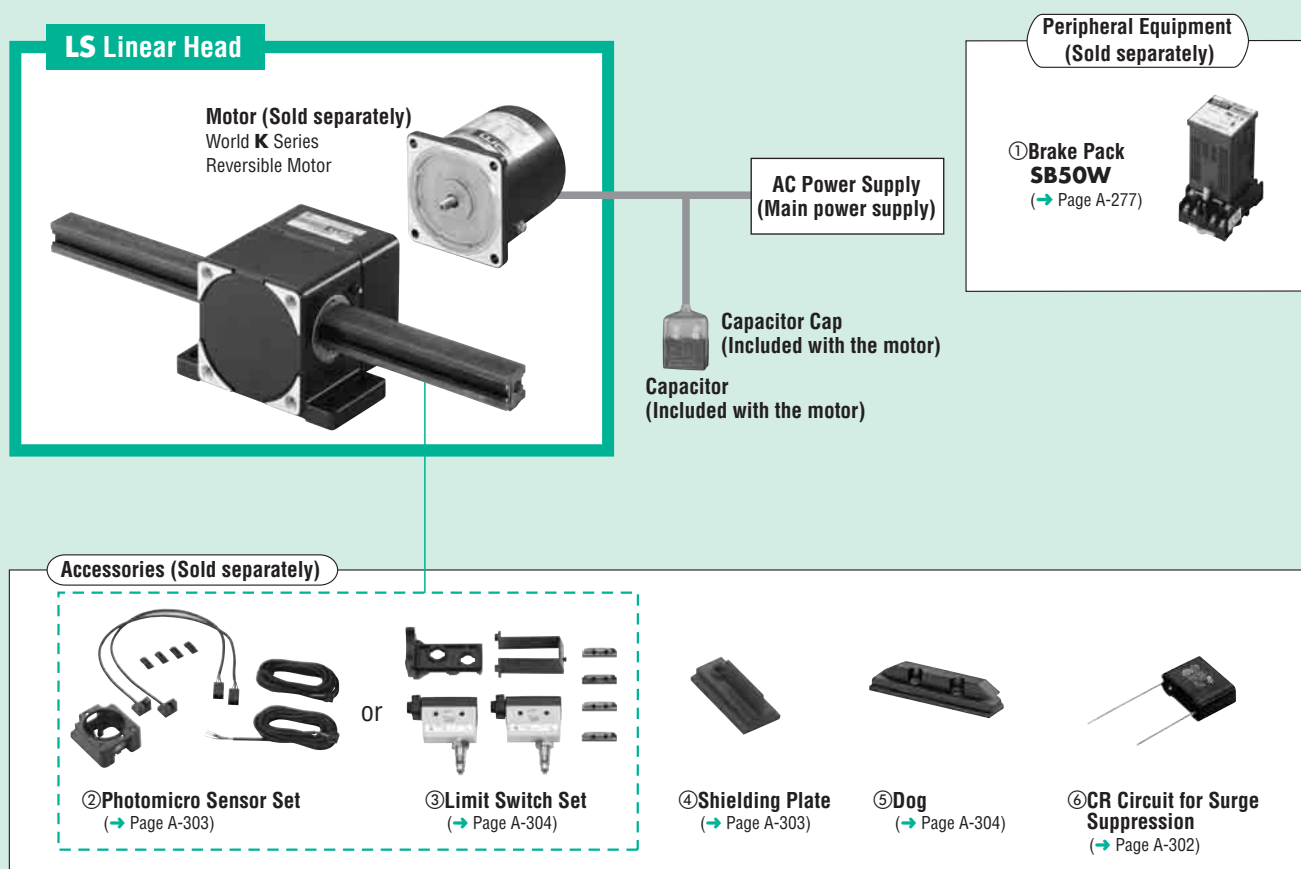

No.	Product Name	Overview	Page
①	Brake Pack	Use this brake pack to stop the motor instantaneously, perform bi-directional operation, and more.	A-277
②	Photomicro Sensor Set	Used for precise home detection, reciprocating motion, return to home and detect the position of the rack.	A-303
③	Limit Switch Set	Used for reciprocating motion, these limit switches can be installed easily to a LS linear head (PARP-MS).	A-304
④	Shielding Plate	Use extra shielding plates if the shielding plates included with the photomicro sensor set are not enough (LXSP-4).	A-303
⑤	Dog	This dog is needed to operate a limit switch during reciprocating motion (LXDT-4).	A-304
⑥	CR Circuit for Surge Suppression	Used to protect relay and switch contacts (EPCR1201-2).	A-302

● Example of System Configuration

(Sold separately)



● The system configuration shown above is an example. Other combinations are available.

Product Number Code

2 LS F 10 - 2

① ② ③ ④ ⑤

①	2: Can be combined with GN pinion motors of frame size 60 mm (2.36 in.)
①	4: Can be combined with GN pinion motors of frame size 80 mm (3.15 in.)
②	LS: LS Linear Head
③	Traveling Direction of Rack F: The rack travels vertically to the mounting flange B: The rack travels horizontally to the mounting flange
④	Basic Speed of Rack 10: 10 mm/s (0.39 inch/s) 20: 20 mm/s (0.79 inch/s) 45: 45 mm/s (1.77 inch/s)
⑤	Stroke 1: 100 mm (3.94 in.) 2: 200 mm (7.87 in.) 3: 300 mm (11.81 in.) 4: 400 mm (15.75 in.) 5: 500 mm (19.69 in.) 6: 600 mm (23.62 in.) 7: 700 mm (27.56 in.) 8: 800 mm (31.50 in.) 9: 900 mm (35.43 in.) 10: 1000 mm (39.37 in.)

LS Linear Heads

2LS Type

Maximum Transportable Mass: 30 kg (66 lb.)

The maximum transportable mass varies with basic speed and the motor combined.



Vertical Stroke: **F** Type

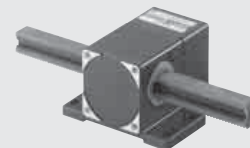

Horizontal Stroke: **B** Type

Product Line

Model	Model	Model
2LS□10-1	2LS□20-1	2LS□45-1
2LS□10-2	2LS□20-2	2LS□45-2
2LS□10-3	2LS□20-3	2LS□45-3
2LS□10-4	2LS□20-4	2LS□45-4
2LS□10-5	2LS□20-5	2LS□45-5
2LS□10-6	2LS□20-6	2LS□45-6
2LS□10-7	2LS□20-7	2LS□45-7
2LS□10-8	2LS□20-8	2LS□45-8

● Enter **F** or **B** (traveling direction of rack) in the box (□) within the model name.

The following items are included in each product.
Linear Head, Operating Manual

Specifications

Linear Head Specifications (RoHS)

Model	Vertical (F) Type	2LSF10-□	2LSF20-□	2LSF45-□
	Horizontal (B) Type	2LSB10-□	2LSB20-□	2LSB45-□
Basic Speed	mm/s (inch/s)	10 (0.39)	20 (0.79)	45 (1.77)
Stroke	mm (inch)	100 (3.94), 200 (7.87), 300 (11.81), 400 (15.75), 500 (19.69), 600 (23.62), 700 (27.56), 800 (31.50)		

- Enter the stroke in the box (□) within the model name.
- Basic speed is reference value based on the motor synchronous speed (1500 r/min at 50 Hz).
The actual rack speed varies with the load and power supply frequency.

Permissible Rack Rotating Torque (Moment)

0.3 N·m (2.6 lb-in) or less

Overrun

Refer to page F-66 of technical reference for overrun values.

Permissible Overhung Load

Stroke mm (inch)	Permissible Overhung Load N (lb.)
100 (3.94)	55 (12.3)
200 (7.87)	40 (9.0)
300 (11.81)	30 (6.7)
400 (15.75)	25 (5.6)
500 (19.69)	20 (4.5)
600 (23.62)	15 (3.3)
700 (27.56)	12 (2.7)
800 (31.50)	8 (1.8)

Applicable Products

Application	Applicable Product	Single-Phase 110/115 VAC	Single-Phase 220/230 VAC	Three-Phase 200/220/230 VAC	Page
Constant Speed	Reversible motor*1	2RK6GN-AW2U	2RK6GN-CW2E	—	A-86
Position Holding	Electromagnetic brake motor*1	2RK6GN-AW2MU	2RK6GN-CW2ME	2IK6GN-SW2M	A-116
Variable Speed	Speed control motor	ES01/2RK6RGN-AW2U	ES02/2RK6RGN-CW2E	—	B-172
Pushing*2	Torque motor	2TK3GN-AW2U	2TK3GN-CW2E	—	A-231

*1 Single-phase motors can be combined with the brake pack **SB50W** capable of instantaneous stop, bi-directional operation and electromagnetic brake control.
Brake pack **SB50W** → Page A-277

*2 Do not hit and stop an object because the output torque becomes very large while using a motor in a constrained operation. It may cause damage to the linear head due to the impact.

● The characteristics when combined with applicable product can be found using the formula shown on "characteristics of linear heads." Technical reference → Page F-65

Note:

- When the decimal gearhead **2GN10XS** is used, use the mounting screws included with the decimal gearhead.

Examples of Characteristics When Combined with Each Motor

Reversible Motors

Applicable Motor		Linear Head Model		2LSF10-□ 2LSB10-□		2LSF20-□ 2LSB20-□		2LSF45-□ 2LSB45-□	
Motor Model	Power Supply Input		Max. Transportable Mass kg (lb.)	Holding Force N (lb.)	Max. Transportable Mass kg (lb.)	Holding Force N (lb.)	Max. Transportable Mass kg (lb.)	Holding Force N (lb.)	
	Voltage VAC	Frequency Hz							
2RK6GN-AW2U	Single-Phase 110	60	30 (66)	81 (18.2)	15 (33)	33 (7.4)	9 (19.8)	16 (3.6)	
	Single-Phase 115		30 (66)	81 (18.2)	15 (33)	33 (7.4)	9 (19.8)	16 (3.6)	
2RK6GN-CW2E	Single-Phase 220	50	30 (66)	81 (18.2)	17 (37)	33 (7.4)	9.7 (21)	16 (3.6)	
		60	30 (66)	81 (18.2)	15 (33)	33 (7.4)	9 (19.8)	16 (3.6)	
	Single-Phase 220	50	30 (66)	81 (18.2)	19 (41)	33 (7.4)	10 (22)	16 (3.6)	
		60	30 (66)	81 (18.2)	15 (33)	33 (7.4)	9 (19.8)	16 (3.6)	

- Enter the stroke in the box (□) within the model name.
- The maximum load mass that can be driven when operating the rack vertically is the maximum transportable mass less the rack mass.
The holding force when operating the rack vertically is the holding force less the force calculated by multiplying rack mass (kg) by 9.807.
- Holding force is provided by the built-in friction brake of the reversible motor. The values vary depending on the temperature and the time of operation (reference values).

Electromagnetic Brake Motors

Applicable Motor		Linear Head Model		2LSF10-□ 2LSB10-□		2LSF20-□ 2LSB20-□		2LSF45-□ 2LSB45-□	
Motor Model	Power Supply Input		Max. Transportable Mass kg (lb.)	Holding Force N (lb.)	Max. Transportable Mass kg (lb.)	Holding Force N (lb.)	Max. Transportable Mass kg (lb.)	Holding Force N (lb.)	
	Voltage VAC	Frequency Hz							
2RK6GN-AW2MU	Single-Phase 110	60	30 (66)	300 (67)	15 (33)	190 (42)	9 (19.8)	99 (22)	
	Single-Phase 115		30 (66)	300 (67)	15 (33)	190 (42)	9 (19.8)	99 (22)	
2RK6GN-CW2ME	Single-Phase 220	50	30 (66)	300 (67)	19 (41)	190 (42)	10 (22)	99 (22)	
		60	30 (66)	300 (67)	15 (33)	190 (42)	9 (19.8)	99 (22)	
	Single-Phase 230	50	30 (66)	300 (67)	19 (41)	190 (42)	10 (22)	99 (22)	
		60	30 (66)	300 (67)	15 (33)	190 (42)	9 (19.8)	99 (22)	
2IK6GN-SW2M	Three-Phase 200	50	30 (66)	300 (67)	19 (41)	190 (42)	10 (22)	99 (22)	
		60	30 (66)	300 (67)	15 (33)	190 (42)	9 (19.8)	99 (22)	
	Three-Phase 220/230	60	30 (66)	300 (67)	15 (33)	190 (42)	9 (19.8)	99 (22)	

- Enter the stroke in the box (□) within the model name.
- The maximum load mass that can be driven when operating the rack vertically is the maximum transportable mass less the rack mass.
The holding force when operating the rack vertically is the holding force less the force calculated by multiplying rack mass (kg) by 9.807.
- When operating the mechanism horizontally supported the load by a guide, ensure that the load mass is less than the maximum transportable mass.

● Speed Control Motors

Linear Head Model	Motor Model	Power Supply Input		Variable Speed Range mm/s (inch/s) [r/min]	Max. Transportable Mass		Holding Force N (lb.)	
		Voltage VAC	Frequency Hz		Set Speed mm/s (inch/s) [r/min]	Transportable Mass kg (lb.)		
2LSF10-□ 2LSB10-□	ES01/ 2RK6RGN-AW2U	Single-Phase 110	60	0.6~10 (0.02~0.39) [90~1600]	0.6 (0.02) [90]	30 (66)	81 (18.2)	
		Single-Phase 115			7.7 (0.30) [1200]	30 (66)	81 (18.2)	
	ES02/ 2RK6RGN-CW2E	Single-Phase 220	50	0.6~9 (0.02~0.35) [90~1400]	0.6 (0.02) [90]	30 (66)	81 (18.2)	
			60	0.6~10 (0.02~0.39) [90~1600]	7.7 (0.30) [1200]	30 (66)	81 (18.2)	
		Single-Phase 230	50	0.6~9 (0.02~0.35) [90~1400]	0.6 (0.02) [90]	30 (66)	81 (18.2)	
			60	0.6~10 (0.02~0.39) [90~1600]	7.7 (0.30) [1200]	30 (66)	81 (18.2)	
	2LSF20-□ 2LSB20-□	ES01/ 2RK6RGN-AW2U	Single-Phase 110	60	1.4~25 (0.05~0.98) [90~1600]	1.5 (0.05) [90]	17 (37)	33 (7.4)
			Single-Phase 115			19 (0.74) [1200]	17 (37)	33 (7.4)
ES02/ 2RK6RGN-CW2E		Single-Phase 220	50	1.4~22 (0.05~0.86) [90~1400]	1.5 (0.05) [90]	17 (37)	33 (7.4)	
			60	1.4~25 (0.05~0.98) [90~1600]	19 (0.74) [1200]	19 (41)	33 (7.4)	
		Single-Phase 230	50	1.4~22 (0.05~0.86) [90~1400]	1.5 (0.05) [90]	19 (41)	33 (7.4)	
			60	1.4~25 (0.05~0.98) [90~1600]	19 (0.74) [1200]	17 (37)	33 (7.4)	
		ES01/ 2RK6RGN-AW2U	Single-Phase 110	60	2.8~50 (0.11~1.96) [90~1600]	2.9 (0.11) [90]	9.7 (21)	16 (3.6)
						38 (1.49) [1200]	9.7 (21)	16 (3.6)
Single-Phase 115			2.9 (0.11) [90]	9.7 (21)	16 (3.6)			
			38 (1.49) [1200]	9.7 (21)	16 (3.6)			
ES02/ 2RK6RGN-CW2E		Single-Phase 220	50	2.8~44 (0.11~1.73) [90~1400]	2.9 (0.11) [90]	9.7 (21)	16 (3.6)	
			60	2.8~50 (0.11~1.96) [90~1600]	38 (1.49) [1200]	9 (19.8)	16 (3.6)	
	Single-Phase 230	50	2.8~44 (0.11~1.73) [90~1400]	2.9 (0.11) [90]	11 (24)	16 (3.6)		
		60	2.8~50 (0.11~1.96) [90~1600]	38 (1.49) [1200]	11 (24)	16 (3.6)		
	ES01/ 2RK6RGN-AW2U	Single-Phase 110	60	2.8~50 (0.11~1.96) [90~1600]	2.9 (0.11) [90]	9.7 (21)	16 (3.6)	
					38 (1.49) [1200]	9.7 (21)	16 (3.6)	
ES02/ 2RK6RGN-CW2E	Single-Phase 115	60	2.8~50 (0.11~1.96) [90~1600]	2.9 (0.11) [90]	9.7 (21)	16 (3.6)		
				38 (1.49) [1200]	9.7 (21)	16 (3.6)		

- Enter the stroke in the box (□) within the model name.
- The maximum load mass that can be driven when operating the rack vertically is the maximum transportable mass less the rack mass.
The holding force when operating the rack vertically is the holding force less the force calculated by multiplying rack mass (kg) by 9.807.
- Holding force is provided by the built-in friction brake of the reversible motor. The values vary depending on the temperature and the time of operation (reference values).

Note:

- If the rack is moving up and down, speed control is disabled in downward moving. In these applications, use the full speed.

● Decimal Gearhead

Even when using a decimal gearhead, the maximum transportable mass and holding force do not change.

■ Direction of Rack Movement

→ Page A-275

Introduction

Induction Motors

Reversible Motors

Electro-magnetic Brake Motors

V Series

Clutch & Brake Motors

Synchronous Motors

Low-Speed Synchronous Motors

Waterlight, Dust-Resistant Motors

Torque Motors

Right-Angle Gearheads

Linear Heads

Brake Pack

Accessories

Installation

Dimensions Unit = mm (in.)

Linear Heads

Model	Total Length L mm (in.)	Mass (Rack mass included) kg (lb.)	Rack Mass kg (lb.)	DXF		When Photomicro Sensors are (Sold separately) Installed ①			When Limit Switches are (Sold separately) Installed ②		
				2LSF	2LSB	Effective Stroke mm (in.)	DXF		Effective Stroke mm (in.)	DXF	
							2LSF	2LSB		2LSF	2LSB
2LSF <input type="checkbox"/> -1 2LSB <input type="checkbox"/> -1	229.4±0.4 (9.031±0.016)	1.3 (2.9)	0.5 (1.10)	A514	A522	130 (5.12)	A657	A665	100 (3.94)	A530	A538
2LSF <input type="checkbox"/> -2 2LSB <input type="checkbox"/> -2	330±0.4 (12.992±0.016)	1.4 (3.1)	0.6 (1.32)	A515	A523	230 (9.06)	A658	A666	200 (7.87)	A531	A539
2LSF <input type="checkbox"/> -3 2LSB <input type="checkbox"/> -3	430.4±0.4 (16.945±0.016)	1.6 (3.5)	0.8 (1.76)	A516	A524	330 (12.99)	A659	A667	300 (11.81)	A532	A540
2LSF <input type="checkbox"/> -4 2LSB <input type="checkbox"/> -4	531±0.4 (20.906±0.016)	1.8 (4.0)	1.0 (2.2)	A517	A525	430 (16.93)	A660	A668	400 (15.75)	A533	A541
2LSF <input type="checkbox"/> -5 2LSB <input type="checkbox"/> -5	631.5±0.4 (24.862±0.016)	2.0 (4.4)	1.2 (2.6)	A518	A526	530 (20.87)	A661	A669	500 (19.69)	A534	A542
2LSF <input type="checkbox"/> -6 2LSB <input type="checkbox"/> -6	731.4±0.4 (28.795±0.016)	2.2 (4.8)	1.4 (3.1)	A519	A527	630 (24.80)	A662	A670	600 (23.62)	A535	A543
2LSF <input type="checkbox"/> -7 2LSB <input type="checkbox"/> -7	829.5±0.4 (32.657±0.016)	2.4 (5.3)	1.6 (3.5)	A520	A528	730 (28.74)	A663	A671	700 (27.56)	A536	A544
2LSF <input type="checkbox"/> -8 2LSB <input type="checkbox"/> -8	930.4±0.4 (36.630±0.016)	2.6 (5.7)	1.8 (4.0)	A521	A529	830 (32.68)	A664	A672	800 (31.50)	A537	A545

● Enter the basic speed in the box () within the model name.

● Photomicro sensor set **PARP-PS2** (sold separately) and limit switch set **PARP-MS** (sold separately) are available as accessories. → Page A-303

Notes:

- The effective stroke refers to the maximum stroke over which the rack can travel as follows:
- When photomicro sensor and shielding plate (sold separately) are used.
- When limit switches and dogs (sold separately) are used.
- If the load is installed on the limit switch side, the effective stroke becomes 15 mm (0.59 in.) shorter.

◇ **2LSF Type** Rack module 0.892 Pressure angle 20°

• When Photomicro Sensors are Installed ①

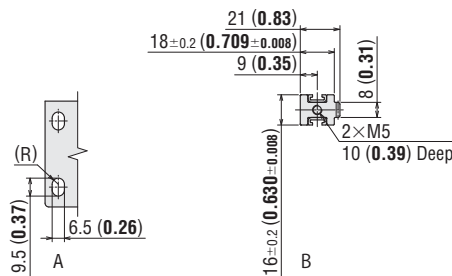
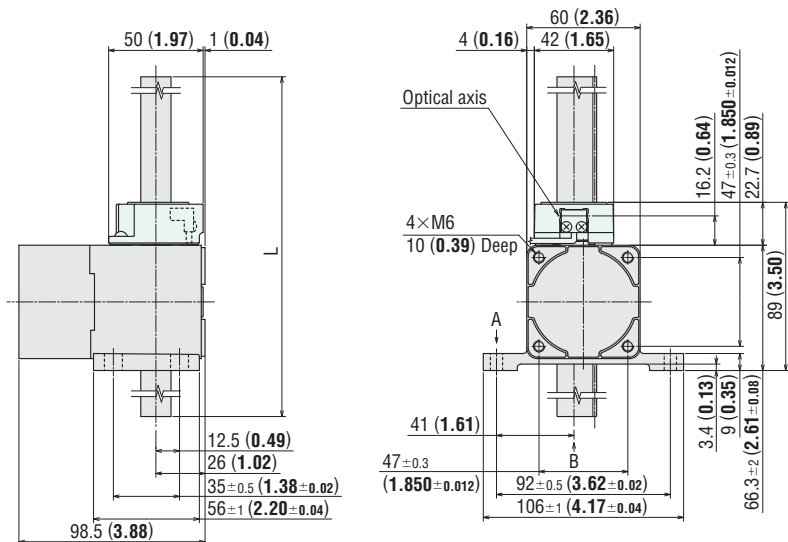

The colored area (□) indicates the area in which photomicro sensors (sold separately) are installed.

• When Limit Switches are Installed ②

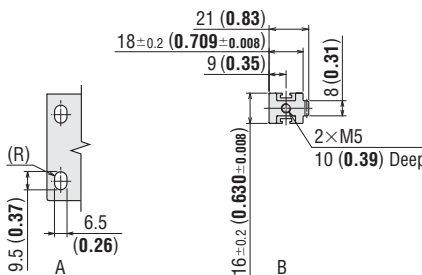
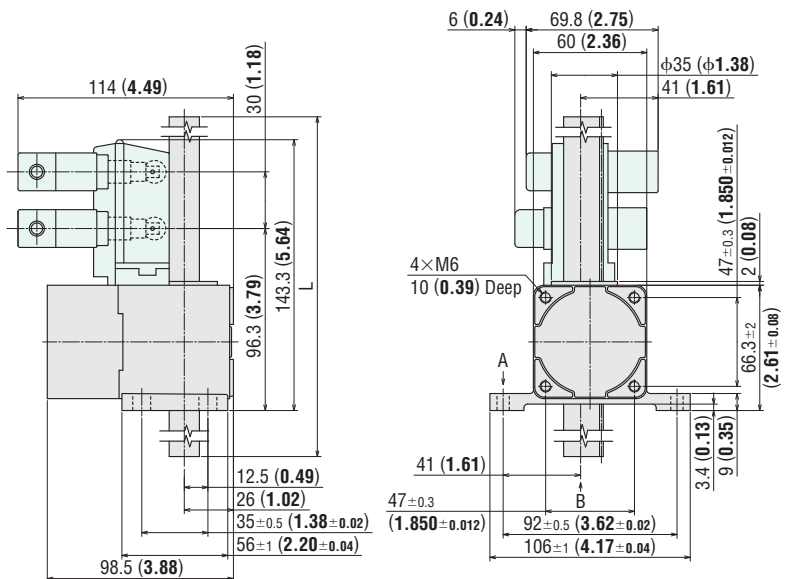

The colored area (□) indicates the area in which limit switches (sold separately) are installed.

- Introduction
- Induction Motors
- Reversible Motors
- Electromagnetic Brake Motors
- V Series
- Clutch & Brake Motors
- Synchronous Motors
- Low-Speed Synchronous Motors
- Waterlight, Dust-Resistant Motors
- Torque Motors
- Right-Angle Gearheads
- Linear Heads
- Brake Pack
- Accessories
- Installation

◇ **2LSB Type** Rack module 0.892 Pressure angle 20°

● **When Photomicro Sensors are Installed ①**

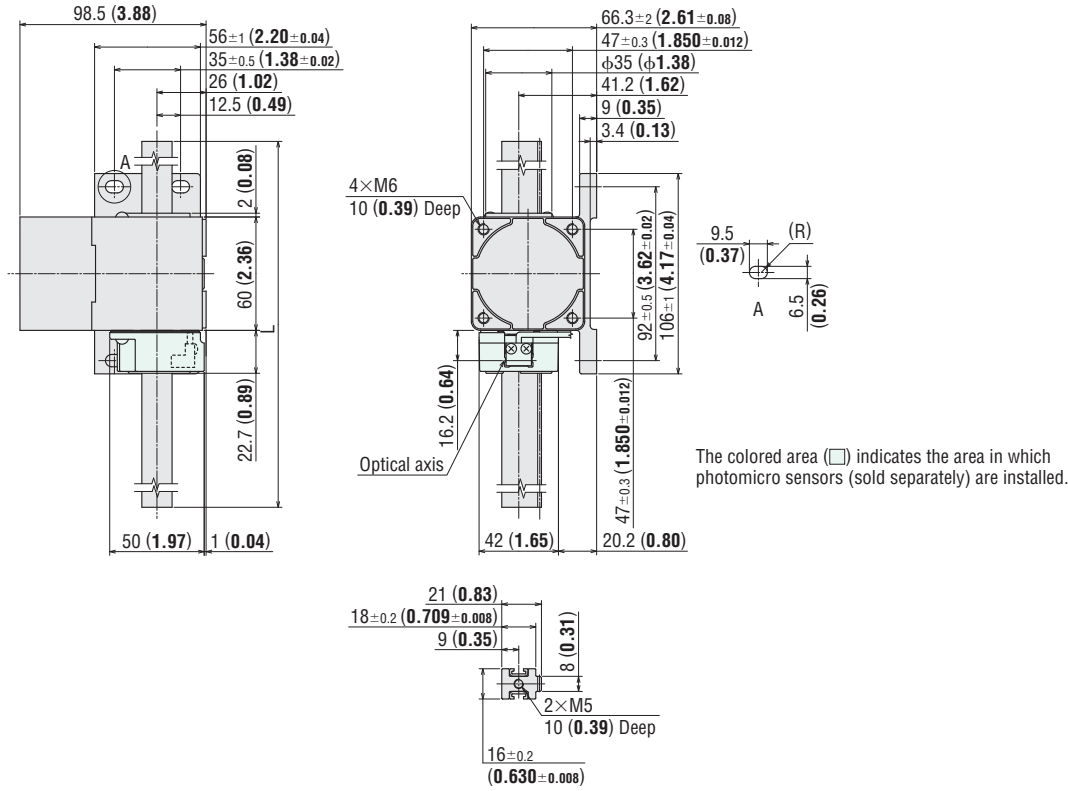

● **When Limit Switches are Installed ②**

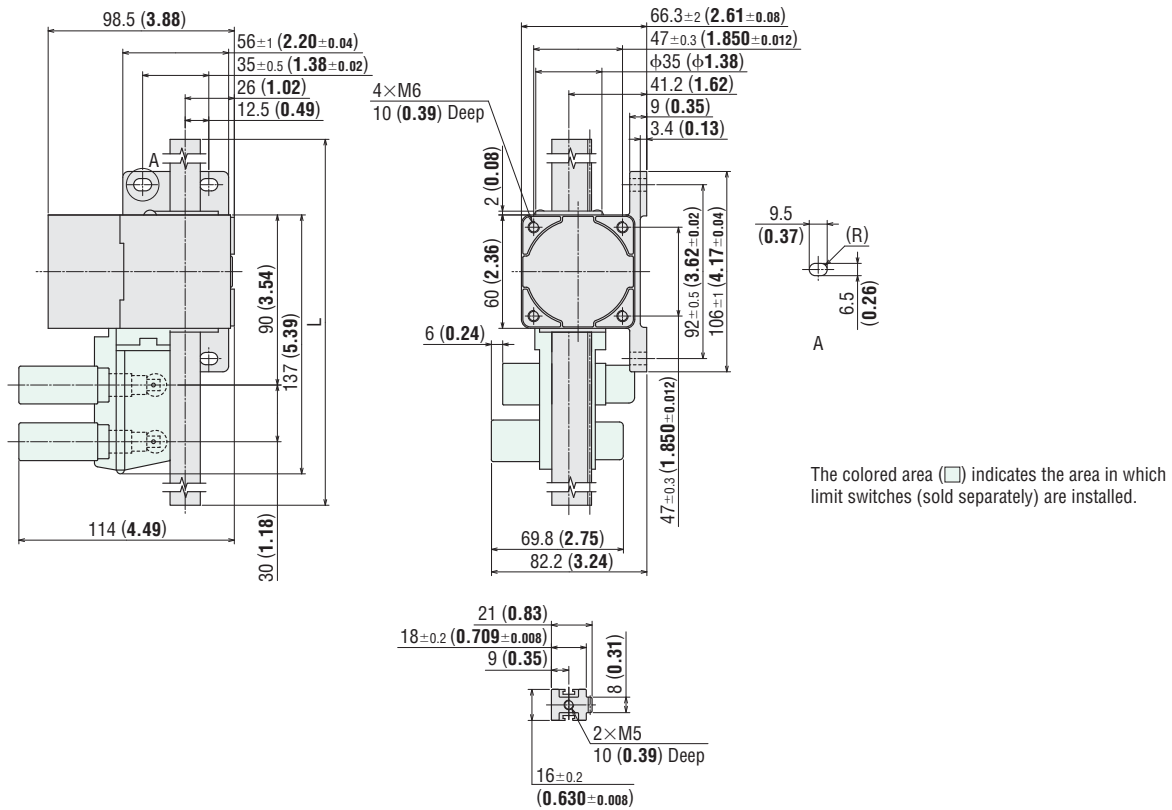

LS Linear Heads

4LS Type

Maximum Transportable Mass: 100 kg (220 lb.)

The maximum transportable mass varies with basic speed and the motor combined.

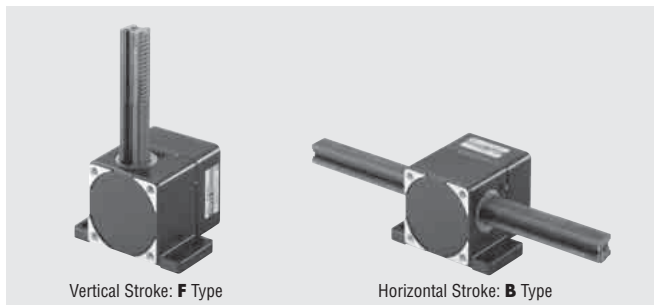
Vertical Stroke: **F** TypeHorizontal Stroke: **B** Type

Product Line

Model	Model	Model
4LS□10-1	4LS□20-1	4LS□45-1
4LS□10-2	4LS□20-2	4LS□45-2
4LS□10-3	4LS□20-3	4LS□45-3
4LS□10-4	4LS□20-4	4LS□45-4
4LS□10-5	4LS□20-5	4LS□45-5
4LS□10-6	4LS□20-6	4LS□45-6
4LS□10-7	4LS□20-7	4LS□45-7
4LS□10-8	4LS□20-8	4LS□45-8
4LS□10-9	4LS□20-9	4LS□45-9
4LS□10-10	4LS□20-10	4LS□45-10

● Enter **F** or **B** (traveling direction of rack) in the box (□) within the model name.

The following items are included in each product.
Linear Head, Operating Manual

Specifications

Linear Head Specifications (RoHS)

Model	Vertical (F) Type	4LSF10-□	4LSF20-□	4LSF45-□
	Horizontal (B) Type	4LSB10-□	4LSB20-□	4LSB45-□
Basic Speed	mm/s (inch/s)	10 (0.39)	20 (0.79)	45 (1.77)
Stroke	mm (inch)	100 (3.94), 200 (7.87), 300 (11.81), 400 (15.75), 500 (19.69), 600 (23.62), 700 (27.56), 800 (31.50), 900 (35.43), 1000 (39.37)		

- Enter the stroke in the box (□) within the model name.
- Basic speed is reference value based on the motor synchronous speed (1500 r/min at 50 Hz).
The actual speed varies with the load and power supply frequency.

Permissible Rack Rotating Torque (Moment)

0.5 N·m (4.4 lb-in) or less

Overrun

Refer to page F-66 of technical reference for overrun values.

Permissible Overhung Load

Stroke mm (inch)	Permissible Overhung Load N (lb.)
100 (3.94)	120 (27)
200 (7.87)	90 (20)
300 (11.81)	70 (15.7)
400 (15.75)	60 (13.5)
500 (19.69)	50 (11.2)
600 (23.62)	40 (9.0)
700 (27.56)	40 (9.0)
800 (31.50)	25 (5.6)
900 (35.43)	20 (4.5)
1000 (39.37)	15 (3.3)

Applicable Products

Application	Applicable Product	Single-Phase 110/115 VAC	Single-Phase 220/230 VAC	Three-Phase 200/220/230 VAC	Page
Constant Speed	Reversible motor*1	Lead wire type	4RK25GN-AW2U	4RK25GN-CW2E	A-92
		Terminal box type	4RK25GN-AW2TU	4RK25GN-CW2TE	
Position Holding	Electromagnetic brake motor*1	4RK25GN-AW2MU	4RK25GN-CW2ME	4IK25GN-SW2M	A-124
Variable Speed	Speed control motor	ES01/4RK25RGN-AW2U	ES02/4RK25RGN-CW2E	—	B-172
Pushing*2	Torque motor	4TK10GN-AW2U	4TK10GN-CW2E	—	A-231

*1 Single-phase motors can be combined with the brake pack **SB50W** capable of instantaneous stop, bi-directional operation and electromagnetic brake control.
Brake Pack **SB50W** → Page A-277

*2 Do not hit and stop an object because the output torque becomes very large while using a motor in a constrained operation. It may cause damage to the linear head due to the impact.

● The characteristics when combined with applicable product can be found using the formula shown on "characteristics of linear heads." Technical reference → Page F-65

Note:

● When the decimal gearhead **4GN10XS** is used, use the mounting screws included with the decimal gearhead.

Examples of Characteristics When Combined with Each Motor

● Reversible Motors

Applicable Motor			Linear Head Model		4LSF10-□ 4LSB10-□		4LSF20-□ 4LSB20-□		4LSF45-□ 4LSB45-□	
Motor Model	Power Supply Input		Max. Transportable Mass kg (lb.)	Holding Force N (lb.)	Max. Transportable Mass kg (lb.)	Holding Force N (lb.)	Max. Transportable Mass kg (lb.)	Holding Force N (lb.)	Max. Transportable Mass kg (lb.)	Holding Force N (lb.)
	Voltage VAC	Frequency Hz								
4RK25GN-AW2U 4RK25GN-AW2TU	Single-Phase 110	60	100 (220)	210 (47)	58 (127)	100 (22)	31 (68)	50 (11.2)		
	Single-Phase 115		100 (220)	210 (47)	58 (127)	100 (22)	31 (68)	50 (11.2)		
4RK25GN-CW2E 4RK25GN-CW2TE	Single-Phase 220	50	100 (220)	210 (47)	58 (127)	100 (22)	31 (68)	50 (11.2)		
		60	100 (220)	210 (47)	58 (127)	100 (22)	31 (68)	50 (11.2)		
	Single-Phase 230	50	100 (220)	210 (47)	66 (145)	100 (22)	35 (77)	50 (11.2)		
		60	100 (220)	210 (47)	58 (127)	100 (22)	31 (68)	50 (11.2)		

- Enter the stroke in the box (□) within the model name.
- The maximum load mass that can be driven when operating the rack vertically is the maximum transportable mass less the rack mass.
The holding force when operating the rack vertically is the holding force less the force calculated by multiplying rack mass (kg) by 9.807.
- Holding force is provided by the built-in friction brake of the reversible motor. The values vary depending on the temperature and the time of operation (reference values).

● Electromagnetic Brake Motors

Applicable Motor			Linear Head Model		4LSF10-□ 4LSB10-□		4LSF20-□ 4LSB20-□		4LSF45-□ 4LSB45-□	
Motor Model	Power Supply Input		Max. Transportable Mass kg (lb.)	Holding Force N (lb.)	Max. Transportable Mass kg (lb.)	Holding Force N (lb.)	Max. Transportable Mass kg (lb.)	Holding Force N (lb.)	Max. Transportable Mass kg (lb.)	Holding Force N (lb.)
	Voltage VAC	Frequency Hz								
4RK25GN-AW2MU	Single-Phase 110	60	100 (220)	1000 (220)	58 (127)	700 (157)	31 (68)	330 (74)		
	Single-Phase 115		100 (220)	1000 (220)	58 (127)	700 (157)	31 (68)	330 (74)		
4RK25GN-CW2ME	Single-Phase 220	50	100 (220)	1000 (220)	66 (145)	700 (157)	35 (77)	330 (74)		
		60	100 (220)	1000 (220)	58 (127)	700 (157)	31 (68)	330 (74)		
	Single-Phase 230	50	100 (220)	1000 (220)	66 (145)	700 (157)	35 (77)	330 (74)		
		60	100 (220)	1000 (220)	58 (127)	700 (157)	31 (68)	330 (74)		
4IK25GN-SW2M	Three-Phase 200	50	100 (220)	1000 (220)	81 (178)	700 (157)	43 (94)	330 (74)		
		60	100 (220)	1000 (220)	66 (145)	700 (157)	35 (77)	330 (74)		
	Three-Phase 220/230	60	100 (220)	1000 (220)	64 (140)	700 (157)	34 (74)	330 (74)		

- Enter the stroke in the box (□) within the model name.
- The maximum load mass that can be driven when operating the rack vertically is the maximum transportable mass less the rack mass.
The holding force when operating the rack vertically is the holding force less the force calculated by multiplying rack mass (kg) by 9.807.
- When operating the mechanism horizontally supported the load by a guide, ensure that the load mass is less than the maximum transportable mass.

● Speed Control Motors

Linear Head Model	Motor Model	Power Supply Input		Variable Speed Range mm/s (inch/s) [r/min]	Max. Transportable Mass		Holding Force N (lb.)		
		Voltage VAC	Frequency Hz		Set Speed mm/s (inch/s) [r/min]	Transportable Mass kg (lb.)			
4LSF10-□ 4LSB10-□	ES01/ 4RK25RGN-AW2U	Single-Phase 110	60	0.7~11 (0.02~0.43) [90~1600]	0.7 (0.22) [90]	94 (200)	210 (47)		
		Single-Phase 115			8.9 (0.35) [1200]	100 (220)	210 (47)		
	ES02/ 4RK25RGN-CW2E	Single-Phase 220	50	0.7~10 (0.02~0.39) [90~1400]	0.7 (0.22) [90]	98 (210)	210 (47)		
			60	0.7~11 (0.02~0.43) [90~1600]	8.9 (0.35) [1200]	100 (220)	210 (47)		
		Single-Phase 230	50	0.7~10 (0.02~0.39) [90~1400]	0.7 (0.22) [90]	98 (210)	210 (47)		
			60	0.7~11 (0.02~0.43) [90~1600]	8.9 (0.35) [1200]	100 (220)	210 (47)		
		4LSF20-□ 4LSB20-□	ES01/ 4RK25RGN-AW2U	Single-Phase 110	60	1.4~23 (0.05~0.90) [90~1600]	1.4 (0.05) [90]	45 (99)	100 (22)
				Single-Phase 115			18 (0.70) [1200]	58 (127)	100 (22)
ES02/ 4RK25RGN-CW2E	Single-Phase 220		50	1.4~20 (0.05~0.78) [90~1400]	1.4 (0.05) [90]	47 (103)	100 (22)		
			60	1.4~23 (0.05~0.90) [90~1600]	18 (0.70) [1200]	58 (127)	100 (22)		
	Single-Phase 230		50	1.4~20 (0.05~0.78) [90~1400]	1.4 (0.05) [90]	47 (103)	100 (22)		
			60	1.4~23 (0.05~0.90) [90~1600]	18 (0.70) [1200]	64 (140)	100 (22)		
	4LSF45-□ 4LSB45-□		ES01/ 4RK25RGN-AW2U	Single-Phase 110	60	2.8~49 (0.11~1.92) [90~1600]	2.8 (0.11) [90]	24 (52)	50 (11.2)
				Single-Phase 115			37 (1.45) [1200]	30 (66)	50 (11.2)
ES02/ 4RK25RGN-CW2E		Single-Phase 220	50	2.8~43 (0.11~1.69) [90~1400]	2.8 (0.11) [90]	25 (55)	50 (11.2)		
			60	2.8~49 (0.11~1.92) [90~1600]	37 (1.45) [1200]	30 (66)	50 (11.2)		
		Single-Phase 230	50	2.8~43 (0.11~1.69) [90~1400]	2.8 (0.11) [90]	25 (55)	50 (11.2)		
			60	2.8~49 (0.11~1.92) [90~1600]	37 (1.45) [1200]	34 (74)	50 (11.2)		

- Enter the stroke in the box (□) within the model name.
 - The maximum load mass that can be driven when operating the rack vertically is the maximum transportable mass less the rack mass.
The holding force when operating the rack vertically is the holding force less the force calculated by multiplying rack mass (kg) by 9.807.
 - Holding force is provided by the built-in friction brake of the reversible motor. The values vary depending on the temperature and the time of operation (reference values).
- Note:**
- If the rack is moving up and down, speed control is disabled in downward moving. In these applications, use the full speed.

● Decimal Gearhead

Even when using a decimal gearhead, the maximum transportable mass and holding force do not change.

■ Direction of Rack Movement

→ Page A-275

Introduction

Induction Motors

Reversible Motors

Electro-magnetic Brake Motors

V Series

Clutch & Brake Motors

Synchronous Motors

Low-Speed Synchronous Motors

Waterlight, Dust-Resistant Motors

Torque Motors

Right-Angle Gearheads

Linear Heads

Brake Pack

Accessories

Installation

Dimensions Unit = mm (in.)

Linear Heads

Model	Total Length L mm (in.)	Mass (Rack mass included) kg (lb.)	Rack Mass kg (lb.)	DXF		When Photomicro Sensors are (Sold separately) Installed ①			When Limit Switches are (Sold separately) Installed ②		
				4LSF	4LSB	Effective Stroke mm (in.)	DXF		Effective Stroke mm (in.)	DXF	
							4LSF	4LSB		4LSF	4LSB
4LSF□-1 4LSB□-1	243.5±0.4 (9.587±0.016)	1.9 (4.2)	0.7 (1.54)	A546	A556	120 (4.72)	A673	A683	95 (3.74)	A566	A576
4LSF□-2 4LSB□-2	341.6±0.4 (13.449±0.016)	2.2 (4.8)	1.0 (2.2)	A547	A557	220 (8.66)	A674	A684	195 (7.68)	A567	A577
4LSF□-3 4LSB□-3	443.7±0.4 (17.469±0.016)	2.5 (5.5)	1.3 (2.9)	A548	A558	320 (12.60)	A675	A685	295 (11.61)	A568	A578
4LSF□-4 4LSB□-4	541.9±0.4 (21.335±0.016)	2.7 (5.9)	1.5 (3.3)	A549	A559	420 (16.54)	A676	A686	395 (15.55)	A569	A579
4LSF□-5 4LSB□-5	640.1±0.4 (25.201±0.016)	3.0 (6.6)	1.8 (4.0)	A550	A560	520 (20.47)	A677	A687	495 (19.49)	A570	A580
4LSF□-6 4LSB□-6	742.2±0.4 (29.220±0.016)	3.3 (7.3)	2.1 (4.6)	A551	A561	620 (24.41)	A678	A688	595 (23.43)	A571	A581
4LSF□-7 4LSB□-7	840.4±0.4 (33.087±0.016)	3.6 (7.9)	2.4 (5.3)	A552	A562	720 (28.35)	A679	A689	695 (27.36)	A572	A582
4LSF□-8 4LSB□-8	942.5±0.4 (37.106±0.016)	3.9 (8.6)	2.7 (5.9)	A553	A563	820 (32.28)	A680	A690	795 (31.30)	A573	A583
4LSF□-9 4LSB□-9	1040.7±0.8 (40.972±0.031)	4.2 (9.2)	3.0 (6.6)	A554	A564	920 (36.22)	A681	A691	895 (35.24)	A574	A584
4LSF□-10 4LSB□-10	1142.8±0.8 (44.992±0.031)	4.5 (9.9)	3.3 (7.3)	A555	A565	1020 (40.16)	A682	A692	995 (39.17)	A575	A585

● Enter the basic speed in the box (□) within the model name.

● Photomicro sensor set **PARP-PS4** (sold separately) and limit switch set **PARP-MS** (sold separately) are available as accessories. → Page A-303

Notes:

- The effective stroke refers to the maximum stroke over which the rack can travel as follows:
 - When photomicro sensor and shielding plate (sold separately) are used.
 - When limit switches and dogs (sold separately) are used.
- If the load is installed on the limit switch side, the effective stroke becomes 15 mm (0.59 in.) shorter.

◇ **4LSF Type** Rack module 1.25 Pressure angle 20°

● When Photomicro Sensors are Installed ①

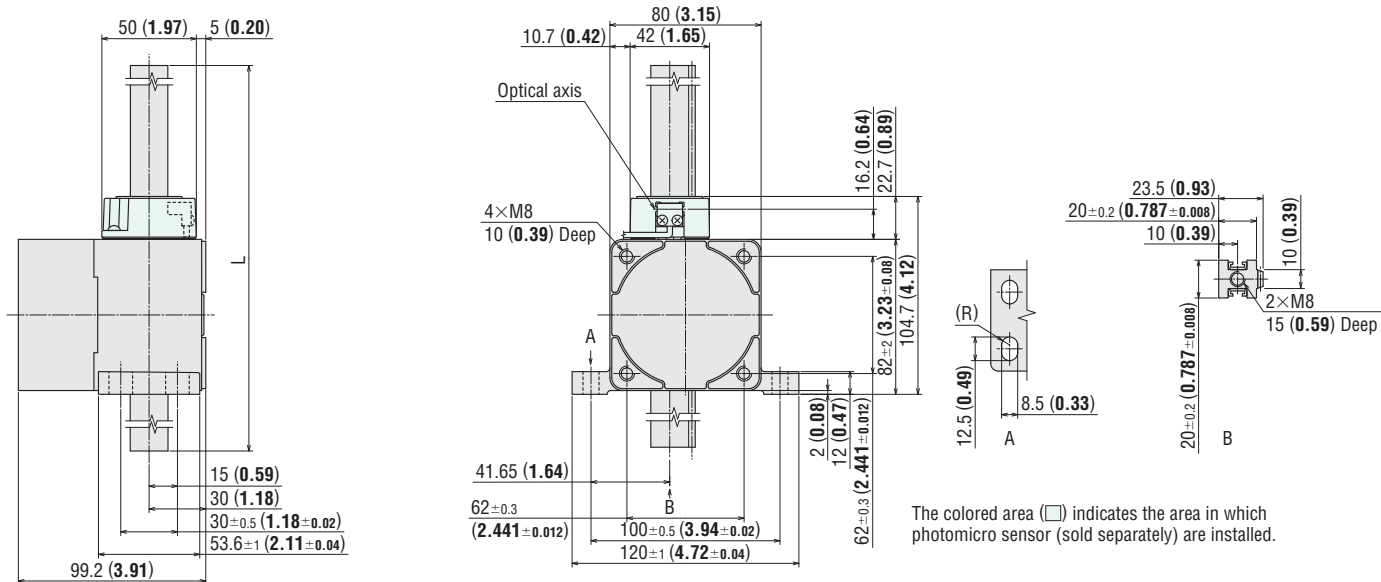

● When Limit Switches are Installed ②

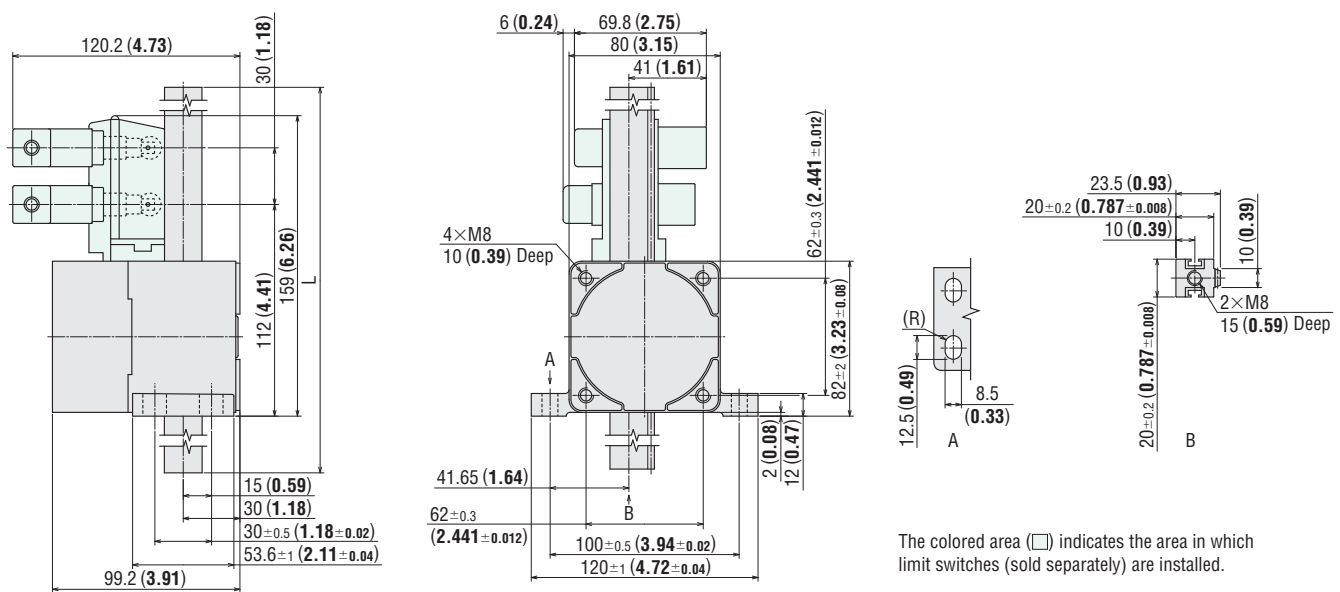

- Introduction
- Induction Motors
- Reversible Motors
- Electro-magnetic Brake Motors
- V Series
- Clutch & Brake Motors
- Synchronous Motors
- Low-Speed Synchronous Motors
- Waterlight, Dust-Resistant Motors
- Torque Motors
- Right-Angle Gearheads
- Linear Heads
- Brake Pack
- Accessories
- Installation

Direction of Rack Movement

The direction of rack movement is determined by the rotation direction of motor.

2LS Type

Model	Rotation Direction of Motor	
	Clockwise	Counterclockwise
2LSF10 -□ 2LSF45 -□	Down	Up
2LSB10 -□ 2LSB45 -□	Left	Right
2LSF20 -□ 2LSB20 -□	Up	Down
	Right	Left

4LS Type

Model	Rotation Direction of Motor	
	Clockwise	Counterclockwise
4LSF10 -□ 4LSF20 -□	Up	Down
4LSB10 -□ 4LSB20 -□	Right	Left
4LSF45 -□ 4LSB45 -□	Down	Up
	Left	Right

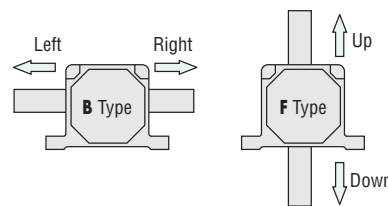

- Enter the stroke in the box (□) within the model name.
- Direction of rack movement is viewed from the linear head side.
- Even when using a decimal gearhead, the direction of rack movement does not change.

Connection Diagrams

Connection Example Using Photomicro Sensor (Sold separately)

Power supply voltage and current must be 5 to 24 VDC, 100 mA or below. If the current exceeds 100 mA, connect an external resistor R_0 . The GND of sensor power and power of external control device should be connected together.

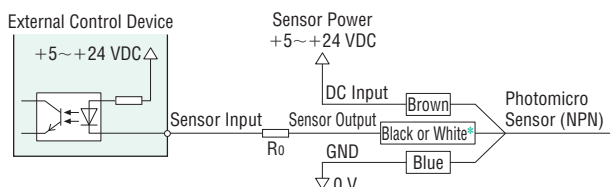

- * Connect the white lead when the sensor logic is N.O. (normally open), and connect the black lead when N.C. (normally closed)

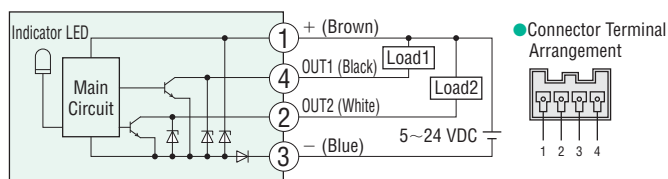

Connector Pin No.	Indication
1	+V
2	OUT2
3	0V
4	OUT1

Connection Example Using Limit Switches (Sold separately)

Shown below is an example of combining **2LSB10**-□ with the electromagnetic brake motor **2RK6GN-AW2MU** or **2RK6GN-CW2ME**. The direction of rack movement is viewed from the surface where the motor is assembled.

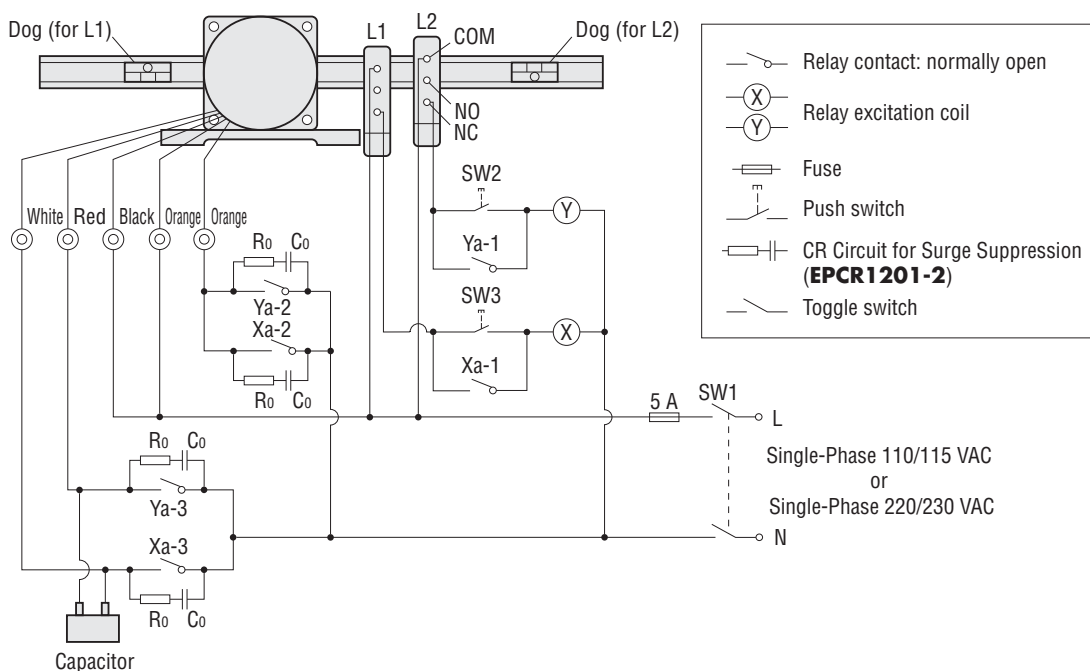

- SW1: Power supply
 SW2: Starts operation in right direction
 SW3: Starts operation in left direction
 L1: Stop signal in left direction
 L2: Stop signal in right direction
 Xa-1: For holding X
 Xa-2: For brake operation
 Xa-3: For rack operation in left direction
 Ya-1: For holding Y
 Ya-2: For brake operation
 Ya-3: For rack operation in right direction

- The contact capacity of each relay or switch should be at least 125 VAC 5 A or 250 VAC 5 A.

