

Speed Control

Connection and Operation (Speed Control)

Speed control can be implemented on the standard model, but extended function is available only when a control module **OPX-1A** is used.

Names and Functions of Driver Parts

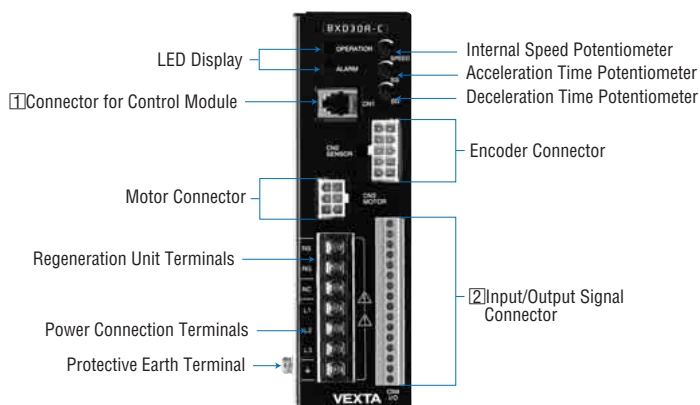

Connector for Control Module

You can extend the speed control performance by using an accessory control module **OPX-1A**.



Main Function

Setting Function	<ul style="list-style-type: none"> Speed (8 speed settings max.) Torque Limiting Values
Displaying Function	<ul style="list-style-type: none"> Speed (r/min) Load Factor (%) Alarm Code Alarm History

● Dimensions → Page B-58

Input/Output Signals

CN4 Terminal Number	I/O	Signal Name		Function
		Standard Model	Extended Function	
1	Input	CW	CW	CW rotation/stop switching input
2		CCW	CCW	CCW rotation/stop switching input
3		MO	MO	Internal speed setting/external analog setting
4		NC	M1	Standard model: Nothing is connected.
5		NC	M2	Extended function: Operation-data selection
6		FREE	FREE	Motor excitation cancellation, electromagnetic brake release
7		BRAKE/ ALARM-RESET	BRAKE/ ALARM-RESET	Normal: Brake input Protective function has been activated: Alarm reset input
8	IN-COM	IN-COM	Input signal common	
9	Analog Input	H	H	Speed setting by the external speed potentiometer or external DC voltage
10		M	M	
11		L	L	
12	Output	ALARM	ALARM	This signal is output when a protective function has been activated (normally closed).
13		BUSY/ ALARM-PULSE	BUSY (TLM)*/ ALARM-PULSE	Normal: Busy output Protective function has been activated: Alarm pulse output
14		ASG	ASG	500 pulses are output per motor rotation (phase difference output)
15		BSG	BSG	
16		OUT-COM	OUT-COM	Output signal common

* The BUSY output can be changed to the torque limiting (TLM) output only when a torque limit is set.

● Connection Diagrams

◇ Standard Model

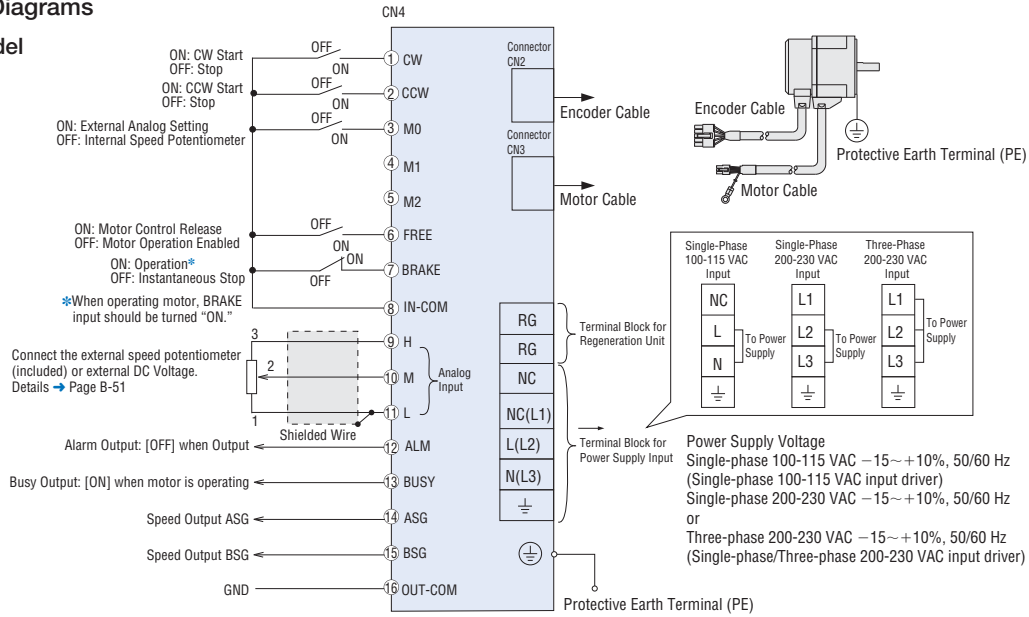

◇ When Using a Control Module

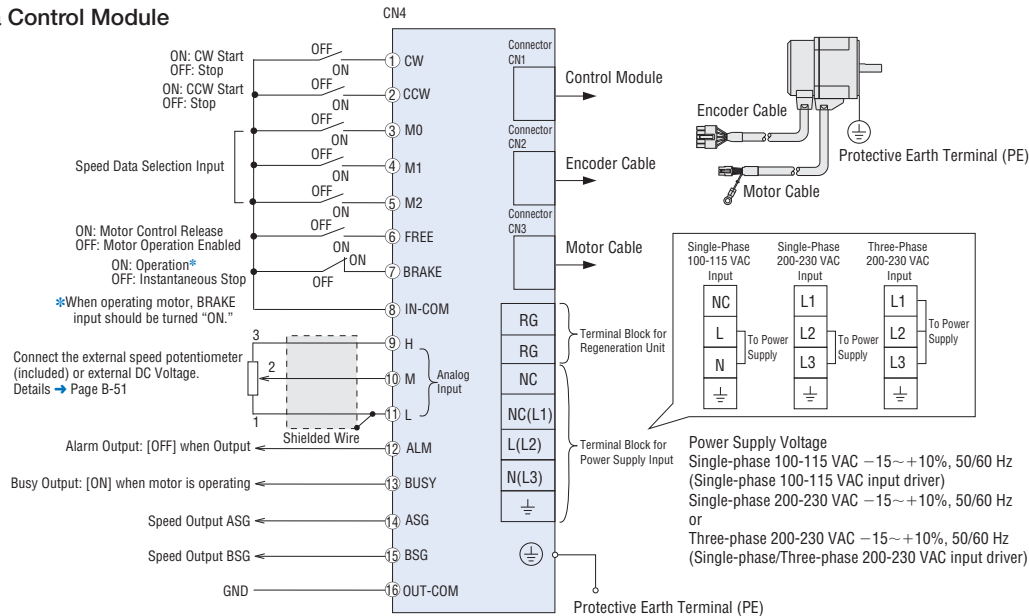

Notes:

- When it is necessary to have a connection more than 0.4 m (16 in.) between motor and driver, the accessory extension cable or flexible extension cable must be used.
- Use one of the following cables for the power supply line:
Single-Phase 100-115 VAC, 3-core cable [AWG18 (0.75 mm²) or thicker]
Single-Phase 200-230 VAC, 3-core cable [AWG18 (0.75 mm²) or thicker]
Three-Phase 200-230 VAC, 4-core cable [AWG18 (0.75 mm²) or thicker]
- When wiring the control I/O signal lines, keep a minimum distance of 300 mm (12 in.) from power lines (AC line, motor line and other largecurrent circuits). Also, do not route the control I/O signal lines in the same duct or piping as that is used for power lines.
- Cables for the power supply lines and control I/O signal lines are not supplied with the product. Provide appropriate cables separately.
- When grounding the driver, connect the ground wire to the protective earth terminal (M4) and connect the other end to a single point using a cable with a size of AWG18 (0.75 mm²) or thicker.

◇ Applicable Crimp Terminals

● Power Supply Terminals

● Round Terminal with Insulation (M3)

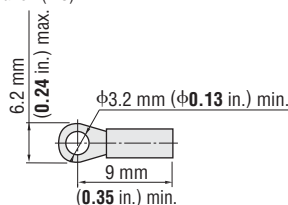

● I/O Terminals (CN4)

Use the terminals specified below for connection using crimp terminals. Please note that the applicable crimp terminal will vary depending on the size of the wire. The following terminals can be used with wires of AWG26 to 18 (0.14~0.75 mm²).

Manufacturer: Phoenix Contact

- AI 0.25-6 Applicable wire size: AWG26 to 24 (0.14 to 0.2 mm²)
- AI 0.5-6 Applicable wire size: AWG20 (0.5 mm²)
- AI 0.34-6 Applicable wire size: AWG22 (0.3 mm²)
- AI 0.75-6 Applicable wire size: AWG18 (0.75 mm²)

Speed Control

● Input/Output Signal Circuits (Common to standard model and using a control module)

◇ Input Circuit

The circled number located in front of each signal represents the number of the corresponding I/O signal terminal.

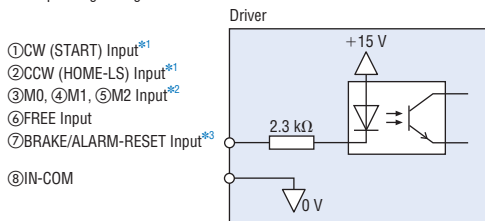

- *1 The CW and CCW inputs function in the speed control mode on the standard model and when the control module **OPX-1A** is used. The START and HOME-LS inputs function in the position control mode when the control module **OPX-1A** is used.
- *2 The M0 input is the only operation-data selection input available on the standard model. The M0, M1 and M2 inputs function when the control module **OPX-1A** is used.
- *3 This input functions as the BRAKE input during normal operation, and as the ALARM-RESET input when a driver protection is active.

◇ Output Circuit

The circled number located in front of each signal represents the number of the corresponding I/O signal terminal.

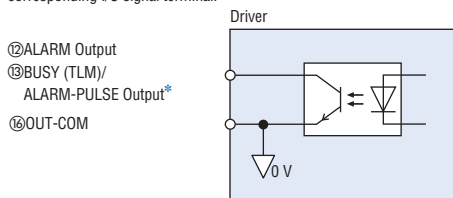

- * This output functions as the BUSY output during normal operation, and as the ALARM-PULSE output when a driver protection is active. When the control module **OPX-1A** is used, the BUSY output can be changed to the TLM output.

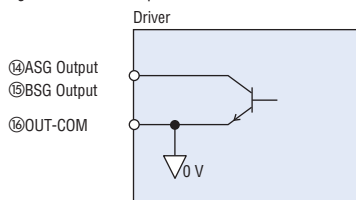

◇ When an External Control Device with a Built-In Clamp Diode is Used

When you want to use an external control device with a built-in clamp diode, pay attention to the sequence of turning on or off the power.

Power ON: External control device ON → Driver ON
 Power OFF: Driver OFF → External control device OFF

If the driver power is turned on first when connected as shown in the figure below, or the external control device power is turned off with the driver power turned on, current will be applied, as indicated by the arrows in the diagram. This may cause the motor to run. When the power is turned on or off simultaneously, the motor may run temporarily due to differences in power capacity. The external control device power must be turned on first, and driver power must be turned off first.

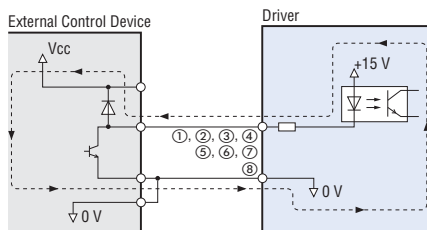

● Description of Input/Output Signals

Indication of Input/Output Signal "ON" "OFF"

Input (Output) "ON" indicates that the current is sent into the photocoupler (transistor) inside the driver. Input (Output) "OFF" indicates that the current is not sent into the photocoupler (transistor) inside the driver. The input/output remains "OFF" if nothing is connected.

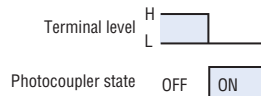

● Input Signals (Standard model)

◇ Clockwise Rotation (CW) Input

When the BRAKE input is ON, motor operation is enabled. If the CW input is turned ON, acceleration and operation are performed in the clockwise direction over the time set by the acceleration time potentiometer. If it is turned OFF, the motor decelerates and the operation stops over the time set by the deceleration time potentiometer.

◇ Counterclockwise Rotation (CCW) Input

When the BRAKE input is ON, motor operation is enabled. If the CCW input is turned ON, acceleration and operation are performed in the counterclockwise direction over the time set by the acceleration time potentiometer. If it is turned OFF, the motor decelerates and the operation stops over the time set by the deceleration time potentiometer.

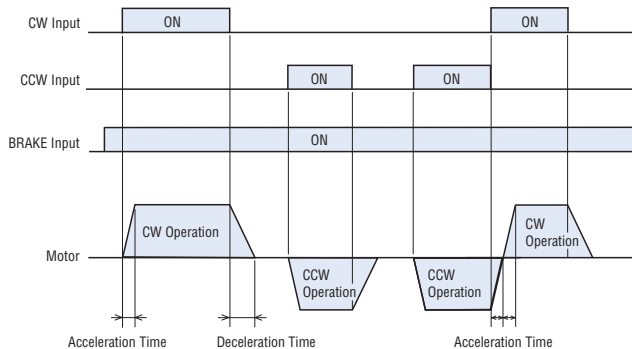

- If the rotation direction has been changed during motor operation, acceleration and deceleration will be performed over the time set by the acceleration time potentiometer.

Note:

- The rotation direction indicates the direction as viewed from the motor's output shaft. With the combination type, the rotation direction varies according to the gearhead ratio. Gearmotor – torque table of combination type → Page B-28
 Rotation direction of the hollow shaft flat gearhead → Page B-29

◇ Speed Control Data Selection (M0) Input

With the M0 input, the speed can be controlled by either the internal speed potentiometer or an external analog setting.

M0	Speed Setting
OFF	Internal Speed Potentiometer
ON	External Analog Setting

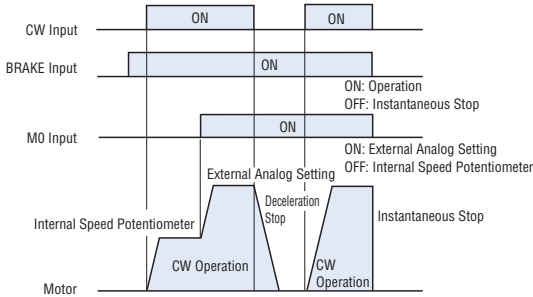

● Switching to a lower speed using the M0 input while the motor is operating will cause the motor to decelerate over the time set by the acceleration time potentiometer, not the time set by the deceleration time potentiometer.

◇ Motor Control Release (FREE) Input

When the photocoupler is turned ON, the motor excitation is cancelled and the electromagnetic brake is released. The FREE input is given the highest priority regardless of the condition of other inputs. The FREE input functions even when a protective function is activated.

◇ Brake (BRAKE)/Alarm Reset (ALARM-RESET) Input

This input functions as the BRAKE input during normal operation, and as the ALARM-RESET input when a driver protective function is active.

● During Normal Operation (BRAKE input)

When the BRAKE input is turned ON, motor operation is enabled. If it is turned OFF, the motor is stopped instantaneously. To start motor operation, be sure to set the BRAKE input to ON.

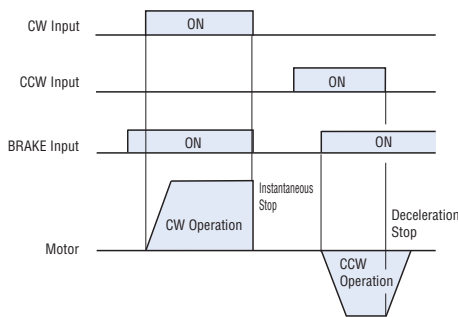

● Upon Activation of a Protective Function (ALARM-RESET input)

The activated protective function is reset and the driver is restarted. This input is used to reset protective functions while power is supplied. Note, however, that if the protective function for overcurrent, EEPROM error or encoder error have been activated, they cannot be reset. If any of these protective functions have been activated, contact the nearest Oriental Motor sales office.

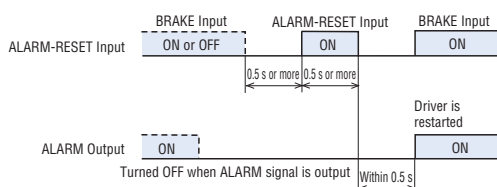

● Input Signals (When using a control module)

◇ Clockwise Rotation (CW) Input

◇ Counterclockwise Rotation (CCW) Input

◇ Motor Control Release (FREE) Input

◇ Brake (BRAKE)/Alarm Reset (ALARM-RESET) Input same as Input Signals (Standard model)

◇ Speed Control Data Selection (M0, M1, M2) Input

The particular combination of the M0, M1 and M2 inputs selects a maximum of eight sets of speed data. (Common to speed control mode and position control mode)

Speed Control Data	Speed Control Data Selection			Method of Speed Setting
	M0	M1	M2	
No.0	OFF	OFF	OFF	Internal speed potentiometer/ Digital setting
No.1	ON	OFF	OFF	External analog/ Digital setting
No.2	OFF	ON	OFF	Digital setting
No.3	ON	ON	OFF	Digital setting
No.4	OFF	OFF	ON	Digital setting
No.5	ON	OFF	ON	Digital setting
No.6	OFF	ON	ON	Digital setting
No.7	ON	ON	ON	Digital setting

Speed Control

● Output Signals (Standard model)

◇ Alarm (ALARM) Output

The transistor turns OFF when a driver protective function is active. When overload, overcurrent or other abnormality is detected, the alarm signal is output and the ALARM LED on the driver is blinked and the motor coasts to a stop. The electromagnetic brake will be activated. To reset the alarm signal output, resolve the cause of the problem and ensure the safety of the equipment and load. Then turn on the ALARM-RESET input or reconnect the power. When reconnecting the power, turn off the power and then wait for at least 30 seconds before turning it back on.

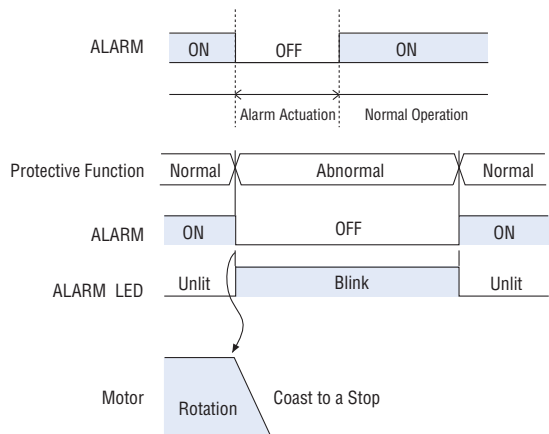

Note:

● The alarm output logic is opposite that of other signal outputs (positive logic output).

◇ Phase Difference (ASG/BSG) Output

Feedback pulses are output from the encoder (500 p/r). This output is used when monitoring the motor speed and position by connecting a counter, etc.

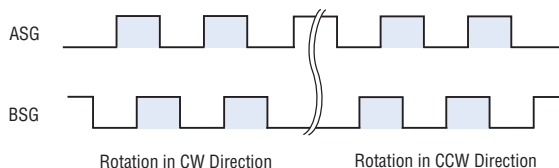

◇ Busy (BUSY) [Torque Limiting (TLM)]/Alarm Pulse (ALARM-PULSE) Output

This output functions as the BUSY output during normal operation, and as the ALARM-PULSE output with a driver protection function is active.

When the torque limiting function is set with a control module, this output can be changed to the TLM output, which indicates that the torque limit has been reached.

● During Normal Operation (Busy output)

Speed control mode: The transistor turns ON during motor operation.

Position control mode: The transistor turns ON during rotation, and turns OFF upon stopping at the set stop position.

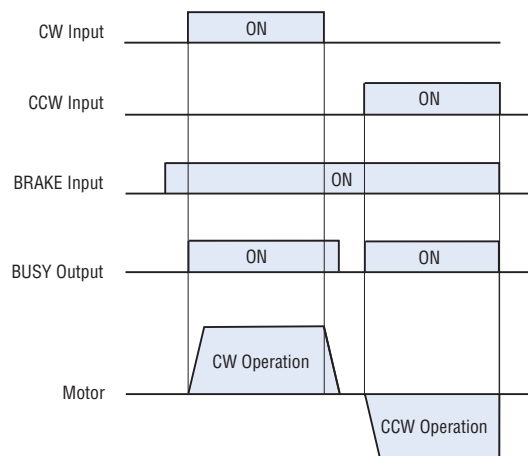

● When a Torque Limiting Value is Set

[This signal can be used as the torque limiting (TLM) output.]

Speed control mode/position control mode: The transistor turns ON when the specified torque limit is reached.

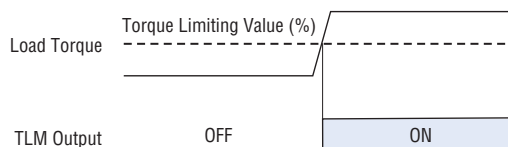

Notes:

- An accessory control module **OPX-1A** is required to implement torque limiting.
 - Switch the busy (BUSY) output to the torque limiting (TLM) output.
 - The maximum error between the torque limiting and actual generated torque is approximately 20% (starting torque: 100%).
- Torque limiting function when using a control module → Page B-56

● Upon Activation of a Protection Function

[(ALARM-PULSE output)]

If a one shot input (0.1 s or more) is given to the rotation direction or START input, a pulse (5 Hz) will be output for the number of times equivalent to the number of times the ALARM LED blinks upon activation of a protective function. It is possible to determine the type of protective function that has been activated by counting the number of pulses from controller.

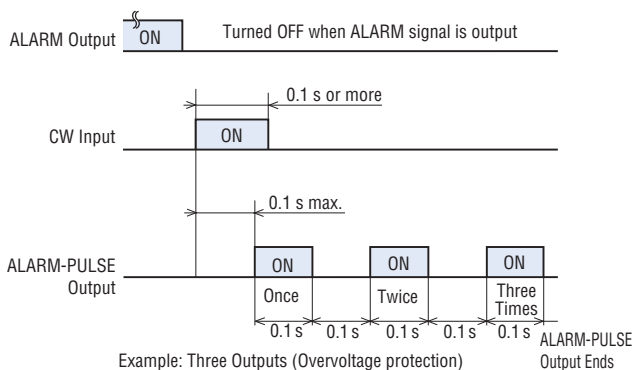

● Output Signals (When using a control module)

- ◇ Alarm (ALARM) Output
- ◇ Phase Difference (ASG/BSG) Output
- ◇ Busy (BUSY) [Torque Limiting (TLM)]/ALARM-PULSE Output same as Output Signals (Standard model)

● Speed Setting Method

(Common to standard model and using a control module)

◇ Using the Internal Speed Potentiometer

Set a desired speed using the potentiometer provided on the driver's front panel. When the internal speed potentiometer is used, set the M0 terminal to "Photocoupler OFF."

◇ Using the External Speed Potentiometer (Included)

When the motor speed is to be set remotely, connect the supplied external speed potentiometer as shown below. When the external speed potentiometer is used, set the M0 terminal to "Photocoupler ON."

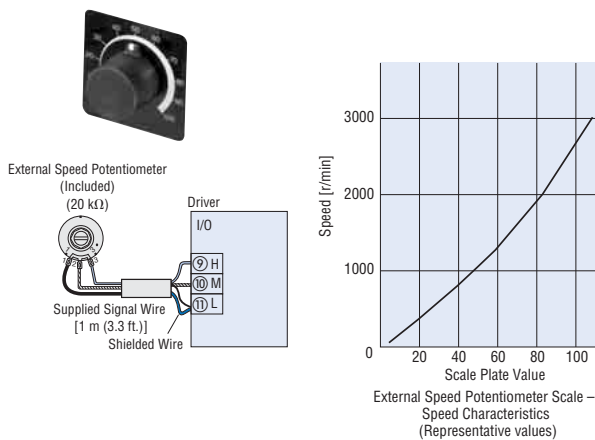

◇ Speed Setting by External DC Voltage

When the motor speed needs to be set using external DC voltage, connect as follows. In this case, set the M0 terminal to "Photocoupler ON."

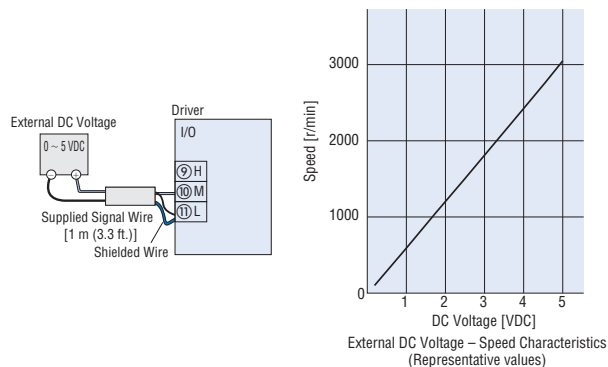

Note:

- When setting speeds using the external speed potentiometer or via external DC voltage, be sure to use the supplied signal line [$\phi 3.3$ mm \times 1 m ($\phi 0.13$ in. \times 3.3 ft.)]. Connect the shielded wire for the signal line to the L terminal. Ensure proper connection on the external speed potentiometer or external DC voltage side so that the shielded wire will not contact with another terminal. The input impedance between the M and L terminals is approximately 15 k Ω .

◇ Digital Setting (Only when a control module is used)

The particular combination of the M0, M1 and M2 inputs selects a maximum of eight sets of speed data. (Common to speed control mode and position control mode)

Speed Control Data	Speed Control Data Selection			Method of Speed Setting
	M0	M1	M2	
No.0	OFF	OFF	OFF	Internal speed potentiometer/ Digital setting
No.1	ON	OFF	OFF	External analog/ Digital setting
No.2	OFF	ON	OFF	Digital setting
No.3	ON	ON	OFF	Digital setting
No.4	OFF	OFF	ON	Digital setting
No.5	ON	OFF	ON	Digital setting
No.6	OFF	ON	ON	Digital setting
No.7	ON	ON	ON	Digital setting

Speed Control

● Multi-Motor Control (Common to standard model and using a control module)

Two or more motors can be operated at the same speed using a single external speed potentiometer or external DC voltage. The figure below shows an example of the single-phase power supply specification. For the three-phase power supply specification, change the power supply line to one for a three-phase power supply. The motor and operation control unit are not illustrated in the figure.

◇ Using an External Speed Potentiometer

Connect all drivers using a common power supply line and common speed control line, as shown in the figure, and set a desired speed using the external speed potentiometer VRx.

The resistance of the external speed potentiometer is determined as follows:

Resistance when the number of drivers is n: $VRx = 20/n$ (k Ω), $n/4$ (W)

Example: When two drivers are connected

$$VRx = 20/2 = 10 \text{ (k}\Omega\text{)}, 2/4 = 1/2 \text{ (W)}$$

Based on the calculation, the resistance should be

10 k Ω , 1/2 W.

To adjust the speed difference among the motors, connect a resistor of 470 Ω , 1/4 W to the M terminal on the first driver, and connect a variable resistor (VRn) of 1 k Ω , 1/4 W to the M terminal on each of the remaining drivers.

The number of motors operated in parallel via the external speed potentiometer should be limited to five or less.

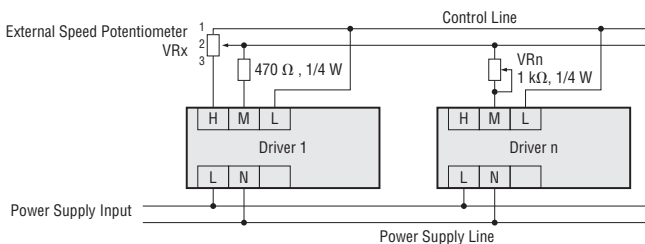

◇ Using External DC Voltage

Connect all drivers using a common power supply line and common speed control line, as shown in the figure, and connect a 5 VDC power supply.

The power supply capacity of the external DC power supply is determined as follows:

Power supply capacity when the number of drivers is n: $I = 1 \times n$ (mA)

Example: When two drivers are connected

$$I = 1 \times 2 = 2 \text{ (mA)}$$

Based on the calculation, the power supply capacity

should be at least 2 mA.

To adjust the speed difference among the motors, connect a resistor of 470 Ω , 1/4 W to the M terminal on the first driver, and connect a variable resistor (VRn) of 1 k Ω , 1/4 W to the M terminal on each of the remaining drivers.

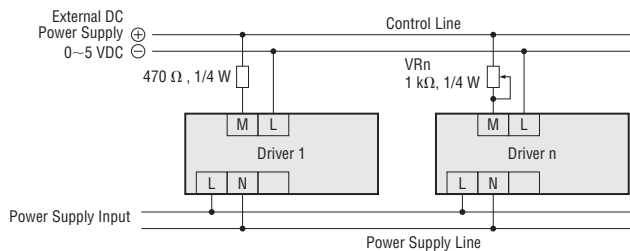

Connection and Operation (Position Control)

When performing a position control motion, an accessory control module **OPX-1A** is required.

Names and Functions of Driver Parts

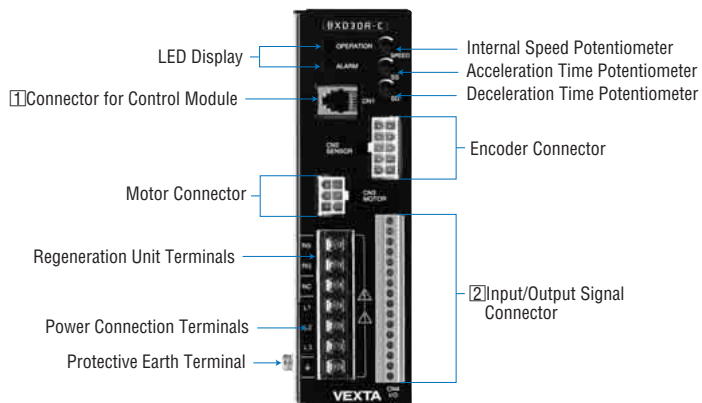

Connector for Control Module

You can extend the position control performance by using an accessory control module **OPX-1A**.

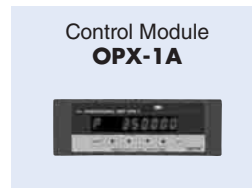

Main Function

Setting Function	<ul style="list-style-type: none"> Travel Amount (6 points max.) Speed (8 speed settings max.) Torque Limiting Values
Displaying Function	<ul style="list-style-type: none"> Positioning Counter (STEP) Speed (r/min) Load Factor (%) Alarm Code Alarm History

● Dimensions → Page B-58

Input/Output Signals

CN4 Terminal Number	I/O	Signal Name	Function
1	Input	START	Starting positioning operation
2		HOME-LS	Mechanical home sensor (normally closed)
3		M0	Positioning data selection
4		M1	
5		M2	
6		FREE	Motor excitation cancellation, electromagnetic brake release
7		BRAKE/ ALARM-RESET	Normal: Brake input Protective function has been activated: Alarm reset input
8	IN-COM	Input signal common	
9	Analog Input	H	Speed setting via the external speed potentiometer or external DC voltage
10		M	
11		L	
12	Output	ALARM	This signal is output when a protective function has been activated (normally closed).
13		BUSY (TLM)*/ ALARM-PULSE	Normal: Busy output Protective function has been activated: Alarm pulse output
14		ASG	500 pulses are output per motor rotation (phase difference output)
15		BSG	
16		OUT-COM	Output signal common

* The BUSY output can be changed to the torque limiting (TLM) output only when a torque limit is set.

Position Control

● Connection Diagram

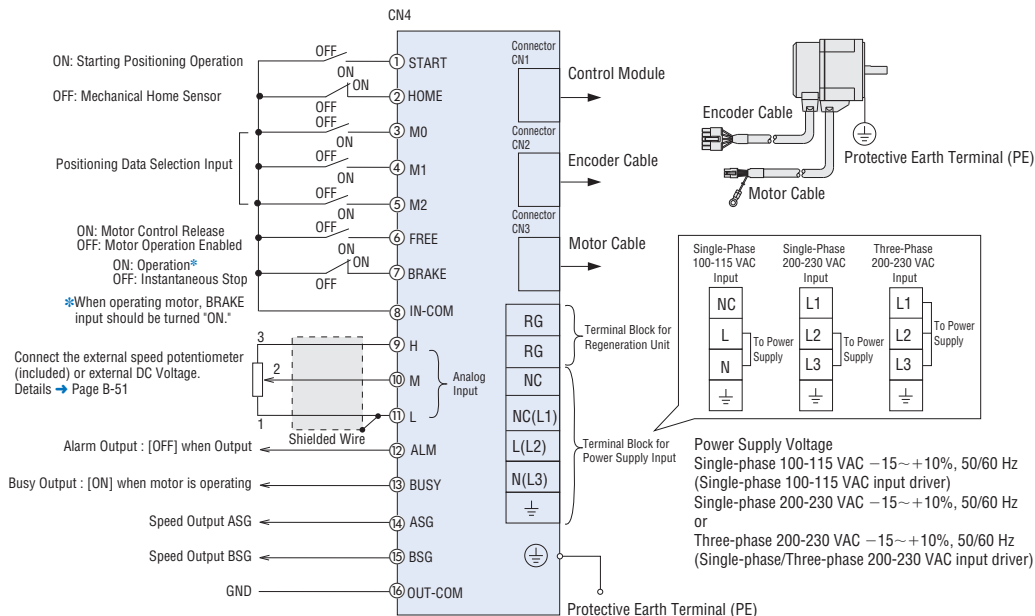

● Refer to the connection diagrams in the speed control mode for applicable crimp terminal and notes on connection. → Page B-47

● Input/Output Signal Circuits

same as Speed Control → Page B-48

● Input Signals

◇ Start (START) Input

This signal starts the positioning, continuous, return to mechanical home or return to electrical home operations. Operation will start when the START input is turned ON after selecting the operation data via the combination of M0, M1 and M2 inputs.

● Positioning Operation

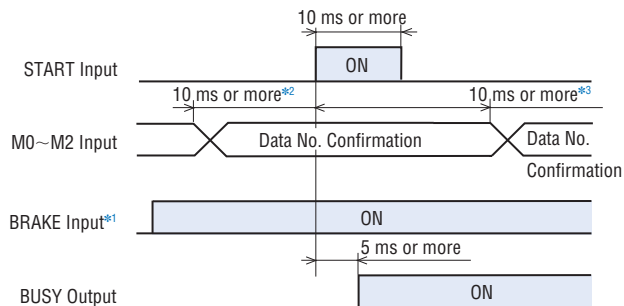

- *1 The motor stops when the BRAKE input is turned OFF. Before starting motor operation, be sure to turn the BRAKE input to ON.
- *2 Input the operation data confirmation signal at least 10 ms before the input of START signal.
- *3 When confirming the data number for the next travel amount following input of the START signal, input the confirmation signal at least 10 ms after the input of that signal.

● When the digital independent torque limiting function is set, the data numbers will be reflected as necessary even during an index operation.

● Continuous Operation

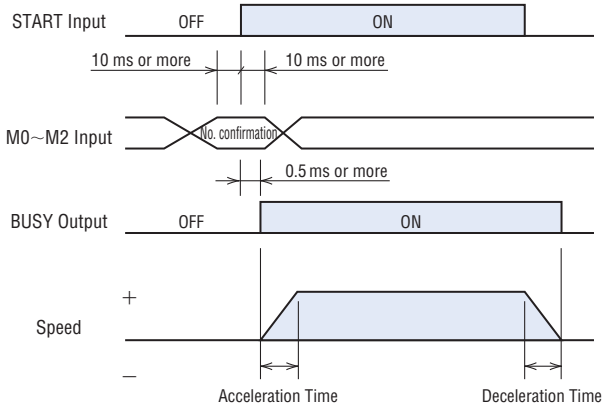

◇ Mechanical Home Sensor (HOME-LS) Input

This signal is used during the return to mechanical home operation.

● Return to Mechanical Home Operation

The mechanical home sensor (HOME-LS input) installed on the equipment is detected with the motor operated in the set detection starting direction. Upon detection of the home sensor, the motor reverses its direction and stops at a position just outside the range of the home sensor.

Mechanical home detection method: 1-sensor mode
(normally closed input)

Starting direction of home detection: Can be set as CW or CCW
(in uni-direction)

Speed input in data: No. 7

No acceleration/deceleration time is set.

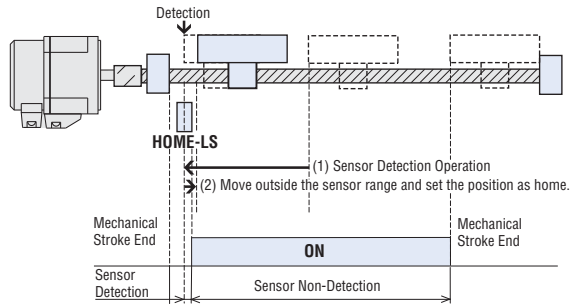

Note:

- Install the home sensor (HOME-LS) before the stroke-end sensor on the detection starting side.

◇ Operation Data Selection (M0, M1, M2) Input

The particular combination of the M0, M1 and M2 inputs selects a maximum of six sets of positioning data as well as the return to home operation.

Operation Data	Operation Data Selection			Position Control Mode	Method of Speed Setting
	M0	M1	M2		
No.0	OFF	OFF	OFF	Positioning operation 0/ Continuous operation 0	Internal speed potentiometer/ Digital setting
No.1	ON	OFF	OFF	Positioning operation 1/ Continuous operation 1	External analog/ Digital setting
No.2	OFF	ON	OFF	Positioning operation 2	Digital setting
No.3	ON	ON	OFF	Positioning operation 3	Digital setting
No.4	OFF	OFF	ON	Positioning operation 4	Digital setting
No.5	ON	OFF	ON	Positioning operation 5	Digital setting
No.6	OFF	ON	ON	Return to electrical home operation	Digital setting
No.7	ON	ON	ON	Return to mechanical home operation	Digital setting

- Speed can be set for each data.
Speed data is set in the same manner as in the speed control mode.
- No. 0 and No. 1 allow the switching of positioning operation and continuous operation.

◇ Motor Control Release (FREE) Input

same as Input Signals (Standard model) → Page B-49

◇ Brake (BRAKE)/Alarm Reset (ALARM-RESET) Input

same as Input Signals (Standard model) → Page B-49

● Output Signals

◇ Alarm (ALARM) Output

◇ Phase Difference (ASG/BSG) Output

◇ Busy (BUSY) [Torque Limiting (TLM)]/Alarm Pulse (ALARM-PULSE) Output

same as Output Signals (Standard model) → Page B-50

Torque Limiting

Torque Limiting Function When Using a Control Module

The **BX** Series permits the setting of a motor output torque limit in both the speed control mode of extended system and position control mode. The torque limit is set relative to the starting torque being 100%. When torque needs to be limited continuously during push-motion operation or winding operation, set the limit to rated torque or less.

Calculate the output torque for the combination type based on the applicable speed and torque, using the "Speed-Torque Limit Characteristics" graphs and formulas shown below.

Gearhead output shaft speed $N_G = \text{Motor shaft speed} \times 1/\text{Gearhead ratio}$

Gearhead output shaft torque $T_G = \text{Motor torque} \times \text{Gearhead ratio} \times 0.9$ (coefficient)

Speed - Torque Limit Characteristics (Reference values)

BX230 -A/**BX230** -S/**BX230** -FR
BX230 M-A/**BX230** M-S/**BX230** M-FR

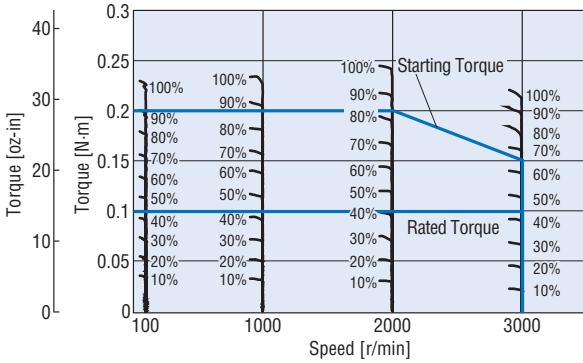

BX460 -A/**BX460** -S/**BX460** -FR
BX460 M-A/**BX460** M-S/**BX460** M-FR

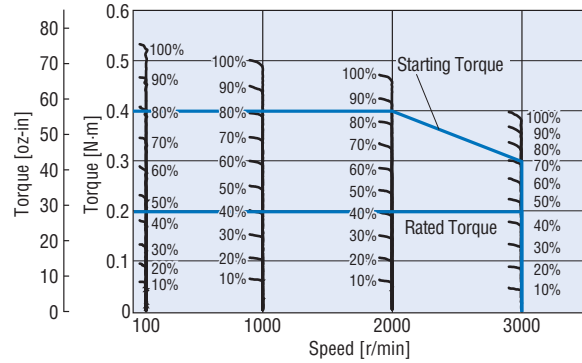

BX5120 -A/**BX5120** -S/**BX5120** -FR
BX5120 M-A/**BX5120** M-S/**BX5120** M-FR

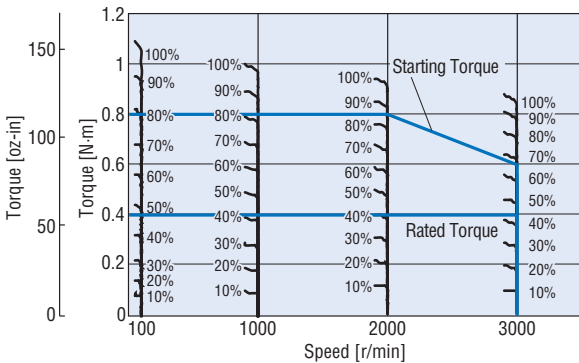

BX6200 -A/**BX6200** -S/**BX6200** -FR
BX6200 M-A/**BX6200** M-S/**BX6200** M-FR

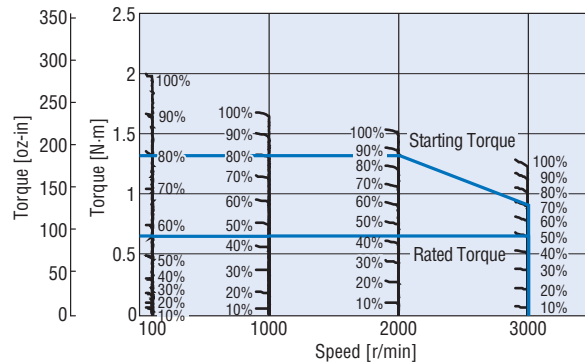

BX6400S-A/**BX6400S** S
BX6400SM-A/**BX6400SM** S

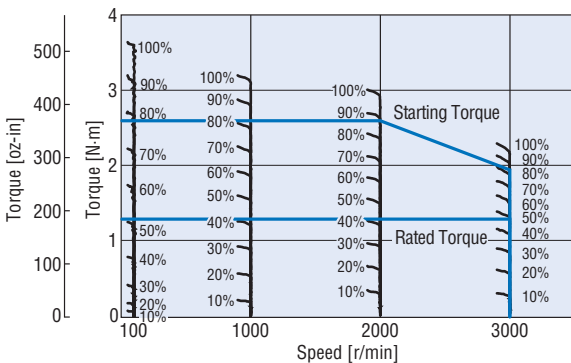

Note:

- An error of up to approximately $\pm 20\%$ (starting torque: 100%) may occur between the set value and generated torque due to the speed setting, power supply voltage and distance of motor cable extension. Repetitive accuracy under the same condition is approximately $\pm 10\%$.

- Enter the power supply voltage (**A** or **C**) in the box () within the model name. Enter the gear ratio in the box () within the model name.