



## New 5-Phase Stepping Motor and Driver Package

# RK II Series Pulse input type

## USER MANUAL



Thank you for purchasing an Oriental Motor product.

This Operating Manual describes product handling procedures and safety precautions.

- Please read it thoroughly to ensure safe operation.
- Always keep the manual where it is readily available.

### Table of contents

1	Introduction .....	2	11	Guidance .....	30
2	Overview of the product .....	3	11.1	Standard type .....	30
3	System configuration .....	4	11.2	Standard type with electromagnetic brake .....	31
4	Safety precautions .....	5	12	Explanation of I/O signals .....	32
5	Precautions for use .....	8	12.1	Input signals .....	32
6	General specifications .....	10	12.2	Output signals .....	34
7	CE Marking .....	11	12.3	Timing charts .....	35
8	Preparation .....	12	13	Setting .....	37
8.1	Checking the product .....	12	13.1	Pulse input mode .....	37
8.2	Combinations of motors and drivers .....	12	13.2	Step angle .....	37
8.3	Names and functions of parts .....	14	13.3	Operating current .....	38
9	Installation .....	16	13.4	Standstill current .....	38
9.1	Location for installation .....	16	14	Alarms .....	39
9.2	Installing the motor .....	16	15	Inspection .....	40
9.3	Installing a load .....	17	16	Troubleshooting and remedial actions .....	41
9.4	Permissible radial load and permissible axial load .....	18	17	Accessories (sold separately) .....	43
9.5	Installing the driver .....	19			
10	Connection .....	20			
10.1	Connection example .....	20			
10.2	Grounding the motor and driver .....	26			
10.3	Noise measures .....	27			
10.4	Conformity to the EMC Directive .....	28			

# 1 Introduction

---

## ■ Before use

Only qualified personnel should work with the product.

Use the product correctly after thoroughly reading the section “4 Safety precautions” on p.5.

The product described in this manual has been designed and manufactured for use in general industrial equipment.

Do not use for any other purpose. Oriental Motor Co., Ltd. is not responsible for any damage caused through failure to observe this warning.

## ■ Operating Manuals for the RK II Series

Operating manuals for the **RK II** Series Pulse input type are listed below.

After reading these manuals, keep them in a convenient place so that you can reference them at any time.

Type of operating manual	Model	Description of operating manual
Instructions and Precautions for Safe Use Motor	HM-60087	This manual explains precautions to use the motor, as well as the motor installation and others.
Driver OPERATING MANUAL	HM-60233	This manual explains the installation method as well as the connection method and others for the driver.
USER MANUAL	HM-60234	This manual explains the functions, installation/connection method and data setting method as well as the operating method and others for the motor and driver.

## ■ Hazardous substances

The products do not contain the substances exceeding the restriction values of RoHS Directive (2011/65/EU).

## 2 Overview of the product

---

The **RK II** Series is a motor and driver package product consisting of a high-efficiency, 5-phase stepping motor and high-performance microstep driver. This is a standard model for 5-phase stepping motor and driver package product.

### ■ Main features

- **Energy-saving**

Motor and driver losses have been substantially reduced to achieve low heat generation and save energy. Since the motor and driver generate much less heat, they can now be operated for longer hours at high speed, which was not possible with conventional motors/drivers.

- **Closely installable compact, slim size driver**

This compact size driver helps downsizing and space-saving for the control box and equipment. Since the drivers are available to install closely, the limited space can effectively be utilized.

- **Simple wiring**

Screwless type connectors have adopted for connection of I/O signals. The motor can be connected with ease using the dedicated cable/connector assembly.

- **Low vibration**

Adopting a high performance microstep driver, this product achieved a smooth drive operation with ultra low-vibration, even if the operation was at low speeds.

- **Various resolution**

The resolution can be selected from 32 types that are in the range of 200 PPR to 200,000 PPR. Also, the same resolution as 2-phase stepping motor can be set.

- **Automatic control of the electromagnetic brake (electromagnetic brake type only)**

This driver controls the electromagnetic brake automatically. The control signal input or the troublesome ladder logic design can be saved.

- **Alarm function**

The driver provides alarms that are designed to protect the driver from overheating, poor connection, error in operation, etc. (protective functions).

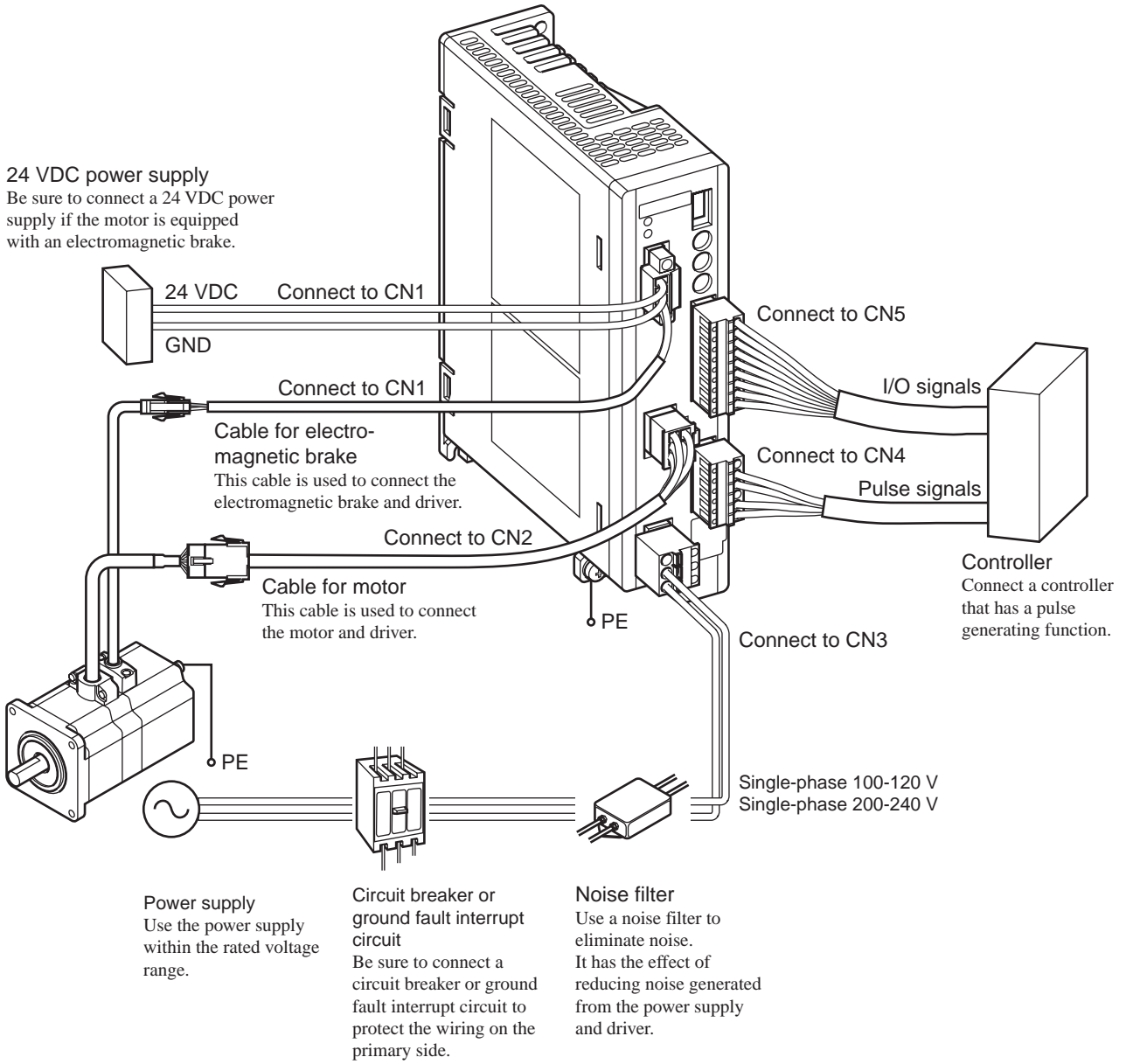

# 3 System configuration





# 4 Safety precautions





The precautions described below are intended to prevent danger or injury to the user and other personnel through safe, correct use of the product. Use the product only after carefully reading and fully understanding these instructions.

## Description of signs





 <b>Warning</b>	Handling the product without observing the instructions that accompany a "Warning" symbol may result in serious injury or death.
 <b>Caution</b>	Handling the product without observing the instructions that accompany a "Caution" symbol may result in injury or property damage.

## Description of graphic symbols

	Indicates "prohibited" actions that must not be performed.		Indicates "compulsory" actions that must be performed.
---	--	---	--





 <b>Warning</b>	
	Do not use the product in explosive or corrosive environments, in the presence of flammable gases, locations subjected to splashing water, or near combustibles. This may cause fire, electric shock or injury.
	Do not transport, install the product, perform connections or inspections when the power is on. This may cause electric shock.
	Do not touch the driver while the power is on This may cause fire or electric shock.
	The terminals on the driver's front panel marked with   symbol indicate the presence of high voltage. Do not touch these terminals while the power is on. This may cause fire or electric shock.
	Do not use the brake mechanism of an electromagnetic brake motor as a deceleration/safety brake. This may cause injury or damage to the equipment.
	Do not forcibly bend, pull or pinch the cable. This may cause fire or electric shock.
	Do not turn the AWO input or FREE input to ON while the motor is operating. This may cause injury or damage to equipment.
	Do not touch the connection terminals on the driver immediately (within 10 minute) after the power is turned off. This may cause electric shock.
Do not disassemble or modify the product. This may cause injury or damage to equipment.	
	Assign qualified personnel the task of installing, wiring, operating/controlling, inspecting and troubleshooting the product. Failure to do so may result in fire, electric shock, injury or damage to equipment.
	If this product is used in an vertical application, be sure to provide a measure for the position retention of moving parts. Failure to do so may result in injury or damage to equipment.
	When the driver generates an alarm (any of the driver's protective functions is triggered), take measures to hold the moving part in place since the motor stops and loses its holding torque. Failure to do so may result in injury or damage to equipment.
	When the driver generates an alarm (any of the driver's protective functions is triggered), first remove the cause and then clear the protection function. Continuing the operation without removing the cause of the problem may cause malfunction of the motor and driver, leading to injury or damage to equipment.
	Install the product in an enclosure. Failure to do so may result in electric shock or injury.
	The motor and driver are designed with Class I equipment basic insulation. When installing the motor and driver, do not touch the product or be sure to ground them. Failure to do so may result in electric shock.
	Keep the driver's input-power voltage within the specified range. Failure to do so may result in fire or electric shock.
Connect the cables securely according to the wiring diagram. Failure to do so may result in fire or electric shock.	

	Turn off the driver power in the event of a power failure. Failure to do so may result in injury or damage to equipment.
---	---

 <b>Caution</b>	
	Do not use the product beyond its specifications. This may cause injury, electric shock or damage to equipment.
	Keep your fingers and objects out of the openings in the product. Failure to do so may result in fire, electric shock or injury.
	Do not touch the product during operation or immediately after stopping. This may cause a skin burn(s).
	Do not forcibly bend or pull the cable that was connected to the driver. Doing so may cause damage.
	Do not hold the motor output shaft or motor cable. This may cause injury.
	Keep the area around the product free of combustible materials. Failure to do so may result in fire or a skin burn(s).
	Leave nothing around the product that would obstruct ventilation. Failure to do so may result in damage to equipment.
	Do not touch the rotating parts (output shaft etc.) during operation. This may cause injury.
	Do not touch the terminals while performing the insulation resistance test or dielectric strength test. This may cause electric shock.
	Provide a cover over the rotating parts (output shaft etc.). Failure to do so may result in injury.
	Use a motor and driver only in the specified combination. Failure to do so may result in fire.
	For the 24 VDC power supply, use a DC power supply with reinforced insulation on its primary and secondary sides. Failure to do so may result in electric shock.
	Provide an emergency stop device or emergency stop circuit external to the equipment so that the entire equipment will operate safely in the event of a system failure or malfunction. Failure to do so may result in injury.
	Before supplying power to the driver, turn all input signals to the driver to OFF. Failure to do so may result in injury or damage to equipment.
	Before moving the motor directly with the hands, confirm that the AWO input or FREE input turns ON. Failure to do so may result in injury.
	When an abnormal condition has occurred, immediately stop operation and turn off the driver power. Failure to do so may result in fire, electric shock or injury.
	Use only an insulated screwdriver to adjust the driver's switches. Failure to do so may result in electric shock.
	To dispose of the motor and driver, disassemble it into parts and components as much as possible and dispose of individual parts/components as industrial waste.
The motor surface temperature may exceed 70 °C (158 °F) even under normal operating conditions. If the operator is allowed to approach the running motor, attach a warning label as shown below in a conspicuous position. Failure to do so may result in skin burn(s).	 Warning label

## ■ Warning information

A warning label with handling instructions is attached on the driver. Be sure to observe the instructions on the label when handling the driver.

	<b>WARNING – Risk of electric shock.</b>
	<ul style="list-style-type: none"> <li>• Read manual before installing.</li> <li>• Do not touch the driver for 10 minutes after the power is turned off. Residual voltage may cause electric shock.</li> </ul>
	<b>AVERTISSEMENT – Risque de décharge électrique.</b>
	<ul style="list-style-type: none"> <li>• Lire le manuel avant l'installation.</li> <li>• Ne touchez pas les variateur les 10 minutes qui suivent la mise hors tension. La tension résiduelle peut entraîner un choc électrique.</li> </ul>
	<b>警告</b> けが・感電のおそれがあります。
	<ul style="list-style-type: none"> <li>• 据え付け、運転の前には必ず取扱説明書をお読みください。</li> <li>• 電源を切った直後、10分間ドライバに触れないでください。残留電圧により感電の原因になります。</li> </ul>

Material: PET

# 5 Precautions for use

---

This section covers limitations and requirements the user should consider when using the product.

- **Always use the cable (supplied or accessory) to connect the motor and driver.**

Be sure to use the cable (supplied or accessory) to connect the motor and driver.

If a cable other than the supplied cable or accessory cable (sold separately) is used, the driver may generate a large amount of heat.

In the following condition, an appropriate accessory cable must be purchased separately. Refer to p.43 for details.

- If a flexible cable is to be used.
- If a cable of 3 m (9.8 ft.) or longer is to be used.
- If a motor and driver package without a cable was purchased.

- **Perform the insulation resistance test or dielectric strength test separately on the motor and the driver.**

Performing the insulation resistance test or dielectric strength test with the motor and driver connected may result in damage to the product.

- **Do not apply a radial load and axial load in excess of the specified permissible limit**

Operating the motor under an excessive radial load or axial load may damage the motor bearings (ball bearings). Be sure to operate the motor within the specified permissible limit of radial load and axial load. Refer to p.18 for details.

- **Motor case temperature**

The driver has an overheat protection function, but the motor has no such feature. The motor surface temperature may exceed 100 °C (212 °F) under certain conditions (ambient temperature, operating speed, duty cycle, etc.). To prevent the motor bearings (ball bearings) from reaching its usable life quickly, use the motor in conditions where the surface temperature will not exceed 100 °C (212 °F).

Use the geared type motor in a condition where the gear case temperature does not exceed 70 °C (158 °F), in order to prevent deterioration of grease and parts in the gear case.

- **Holding torque at standstill**

The motor holding torque is reduced by the current cutback function of the driver at motor standstill. When selecting a motor for your application, consider the fact that the holding torque will be reduced at motor standstill.

- **Do not use the electromagnetic brake to reduce speed or as a safety brake.**

Do not use the electromagnetic brake as a means to decelerate and stop the motor. The brake hub of the electromagnetic brake will wear significantly and the braking force will drop if used to stop the motor.

The electromagnetic brake is a power-off activated type. This means that although it helps maintain the position of the load in the event of power outage, etc., this brake cannot securely hold the load in place. Accordingly, do not use the electromagnetic brake as a safety brake. To use the electromagnetic brake to hold the load in place, do so after the motor has stopped.

- **Preventing leakage current**

Stray capacitance exists between the driver's current-carrying line and other current-carrying lines, the earth and the motor, respectively. A high-frequency current may leak out through such capacitance, having a detrimental effect on the surrounding equipment. The actual leakage current depends on the driver's switching frequency, the length of wiring between the driver and motor, and so on.

When connecting an earth leakage breaker, use one of the following products offering resistance against high frequency current:

Mitsubishi Electric Corporation: NV series

Fuji Electric FA Components & Systems Co., Ltd.: EG and SG series

- **Preventing electrical noise**

See "10.3 Noise measures" on p.27 for measures with regard to noise.

- **Grease of geared type motor**

On rare occasions, a small amount of grease may ooze out from the geared type motor. If there is concern over possible environmental damage resulting from the leakage of grease, check for grease stains during regular inspections. Alternatively, install an oil pan or other device to prevent leakage from causing further damage. Oil leakage may lead to problems in the customer's equipment or products.



- **Rotation direction of the gear output shaft**

The relationship between the rotation direction of the motor shaft and that of the gear output shaft changes as follows, depending on the gear type and gear ratio.

Type of gear	Gear ratio	Rotation direction (relative to the motor rotation direction)
<b>TS</b> geared	3.6, 7.2, 10	Same direction
	20, 30	Opposite direction
<b>PS</b> geared	All gear ratios	Same direction
Harmonic geared	All gear ratios	Opposite direction

- **Maximum torque of geared type motor**

Always operate the geared type motor under a load not exceeding the maximum torque. If the load exceeds the maximum torque, the gear will be damaged.

# 6 General specifications

		Motor	Driver
Degree of protection		IP20	IP20
Operation environment	Ambient temperature	-10 to +50 °C (+14 to +122 °F) (non-freezing) Harmonic geared type: 0 to +40 °C (+32 to +104 °F) (non-freezing)	0 to +55 °C (+32 to 131 °F) * (non-freezing)
	Humidity	85% or less (non-condensing)	
	Altitude	Up to 1000 m (3300 ft.) above sea level	
	Surrounding atmosphere	No corrosive gas, dust, water or oil	
Storage environment	Ambient temperature	-20 to +60 °C (-4 to +140 °F) (non-freezing)	-25 to +70 °C (-13 to +158 °F) (non-freezing)
	Humidity	85% or less (non-condensing)	
	Altitude	Up to 3000 m (10000 ft.) above sea level	
	Surrounding atmosphere	No corrosive gas, dust, water or oil	
Shipping environment	Ambient temperature	-20 to +60 °C (-4 to +140 °F) (non-freezing)	-25 to +70 °C (-13 to +158 °F) (non-freezing)
	Humidity	85% or less (non-condensing)	
	Altitude	Up to 3000 m (10000 ft.) above sea level	
	Surrounding atmosphere	No corrosive gas, dust, water or oil	
Insulation resistance	100 MΩ or more when 500 VDC megger is applied between the following places: • Case - Motor windings • Case - Electromagnetic brake windings	100 MΩ or more when 500 VDC megger is applied between the following places: • PE terminal - Power supply terminals • Signal I/O terminals - Power supply terminals	
Dielectric strength	Sufficient to withstand the following for 1 minute: • Case - Motor windings 1.5 kVAC 50/60 Hz • Case - Electromagnetic brake windings 1.5 kVAC 50/60 Hz	Sufficient to withstand the following for 1 minute: • PE terminal - Power supply terminals 1.8 kVAC 50/60 Hz • Signal I/O terminals - Power supply terminals 1.9 kVAC 50/60 Hz	

\* When installing a driver on a heat sink. [material: aluminium, 200×200×2 mm (7.87×7.87×0.08 in.) equivalent]

# 7 CE Marking

This product is affixed the CE Marking under the Low Voltage Directive and EMC Directive.

## ■ Low Voltage Directives

- The product is a type with machinery incorporated, so it should be installed within an enclosure.
- This product cannot be used with cables normally used for IT equipment.
- Install the product within the enclosure in order to avoid contact with hands.
- Be sure to maintain a protective ground in case hands should make contact with the product. Be sure to connect the Protective Earth lead of the cable for motor to the Protective Earth Terminal on the driver, and ground the driver's Protective Earth Terminal.
- To protect against electric shock using an earth leakage breaker (RCD), connect a type B earth leakage breaker to the primary side of the driver.
- When using a circuit breaker (MCCB), use a unit conforming to the EN or IEC standard.
- Isolate the motor cable, power-supply cable and other drive cables from the signal cables (CN1, CN4 and CN5) by means of double insulation.
- The temperature of the driver's heat sink may exceed 90 °C (194 °F) depending on the driving conditions. Accordingly, take heed of the following items:
  - Do not touch the driver.
  - Do not use the driver near flammable objects.
  - Always conduct a trial operation to check the driver temperature.

### • Applicable Standards

Motor: EN 60034-1, EN 60034-5, EN 60664-1

Driver: EN 61800-5-1

### • Installation conditions (EN Standard)

Motor	Driver
Motor is to be used as a component within other equipment. Overvoltage category: II Pollution degree: 2 Degree of protection: IP20 Protection against electric shock: Class I	Driver is to be used as a component within other equipment. Overvoltage category: II Pollution degree: 2 Degree of protection: IP20 Protection against electric shock: Class I

## ■ EMC Directive

This product has received EMC compliance under the conditions specified in “Example of motor and driver installation and wiring” on p.29. Since the compliance of the final machinery with the EMC Directive will depend on such factors as the configuration, wiring, layout and risk involved in the control-system equipment and electrical parts, it therefore must be verified through EMC measures by the customer of the machinery.

### Applicable Standards

EMI	EN 55011 Group1 Class A
	EN 61000-6-4
	EN 61800-3
	EN 61000-3-2 EN 61000-3-3
EMS	EN 61000-6-2
	EN 61800-3

This type of PDS is not intended to be used on a low-voltage public network which supplies domestic premises; radio frequency interference is expected if used on such a network.

# 8 Preparation

This chapter explains the items you should check, as well as the name and function of each part.

## 8.1 Checking the product

Verify that the items listed below are included. Report any missing or damaged items to the branch or sales office from which you purchased the product.

Model names for motor and driver combinations are shown in the “8.2 Combinations of motors and drivers.”

- Motor ..... 1 unit
- Driver..... 1 unit
- Cable for motor..... 1 pc.  
(When the product is supplied with a connection cable)
- Cable for electromagnetic brake ..... 1 pc.  
(When the product is a motor with an electromagnetic brake supplied with a connection cable)
- CN1 connector (4 pins)..... 1 pc.  
(When the product is a motor with an electromagnetic brake)
- CN3 connector (3 pins)..... 1 pc.
- CN4 connector (6 pins)..... 1 pc.
- CN5 connector (9 pins)..... 1 pc.
- Parallel key ..... 1 pc.  
(Supplied with geared types; except for the **RKS543-TS**)
- Motor mounting screw (M4)..... 4 pcs. (Supplied with **RKS564-TS**)
- Motor mounting screw (M8)..... 4 pcs. (Supplied with **RKS596-TS**)
- Instructions and Precautions for Safe Use Motor..... 1 copy
- Driver OPERATING MANUAL..... 1 copy
- USER MANUAL (CD-ROM) ..... 1 pc.

## 8.2 Combinations of motors and drivers

- □ indicates **A** (single shaft) or **B** (double shaft).
- ■ indicates **A** (single-phase 100-120 V) or **C** (single-phase 200-240 V).
- ● represents a number indicating the gear ratio.
- ○ indicates the supplied cable length.

### ■ Standard type

Model		Motor model	Driver model
With supplied cable	Without supplied cable		
RKS543□■-○	RKS543□■	PKE543□C	RKSD503-■
RKS544□■-○	RKS544□■	PKE544□C	
RKS545□■-○	RKS545□■	PKE545□C	
RKS564□■-○	RKS564□■	PKE564□C	RKSD507-■
RKS566□■-○	RKS566□■	PKE566□C	
RKS569□■-○	RKS569□■	PKE569□C	
RKS596□■-○	RKS596□■	PKE596□C	
RKS599□■-○	RKS599□■	PKE599□C	
RKS5913□■-○	RKS5913□■	PKE5913□C	

### ■ Standard type with electromagnetic brake

Model		Motor model	Driver model
With supplied cable	Without supplied cable		
RKS543M■-○	RKS543M■	PKE543MC	RKSD503M-■
RKS544M■-○	RKS544M■	PKE544MC	
RKS545M■-○	RKS545M■	PKE545MC	
RKS564M■-○	RKS564M■	PKE564MC	RKSD507M-■
RKS566M■-○	RKS566M■	PKE566MC	
RKS569M■-○	RKS569M■	PKE569MC	
RKS596M■-○	RKS596M■	PKE596MC	
RKS599M■-○	RKS599M■	PKE599MC	
RKS5913M■-○	RKS5913M■	PKE5913MC	

### ■ TS geared type

Model		Motor model	Driver model
With supplied cable	Without supplied cable		
RKS543□■-TS●-○	RKS543□■-TS●	PKE543□C-TS●	RKSD503-■
RKS564□■-TS●-○	RKS564□■-TS●	PKE564□C-TS●	RKSD507-■
RKS596□■-TS●-○	RKS596□■-TS●	PKE596□C-TS●	

### ■ TS geared type with electromagnetic brake

Model		Motor model	Driver model
With supplied cable	Without supplied cable		
RKS543M■-TS●-○	RKS543M■-TS●	PKE543MC-TS●	RKSD503M-■
RKS564M■-TS●-○	RKS564M■-TS●	PKE564MC-TS●	RKSD507M-■
RKS596M■-TS●-○	RKS596M■-TS●	PKE596MC-TS●	

### ■ PS geared type

Model		Motor model	Driver model
With supplied cable	Without supplied cable		
RKS543□■-PS●-○	RKS543□■-PS●	PKE543□C-PS●	RKSD503-■
RKS545□■-PS●-○	RKS545□■-PS●	PKE545□C-PS●	
RKS564□■-PS●-○	RKS564□■-PS●	PKE564□C-PS●	RKSD507-■
RKS566□■-PS●-○	RKS566□■-PS●	PKE566□C-PS●	
RKS596□■-PS●-○	RKS596□■-PS●	PKE596□C-PS●	
RKS599□■-PS●-○	RKS599□■-PS●	PKE599□C-PS●	

### ■ PS geared type with electromagnetic brake

Model		Motor model	Driver model
With supplied cable	Without supplied cable		
RKS543M■-PS●-○	RKS543M■-PS●	PKE543MC-PS●	RKSD503M-■
RKS545M■-PS●-○	RKS545M■-PS●	PKE545MC-PS●	
RKS564M■-PS●-○	RKS564M■-PS●	PKE564MC-PS●	RKSD507M-■
RKS566M■-PS●-○	RKS566M■-PS●	PKE566MC-PS●	
RKS596M■-PS●-○	RKS596M■-PS●	PKE596MC-PS●	
RKS599M■-PS●-○	RKS599M■-PS●	PKE599MC-PS●	

### ■ Harmonic geared type

Model		Motor model	Driver model
With supplied cable	Without supplied cable		
RKS543□■-HS●-○	RKS543□■-HS●	PKE543□C-HS●	RKSD503-■
RKS564□■-HS●-○	RKS564□■-HS●	PKE564□C-HS●	RKSD507-■
RKS596□■-HS●-○	RKS596□■-HS●	PKE596□C-HS●	

### ■ Harmonic geared type with electromagnetic brake

Model		Motor model	Driver model
With supplied cable	Without supplied cable		
RKS543M■-HS●-○	RKS543M■-HS●	PKE543MC-HS●	RKSD503M-■
RKS564M■-HS●-○	RKS564M■-HS●	PKE564MC-HS●	RKSD507M-■
RKS596M■-HS●-○	RKS596M■-HS●	PKE596MC-HS●	

### 8.3 Names and functions of parts

#### ■ Driver front side

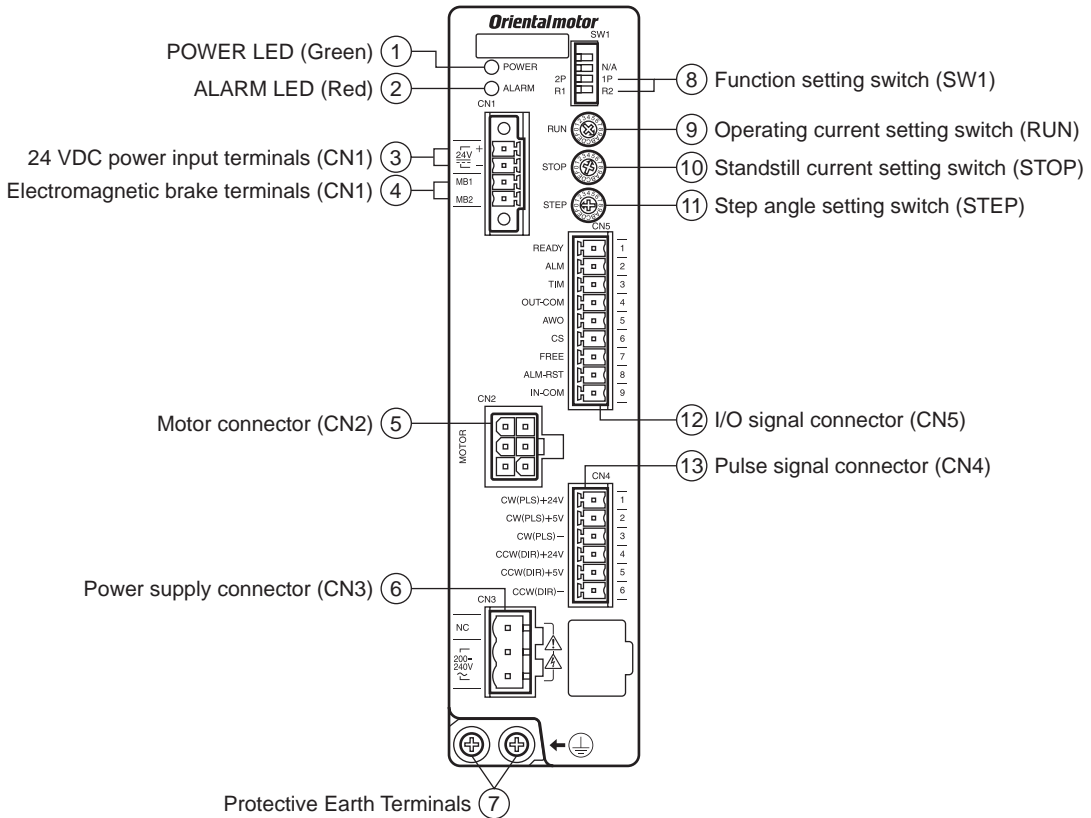

No.	Name	Description	Ref
1	POWER LED (Green)	This LED is lit while the power is input.	-
2	ALARM LED (Red)	This LED will blink when an alarm generates. It is possible to check the generated alarm by counting the number of times the LED blinks.	P.39
3	24 VDC power input terminals (CN1: 24V+, 24V-)	Connects the 24 VDC power supply for electromagnetic brake. (electromagnetic brake motor only)	P.20
4	Electromagnetic brake terminals (CN1: MB1, MB2)	Connects the lead wires of the "cable for electromagnetic brake." (electromagnetic brake motor only) MB1: Electromagnetic brake - (black) MB2: Electromagnetic brake + (white)	
5	Motor connector (CN2)	Connects the motor using the "cable for motor."	
6	Power supply connector (CN3)	Connects the main power supply.	
7	Protective Earth Terminals	Used for grounding via a grounding cable of AWG16 to 14 (1.25 to 2.0 mm <sup>2</sup> ).	P.25
8	Function setting switch (SW1)	<p>Do not change the setting for No.4. The motor will not operate properly.</p> <p>• 2P/1P: This switch is used to set the pulse input mode. • R1/R2: This switch is used to set the motor step angle in combination with the step angle setting switch (STEP).</p>	P.37
9	Operating current setting switch (RUN)	This switch is used to set the motor operating current.	P.38
10	Standstill current setting switch (STOP)	This switch is used to set the motor standstill current.	

No.	Name	Description	Ref
11	Step angle setting switch (STEP)	This switch is used to set the motor step angle in combination with the function setting switch (SW1).	P.37
12	I/O signal connector (CN5)	Connects the input/output signals.	P.20
13	Pulse signal connector (CN4)	Connects the pulse signals.	

## ■ Driver rear side

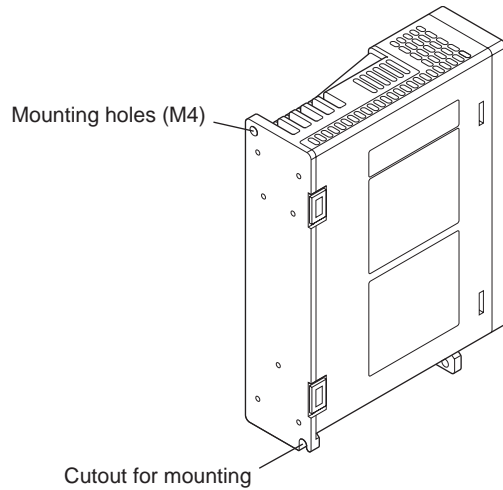

## ■ Motor (electromagnetic brake motor)

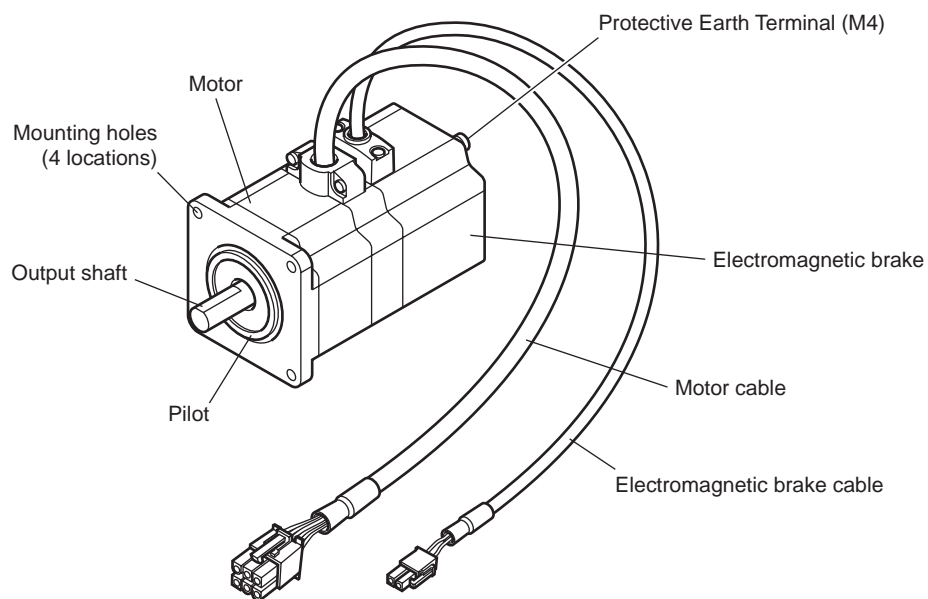

# 9 Installation

This chapter explains the installation location and installation methods of the motor and driver, along with load installation.

## 9.1 Location for installation

The motor and driver has been designed and manufactured to be installed within another device. Install them in a well-ventilated location that provides easy access for inspection.

The location must also satisfy the following conditions:

- Inside an enclosure that is installed indoors (provide vent holes)
- Operating ambient temperature
  - Motor:  $-10$  to  $+50$  °C ( $+14$  to  $+122$  °F) (non-freezing)
  - Harmonic geared type:  $0$  to  $+40$  °C ( $+32$  to  $+104$  °F) (non-freezing)
  - Driver:  $0$  to  $+55$  °C ( $+32$  to  $+131$  °F) (non-freezing)
- Operating ambient humidity 85% or less (non-condensing)
- Area that is free of explosive atmosphere or toxic gas (such as sulfuric gas) or liquid
- Area not exposed to direct sun
- Area free of excessive amount of dust, iron particles or the like
- Area not subject to splashing water (rain, water droplets), oil (oil droplets) or other liquids
- Area free of excessive salt
- Area not subject to continuous vibration or excessive shocks
- Area free of excessive electromagnetic noise (from welders, power machinery, etc.)
- Area free of radioactive materials, magnetic fields or vacuum
- 1000 m (3300 ft.) or lower above sea level

## 9.2 Installing the motor

The motor can be installed in any direction.

To allow for heat dissipation and prevent vibration, install the motor on a metal surface of sufficient strength.

For **RKS564-TS** and **RKS596-TS**, Install the motor using the supplied screws.

### • Installation method A

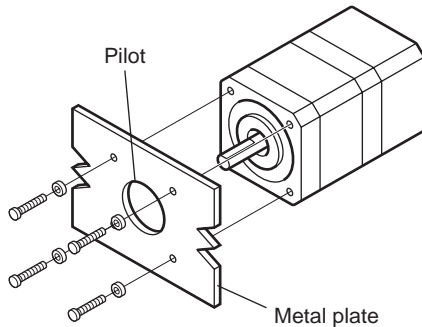

### • Installation method B

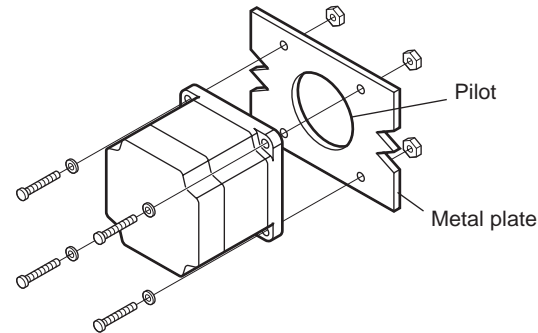

### Nominal size, tightening torque and installation method

Type	Model	Nominal size	Tightening torque [N·m (oz-in)]	Effective depth of bolt [mm (in.)]	Installation method
Standard	<b>RKS54</b>	M3	1 (142)	4.5 (0.177)	A
	<b>RKS56</b>	M4	2 (280)	-	B
	<b>RKS59</b>	M6	3 (420)		
TS geared	<b>RKS54</b>	M4	2 (280)	8 (0.315)	A
	<b>RKS56</b>	M4	2 (280)	-	B
	<b>RKS59</b>	M8	4 (560)		
PS geared	<b>RKS54</b>	M4	2 (280)	8 (0.315)	A
	<b>RKS56</b>	M5	2.5 (350)	10 (0.394)	
	<b>RKS59</b>	M8	4 (560)	15 (0.591)	
Harmonic geared	<b>RKS54</b>	M4	2 (280)	8 (0.315)	A
	<b>RKS56</b>	M5	2.5 (350)	10 (0.394)	
	<b>RKS59</b>	M8	4 (560)	-	B



## 9.3 Installing a load

When connecting a load to the motor, align the centers of the motor output shaft and load shaft.

### Note

- When coupling the load to the motor, pay attention to the centering of the shafts, belt tension, parallelism of the pulleys, and so on. Securely tighten the coupling and pulley set screws.
- Be careful not to damage the output shaft or bearings when installing a coupling or pulley to the motor output shaft.
- Do not modify or machine the motor output shaft. Doing so may damage the bearings and destroy the motor.
- Do not apply strong force using hammer or other tools when removing the parallel key. Doing so may damage the motor output shaft and bearings (ball bearings).

### • Using a coupling

Align the centers of the motor output shaft and load shaft in a straight line.

### • Using a belt drive

Align the motor output shaft and load shaft in parallel with each other, and position both pulleys so that the line connecting their centers is at a right angle to the shafts.

### • Using a gear drive

Align the motor output shaft and gear shaft in parallel with each other, and let the gears mesh at the center of the tooth widths.

#### • Using a coupling

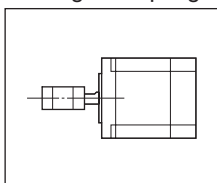

#### • Using a belt drive

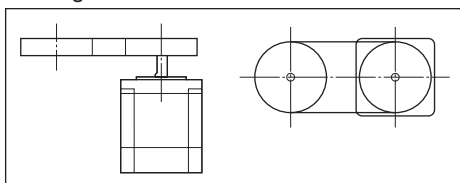

#### • Using a gear drive

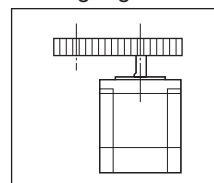

### • Using a parallel key (geared motor)

When connecting the load and gear output shaft with a key slot, secure the load using the key supplied with the gear output shaft after machining the key slot on the load.

### • Installing on the flange surface (Harmonic geared type)

With a Harmonic geared type (excluding PKE596), a load can be installed directly to the gear using the load mounting holes provided on the flange surface.

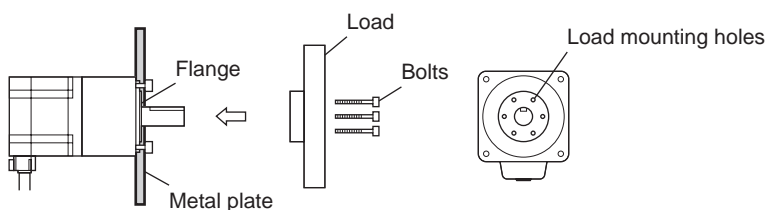

Model	Nominal size	Number of bolts	Tightening torque [N·m (oz-in)]	Effective depth of bolt [mm (in.)]
PKE543	M3	6	1.4 (198)	5 (0.2)
PKE564	M4	6	2.5 (350)	6 (0.24)

### Note

- When installing a load on the flange surface, the load cannot be mounted using the key slot in the output shaft.
- Design an appropriate installation layout so that the load will not contact the metal plate or bolts used for installing the motor.

## 9.4 Permissible radial load and permissible axial load

The radial load and the axial load on the motor's output shaft must be kept under the permissible values listed below.

**Note** Failure due to fatigue may occur when the motor bearings and output shaft are subject to repeated loading by an radial or axial load that is in excess of the permissible limit.

Type	Motor model	Gear ratio	Permissible radial load [N (lb.)]					Permissible axial load [N (lb.)] *
			Distance from the tip of motor output shaft					
			0 mm (0 in.)	5 mm (0.20 in.)	10 mm (0.39 in.)	15 mm (0.59 in.)	20 mm (0.79 in.)	
Standard	PKE543	-	35 (7.8)	44 (9.9)	58 (13)	85 (19.1)	-	2.5 (0.56) <3.9 (0.87)>
	PKE544							3.1 (0.69) <4.5 (1.01)>
	PKE545							3.7 (0.83) <5.1 (1.14)>
	PKE564		90 (20)	100 (22)	130 (29)	180 (40)	270 (60)	6.9 (1.55) <9.8 (2.2)>
	PKE566							8.8 (1.98) <11.8 (2.6)>
	PKE569							13.7 (3) <16.7 (3.7)>
	PKE596		260 (58)	290 (65)	340 (76)	390 (87)	480 (108)	18.6 (4.1) <26.5(5.9)>
	PKE599							29.4 (6.6) <37.3 (8.3)>
PKE5913	40.2 (9) <48.1 (10.8)>							
TS geared	PKE543	3.6, 7.2, 10	20 (4.5)	30 (6.7)	40 (9)	50 (11.2)	-	15 (3.3)
		20, 30	40 (9)	50 (11.2)	60 (13.5)	70 (15.7)	-	
	PKE564	3.6, 7.2, 10	120 (27)	135 (30)	150 (33)	165 (37)	180 (40)	40 (9)
		20, 30	170 (38)	185 (41)	200 (45)	215 (48)	230 (51)	
	PKE596	3.6, 7.2, 10	300 (67)	325 (73)	350 (78)	375 (84)	400 (90)	150 (33)
		20, 30	400 (90)	450 (101)	500 (112)	550 (123)	600 (135)	
PS geared	PKE545	5, 7.2, 10	73 (16.4)	84 (18.9)	100 (22)	123 (27)	-	50 (11.2)
	PKE543	25, 36, 50	109 (24)	127 (28)	150 (33)	184 (41)	-	
	PKE566	5	200 (45)	220 (49)	250 (56)	280 (63)	320 (72)	100 (22)
		7.2, 10	250 (56)	270 (60)	300 (67)	340 (76)	390 (87)	
	PKE564	25, 36, 50	330 (74)	360 (81)	400 (90)	450 (101)	520 (117)	300 (67)
	PKE599	5, 7.2, 10	480 (108)	540 (121)	600 (135)	680 (153)	790 (177)	
	PKE596	25	850 (191)	940 (210)	1050 (230)	1190 (260)	1380 (310)	
		36	930 (200)	1030 (230)	1150 (250)	1310 (290)	1520 (340)	
		50	1050 (230)	1160 (260)	1300 (290)	1480 (330)	1710 (380)	
Harmonic geared	PKE543	50, 100	180 (40)	220 (49)	270 (60)	360 (81)	510 (114)	220 (49)
	PKE564		320 (72)	370 (83)	440 (99)	550 (123)	720 (162)	450 (101)
	PKE596		1090 (240)	1150 (250)	1230 (270)	1310 (290)	1410 (310)	1300 (290)

\* The brackets < > indicate the value for the electromagnetic brake type.

### ■ Permissible moment load of the Harmonic geared type

When installing an arm or table on the flange surface, calculate the moment load using the formula below if the flange surface receives any eccentric load. The moment load should not exceed the permissible value specified in the table.

Moment load:  $M [N \cdot m (oz \cdot in)] = F \times L$

Motor model	Permissible moment load [N·m (oz-in)]
PKE543	5.6 (790)
PKE564	11.6 (1640)

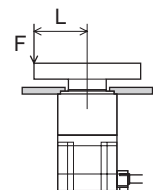

## 9.5 Installing the driver

The driver is designed so that heat is dissipated via air convection and conduction through the enclosure. Install the driver on a flat metal plate [material: aluminium, 200×200×2 mm (7.87×7.87×0.08 in.) equivalent ] having excellent heat conductivity.

There must be a clearance of at least 25 mm (0.98 in.) in the horizontal and vertical directions, between the driver and enclosure or other equipment within the enclosure. When two or more drivers are to be installed side by side, provide 20 mm (0.79 in.) and 25 mm (0.98 in.) clearances in the horizontal and vertical directions, respectively.

When installing two or more drivers in parallel, it is possible to install them closely in the horizontal direction. In this case, use the drivers in conditions that an ambient temperature is 0 to +40 °C (+32 to +104 °F) and the standstill current is 50% or less.

When installing the driver in an enclosure, use two screws (M4, not supplied) to secure the driver through the mounting holes.

- When installing drivers while keeping clearances in the horizontal and vertical directions.

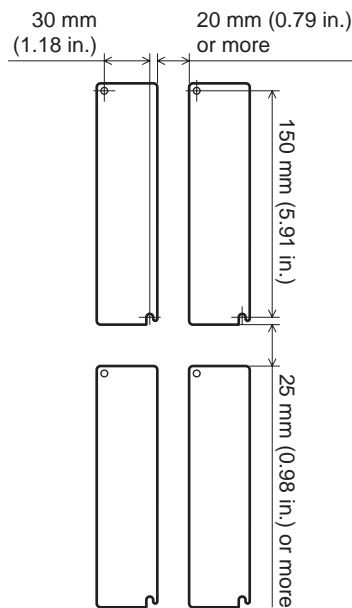

- When installing drivers closely in the horizontal direction.

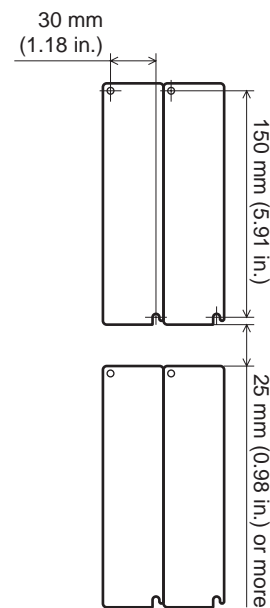

### Note

- Install the driver in an enclosure whose pollution degree is 2 or better environment, or whose degree of protection is IP54 minimum.
- Do not install any equipment that generates a large amount of heat or noise near the driver.
- Do not install the driver underneath the controller or other equipment vulnerable to heat.
- If the ambient temperature of the driver exceeds 55 °C (131 °F), improve the ventilation condition. Also, when the standstill current is set to 60%, use the driver in a condition that an ambient temperature does not exceed 50 °C (122 °F). See p.38 for the standstill current.
- Be sure to install the driver vertically (vertical position).

# 10 Connection

This chapter explains how to connect the motor, I/O signals and power supply to the driver, as well as grounding method.

## 10.1 Connection example

See p.21 for how to wire the connector.

### Note

- Have the connector plugged in securely. Insecure connections may cause malfunction or damage to the motor or driver.
- When unplugging the motor connector, do so while pressing the latches on the connector.
- When plugging/unplugging the connector, turn off the power and wait for minimum 10 minutes before doing so. Residual voltage may cause electric shock.
- Do not wire the power supply cable of the driver in the same cable duct with other power lines or motor cables. Doing so may cause malfunction due to noise.
- The lead wires of the "cable for electromagnetic brake" have polarities, so connect them in the correct polarities. If the lead wires are connected with their polarities reversed, the electromagnetic brake will not operate properly.
- If the distance between the motor and driver is extended to 15 m (49.2 ft.) or longer, use a power supply of 24 VDC±4%.
- When installing the motor to a moving part, use an accessory flexible cable offering excellent flexibility. For the flexible motor cable, refer to p.43.

### ■ Standard type

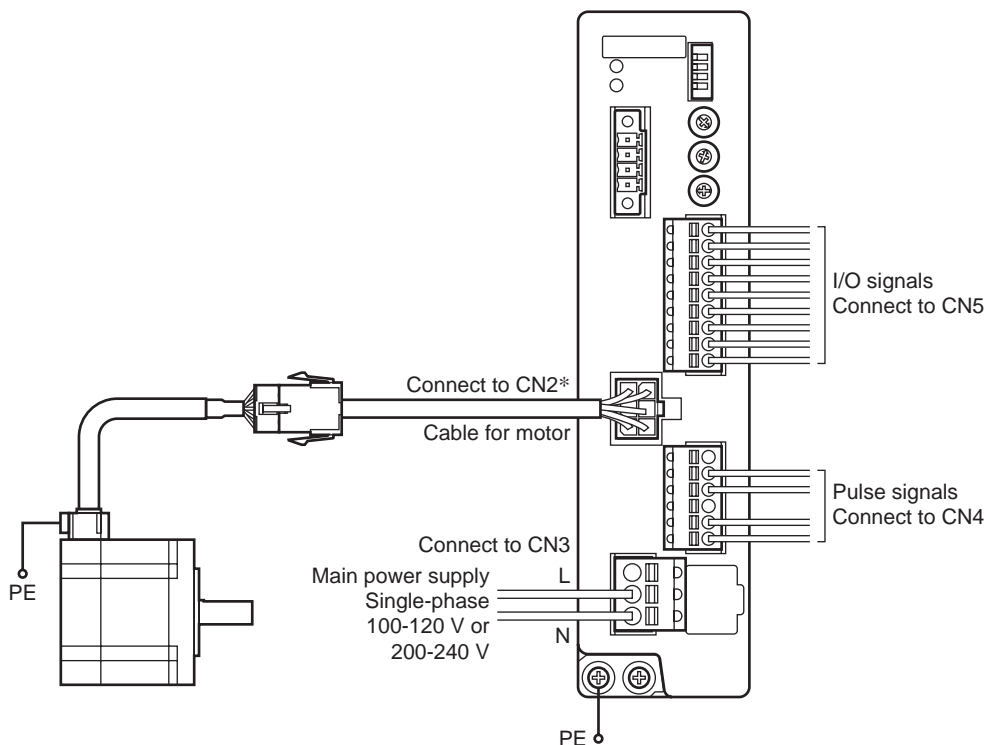

\* Keep 20 m (65.6 ft.) or less for the wiring distance between the motor and driver.

## ■ Standard type with electromagnetic brake

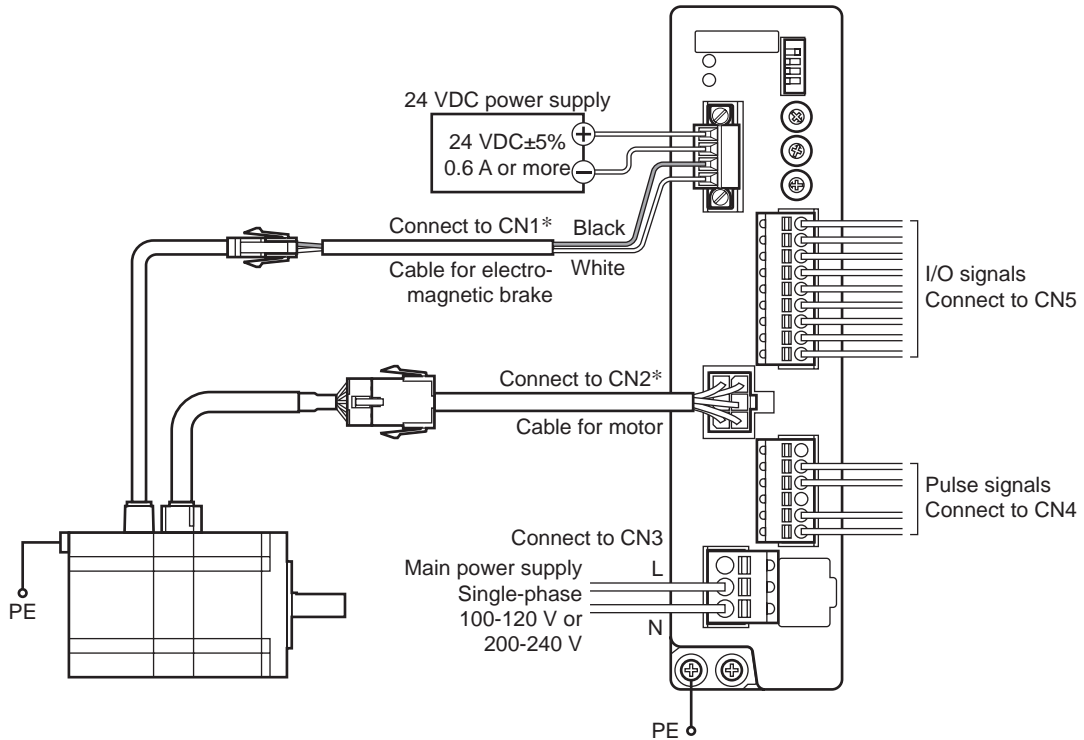

\* Keep 20 m (65.6 ft.) or less for the wiring distance between the motor and driver.

## ■ Wiring the CN1 connector

1. Insert each lead wire into the CN1 connector and tighten the screw using a screwdriver.
2. Insert the CN1 connector into CN1 and tighten the screws.

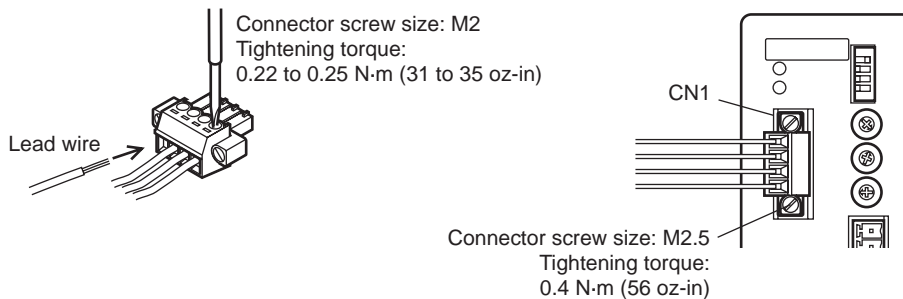

## ■ Wiring the CN3/CN4/CN5 connector

1. Insert the lead wire while pushing the button of the orange color with a screwdriver.
2. After having inserted, release the button to secure the lead wire.

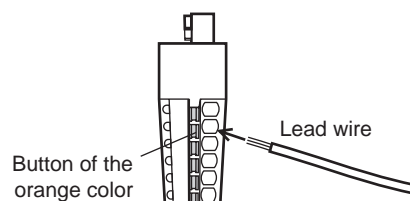

## ■ Power supply current capacity

• Single-phase 100-120 V

Model	Power supply current capacity
RKS543	2.1 A or more
RKS544	1.9 A or more
RKS545	1.9 A or more
RKS564	4.0 A or more
RKS566	3.8 A or more
RKS569	4.0 A or more
RKS596	4.9 A or more
RKS599	3.5 A or more
RKS5913	3.5 A or more

• Single-phase 200-240 V

Model	Power supply current capacity
RKS543	1.3 A or more
RKS544	1.2 A or more
RKS545	1.2 A or more
RKS564	2.4 A or more
RKS566	2.4 A or more
RKS569	2.5 A or more
RKS596	3.0 A or more
RKS599	2.2 A or more
RKS5913	2.2 A or more

## ■ Pin assignment list

• CN1

Display	Description
24V+	Connect the 24 VDC for electromagnetic brake. 24 VDC±5% 0.6 A or more
24V-	
MB1	Electromagnetic brake -
MB2	Electromagnetic brake +

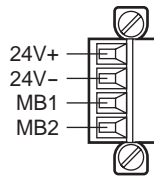

- Applicable lead wire: AWG28 to 16 (0.08 to 1.25 mm<sup>2</sup>)
- Length of the insulation cover which can be peeled: 7 mm (0.28 in.)

• CN3

Pin No.	Display	Description
1	NC	Not used.
2	L	Connect the main power supply. • Single-phase 100-120 V -15 to +10% 50/60 Hz • Single-phase 200-240 V -15 to +10% 50/60 Hz
3	N	

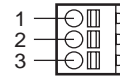

- Applicable lead wire: AWG16 to 14 (1.25 to 2.0 mm<sup>2</sup>)
- Length of the insulation cover which can be peeled: 10 mm (0.39 in.)

• CN4

Pin No.	Display	Description
1	CW (PLS) +24V	CW pulse input (Pulse input) [+24 V]
2	CW (PLS) +5V	CW pulse input (Pulse input) [+5 V or line driver]
3	CW (PLS) -	
4	CCW (DIR.) +24V	CCW pulse input (Direction input) [+24 V]
5	CCW (DIR.) +5V	CCW pulse input (Direction input) [+5 V or line driver]
6	CCW (DIR.) -	

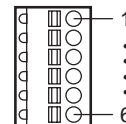

- Applicable lead wire: AWG26 to 16 (0.14 to 1.25 mm<sup>2</sup>)
- Length of the insulation cover which can be peeled: 9 mm (0.35 in.)

• CN5

Pin No.	Display	I/O	Description
1	READY	Output	Ready
2	ALM		Alarm
3	TIM		Timing
4	OUT-COM		Output common
5	AWO	Input	All winding off
6	CS		Step angle switching
7	FREE		Motor excitation off, electromagnetic brake release
8	ALM-RST		Reset alarm
9	IN-COM		Input common

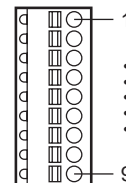

- Applicable lead wire: AWG26 to 16 (0.14 to 1.25 mm<sup>2</sup>)
- Length of the insulation cover which can be peeled: 9 mm (0.35 in.)

## ■ Connecting to a current source output circuit (PNP specifications)

- When pulse input is of line driver type

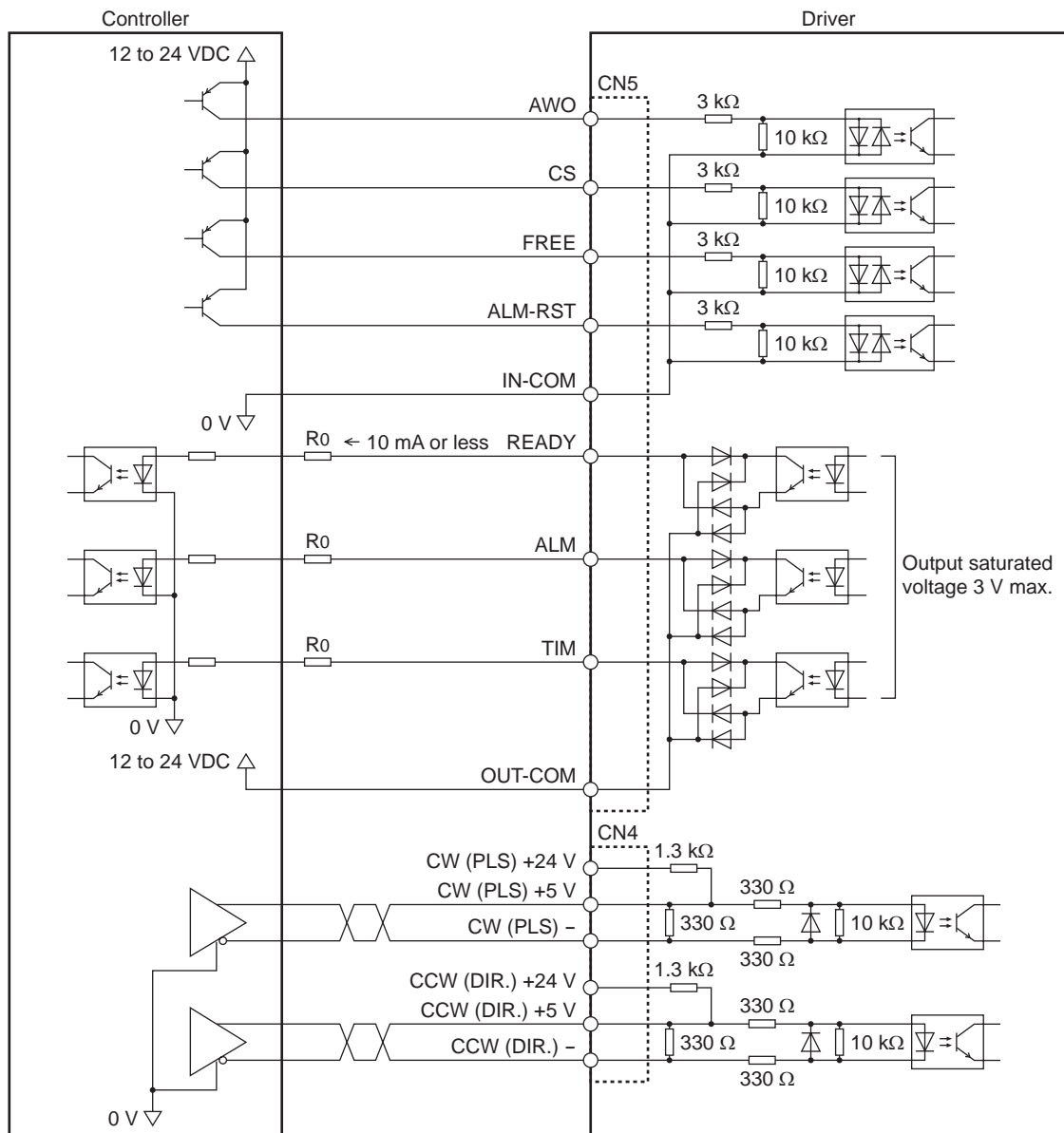

### Note

- Use input signals 12 to 24 VDC.
- Use output signals 12 to 24 VDC 10 mA or less. If the current exceeds 10 mA, connect an external resistor R0.
- The saturated voltage of the output signal is 3 VDC maximum.

- When pulse input is of 5 VDC type

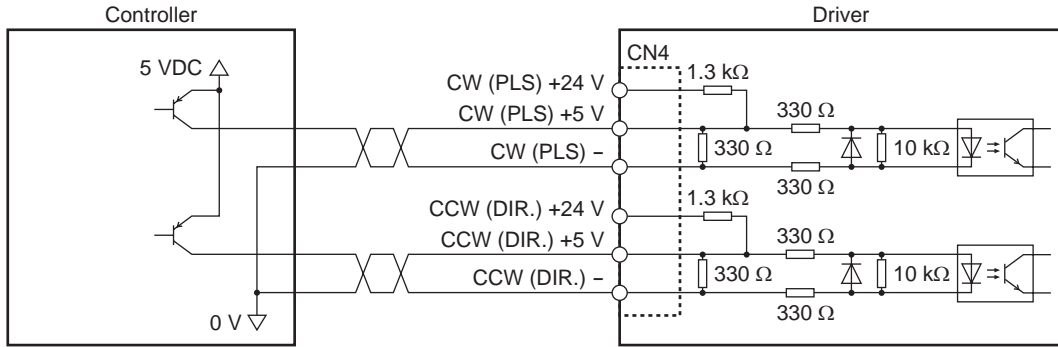

- When pulse input is of 24 VDC type

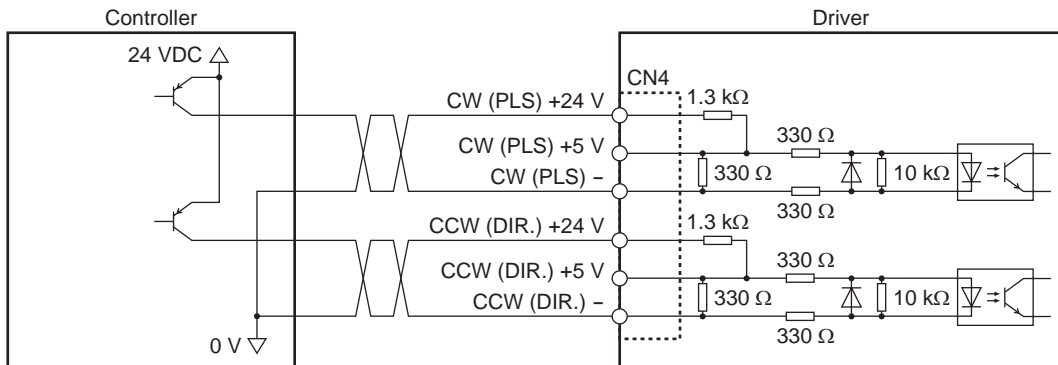



## ■ Connecting to a current sink output circuit (NPN specifications)

- When pulse input is of line driver type

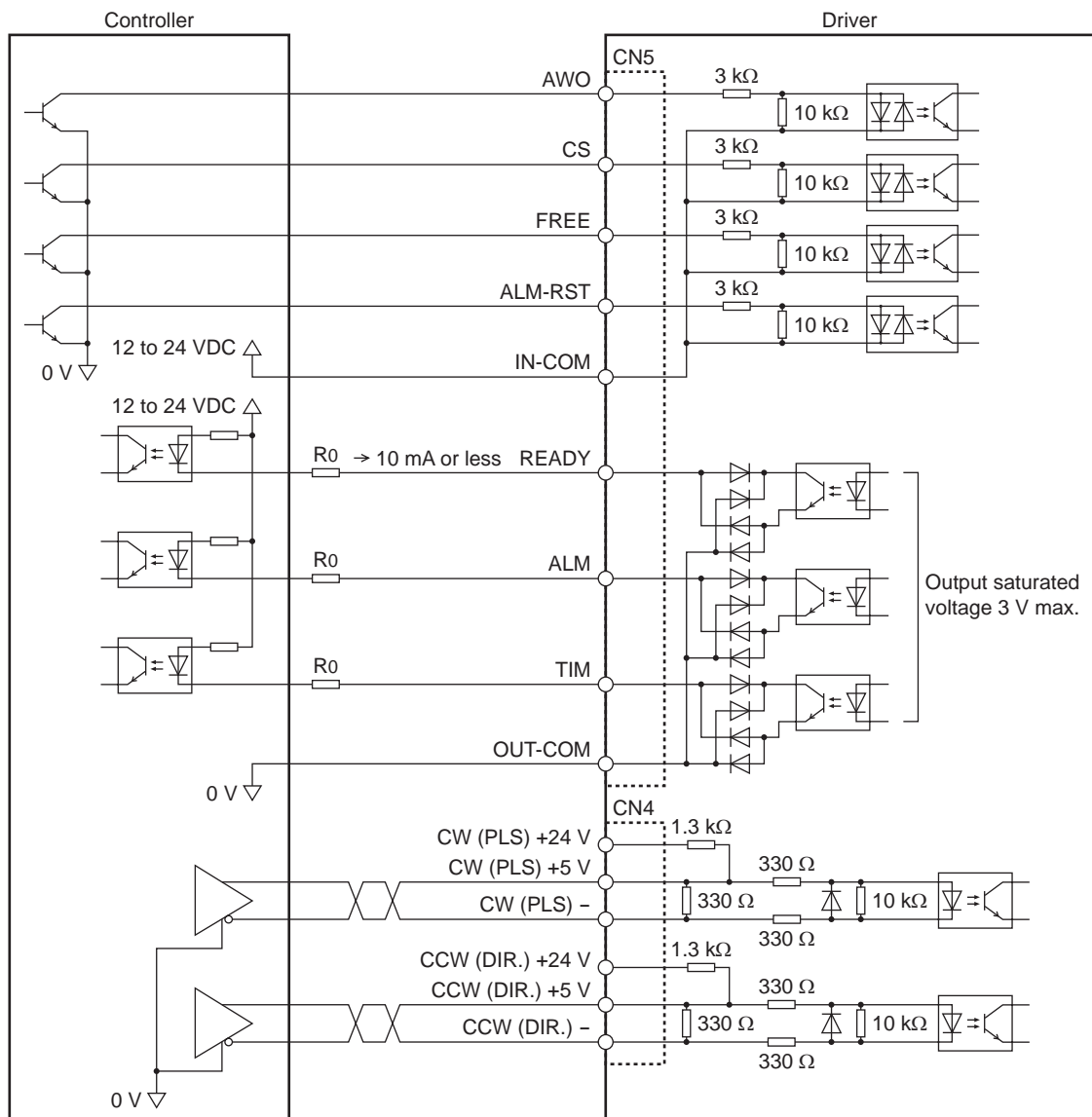

### Note

- Use input signals 12 to 24 VDC.
- Use output signals 12 to 24 VDC 10 mA or less. If the current exceeds 10 mA, connect an external resistor R0.
- The saturated voltage of the output signal is 3 VDC maximum.

- When pulse input is of 5 VDC type

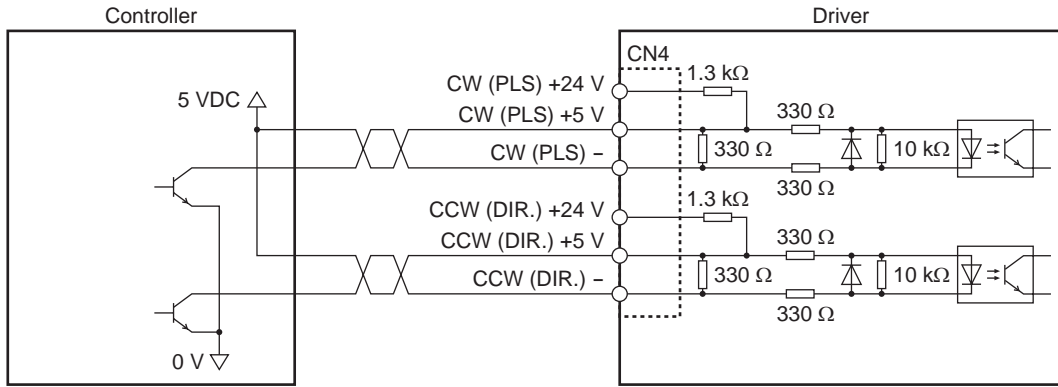

- When pulse input is of 24 VDC type

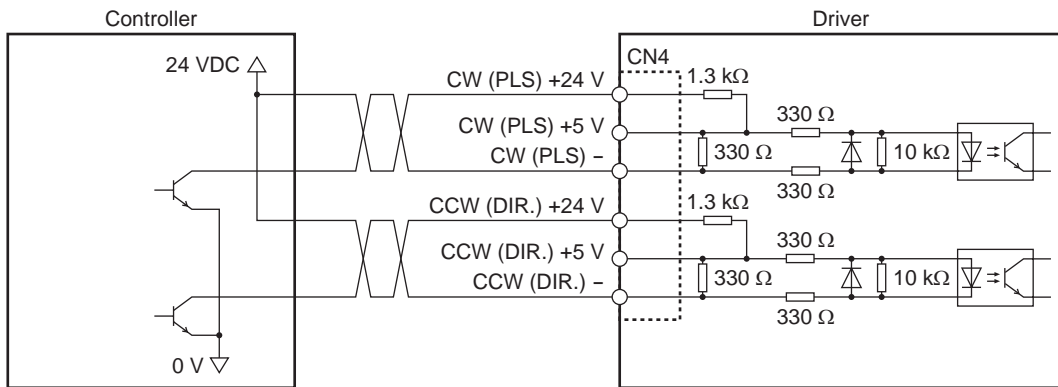

## 10.2 Grounding the motor and driver

### ■ Grounding the motor

Be sure to ground the Protective Earth Terminal of the motor.  
 Grounding wire: AWG18 (0.75 mm<sup>2</sup>) or more  
 Tightening torque: 1.2 N·m (170 oz-in)

When grounding, use a round terminal and secure it with a mounting screw with a washer. Ground wires and crimp terminals are not supplied.

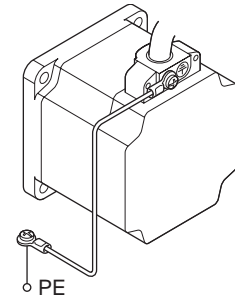

### ■ Grounding the driver

Be sure to ground the Protective Earth Terminal (screw size: M4) of the driver.  
 Grounding wire: AWG16 to 14 (1.25 to 2.0 mm<sup>2</sup>)  
 Tightening torque: 1.2 N·m (170 oz-in)

You can ground either of the two Protective Earth Terminals. The terminal that is not grounded is used as a service terminal. Use the service terminal according to your specific need, such as connecting it to the motor in order to ground the motor.

Do not share the grounding wire with a welder or any other power equipment. When grounding the Protective Earth Terminal, use a round terminal and affix the grounding point near the driver.

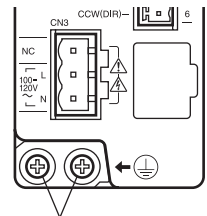

Protective Earth Terminal  
(Ground one of these terminals.)

## 10.3 Noise measures

The electrical noise is of two types: One is a noise to invade into the driver from the outside and cause the driver malfunction, and the other is a noise to emit from the driver and cause peripheral equipments malfunction. For the noise that is invaded from the outside, take measures to prevent the driver malfunction. It is needed to take adequate measures because signal lines are very likely to be affected by the noise. For the noise that is emitted from the driver, take measures to suppress it.

### ■ Measures against electrical noise

There are the following three methods mainly to take measures against the electrical noise.

#### • Noise suppression

- When relays or electromagnetic switches are used together with the system, use noise filters and CR circuits to suppress surges generated by them.
- Use an accessory cable (sold separately) when extending a wiring distance between the motor and driver. This is effective in suppressing the electrical noise emitted from the motor.
- Cover the driver by a metal plate such as aluminum. This is effective in shielding the electrical noise emitted from the driver.

#### • Prevention of noise propagation

- Connect a noise filter in the power supply cable of driver.
- Place the power lines, such as the motor and power supply cables, keeping a distance of 100 mm (3.94 in.) or more from the signal lines, and also do not bundle them or wire them in parallel. If the power cables and signal cables have to cross, cross them at a right angle.
- Use a shielded cable of AWG16 to 14 (1.25 to 2.0 mm<sup>2</sup>) or more for the power lines. Use a shielded cable of AWG26 to 16 (0.14 to 1.25 mm<sup>2</sup>) for the signal cables.
- Keep cables as short as possible without coiling and bundling extra lengths.
- To ground a shielded cable, use a metal cable clamp that will maintain contact with the entire circumference of the cable. Ground the cable clamp near the product.

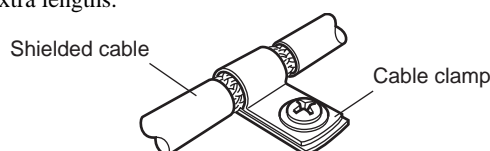

- When grounding PE terminals of multiple drivers to a grounding point, it becomes more effective to block the electrical noise since impedance on the grounding point is decreased. However, ground them so that a potential difference does not occur among the grounding points. An accessory driver cable including with a ground wire is available (sold separately). Refer to p.44 for details.
- Suppression of effect by noise propagation
  - Loop the noise propagated cable around a ferrite core. Doing so will prevent the propagated noise invades into the driver or emits from the driver. The frequency band in which an effect by the ferrite core can be seen is generally 1 MHz or more. Check the frequency characteristics of the ferrite core used. To increase the effect of noise attenuation by the ferrite core, loop the cable a lot.
  - It is recommended to change to the line driver type in order to reduce the noise effect against the pulse signal line. When the pulse signal of the controller is of the open collector type, it is possible to change to the line driver type by using an accessory pulse signal converter for noise immunity (sold separately). Refer to p.44 for details.

### ■ Noise suppression parts

#### • Noise filter

- Connect the following noise filter (or equivalent) to the power line. Doing so will prevent the propagated noise through the power line. Install the noise filter as close to the driver as possible.  
HF2010A-UPF (SOSHIN ELECTRIC CO.,LTD)  
FN2070-10-06 (Schaffner EMC)
- Use the AWG18 (0.75 mm<sup>2</sup>) or thicker wire for the input and output cables of the noise filter, and secure firmly using a cable clamp etc. so that the cable does not come off the enclosure.
- Place the input cable as far apart as possible from the output cable, and do not wire the cables in parallel. If the input and output cable are placed at a close distance or if they are wired in parallel, the noise in the enclosure affects the power cable through stray capacitance, and the noise suppressing effect will reduce.
- Connect the ground terminal of the noise filter to the grounding point, using as thick and short a wire as possible.

- When connecting a noise filter in an enclosure, wire the input cable of the noise filter as short as possible. Wiring in long distance may reduce the noise suppressing effect.

- Recommended wiring example

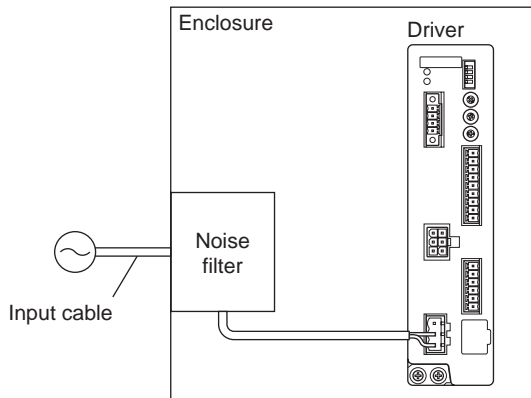

- Wiring example where the noise tends to generate

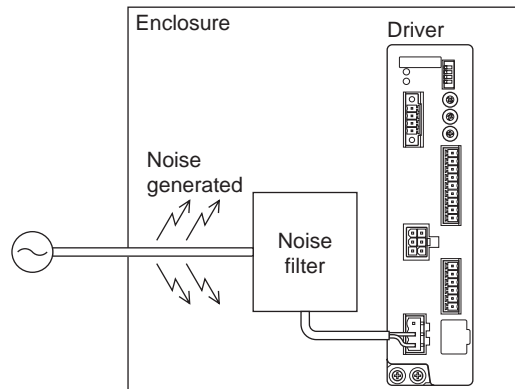

- Surge arrester

A surge arrester is effective for reduction of the surge voltage of the lightning surge generated between the AC power line and earth or between AC power lines. Connect the following surge arrester.

LT-C12G801WS (SOSHIN ELECTRIC CO.,LTD)

R·A·V-781BWZ-4 (OKAYA ELECTRIC INDUSTRIES CO., LTD.).

**Note**

When measuring dielectric strength of the equipment, be sure to remove the surge arrester, or the surge arrester may be damaged.

## ■ Noise suppression parts (accessories)

Accessories are sold separately. Refer to p.43 for details.

- Driver cable

This cable is a shielded cable for good noise immunity to connect the driver and controller. The ground wires useful to grounding are provided at both ends of the cable. The EMC measures are conducted using the Oriental Motor driver cable.

- Pulse signal converter for noise immunity

This is a noise filter for pulse signal lines. It eliminates the noise of the pulse signal and changes the pulse signal to the line driver type.

- Surge suppressor

This product is effective to suppress the surge which occurs in a relay contact part. Connect it when using a relay or electromagnetic switch. CR circuit for surge suppression and CR circuit module are provided.

## 10.4 Conformity to the EMC Directive

Effective measures must be taken against the EMI that the motor and driver may give to adjacent control-system equipment, as well as the EMS of the motor and driver itself, in order to prevent a serious functional impediment in the machinery. The use of the following installation and wiring methods will enable the motor and driver to be compliant with the EMC directive. Refer to p.11 for the applicable standards.

Oriental Motor conducts EMC measurements on its motors and drivers in accordance with the following "Example of motor and driver installation and wiring."

The user is responsible for ensuring the machine's compliance with the EMC Directive, based on the installation and wiring explained below.

- Connecting noise filter

Refer to p.27.

- Connecting surge arrester

Refer to "Surge arrester."

- Connecting the AC power line reactor

When inputting single-phase 240 V, insert a reactor (5 A, 5 mH) in the AC power line to ensure compliance with EN 61000-3-2.

- Connecting the power supply for the electromagnetic brake (electromagnetic brake motor only)

When the DC power supply for the electromagnetic brake is needed, use a power supply being compliant with the EMC Directive. Use a shielded cable for wiring. Refer to "Prevention of noise propagation" on p.27 for wire the shielded cable.

- Connecting the motor cable

Use an accessory cable (sold separately) when extending the wiring distance between the motor and driver

- Connecting the signal cable

Refer to "Prevention of noise propagation" on p.27

- How to ground

- The cable used to ground the motor, driver and noise filter must be as thick and short as possible so that no potential difference is generated.
- Choose a large, thick and uniformly conductive surface for the grounding point.
- Be sure to ground the Protective Earth Terminal of the motor and driver. Refer to p.25 for grounding method.

- Example of motor and driver installation and wiring

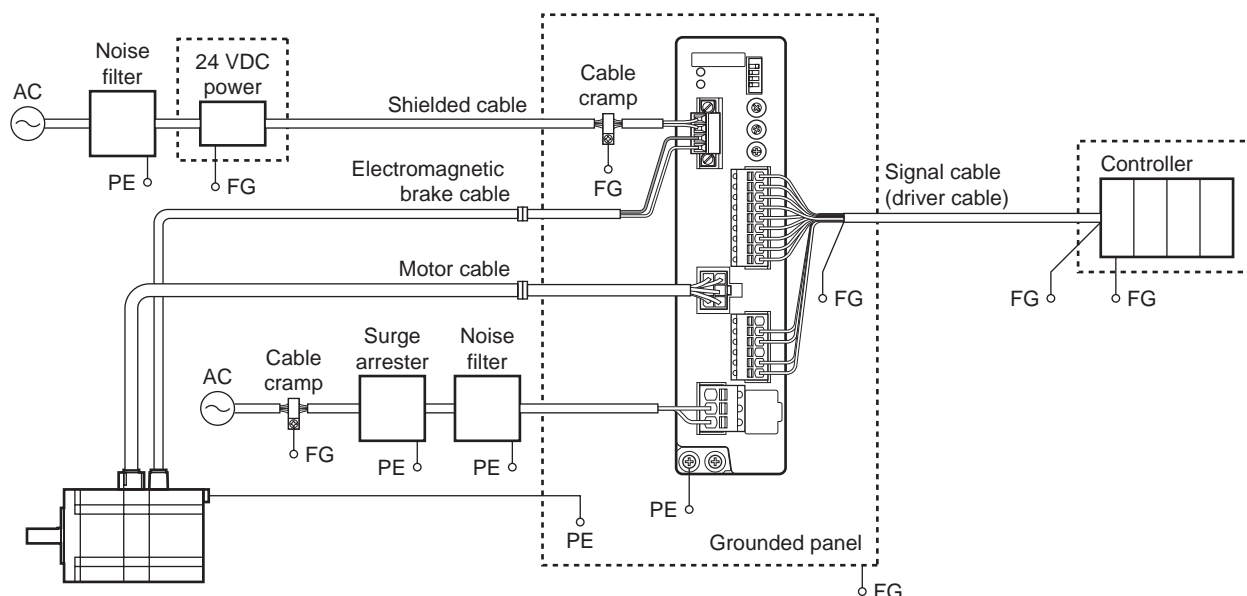

- Precautions about static electricity

Static electricity may cause the driver to malfunction or suffer damage. While the driver is receiving power, handle the driver with care and do not come near or touch the driver.

Always use an insulated screwdriver to adjust the driver's switches.

**Note**

The driver uses parts that are sensitive to electrostatic charge. Before touching the driver, turn off the power to prevent electrostatic charge from generating. If an electrostatic charge is impressed on the driver, the driver may be damaged.

# 11 Guidance

If you are new to the **RK II** Series pulse input type, read this section to understand the operating methods along with the operation flow.

**Note** | Before operating the motor, check the condition of the surrounding area to ensure safety.

## 11.1 Standard type

### STEP 1 Check the installation and connection

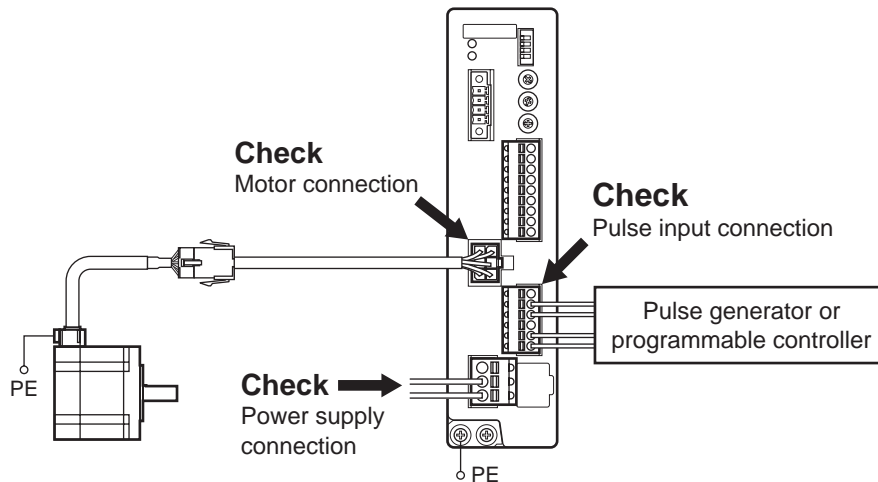

### STEP 2 Turn on the power and operate the motor

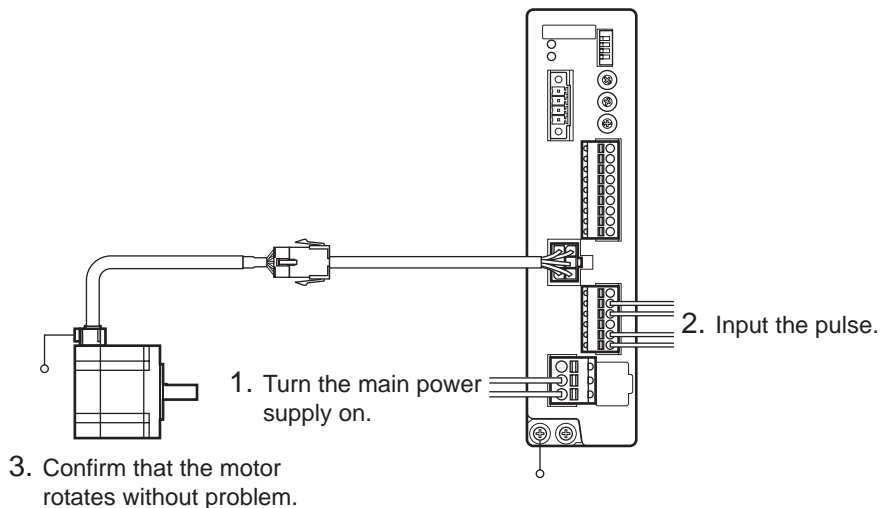

### STEP 3 Were you able to operate the motor properly?

How did it go? Were you able to operate the motor properly? If the motor does not function, check the following points:

- Is any alarm present?
- Are the power supply, motor and pulse signal connected securely?

## 11.2 Standard type with electromagnetic brake

### STEP 1 Check the installation and connection

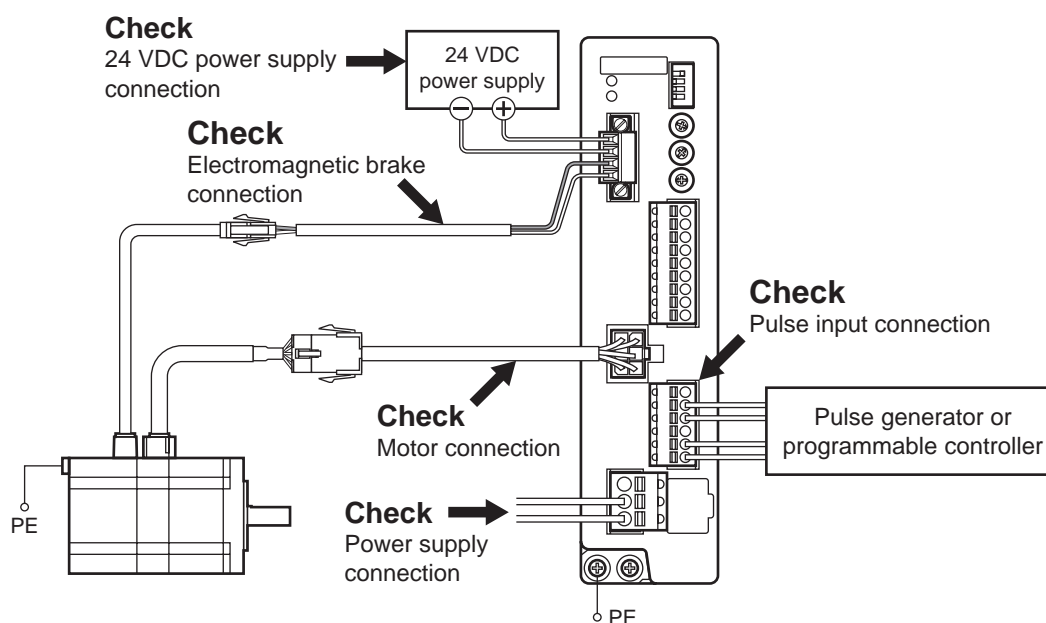

### STEP 2 Turn on the power and operate the motor

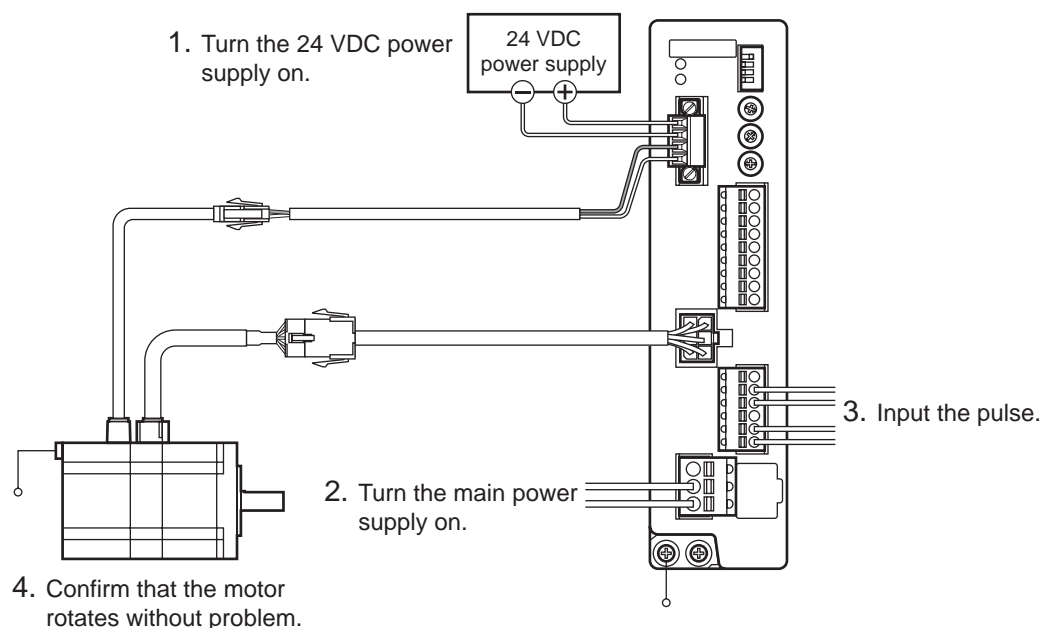

### STEP 3 Were you able to operate the motor properly?

How did it go? Were you able to operate the motor properly? If the motor does not function, check the following points:

- Is any alarm present?
- Is the 24 VDC power supply for the electromagnetic brake connected without fail?
- Are the power supply, motor and pulse signal connected securely?

# 12 Explanation of I/O signals

## 12.1 Input signals

The following input signals of the driver are photocoupler inputs. The signal state represents the "ON: Carrying current" or "OFF: Not carrying current" state of the internal photocoupler rather than the voltage level of the signal.

### ■ CW (PLS) input, CCW (DIR.) input

These input serve as the CW and CCW inputs in the 2-pulse input mode, or PLS and DIR inputs in the 1-pulse input mode. They are common to all pulse input types including 5 VDC input, 24 VDC input and line driver input.

Set the pulse input mode of the driver according to the pulse output mode of the controller (pulse generator) used with the driver. See p.37 for how to set the pulse input mode.

When inputting the pulse, check the READY input is turned ON.

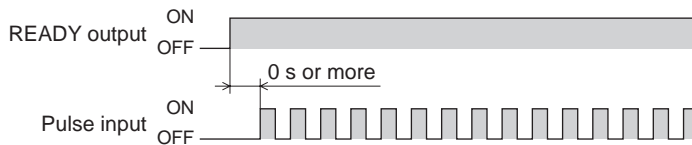

**Note** | When the motor is at standstill, be sure to keep the photocoupler in OFF state.

- Maximum input pulse frequency
  - When the controller is of line driver type: 500 kHz (duty cycle is 50%)
  - When the controller is of open-collector type: 250 kHz (duty cycle is 50%)
- 2-pulse input mode

When the CW input is turned from OFF to ON, the motor will rotate by one step in CW direction.

When the CCW input is turned from OFF to ON, the motor will rotate by one step in CCW direction.

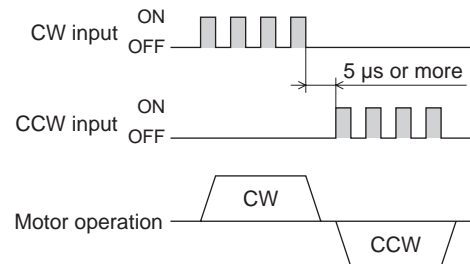

**Note** | Do not input the CW signal and CCW signal simultaneously. If the other signal is input while one of the signals is ON, the motor cannot operate normally.

- 1-pulse input mode
  - When the PLS input is turned from OFF to ON while the DIR input is ON, the motor will rotate by one step in CW direction.
  - When the PLS input is turned from OFF to ON while the DIR input is OFF, the motor will rotate by one step in CCW direction.

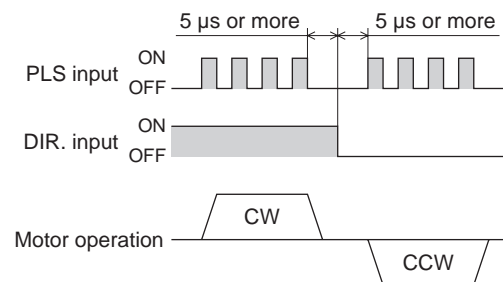



## ■ AWO input

When the AWO input is turned ON, current supplied to the motor will be cut off, thereby allowing the motor output shaft to be turned by hand. However, if the electromagnetic brake motor is used, the electromagnetic brake continues to hold the position.

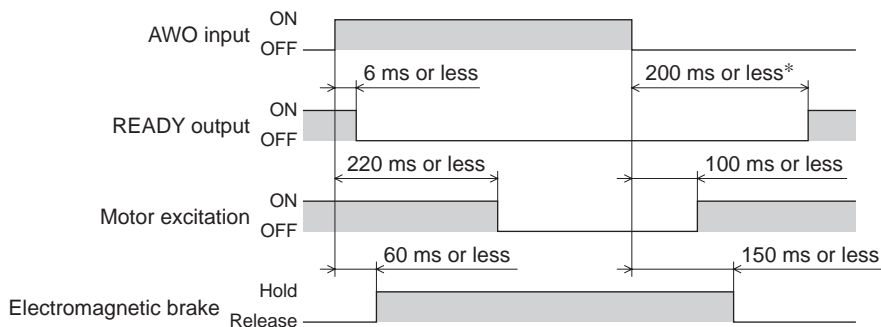

\* 1.2 sec or less for the electromagnetic brake type

## ■ FREE input

When the FREE input is turned ON, the motor current will be cut off. The motor will lose its holding torque, and the output shaft can be turned manually. When an electromagnetic brake motor is used, the electromagnetic brake will be released.

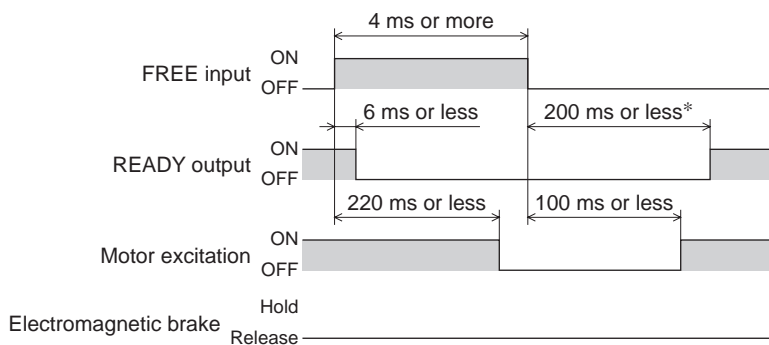

\* 1.2 sec or less for the electromagnetic brake type

## ■ ALM-RST input

When an alarm generates, the motor will stop. When the ALM-RST input is turned from OFF to ON, the alarm will be reset. (This signal will become effective when turning from OFF to ON.) Always reset an alarm after removing the cause of the alarm and after ensuring safety.

Note that some alarms cannot be reset with the ALM-RST input. See p.39 for alarm descriptions.

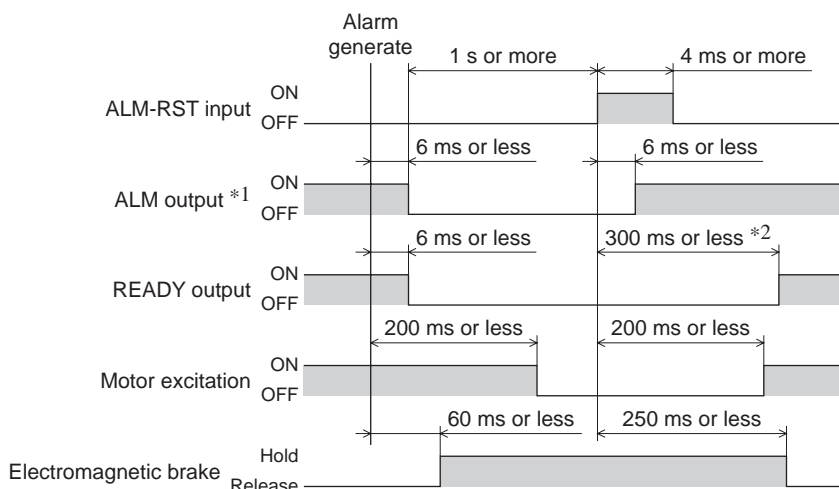

\*1 ALM output is normally closed. It is ON during normal operation and it turns OFF when an alarm generates.

\*2 1.3 sec or less for the electromagnetic brake type

### ■ CS input

When turning the CS input ON, the motor rotates at a basic step angle. With the standard type, the basic step angle is 0.72°.

When turning the CS input OFF, the motor rotates at the step angle set by the step angle setting switch (STEP). Refer to p.37 for step angle setting switch.

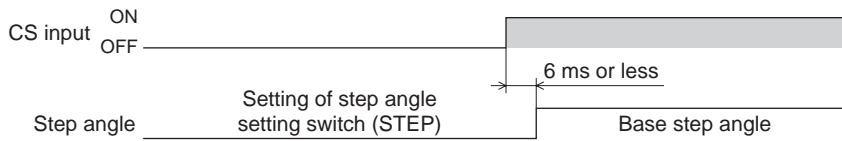

**Note**

- Do not change the CS input while operating. The motor may lose its synchronism, causing position deviation or standstill of the motor.
- When changing the step angle using the CS input, do so while the TIM output is ON.

## 12.2 Output signals

The driver outputs signals are photocoupler/open-collector output. The signal state represents the "ON: Carrying current" or "OFF: Not carrying current" state of the internal photocoupler rather than the voltage level of the signal.

### ■ TIM output

This signal turns ON when the motor is at its excitation home. The present motor position will reset to the excitation home when turning on the driver power.

If the base step angle of the motor is 0.72°, the TIM output will turn ON every time the motor moves by 7.2° from its excitation home in synchronization with the internal oscillation pulse.

If the "TIM signal detection with home-seeking" parameter is set to "1: Enable," when detecting the mechanical home in the equipment, the tolerance for the motor stop positions in a detection range of the home sensor can be reduced and the further accurate mechanical home can be detected.

Example of the TIM output when the motor step angle is 0.72° (resolution is 500 P/R)

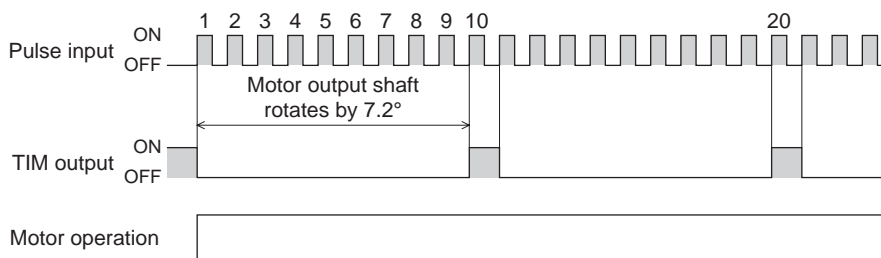

Motor type	Number of divisions		TIM output
	1	10	
Motor with 0.72°/step base step angle	0.72°	0.072°	every 7.2°
Geared motor with 7.2 gear ratio	0.1°	0.01°	every 1°

**Note**

- When using the TIM output, keep the input pulse frequency to be 500 Hz or less.
- When using the TIM output, set the pulse or step angle so that the motor output shaft stops at an integral multiple of 7.2°.

### ■ ALM output

When an alarm generates, the ALM output will turn OFF. At the same time, the ALARM LED of the driver will blink and the motor current will be cut off and the motor will stop. The ALM output is normally closed. See p.39 for alarm.

### ■ READY output

When the driver becomes ready, the READY output turns ON. Input the pulse to the driver after the READY output has turned ON. The READY output turns ON when all of the following conditions are satisfied.

- AWO input is OFF
- FREE input is OFF
- An alarm is not present.
- When an electromagnetic brake motor is used, the electromagnetic brake is released.

## 12.3 Timing charts

### ■ Standard type

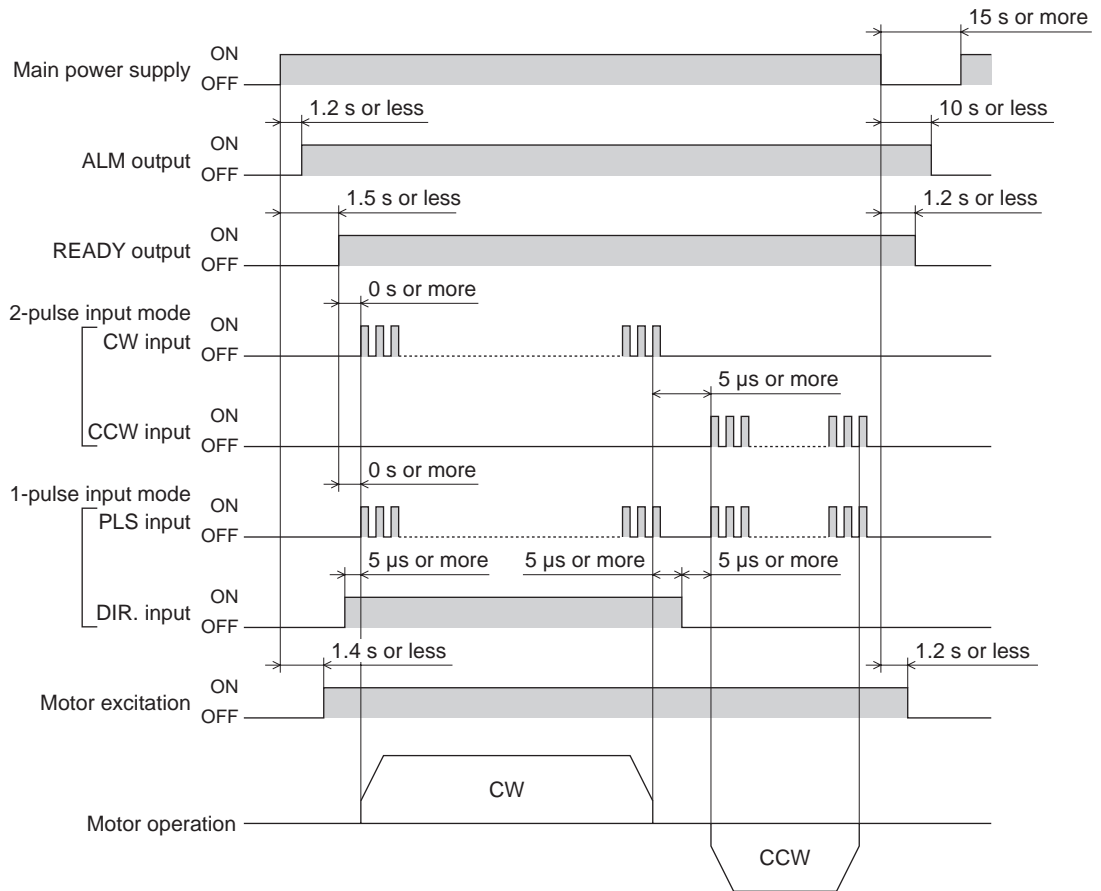

■ Standard type with electromagnetic brake

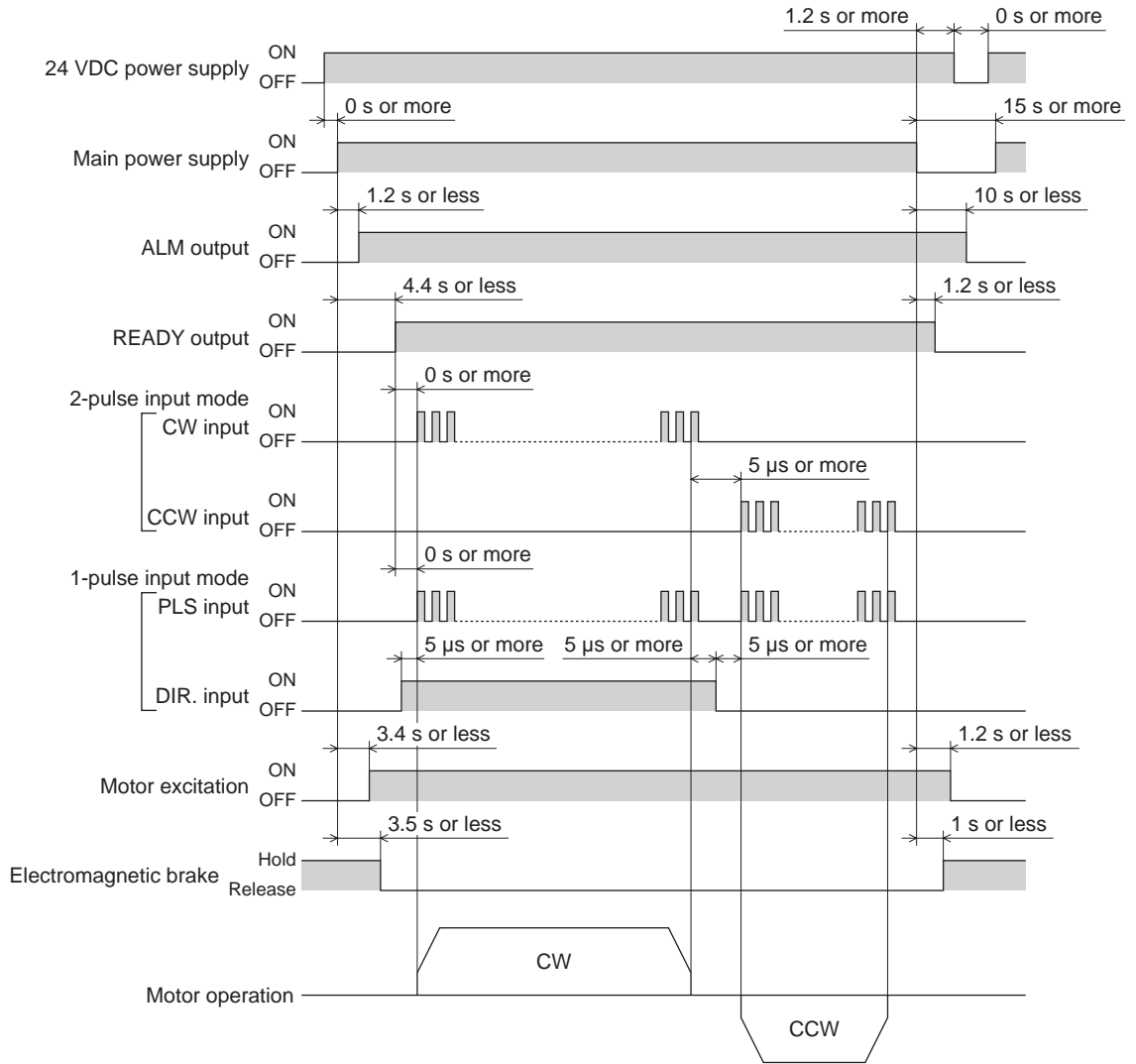

# 13 Setting

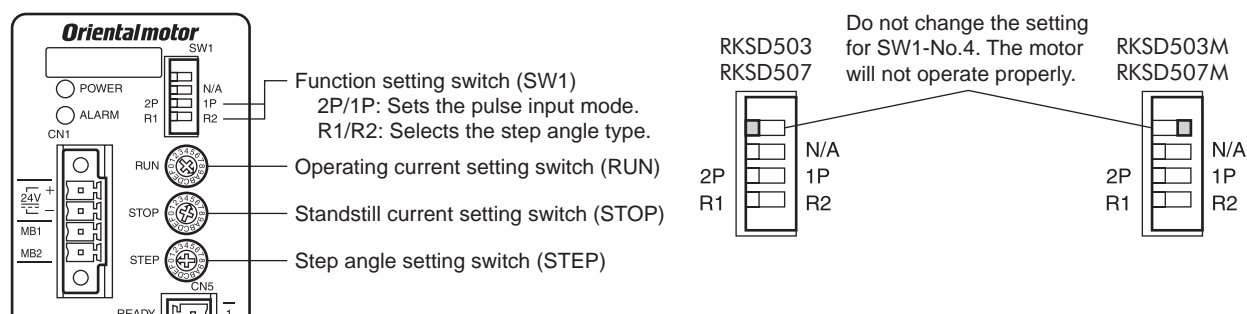

## 13.1 Pulse input mode

Set a desired pulse input mode of the driver according to the pulse output mode of the controller (pulse generator) used with the driver. Set a desired mode using the SW1-2P/1P of the function setting switch.

The factory setting of the pulse input mode depends on the destination country.

**Note** Be sure to turn off the driver power before setting the switches. The new setting of the function setting switch will become effective after the power is cycled.

## 13.2 Step angle

Set the step angle from among the 32 preset levels using the step angle setting switch (STEP) and function setting switch (SW1).

The step angle refers to the angle that the motor rotates when one pulse is input. For example, when the step angle is  $0.72^\circ$ , the motor rotates  $0.72^\circ$  per one pulse.

See the following tables for the step angles that can be set.

Factory setting Step angle setting switch (STEP): 0  
Function setting switch (SW1): R1

- When the function setting switch (SW1) is set to R1.

Dial setting of the STEP	Resolution [P/R]	Step angle [°]	Number of divisions
0	500	0.72	1
1	1000	0.36	2
2	1250	0.288	2.5
3	2000	0.18	4
4	2500	0.144	5
5	4000	0.09	8
6	5000	0.072	10
7	10000	0.036	20
8	12500	0.0288	25
9	20000	0.018	40
A	25000	0.0144	50
B	40000	0.009	80
C	50000	0.0072	100
D	62500	0.00576	125
E	100000	0.0036	200
F	125000	0.00288	250

- When the function setting switch (SW1) is set to R2.

Dial setting of the STEP	Resolution [P/R]	Step angle [°]	Number of divisions
0	200	1.8	0.4
1	400	0.9	0.8
2	600	0.6	1.2
3	800	0.45	1.6
4	1200	0.3	2.4
5	1600	0.225	3.2
6	3200	0.1125	6.4
7	6000	0.06	12
8	6400	0.05625	12.8
9	7200	0.05	14.4
A	8000	0.045	16
B	12000	0.03	24
C	12800	0.028125	25.6
D	16000	0.0225	32
E	25600	0.0140625	51.2
F	200000	0.0018	400

- Note**
- Be sure to turn off the driver power before setting the switches. The new setting of the function setting switch will become effective after the power is cycled.
  - For the geared type, the actual step angle is the value divided the step angle by the gear ratio.

### 13.3 Operating current

Set the maximum output current of the driver from among the 11 preset levels using the operating current setting switch (RUN). If the load is small and there is an ample allowance for torque, motor temperature rise can be suppressed by setting a lower operating current.

The operating current is a value in which the operating current rate is multiplied by the rated current (100%).

Factory setting A (100%)

Dial setting	Operating current rate (%)	Dial setting	Operating current rate (%)
0	0	8	80
1	10	9	90
2	20	A	100
3	30	B	
4	40	C	
5	50	D	
6	60	E	
7	70	F	

### 13.4 Standstill current

When the motor stops, the motor current drops to the standstill current.

Set the standstill current from among the 7 preset levels using the standstill current setting switch (STOP).

The standstill current is a value in which the standstill current rate is multiplied by the rated current (100%).

Factory setting 5 (50%)

Dial setting	Standstill current rate (%)	Dial setting	Standstill current rate (%)
0	0	8	60
1	10	9	
2	20	A	
3	30	B	
4	40	C	
5	50	D	
6	60	E	
7		F	

**Note**

- When installing two or more drivers in parallel, it is possible to install them closely in the horizontal direction. In this case, use the drivers in conditions that an ambient temperature is 0 to +40 °C (+32 to +104 °F) and the standstill current is 50% or less.
- When the standstill current is set to 60%, use the driver in a condition that an ambient temperature does not exceed 50 °C (122 °F).

# 14 Alarms

When an alarm generates, the ALM output is turned OFF and the motor current is cut off, and thereby the motor holding torque will be lost.

At the same time, the ALARM LED of the driver will blink. The cause of the alarm can be checked by counting the number of times the ALARM LED blinks.

Example: Overvoltage alarm (number of blinks: 3)

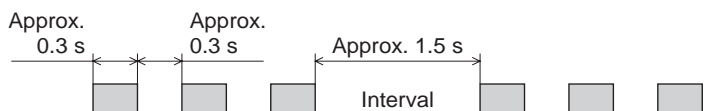

## ■ Alarm reset

Before resetting an alarm, always remove the cause of the alarm and ensure safety, and perform one of the reset operations specified below.

- Turn the ALM-RST input to OFF and then ON. (The alarm will be reset at the ON edge of the input.)
- Cycle the power.

### Note

Some alarms cannot be reset with the ALM-RST input. To reset these alarms, you must cycle the power.

## ■ Alarm list

No. of ALARM LED blinks	Alarm type	Cause	Remedial action	Reset using the ALM-RST input	Motor status
2	Main circuit overheat	The internal temperature of the driver exceeded 85 °C (185 °F).	Review the ventilation condition in the enclosure.	Possible	No holding power
3	Overvoltage	<ul style="list-style-type: none"> <li>• A voltage exceeding the specification value was applied.</li> <li>• A large inertial load was stopped abruptly or vertical operation was performed</li> </ul>	<ul style="list-style-type: none"> <li>• Check the input voltage of the power supply.</li> <li>• If this alarm generates during operation, reduce the load or make the acceleration/ deceleration time longer.</li> </ul>	Not possible	
4	Command pulse error	The command pulse frequency is too high.	Lower the command pulse frequency.	Possible	
5	Overcurrent	The motor, cable or driver output circuit was shorted.	Turn off the power and check the motor cable and driver for shorting, and then cycle the power.	Not possible	
6	Undervoltage	The power supply was cut off momentarily or the voltage became low.	Check the input voltage of the power supply.	Possible	
7	Electromagnetic brake automatic control error	The 24 VDC power supply is not connected.	Connect 24 VDC power supply to CN1.		
		<ul style="list-style-type: none"> <li>• The electromagnetic brake is not connected.</li> <li>• Connection error in the electromagnetic brake.</li> </ul>	Connect the electromagnetic brake correctly.		
		The setting of the driver function setting switch (SW1-No.4) was changed. [for the RKSD503 and RKSD507 only]	Do not change the setting.		
9	Electrolytic capacitor error	The electrolytic capacitor on the main circuit was damaged.	Contact your nearest Oriental Motor sales office.	Not possible	
	EEPROM error	The stored data was damaged.			
Lit	CPU error	CPU malfunctioned.	Cycle the power.		

# 15 Inspection

---

It is recommended that periodic inspections be conducted for the items listed below after each operation of the motor. If an abnormal condition is noted, discontinue any use and contact your nearest Oriental Motor sales office.

## ■ During inspection

- Are any of motor mounting screws loose?
- Check for any unusual noises in the motor's bearings (ball bearings) or other moving parts.
- Are there any scratches, signs of stress or loose driver connection in the motor cable?
- Are the motor's output shaft and load shaft out of alignment?
- Are the openings in the driver blocked?
- Are any of the mounting screws or connection parts of the driver loose?
- Is there attachment of dust, etc., on the driver?
- Are there any strange smells or appearances within the driver?

**Note** | The driver uses semiconductor elements, so be extremely careful when handling them. Static electricity may damage the driver.



# 16 Troubleshooting and remedial actions

During motor operation, the motor or driver may fail to function properly due to an improper speed setting or wiring. When the motor cannot be operated correctly, refer to the contents provided in this section and take appropriate action. If the problem persists, contact your nearest Oriental Motor sales office.

Phenomenon	Possible cause	Remedial action
<ul style="list-style-type: none"> <li>The motor is not excited.</li> <li>The motor output shaft can be moved by hand. (When an electromagnetic brake motor is used, the motor shaft can be moved easily by releasing the electromagnetic brake.)</li> </ul>	Connection error in the motor.	Check the connections between the driver and motor.
	The AWO input is turned ON.	Turn the AWO input OFF and confirm that the motor output shaft will be excited.
	The FREE input is turned ON.	Turn the FREE input OFF.
The motor does not operate.	Pulse signals are not connected properly.	Check the connection between the controller and driver.
	The CW input and CCW input are turned ON simultaneously in the 2-pulse input mode.	Each pulse signal input should specify either the CW input or CCW input, but not both. Make sure the terminal not receiving the signal input remains OFF.
	The pulse signal is connected to DIR input in the 1-pulse input mode.	Connect the pulse signal to the PLS input.
	The electromagnetic brake is not released. (electromagnetic brake type)	<ul style="list-style-type: none"> <li>Connect 24 VDC power supply to CN1.</li> <li>Connect the electromagnetic brake correctly.</li> </ul>
The motor rotates in the direction opposite to the specified direction.	The CW input and CCW input are connected in reverse in the 2-pulse input mode.	Connect CW pulse signals via the CW input, and connect CCW pulse signals via the CCW input.
	The DIR input is set in reverse in the 1-pulse input mode.	Turn the DIR input ON to cause the motor to rotate in CW direction, and turn the input OFF to cause the motor to rotate in CCW direction.
The gear output shaft rotates in the direction opposite to the motor.	A gear that rotates in the direction opposite to the motor shaft is used.	<ul style="list-style-type: none"> <li>With <b>TS</b> geared motors, the gear output shaft rotates in the direction opposite to the motor when the gear ratio is 20 or 30.</li> <li>With Harmonic geared motors, the gear output shaft always rotates in the direction opposite to the motor.</li> </ul>
The motor operation is unstable.	Connection error in the motor or power supply.	Check the connections between the driver, motor and power supply.
	The operating current or standstill current is too low.	Return the operating current or standstill current to its initial value and check. If the current is too low, the motor torque will also be too low and operation will be unstable.
	Pulse signals are not connected properly.	Check the connection between the controller and driver.
The motor loses its synchronism while accelerating, decelerating or operating.	Excessive load or large fluctuation in the load.	Check for a large fluctuation in the load during operation. If no problem is occurred even when the operating pulse speed has been set to the low-speed range that is higher torque area, check the load condition.
	The centers of the motor's output shaft and load shaft are not aligned.	Check the connection condition of the motor output shaft and load shaft.
	The starting pulse speed is too high.	Reduce the starting pulse speed to a level at which starting becomes stable.
	The acceleration (deceleration) time is too short.	Increase the acceleration (deceleration) time to a level at which starting becomes stable.
	Effect of noise.	See p.27 and take measures.
Motor vibration is too great.	The centers of the motor's output shaft and load shaft are not aligned.	Check the connection condition of the motor output shaft and load shaft.
	Motor is resonating.	If the vibration decreases when the operating pulse speed is changed, it means the motor is resonating. Change the operating pulse speed or select a smaller step angle.

Phenomenon	Possible cause	Remedial action
The TIM output does not turn ON.	CS input is switched while TIM output is OFF.	Switch the CS input while TIM output is ON.
The electromagnetic brake is not released. (electromagnetic brake type)	The 24 VDC power supply is not connected.	Connect 24 VDC power supply to CN1.
	<ul style="list-style-type: none"> <li>• The electromagnetic brake is not connected.</li> <li>• Connection error in the electromagnetic brake.</li> </ul>	Connect the electromagnetic brake correctly.
	The setting of the driver function setting switch (SW1-No.4) was changed. [for the RKSD503M and RKSD507M only]	Do not change the setting.

# 17 Accessories (sold separately)

## ■ Motor cable

The **RK II Series** has models supplied with a "cable for motor" to connect the motor and driver, and also it has models without a "cable for motor." "If the distance between the motor and driver is extended more than 3 m (9.8 ft.) when using the model with a ""cable for motor,"" use the connection cable set. In the case of the model without a ""cable for motor,"" use an extension cable set."

The cable set for electromagnetic brake motor consists of two cables, one for motor and the other for electromagnetic brake.

When installing the motor on a moving part, use a flexible cable offering excellent flexibility.

- Extending the wiring length using a connection cable set  
Do not use the supplied cable.
- Extending the wiring length using an extension cable set  
Connect an extension cable to the supplied cable.

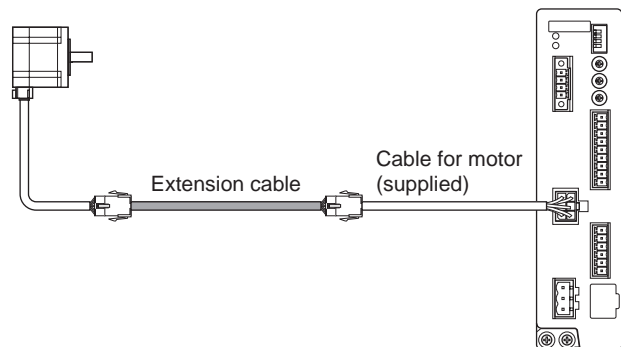
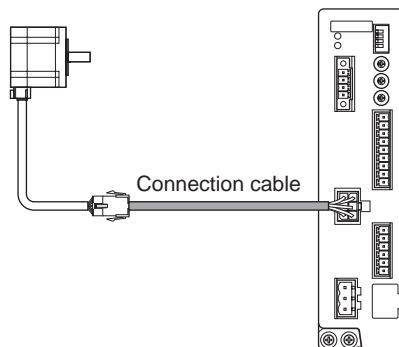

**Note** When extending the wiring length by connecting an extension cable to the supplied cable, keep the total cable length to 20 m (65.6 ft.) or less.

### • Connection cable set

The cable set for electromagnetic brake motor consists of two cables, one for motor and the other for electromagnetic brake.

- Connection cable set  
For standard motor

Model	Length [m (ft.)]
<b>CC010VPF</b>	1 (3.3)
<b>CC020VPF</b>	2 (6.6)
<b>CC030VPF</b>	3 (9.8)
<b>CC050VPF</b>	5 (16.4)
<b>CC070VPF</b>	7 (23.0)
<b>CC100VPF</b>	10 (32.8)
<b>CC150VPF</b>	15 (49.2)
<b>CC200VPF</b>	20 (65.6)

- Flexible connection cable set  
For standard motor

Model	Length [m (ft.)]
<b>CC010VPR</b>	1 (3.3)
<b>CC020VPR</b>	2 (6.6)
<b>CC030VPR</b>	3 (9.8)
<b>CC050VPR</b>	5 (16.4)
<b>CC070VPR</b>	7 (23.0)
<b>CC100VPR</b>	10 (32.8)
<b>CC150VPR</b>	15 (49.2)
<b>CC200VPR</b>	20 (65.6)

- Connection cable set  
For electromagnetic brake motor

Model	Length [m (ft.)]
<b>CC010VPFB</b>	1 (3.3)
<b>CC020VPFB</b>	2 (6.6)
<b>CC030VPFB</b>	3 (9.8)
<b>CC050VPFB</b>	5 (16.4)
<b>CC070VPFB</b>	7 (23.0)
<b>CC100VPFB</b>	10 (32.8)
<b>CC150VPFB</b>	15 (49.2)
<b>CC200VPFB</b>	20 (65.6)

- Flexible connection cable set  
For electromagnetic brake motor

Model	Length [m (ft.)]
<b>CC010VPRB</b>	1 (3.3)
<b>CC020VPRB</b>	2 (6.6)
<b>CC030VPRB</b>	3 (9.8)
<b>CC050VPRB</b>	5 (16.4)
<b>CC070VPRB</b>	7 (23.0)
<b>CC100VPRB</b>	10 (32.8)
<b>CC150VPRB</b>	15 (49.2)
<b>CC200VPRB</b>	20 (65.6)

**Connector pin assignments of connection cable**

• Pin assignment of "cable for motor"

Pin No.	Color	Lead size
1	Black	AWG22 (0.3 mm <sup>2</sup> )
2	Red	
3	Yellow	
4	Blue	
5	Orange	
6	Green	

• Motor side

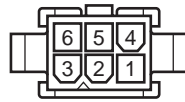

Model: 5559-06P-210 (Molex)

• Driver side

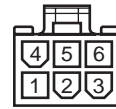

Mode: 5557-06P-210 (Molex)

• Pin assignment of "cable for electromagnetic brake"

Pin No.	Color	Lead size
1	White	AWG20 (0.5 mm <sup>2</sup> )*
2	Black	

\* AWG21 (0.5 mm<sup>2</sup>) for flexible cable

• Motor side

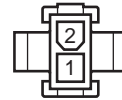

Model: 5559-02P-210 (Molex)

• Extension cable set

The cable set for electromagnetic brake motor consists of two cables, one for motor and the other for electromagnetic brake.

• Extension cable set  
For standard motor

Model	Length [m (ft.)]
CC010VPF	1 (3.3)
CC020VPF	2 (6.6)
CC030VPF	3 (9.8)
CC050VPF	5 (16.4)
CC070VPF	7 (23.0)
CC100VPF	10 (32.8)
CC150VPF	15 (49.2)

• Extension cable set  
For electromagnetic brake motor

Model	Length [m (ft.)]
CC010VPFBT	1 (3.3)
CC020VPFBT	2 (6.6)
CC030VPFBT	3 (9.8)
CC050VPFBT	5 (16.4)
CC070VPFBT	7 (23.0)
CC100VPFBT	10 (32.8)
CC150VPFBT	15 (49.2)

• Flexible extension cable set  
For standard motor

Model	Length [m (ft.)]
CC010VPR	1 (3.3)
CC020VPR	2 (6.6)
CC030VPR	3 (9.8)
CC050VPR	5 (16.4)
CC070VPR	7 (23.0)
CC100VPR	10 (32.8)
CC150VPR	15 (49.2)

• Flexible extension cable set  
For electromagnetic brake motor

Model	Length [m (ft.)]
CC010VPRBT	1 (3.3)
CC020VPRBT	2 (6.6)
CC030VPRBT	3 (9.8)
CC050VPRBT	5 (16.4)
CC070VPRBT	7 (23.0)
CC100VPRBT	10 (32.8)
CC150VPRBT	15 (49.2)

■ Driver cable

This cable is a shielded cable for the driver control I/O that has good noise immunity. The ground wires useful to grounding are provided at both ends of the cable.

Model	Length [m (ft.)]
CC16D1B-1	1 (3.3)
CC16D2B-1	2 (6.6)

■ Pulse signal converter for noise immunity

This product is used to eliminate the noise of the pulse signal and convert the pulse signal to the line driver type.

Model: **VCS06**

■ CR circuit for surge suppression

This product is effective to suppress the surge which occurs in a relay contact part. Use it to protect the contacts of the relay or switch.

Model: **EPCR1201-2**

## ■ CR circuit module

This product is effective to suppress the surge which occurs in a relay contact part. Use this product to protect the contacts of the relay or switch.

4 pieces of CR circuit for surge suppression are mounted on the compact circuit, and this product can be installed to the DIN rail. This product can make the wiring easily and securely since it also supports terminal block connection.

Model: **VCS02**





- Unauthorized reproduction or copying of all or part of this Operating Manual is prohibited.  
If a new copy is required to replace an original manual that has been damaged or lost, please contact your nearest Oriental Motor branch or sales office.
- Oriental Motor shall not be liable whatsoever for any problems relating to industrial property rights arising from use of any information, circuit, equipment or device provided or referenced in this manual.
- Characteristics, specifications and dimensions are subject to change without notice.
- While we make every effort to offer accurate information in the manual, we welcome your input. Should you find unclear descriptions, errors or omissions, please contact the nearest office.
- **Orientalmotor** is registered trademark or trademark of Oriental Motor Co., Ltd., in Japan and other countries.  
Other product names and company names mentioned in this manual may be registered trademarks or trademarks of their respective companies and are hereby acknowledged. The third-party products mentioned in this manual are recommended products, and references to their names shall not be construed as any form of performance guarantee. Oriental Motor is not liable whatsoever for the performance of these third-party products.

© Copyright ORIENTAL MOTOR CO., LTD. 2013

- Please contact your nearest Oriental Motor office for further information.

ORIENTAL MOTOR U.S.A. CORP.  
Technical Support Tel:(800)468-3982  
8:30 A.M. to 5:00 P.M., P.S.T. (M-F)  
7:30 A.M. to 5:00 P.M., C.S.T. (M-F)  
www.orientalmotor.com

ORIENTAL MOTOR DO BRASIL LTDA.  
Tel:+55-11-3266-6018  
www.orientalmotor.com.br

ORIENTAL MOTOR (EUROPA) GmbH  
Schiessstraße 74, 40549 Düsseldorf, Germany  
Technical Support Tel:00 800/22 55 66 22  
www.orientalmotor.de

ORIENTAL MOTOR (UK) LTD.  
Tel:01256-347090  
www.orientalmotor.co.uk

ORIENTAL MOTOR (FRANCE) SARL  
Tel:01 47 86 97 50  
www.orientalmotor.fr

ORIENTAL MOTOR ITALIA s.r.l.  
Tel:02-93906346  
www.orientalmotor.it

ORIENTAL MOTOR ASIA PACIFIC PTE. LTD.  
Singapore  
Tel:1800-8420280  
www.orientalmotor.com.sg

ORIENTAL MOTOR (MALAYSIA) SDN. BHD.  
Tel:1800-806161  
www.orientalmotor.com.my

ORIENTAL MOTOR (THAILAND) CO., LTD.  
Tel:1800-888-881  
www.orientalmotor.co.th

ORIENTAL MOTOR (INDIA) PVT. LTD.  
Tel:+91-80-41125586  
www.orientalmotor.co.in

TAIWAN ORIENTAL MOTOR CO., LTD.  
Tel:0800-060708  
www.orientalmotor.com.tw

SHANGHAI ORIENTAL MOTOR CO., LTD.  
Tel:400-820-6516  
www.orientalmotor.com.cn

INA ORIENTAL MOTOR CO., LTD.  
Korea  
Tel:080-777-2042  
www.inaom.co.kr

ORIENTAL MOTOR CO., LTD.  
Hong Kong Branch  
Tel:+852-2427-9800

ORIENTAL MOTOR CO., LTD.  
4-8-1 Higashiueno, Taito-ku, Tokyo  
110-8536 Japan  
Tel:03-6744-0361  
www.orientalmotor.co.jp