



Stepping Motor and Driver Package

αSTEP

AR Series/

Motorized actuator equipped with AR Series

AC power input/DC power input Pulse Input Type

USER MANUAL

- AC power input type



KCC-REM-OMC-025
KCC-REM-OMC-026
KCC-REM-OMC-027

- DC power input type



KCC-REM-OMC-031
MSIP-REM-OMC-079

Introduction

AC power input type

DC power input type

AC power input type/
DC power input type
Common

Appendix

Thank you for purchasing an Oriental Motor product.

This Operating Manual describes product handling procedures and safety precautions.

- Please read it thoroughly to ensure safe operation.
- Always keep the manual where it is readily available.

1 Introduction

1	Before use	8
2	Operating Manuals for the AR Series	9
3	Overview of the product.....	10
4	Safety precautions	11
4-1	Safety precautions.....	11
4-2	Graphical symbols on the driver's front panel	13
4-3	Warning sign (AC power input)	13
5	Precautions for use	14

2 AC power input type

1	System configuration	18
2	Preparation.....	19
2-1	Checking the product	19
2-2	How to identify the product model	20
2-3	Information about nameplate	21
2-4	Combinations of motors and drivers.....	21
2-5	Input/output power ratings.....	23
2-6	Names and functions of parts	23
3	Installation.....	26
3-1	Location for installation.....	26
3-2	Installing the motor	26
3-3	Installing a load	27
3-4	Permissible radial load and permissible axial load	28
3-5	Installing the driver	31
3-6	Installing the regeneration resistor.....	32
4	Connection	33
4-1	Connection example	33
4-2	Connecting the I/O signals.....	35
4-3	Connecting the power supply	43
4-4	Grounding the motor and driver	44
4-5	Connecting the 24 VDC power supply, regeneration resistor and electromagnetic brake	44
4-6	Connecting the data setter	46
4-7	Noise measures	47
4-8	Installing and wiring in compliance with EMC Directive.....	48
5	Guidance	50
6	Setting	52
6-1	Resolution.....	52
6-2	Pulse input mode.....	53
6-3	Operating current	53
6-4	Speed filter	54

7	Accessories	55
7-1	Motor cable set.....	55
7-2	Setting tool	57
7-3	Wiring support tool.....	57

3 DC power input type

1	System configuration	60
2	Preparation.....	61
2-1	Checking the product	61
2-2	How to identify the product model	62
2-3	Information about nameplate	63
2-4	Combinations of motors and drivers.....	63
2-5	Input/output power ratings.....	65
2-6	Names and functions of parts	65
3	Installation.....	68
3-1	Location for installation.....	68
3-2	Installing the motor	68
3-3	Installing a load	69
3-4	Permissible radial load and permissible axial load	70
3-5	Installing the driver	72
4	Connection	74
4-1	Connection example	74
4-2	Connecting the I/O signals.....	75
4-3	Connecting the power supply and grounding the driver.....	82
4-4	Grounding the motor	83
4-5	Connecting the data setter	83
4-6	Noise measures	83
4-7	Conformity to the EMC Directive	85
5	Guidance.....	86
6	Setting	88
6-1	Resolution.....	88
6-2	Pulse input mode.....	88
6-3	Operating current	89
6-4	Speed filter	89
7	Accessories	91
7-1	Motor cable set.....	91
7-2	Setting tool	93
7-3	Wiring support tool.....	93

4 AC power input type/DC power input type Common

1	Explanation of I/O signals.....	96
1-1	Input signals	96
1-2	Output signals.....	100
2	Parameter list	104
2-1	Application parameters.....	104
2-2	System parameters.....	106
3	Setting using the data setter	107
3-1	Resolution.....	107
3-2	Pulse input mode.....	109
3-3	Motor excitation at power ON	111
3-4	Automatic return operation.....	111
3-5	Motor rotation direction	112
3-6	Positioning completion signal offset.....	112
4	Operation using a data setter	113
4-1	Before operation	113
4-2	Push-motion operation	114
4-3	Test operation	117
4-4	Return to electrical home operation	119
5	Adjustment using the data setter	122
5-1	Control mode	122
5-2	Operating current.....	122
5-3	Standstill current.....	123
5-4	Speed filter	123
5-5	Smooth drive.....	124
5-6	Speed error gain.....	124
5-7	Position loop gain, speed loop gain, speed loop integral time constant.....	125
5-8	Anti-vibration control.....	125
6	Operation using the OPX-2A.....	126
6-1	Overview of the OPX-2A	126
6-2	Names and functions of parts.....	127
6-3	How to read the display	127
6-4	OPX-2A error display	128
6-5	Screen transitions	129
6-6	Monitor mode	136
6-7	Parameter mode.....	137
6-8	Test mode	138
6-9	Copy mode.....	139
7	Inspection and maintenance	141
7-1	Inspection.....	141
7-2	Warranty.....	141
7-3	Disposal	141

8	Alarms and warnings.....	142
8-1	Alarms	142
8-2	Warnings.....	146
9	Troubleshooting and remedial actions.....	148

5 Appendix

1	Timing charts	152
2	Specifications	163
3	General specifications	164
3-1	AC power input.....	164
3-2	DC power input	165
4	Regulations and standards.....	166
4-1	UL Standards	166
4-2	EU Directives.....	166
4-3	Republic of Korea, Radio Waves Act.....	167
4-4	RoHS Directive	167

1 Introduction



This part explains the product overview and safety precautions in addition to the types and descriptions about operating manuals.

◆ Table of contents

1	Before use	8
2	Operating Manuals for the AR Series ..	9
3	Overview of the product.....	10
4	Safety precautions	11
4-1	Safety precautions.....	11
4-2	Graphical symbols on the driver's front panel.....	13
4-3	Warning sign (AC power input)	13
5	Precautions for use.....	14

1 Before use

Only qualified personnel should work with the product.

Use the product correctly after thoroughly reading the section "4 Safety precautions" on p.11. In addition, be sure to observe the contents described in warning, caution, and note in this manual.

The product described in this manual has been designed and manufactured to be incorporated in general industrial equipment. Do not use for any other purpose. Oriental Motor Co., Ltd. is not responsible for any damage caused through failure to observe this warning.

2 Operating Manuals for the AR Series

Operating manuals for the **AR** Series are listed below.
After reading the manuals, keep them in a convenient place where it is readily available.

Type and description of operating manuals

Read these manuals first

AR Series AC power input/DC power input

- OPERATING MANUAL Motor (supplied with the motor) These manuals explain functions, installation methods and others.
- OPERATING MANUAL Pulse input type Driver (supplied with the driver)

AR Series AC power input/DC power input Pulse input type

- USER MANUAL (this document)

This manual explains operating methods of the **OPX-2A** and troubleshooting in addition to functions and installation/connection methods about the motor and driver, data setting methods, and operating methods.

APPENDIX UL Standards for AR Series (supplied with the product)

This appendix includes information required for certification of the UL Standards.

Motorized actuator

- OPERATING MANUAL Actuator (supplied with the actuator)
- Function Setting Edition

The Actuator Edition explains installation methods and maintenance for motorized actuators.
The Function Setting Edition explains settings of parameters required for when an actuator is combined with a driver.

■ About terms and units

Terms and units to be used vary depending on a motor or motorized actuator. This manual explains by using the terms of the motor.

When the motorized actuator is used, read this manual by replacing the terms.

	Motor	Motorized actuator
Term	Torque	Thrust force
	Moment of inertia	Mass
	Rotation	Movement
	CW direction	FWD direction
	CCW direction	RVS direction
	Rotation speed	Speed
	Resolution	Minimum travel amount
Unit	N·m	N
	kHz/s	m/s ²

3 Overview of the product

This product is a stepping motor and driver package consisting of a stepping motor with a built-in rotor position detection sensor and a high-performance microstep driver.

When the **AR Series** is used with the support software **MEXE02** or accessory data setter **OPX-2A**, push-motion operation can be performed in addition to accurate positioning operation.

■ Main features

● Introducing closed loop control

The **AR Series** can continue its operation even upon encountering quick acceleration or an abrupt change in load. Monitoring the speed and amount of rotation while the motor is running, the **AR Series** performs closed-loop control under overload and similar conditions to continue its operation at the peak torque.

● Energy-saving

Motor and driver losses have been substantially reduced to achieve low heat generation and save energy. Since the motor and driver generate much less heat, they can now be operated for longer hours at high speed, which was not possible with conventional stepping motors/drivers.

● Easy adjustment using a speed filter

Even after the motor has been installed in the equipment, the motor response can be adjusted to suppress vibration using a digital switch with ease.

● Separate main power supply and control power supply (AC power input)

A separate 24 VDC power supply is connected to supply control power, independently of the main power supply. This way, the motor position can be detected and contents of alarms can be checked while the 24 VDC power is supplied, even when the main power is cut off.

● Supporting sink output and source output

The driver supports both the current sink output circuit and the current source output circuit. (Line driver output is not supported).

● Automatically controlled electromagnetic brake

Since the driver automatically controls the electromagnetic brake, all you need to do is connect a 24 VDC power supply to operate the electromagnetic brake. This saves time to adjust the timings of control signal inputs and design a ladder program.

● Alarm and warning functions

The driver provides alarms that are designed to protect the driver from overheating, poor connection, error in operation, etc. (protective functions), as well as warnings that are output before the corresponding alarms generate (warning functions).

■ Various operation modes

Positioning operation and return-to-electrical home operation can be performed. Push-motion operation can also be performed if the **MEXE02** or the **OPX-2A** is used.



■ Extended functions

When used with the **MEXE02** or the **OPX-2A**, the desired parameters, operation mode, resolution and other items can be set according to your equipment.

4 Safety precautions

4-1 Safety precautions

The precautions described below are intended to prevent danger or injury to the user and other personnel through safe, correct use of the product. Use the product only after carefully reading and fully understanding these instructions.

 WARNING	Handling the product without observing the instructions that accompany a "Warning" symbol may result in serious injury or death.
 CAUTION	Handling the product without observing the instructions that accompany a "Caution" symbol may result in injury or property damage.
 Note	The items under this heading contain important handling instructions that the user should observe to ensure safe use of the product.

WARNING

■ AC power input/DC power input common

General

- Do not use the product in explosive or corrosive environments, in the presence of flammable gases, locations subjected to splashing water, or near combustibles. Doing so may result in fire, electric shock or injury.
- Assign qualified personnel the task of installing, wiring, operating/controlling, inspecting and troubleshooting the product. Failure to do so may result in fire, electric shock, injury or damage to equipment.
- Do not transport, install the product, perform connections or inspections when the power is on. Always turn the power off before carrying out these operations. Failure to do so may result in electric shock.
- Provide means to hold the moving parts in place for vertical drive such as elevating equipment. The motor loses holding torque when the power is shut off, allowing the moving parts to fall and possibly cause injury or damage to equipment.
- The brake mechanism of an electromagnetic brake motor is used to keep the moving part and motor in position. Do not use it as a deceleration/safety brake. Doing so may result in injury or damage to the equipment.
- When the driver generates an alarm (any of the driver's protective functions is triggered), the motor will stop and lose its holding torque. Accordingly, provide measures to hold the moving part in place in the event of an alarm. Failure to do so may result in injury or equipment damage.
- When the driver generates an alarm (any of the driver's protective functions is triggered), first remove the cause and then clear the protection function. Continuing the operation without removing the cause of the problem may cause malfunction of the motor and driver, leading to injury or damage to equipment.

Installation

- Install the motor and driver in the enclosure in order to prevent electric shock or injury.

Connection

- Keep the driver's input power voltage within the specified range. Failure to do so may result in fire or electric shock.
- Connect the cables securely according to the wiring diagram. Failure to do so may result in fire or electric shock.
- Do not forcibly bend, pull or pinch the cable. Doing so may fire and electric shock.

Operation

- Turn off the driver power in the event of a power failure. Or the motor may suddenly start when the power is restored and may cause injury or damage to equipment.
- Do not turn the FREE input to ON while the motor is operating. The motor will stop and lose its holding power. Doing so may result in injury or damage to equipment.

Repair, disassembly and modification

- Do not disassemble or modify the motor and driver. This may cause electric shock or injury. Refer all such internal inspections and repairs to the branch or sales office from which you purchased the product.

■ AC power input

Installation

- The motor and driver are designed with Class I equipment basic insulation. When installing the motor and driver, install them inside enclosures so that they are out of the direct reach of users. Be sure to ground if users can touch them. Failure to do so may result in electric shock.

Maintenance and inspection

- Do not touch the connection terminals on the driver while the power is supplied or for at least 10 minutes after turning off the power. Before making wiring connections or carrying out checks, also wait for the CHARGE LED to turn off and check the voltage with a tester, etc. Failure to do so may result in electric shock.

■ DC power input

Installation

- When installing the motor and driver, do not touch the driver without grounding the driver first. Doing so may result in electric shock.

Connection

- For the driver's power supply, use a DC power supply with reinforced insulation on its primary and secondary sides. Failure to do so may result in electric shock.



■ AC power input/DC power input common

General

- Do not use the motor and driver beyond its specifications. Doing so may result in electric shock, injury or damage to equipment.
- Keep your fingers and objects out of the openings in the motor and driver. Failure to do so may result in fire, electric shock or injury.
- Do not touch the motor and driver during operation or immediately after stopping. The surface is hot and may cause a skin burn(s).

Transportation

- Do not carry the motor by holding the motor output shaft or motor cable. Doing so may cause injury.

Installation

- Provide a cover over the rotating parts (output shaft) of the motor. Failure to do so may result in injury.
- Do not leave anything around the motor and driver that would obstruct ventilation. Doing so may result in damage to equipment.

Operation

- Use a motor and driver only in the specified combination. An incorrect combination may cause a fire.
- Provide an emergency stop device or emergency stop circuit external to the equipment so that the entire equipment will operate safely in the event of a system failure or malfunction. Failure to do so may result in injury.
- Before supplying power to the driver, turn all input signals to the driver OFF. Otherwise, the motor may start suddenly at power ON and cause injury or damage to equipment.
- Do not touch the rotating part (output shaft) during operation. Doing so may cause injury.
- The motor surface temperature may exceed 70 °C (158 °F) even under normal operating conditions. If the operator is allowed to approach the running motor, attach a warning label as shown below in a conspicuous position. Failure to do so may result in skin burn(s).
- Before moving the motor directly with the hands, confirm that the FREE input turns ON. Failure to do so may result in injury.
- Immediately when trouble has occurred, stop running and turn off the driver power. Failure to do so may result in fire, electric shock or injury.
- To prevent electric shock, use only an insulated screwdriver to adjust the driver's switches.



Warning label

Maintenance and inspection

- When the insulation resistance measurement or dielectric strength test is conducted, do not touch the terminals. Doing so may result in electric shock.

■ AC power input

Connection

- The data edit connector (CN4) and I/O signal connector (CN5) are not insulated. When grounding the positive terminal of the power supply, do not connect any equipment (PC, etc.) whose negative terminal is grounded. Doing so may cause the driver and these equipment to short, damaging both.

Operation



- Use a 24 VDC power supply that has been given reinforced insulation between the primary side and secondary side. Failure to do so may cause electric shock.

■ DC power input

Connection

- The power supply connector (CN1), data edit connector (CN4) and I/O signal connector (CN5) are not insulated. When grounding the positive terminal of the power supply, do not connect any equipment (PC, etc.) whose negative terminal is grounded. Doing so may cause the driver and these equipment to short, damaging both.

4-2 Graphical symbols on the driver's front panel

	⚠ WARNING This is the Protective Earth Terminal. Be sure to ground because improper grounding may result in electric shock.
	⚠ WARNING A high voltage is applied to the motor connector (CN2) and the main power supply input terminal (CN3). Do not touch these terminals while the power is on. Doing so may result in fire or electric shock. (AC power input)

4-3 Warning sign (AC power input)

A warning about handling precautions is described on the AC power input driver. Be sure to observe the description contents when handling the driver.

Electrical hazard warning label

⚠ WARNING – Risk of electric shock.	
⚠	• Read manual before installing. (Multiple rated) • Do not touch the driver immediately after the power is cut off, or until the CHARGE LED (lit in red) turns off. Doing so may result in electric shock due to residual voltage.
⚠ AVERTISSEMENT – Risque de décharge électrique.	
⚠	• Lire le manuel avant l'installation. • Ne pas toucher au variateur immédiatement après la mise hors tension ou avant que la LED "présence de la tension" (Rouge) ne soit éteinte. Le non respect de ces règles pourrait entraîner un choc électrique.
⚠ 警告 – けが・感電のおそれがあります。	
⚠	• 据え付け、運転の前には必ず取扱説明書をお読み下さい。 • 電源を切った直後、CHARGE LED (赤色点灯) が消灯するまでドライバに触れないで下さい。残留電圧により感電の原因になります。

Material: PET

5 Precautions for use

This section covers limitations and requirements the user should consider when using the product.

■ AC power input/DC power input common

● Always use the cable (supplied or accessory) to connect the motor and driver.

Be sure to use the cable (supplied or accessory) to connect the motor and driver.

In the following condition, an appropriate accessory cable must be purchased separately. For details, refer to p.55 (AC power input), p.91 (DC power input).

- If a flexible cable is to be used.
- If a cable of 3 m (9.8 ft.) or longer is to be used.
- If a motor and driver package without a cable was purchased.



Precautions for when the connection cable is used are described on p.16. Be sure to read before use.

● When conducting the insulation resistance measurement and the dielectric strength test, be sure to separate the connection between the motor and the driver.

Conducting the insulation resistance measurement or dielectric strength test with the motor and driver connected may result in damage to equipment.

● Do not apply a radial load and axial load in excess of the specified permissible limit.

Operating the motor under an excessive radial load or axial load may damage the motor bearings (ball bearings). Be sure to operate the motor within the specified permissible limit of radial load and axial load. For details, refer to p.28 (AC power input), p.70 (DC power input).

● Use the motor in conditions where its surface temperature will not exceed 100 °C (212 °F).

The driver has an overheat protection function, but the motor has no such feature. The motor surface temperature may exceed 100 °C (212 °F) under certain conditions (ambient temperature, operating speed, duty cycle, etc.). To prevent the motor bearings (ball bearings) from reaching its usable life quickly, use the motor in conditions where the surface temperature will not exceed 100 °C (212 °F).

Use the geared type motor in a condition where the gear case temperature does not exceed 70 °C (158 °F), in order to prevent deterioration of grease and parts in the gear case.

If the motor is to be operated continuously, install the motor in a location where heat dissipation capacity equivalent to a level achieved with a heat sink [made of aluminum, 250×250×6 mm (9.84×9.84×0.24 in.)] is ensured.

● Holding torque at standstill

The motor holding torque is reduced by the current cutback function of the driver at motor standstill. When selecting a motor, check the holding torque at motor standstill in the specifications on the catalog.

● Do not use the electromagnetic brake to reduce speed or as a safety brake.

Do not use the electromagnetic brake as a means to decelerate and stop the motor. The brake hub of the electromagnetic brake will wear significantly and the braking force will drop. Since the power off activated type electromagnetic brake is equipped, it helps maintain the position of the load when the power is cut off, but this brake cannot securely hold the load in place. Accordingly, do not use the electromagnetic brake as a safety brake. To use the electromagnetic brake to hold the load in place, do so after the motor has stopped.

● Double shaft type motor

Do not apply a load torque, radial load or axial load to the output shaft on the opposite side of the motor output shaft.

● Preventing electrical noise

For measures with regard to noise, refer to p.47 (AC power input), p.83 (DC power input).

● Peak torque of geared type motor

Always operate the geared type motor under a load not exceeding the peak torque. If the load exceeds the peak torque, the gear will be damaged.

● Motor excitation at power ON

Simply turning on the power will not excite the motor. To excite the motor, always turn the C-ON input ON. If the applicable driver parameter is changed using the **MEXE02** or **OPX-2A**, the motor can be excited automatically after the power ON.

● **Rotating direction of output shaft**

The motor output shaft rotates as shown in the figure for the parameters of the factory setting.

- When inputting pulse signals of the CW input in the 2-pulse input mode
- When turning the DIR input ON in the 1-pulse input mode
- When inputting pulse signals of the CCW input in the 2-pulse input mode
- When turning the DIR input OFF in the 1-pulse input mode

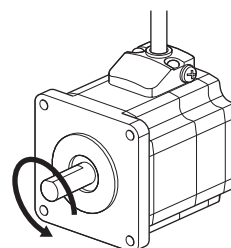
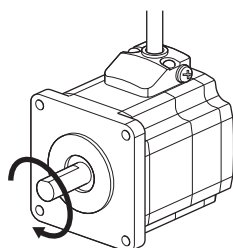

The relationship between the rotating direction of the motor shaft and that of the gear output shaft changes as follows, depending on the gear type and gear ratio. Check with the following table.

Type of gear	Gear ratio	Rotating direction (relative to the motor rotating direction)
TH geared	3.6, 7.2, 10	Same direction
	20, 30	Opposite direction
PL geared, PS geared, PN geared, FC geared	All gear ratios	Same direction
Harmonic geared	All gear ratios	Opposite direction

● **About grease of geared motor**

On rare occasions, a small amount of grease may ooze out from the geared motor. If there is concern over possible environmental damage resulting from the leakage of grease, check for grease stains during regular inspections. Alternatively, install an oil pan or other device to prevent leakage from causing further damage. Oil leakage may lead to problems in the customer's equipment or products.

● **Do not perform push-motion operation with geared motors.**

Doing so may result in damage to the motor or gear part.

● **Saving data to the non-volatile memory**

Do not turn off the main power supply or 24 VDC power supply while data is being written to the non-volatile memory and 5 seconds after the completion of data write. Doing so may abort the data write and cause an EEPROM error alarm to generate. The non-volatile memory can be rewritten approximately 100,000 times.

■ **AC power input**

● **Preventing leakage current**

Stray capacitance exists between the driver's current-carrying line and other current-carrying lines, the earth and the motor, respectively. A high-frequency current may leak out through such capacitance, having a detrimental effect on the surrounding equipment. The actual leakage current depends on the driver's switching frequency, the length of wiring between the driver and motor, and so on. When providing a leakage current breaker, use the following products, for example, which have high-frequency signal protection:
Mitsubishi Electric Corporation: NV series

● **When an alarm of overvoltage protection is generated**

If vertical drive (gravitational operation) such as elevator applications is performed or if sudden start-stop operation of a large inertial load is repeated frequently, an alarm of overvoltage protection may be detected. If an overvoltage protection alarm is detected, adjust the driving condition or use the accessory regeneration resistor.

● **Note on connecting a power supply whose positive terminal is grounded**

The data edit connector (CN4) and I/O signal connector (CN5) are not insulated. When grounding the positive terminal of the power supply, do not connect any equipment (PC, etc.) whose negative terminal is grounded. Doing so may cause the driver and these equipment to short, damaging both. Use the data setter **OPX-2A** to set data, etc.

■ DC power input

● When an alarm of overvoltage protection is generated

If vertical drive (gravitational operation) such as elevator applications is performed or if sudden start-stop operation of a large inertial load is repeated frequently, an alarm of overvoltage protection may be detected. If an overvoltage protection alarm is detected, adjust the driving condition.

● Note on connecting a power supply whose positive terminal is grounded

The power supply connector (CN1), data edit connector (CN4) and I/O signal connector (CN5) are not insulated. When grounding the positive terminal of the power supply, do not connect any equipment (PC, etc.) whose negative terminal is grounded. Doing so may cause the driver and these equipment to short, damaging both. Use the data setter **OPX-2A** to set data, etc.

■ Notes for when the connection cable is used

Note the following points when a supplied cable or an accessory cable is used.

● When inserting the connector

Hold the connector main body, and insert it in straight securely. Inserting the connector in a inclined state may result in damage to terminals or a connection failure.

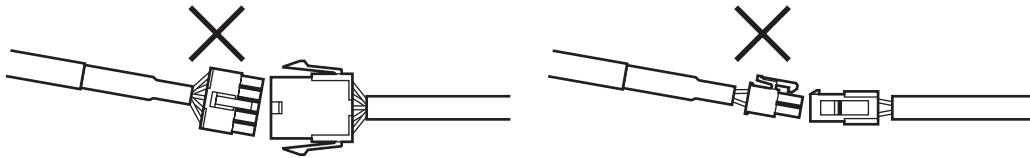

● When pulling out the connector

Pull out the connector in straight while releasing the lock part of the connector. Pulling out the connector with holding the cable (lead wire) may result in damage to the connector.

● Bending radius of cable

Use the cable in a state where the bending radius of the cable is more than 6 times of the cable diameter. In the case of the lead wire type, use in a state where the bending radius is more than 4 times of the diameter of the lead wires.

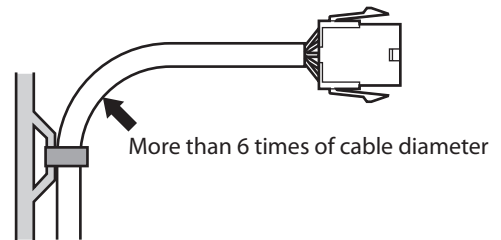

● How to fix the cable

Fix the cable at the positions near the connector so as to apply no stress on the connector part. Take measures so as to apply no stress on the connector by using wide clamps or by fixing at two places.

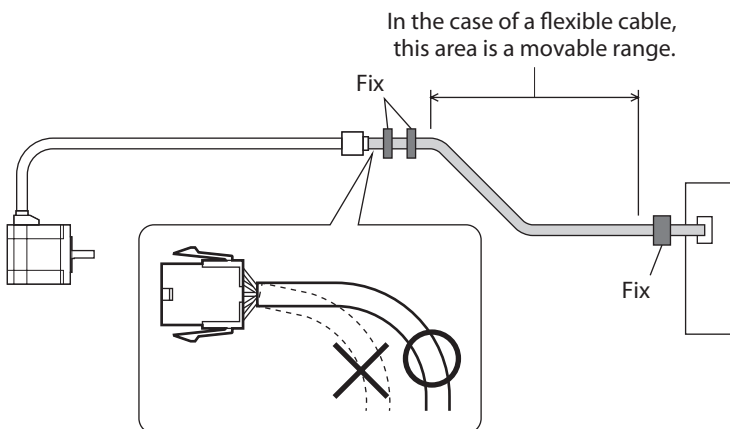

2 AC power input type

This part explains contents specific to the AR Series AC power input type.

◆Table of contents

1	System configuration.....	18		
2	Preparation	19		
	2-1 Checking the product	19		
	2-2 How to identify the product model	20		
	2-3 Information about nameplate	21		
	2-4 Combinations of motors and drivers.....	21		
	2-5 Input/output power ratings.....	23		
	2-6 Names and functions of parts.....	23		
3	Installation	26		
	3-1 Location for installation.....	26		
	3-2 Installing the motor	26		
	3-3 Installing a load	27		
	3-4 Permissible radial load and permissible axial load.....	28		
	3-5 Installing the driver.....	31		
	3-6 Installing the regeneration resistor.....	32		
4	Connection	33		
	4-1 Connection example	33		
	4-2 Connecting the I/O signals.....	35		
	4-3 Connecting the power supply	43		
	4-4 Grounding the motor and driver	44		
	4-5 Connecting the 24 VDC power supply, regeneration resistor and electromagnetic brake.....	44		
	4-6 Connecting the data setter	46		
	4-7 Noise measures	47		
	4-8 Installing and wiring in compliance with EMC Directive.....	48		
5	Guidance	50		
6	Setting	52		
	6-1 Resolution	52		
	6-2 Pulse input mode.....	53		
	6-3 Operating current.....	53		
	6-4 Speed filter.....	54		
7	Accessories.....	55		
	7-1 Motor cable set.....	55		
	7-2 Setting tool	57		
	7-3 Wiring support tool.....	57		

1 System configuration

With the **AR** Series pulse input type, all you need to do in order to operate the motor is to turn the C-ON input ON and input pulses.

2 AC power input type

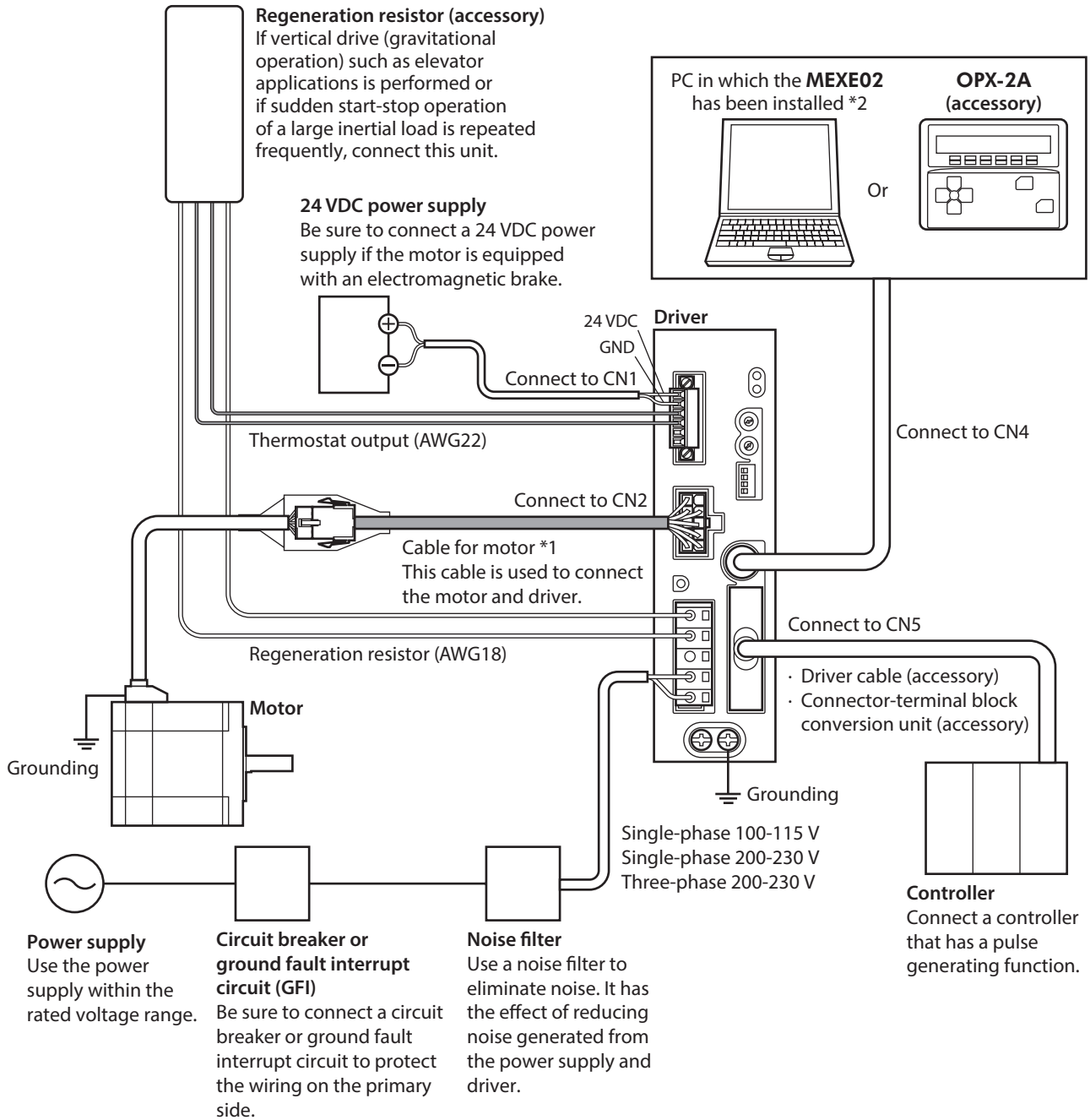

*1 Cables represented in gray color are supplied with the product or sold separately.

*2 The PC must be supplied by the user. Use the accessory communication cable for the support software when connecting the PC and driver.

2 Preparation

This chapter explains the items you should check, as well as the name and function of each part.

2-1 Checking the product

Verify that the items listed below are included. Report any missing or damaged items to the Oriental Motor sales office from which you purchased the product.

Verify the model number of the purchased unit against the number shown on the package label.

Check the model number of the motor and driver against the number shown on the nameplate. Refer to p.21 for how to identify the nameplate.

The motor and driver package names and corresponding motor/driver combinations are listed on p.21.

- Motor 1 unit
- Driver 1 unit
- CN1 connector (6 pins)..... 1 pc.
- CN3 connector (5 pins)..... 1 pc.
- CN5 connector (36 pins) 1 pc.
- Connector wiring lever (for CN3)..... 1 pc.
- OPERATING MANUAL Motor..... 1 copy
- OPERATING MANUAL Driver..... 1 copy
- APPENDIX UL Standards for **AR** Series..... 1 copy
- Cable for motor 1 pc. *1
- Cable for electromagnetic brake 1 pc. *1 *2
- Parallel key 1 pc. *3

*1 When the product is supplied with a connection cable.

*2 Supplied with electromagnetic brake type.

*3 Supplied with geared types; except for the **AR46TH**, **AR46PL** and **AR66TH**.

Supplied connector model

Type	Model number	Manufacturer
CN1 connector	MC1,5/6-STF-3,5	PHOENIX CONTACT GmbH & Co. KG
CN3 connector	54928-0570	Molex
CN5 connector	Case: 10336-52A0-008	3M Japan Limited
	Connector: 10136-3000PE	3M Japan Limited

2-2 How to identify the product model

- Standard type

AR 6 6 A A -1
 1 2 3 4 5 9

- Geared type

AR 6 6 A A - H 50 -2
 1 2 3 4 5 6 7 9

- FC geared type

AR 6 6 A A - FC 10 LA -3
 1 2 3 4 5 6 7 8 9

1	Series name	AR Series
2	Motor frame size	4 : 42 mm (1.65 in.) 6 : 60 mm (2.36 in.) 9 : 85 mm (3.35 in.) [90 mm (3.54 in.) for geared type]
3	Motor length	
4	Motor type	A : Single shaft B : Double shaft M : With electromagnetic brake
5	Power supply voltage	A : Single-phase 100-115 V C : Single-phase 200-230 V S : Three-phase 200-230 V
6	Type of gear	T : TH geared type FC : FC geared type P : PL geared type PS : PS geared type N : PN geared type H : Harmonic geared type Blank: Standard type
7	Gear ratio	Indicates a number representing the gear ratio. Refer to the table below for the gear type and gear ratio.
8	Output shaft direction	LA : L axis (left side) RA : R axis (right side)
9	Length of connection cable	Number: Length of supplied connection cable (m) Blank: Without connection cable

Type of gear ratio

Type of gear	Gear ratio
TH geared type	3.6, 7.2, 10, 20, 30
FC geared type	7.2, 10, 20, 30
PL geared type	5, 7.2, 10, 25, 36, 50
PS geared type	5, 7.2 (*), 10, 25, 36, 50
PN geared type	AR46 : 5, 7.2, 10 AR66, AR98 : 5, 7.2, 10, 25, 36, 50
Harmonic geared type	50, 100

* The model name is "7" for the gear ratio 7.2 of the **PS** geared type.

2-3 Information about nameplate

The figure shows an example.

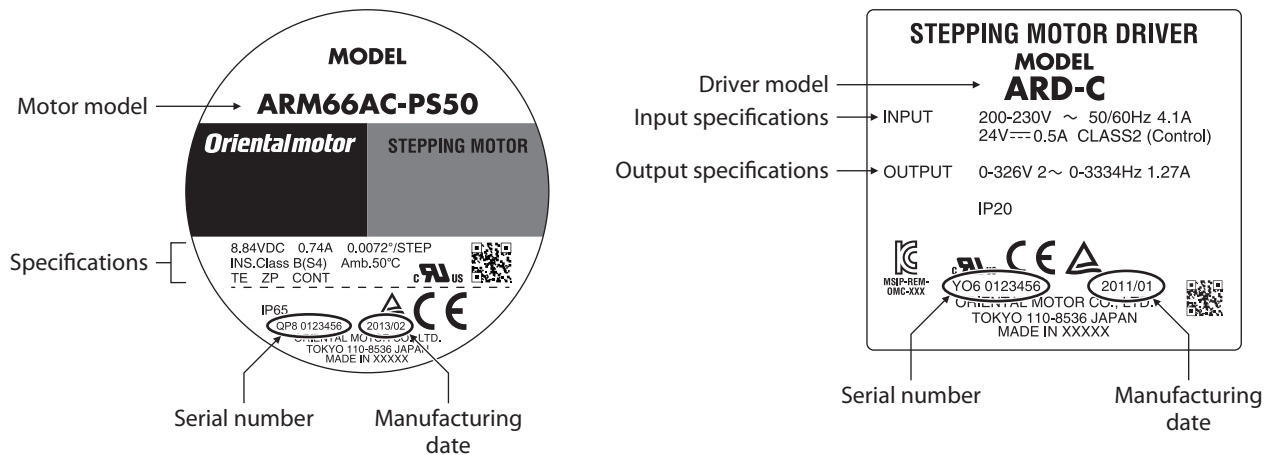

memo The position describing the information may vary depending on the product.

2-4 Combinations of motors and drivers

- ◆ in the model names represents **A** (single-phase 100-115 V), **C** (single-phase 200-230 V) or **S** (three-phase 200-230 V) indicating the power supply input.
- in the model names represents a number indicating the gear ratio.
- in the model names represents the cable length (-1, -2, -3) when the connection cable is supplied.

Standard type

● Single shaft

Model	Motor model	Driver model
AR46A◆□	ARM46AC	ARD-◆
AR66A◆□	ARM66AC	
AR69A◆□	ARM69AC	
AR98A◆□	ARM98AC	
AR911A◆□	ARM911AC	

● Double shaft

Model	Motor model	Driver model
AR46B◆□	ARM46BC	ARD-◆
AR66B◆□	ARM66BC	
AR69B◆□	ARM69BC	
AR98B◆□	ARM98BC	
AR911B◆□	ARM911BC	

● With electromagnetic brake

Model	Motor model	Driver model
AR46M◆□	ARM46MC	ARD-◆
AR66M◆□	ARM66MC	
AR69M◆□	ARM69MC	
AR98M◆□	ARM98MC	

TH geared type

● Single shaft

Model	Motor model	Driver model
AR46A◆-T■□	ARM46AC-T■	ARD-◆
AR66A◆-T■□	ARM66AC-T■	
AR98A◆-T■□	ARM98AC-T■	

● With electromagnetic brake

Model	Motor model	Driver model
AR46M◆-T■□	ARM46MC-T■	ARD-◆
AR66M◆-T■□	ARM66MC-T■	
AR98M◆-T■□	ARM98MC-T■	

■ FC geared type

● Single shaft

Model	Motor model	Driver model
AR46A◆-FC■LA□	ARM46AC-FC■LA	ARD-◆
AR46A◆-FC■RA□	ARM46AC-FC■RA	
AR66A◆-FC■LA□	ARM66AC-FC■LA	
AR66A◆-FC■RA□	ARM66AC-FC■RA	

■ PL geared type

● Single shaft

Model	Motor model	Driver model
AR46A◆-P■□	ARM46AC-P■	ARD-◆
AR66A◆-P■□	ARM66AC-P■	
AR98A◆-P■□	ARM98AC-P■	

● With electromagnetic brake

Model	Motor model	Driver model
AR46M◆-P■□	ARM46MC-P■	ARD-◆
AR66M◆-P■□	ARM66MC-P■	
AR98M◆-P■□	ARM98MC-P■	

■ PS geared type

● Single shaft

Model	Motor model	Driver model
AR46A◆-PS■□	ARM46AC-PS■	ARD-◆
AR66A◆-PS■□	ARM66AC-PS■	
AR98A◆-PS■□	ARM98AC-PS■	

● With electromagnetic brake

Model	Motor model	Driver model
AR46M◆-PS■□	ARM46MC-PS■	ARD-◆
AR66M◆-PS■□	ARM66MC-PS■	
AR98M◆-PS■□	ARM98MC-PS■	

■ PN geared type

● Single shaft

Model	Motor model	Driver model
AR46A◆-N■□	ARM46AC-N■	ARD-◆
AR66A◆-N■□	ARM66AC-N■	
AR98A◆-N■□	ARM98AC-N■	

● With electromagnetic brake

Model	Motor model	Driver model
AR46M◆-N■□	ARM46MC-N■	ARD-◆
AR66M◆-N■□	ARM66MC-N■	
AR98M◆-N■□	ARM98MC-N■	

■ Harmonic geared type

● Single shaft

Model	Motor model	Driver model
AR46A◆-H■□	ARM46AC-H■	ARD-◆
AR66A◆-H■□	ARM66AC-H■	
AR98A◆-H■□	ARM98AC-H■	

● With electromagnetic brake

Model	Motor model	Driver model
AR46M◆-H■□	ARM46MC-H■	ARD-◆
AR66M◆-H■□	ARM66MC-H■	
AR98M◆-H■□	ARM98MC-H■	

2-5 Input/output power ratings

- in the model names represents **A** (single shaft), **B** (double shaft), or **M** (with electromagnetic brake).
 For the **AR911** standard type, ■ represents **A** (single shaft) or **B** (double shaft).
 For the geared type, ■ represents **A** (single shaft) or **M** (with electromagnetic brake).
- For geared type, ● in the model names represents the type of gear and number indicating the gear ratio.
- in the model names represents the cable length (-1, -2, -3) when the connection cable is supplied.

Model	Motor model	Driver model	Input			Output current per phase
			Voltage	Frequency	Current	
AR46■A●□	ARM46■C●	ARD-A	Single-phase 100-115 V	50/60 Hz	2.9 A	0.49 A
AR66■A●□	ARM66■C●				4.4 A	0.74 A
AR69■A□	ARM69■C				6.1 A	0.92 A
AR98■A●□	ARM98■C●				5.5 A	1.13 A
AR911■A□	ARM911■C				6.5 A	1.27 A
AR46■C●□	ARM46■C●	ARD-C	Single-phase 200-230 V	50/60 Hz	1.9 A	0.49 A
AR66■C●□	ARM66■C●				2.7 A	0.74 A
AR69■C□	ARM69■C				3.8 A	0.92 A
AR98■C●□	ARM98■C●				3.4 A	1.13 A
AR911■C□	ARM911■C				4.1 A	1.27 A
AR46■S●□	ARM46■C●	ARD-S	Three-phase 200-230 V	50/60 Hz	1.0 A	0.49 A
AR66■S●□	ARM66■C●				1.4 A	0.74 A
AR69■S□	ARM69■C				2.0 A	0.92 A
AR98■S●□	ARM98■C●				1.8 A	1.13 A
AR911■S□	ARM911■C				2.2 A	1.27 A

2-6 Names and functions of parts

■ Motor (Example: ARM66MC)

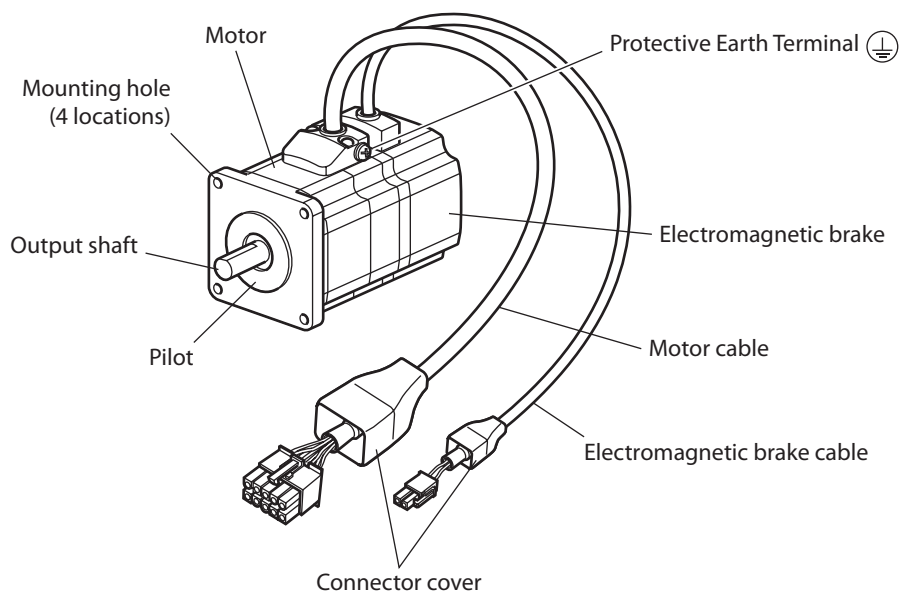

■ Driver (Example: 200-230 V input type)

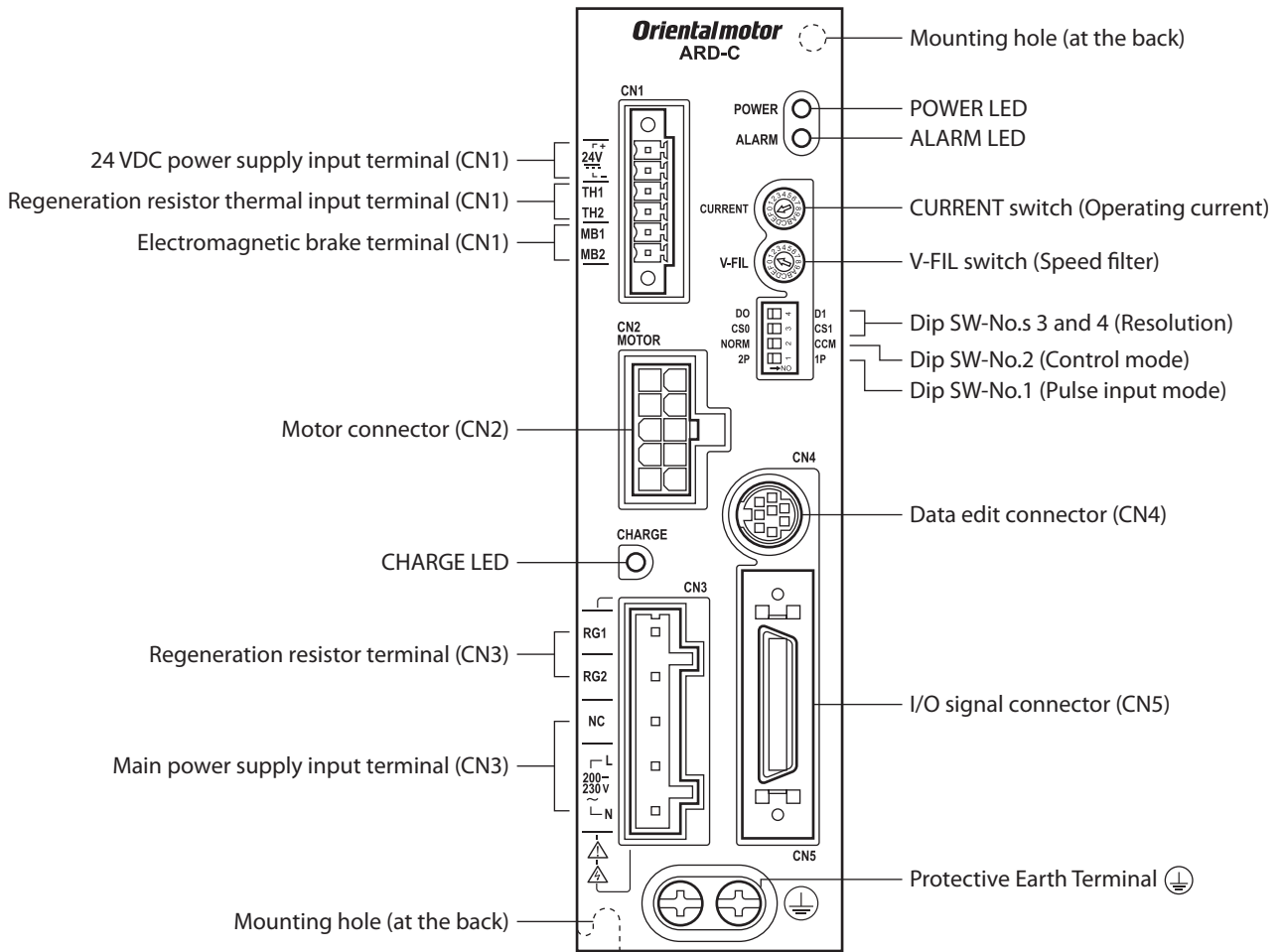

2 AC power input type

Name	Description	Page
POWER LED (Green)	This LED is lit while the main power or 24 VDC power is input.	-
ALARM LED (Red)	This LED will blink when an alarm generates. It is possible to check the generated alarm by counting the number of times the LED blinks.	p.142
CURRENT switch (Operating current)	This switch adjusts the operating current. It is used to limit the torque and temperature rise. A desired current can be set as a percentage (%) of the rated output current. Factory setting: F	p.53
V-FIL switch (Speed filter)	This switch adjusts the motor response. Use this switch if you want to suppress motor vibration or cause the motor to start/stop smoothly. "0" and "F" correspond to the minimum and maximum speed filter settings, respectively. Factory setting: 1	p.54
Dip SW-Nos.3 and 4 (Resolution)	These two switches are used to set the resolution per revolution of the motor output shaft. Factory setting: No.3 and No.4 are both left side (OFF) [1000 P/R]	p.52
Dip SW-No.2 (Control mode)	This switch toggles the driver between the normal mode and current control mode. Left side (OFF): Normal mode (Keep the switch in this position in normal conditions of use.) Right side (ON): Current control mode (Set the switch to this position if you want to suppress noise or vibration.) Factory setting: Left side (OFF) [Normal mode]	p.122

Name	Description	Page
Dip SW-No.1 (Pulse input mode)	This switch is used to toggle between the 1-pulse input mode and 2-pulse input mode according to the pulse output mode of the controller. Left side (OFF): 1-pulse input mode, active low Right side (ON): 2-pulse input mode, active low The factory setting of the pulse-input mode depends on the destination country.	p.53
Data edit connector (CN4)	Connects a PC in which the MEXE02 has been installed, or the OPX-2A .	p.46
I/O signal connector (CN5)	Connects the I/O signals of the controller.	p.35
Protective Earth Terminal	Used for grounding via a grounding cable of AWG16 to 14 (1.25 to 2.0 mm ²).	p.44
24 VDC power supply input terminal (CN1) [24V]	Connects 24 VDC. Once a 24 VDC power supply is connected, you can check the contents of alarms that have generated even when the main power is cut off. If a motor with an electromagnetic brake is used, be sure to connect a 24 VDC power supply as the electromagnetic brake power.	p.44
Regeneration resistor thermal input terminal (CN1) [TH1, TH2]	Connects the accessory regeneration resistor. If no regeneration resistor is connected, plug in the CN1 connector to short the TH1 and TH2 terminals. The driver is shipped with a jumper wire preassembled in the CN1 connector, so you can short the terminals by simply plugging the connector.	p.44
Electromagnetic brake terminal (CN1) [MB1, MB2]	Connects the lead wires from the electromagnetic brake (24 VDC). MB1: Electromagnetic brake – (black) MB2: Electromagnetic brake + (white)	p.44
Motor connector (CN2)	Connects the motor.	p.33
CHARGE LED (Red)	This LED is lit while the main power is input. After the main power was turned off, the LED will turn off once the residual voltage in the driver drops to a safe level.	–
Regeneration resistor terminal (CN3) [RG1, RG2]	Connects the accessory regeneration resistor.	p.44
Main power supply input terminal (CN3)	<ul style="list-style-type: none"> • Single-phase 100-115 V, single-phase 200-230 V L, N: Connects a single-phase 100-115 VAC or 200-230 VAC. • Three-phase 200-230 V L1, L2, L3: Connects a three-phase 200-230 VAC. • NC: Not used. 	p.43
Mounting hole (2 locations at the back)	These mounting holes are used to secure the driver with screws.	p.31

3 Installation

This chapter explains the installation location and installation methods of the motor and driver, along with regeneration resistor installation.

3-1 Location for installation

The motor and driver are designed and manufactured to be incorporated in equipment. Install them in a well-ventilated location that provides easy access for inspection.

The location must also satisfy the following conditions:

- Inside an enclosure that is installed indoors (provide vent holes)
- Operating ambient temperature
 - Motor: -10 to $+50$ °C ($+14$ to $+122$ °F) (non-freezing)
 - Harmonic geared type: 0 to $+40$ °C ($+32$ to $+104$ °F) (non-freezing)
 - Driver: 0 to $+50$ °C ($+32$ to $+122$ °F) (non-freezing)
- Operating ambient humidity 85% or less (non-condensing)
- Area that is free of explosive atmosphere or toxic gas (such as sulfuric gas) or liquid
- Area not exposed to direct sun
- Area free of excessive amount of dust, iron particles or the like
- Area not subject to splashing water (rain, water droplets), oil (oil droplets) or other liquids
- Area free of excessive salt
- Area not subject to continuous vibration or excessive shocks
- Area free of excessive electromagnetic noise (from welders, power machinery, etc.)
- Area free of radioactive materials, magnetic fields or vacuum
- 1000 m (3300 ft.) or lower above sea level

3-2 Installing the motor

The motor can be installed in any direction.

To allow for heat dissipation and prevent vibration, install the motor on a metal surface of sufficient strength.

● Installation method A

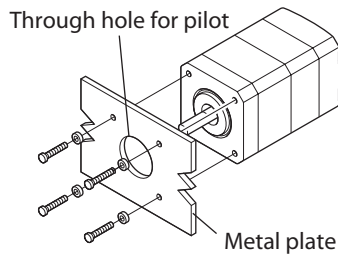

● Installation method B

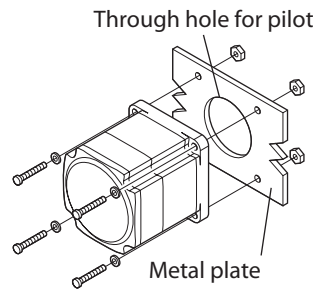

● Installation method B (FC geared type)

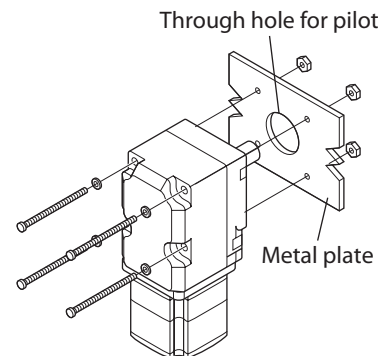

Type	Frame size [mm (in.)]	Bolt size	Tightening torque [N·m (oz-in)]	Effective depth of screw thread [mm (in.)]	Installation method
Standard	42 (1.65)	M3	1 (142)	4.5 (0.177)	A
	60 (2.36)	M4	2 (280)	–	B
	85 (3.35)	M6	3 (420)		
TH geared	42 (1.65) 60 (2.36)	M4	2 (280)	8 (0.315)	A
	90 (3.54)	M8	4 (560)	15 (0.591)	
FC geared	42 (1.65)	M4	2 (280)	–	B
	60 (2.36)	M5	2.5 (350)		
PL geared, PS geared PN geared Harmonic geared *1	42 (1.65)	M4	2 (280)	8 (0.315)	A
	60 (2.36)	M5	2.5 (350)	10 (0.394)	
	90 (3.54)	M8	4 (560)	15 (0.591)	
Harmonic geared *2	90 (3.54)	M8	4 (560)	–	B

*1 **AR46** and **AR66** type only.

*2 **AR98** type only.

3-3 Installing a load

When connecting a load to the motor, align the centers of the motor output shaft and load shaft. Flexible couplings are available as accessories.

Note

- When coupling the load to the motor, pay attention to the centering of the shafts, belt tension, parallelism of the pulleys, and so on. Securely tighten the coupling and pulley set screws.
- Be careful not to damage the output shaft or bearings when installing a coupling or pulley to the motor output shaft.
- Do not modify or machine the motor output shaft. Doing so may damage the bearings and destroy the motor.
- Do not apply strong force using hammer or other tools when removing the parallel key. Doing so may damage the motor output shaft and bearings (ball bearings).

● Using a coupling

Align the centers of the motor output shaft and load shaft in a straight line.

● Using a belt drive

Align the motor output shaft and load shaft in parallel with each other, and position both pulleys so that the line connecting their centers is at a right angle to the shafts.

● Using a gear drive

Align the motor output shaft and gear shaft in parallel with each other, and let the gears mesh at the center of the tooth widths.

• Using a coupling

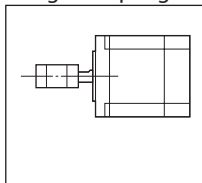

• Using a belt drive

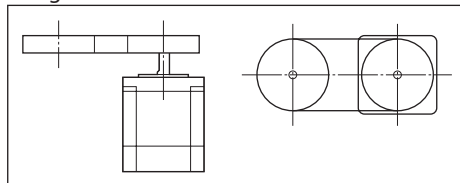

• Using a gear drive

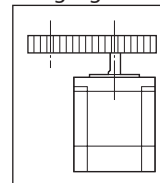

● Using a parallel key (geared motor)

When connecting the load and gear output shaft with a key slot, secure the load using the key supplied with the gear output shaft after machining the key slot on the load.

● **Harmonic geared type; Installing the load on the flange surface**

With a Harmonic geared type (excluding **AR98**), a load can be installed directly to the gear using the load mounting holes provided on the flange surface.

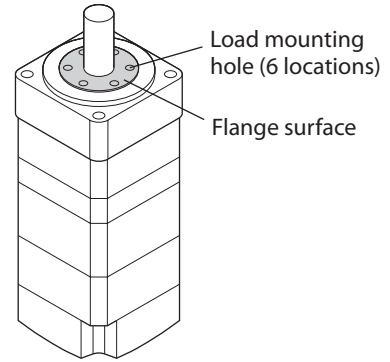

Model	Bolt size	Number of bolts	Tightening torque [N·m (oz-in)]	Effective depth of screw thread [mm (in.)]
AR46	M3	6	1.4 (198)	5 (0.197)
AR66	M4	6	2.5 (350)	6 (0.236)

- memo**
- When installing a load on the flange surface, the load cannot be mounted using the key slot in the output shaft.
 - Design an appropriate installation layout so that the load will not contact the metal plate or bolts used for installing the motor.

3-4 Permissible radial load and permissible axial load

- Note**
- If the radial load or axial load exceeds the specified allowable value, repeated load applications may cause the bearing (ball bearings) or output shaft of the motor to undergo a fatigue failure.
 - With a double shaft type, do not apply load torque, radial load or axial load to the output shaft on the opposite side of the motor output shaft.

- memo**
- The permissible radial load and permissible axial load of the **PS** geared type and **PN** geared type represent the value that the service life of the gear part satisfies 20,000 hours when either of the radial load or axial load is applied to the gear output shaft.

Type	Model	Gear ratio	Permissible radial load [N (lb.)]					Permissible axial load [N (lb.)]
			Distance from the tip of motor output shaft [mm (in.)]					
			0 (0)	5 (0.2)	10 (0.39)	15 (0.59)	20 (0.79)	
Standard	AR46	-	35 (7.8)	44 (9.9)	58 (13)	85 (19.1)	-	15 (3.3)
	AR66 AR69		90 (20)	100 (22)	130 (29)	180 (40)	270 (60)	30 (6.7)
	AR98 AR911		260 (58)	290 (65)	340 (76)	390 (87)	480 (108)	60 (13.5)
TH geared	AR46	All gear ratio	10 (2.2)	14 (3.1)	20 (4.5)	30 (6.7)	-	15 (3.3)
	AR66		70 (15.7)	80 (18)	100 (22)	120 (27)	150 (33)	40 (9)
	AR98		220 (49)	250 (56)	300 (67)	350 (78)	400 (90)	100 (22)
FC geared	AR46	All gear ratio	180 (40)	200 (45)	220 (49)	250 (56)	-	100 (22)
	AR66		270 (60)	290 (65)	310 (69)	330 (74)	350 (78)	200 (45)
PL geared	AR46	5, 7.2, 10	73 (16.4)	84 (18.9)	100 (22)	123 (27)	-	50 (11.2)
		25, 36, 50	109 (24)	127 (28)	150 (33)	184 (41)	-	
	AR66	5	200 (54)	220 (49)	250 (56)	280 (63)	320 (72)	100 (22)
		7.2, 10	250 (56)	270 (60)	300 (67)	340 (76)	390 (87)	
		25, 36, 50	330 (74)	360 (81)	400 (90)	450 (101)	520 (117)	
	AR98	5, 7.2, 10	480 (108)	540 (121)	600 (135)	680 (153)	790 (177)	300 (67)
		25	850 (191)	940 (210)	1050 (230)	1190 (260)	1380 (310)	
		36	930 (200)	1030 (230)	1150 (250)	1310 (290)	1520 (340)	
50		1050 (230)	1160 (260)	1300 (290)	1480 (330)	1710 (380)		

Type	Model	Gear ratio	Permissible radial load [N (lb.)]					Permissible axial load [N (lb.)]	
			Distance from the tip of motor output shaft [mm (in.)]						
			0 (0)	5 (0.2)	10 (0.39)	15 (0.59)	20 (0.79)		
PS geared	AR46	5	70 (15.7)	80 (18)	95 (21)	120 (27)	–	100 (22)	
		7.2	80 (18)	90 (20)	110 (24)	140 (31)	–		
		10	85 (19.1)	100 (22)	120 (27)	150 (33)	–		
		25	120 (27)	140 (31)	170 (38)	210 (47)	–		
		36	130 (29)	160 (36)	190 (42)	240 (54)	–		
		50	150 (33)	170 (38)	210 (47)	260 (58)	–		
	AR66	5	170 (38)	200 (45)	230 (51)	270 (60)	320 (72)	200 (45)	
		7.2	200 (45)	220 (49)	260 (58)	310 (69)	370 (83)		
		10	220 (49)	250 (56)	290 (65)	350 (78)	410 (92)		
		25	300 (67)	340 (76)	400 (90)	470 (105)	560 (126)		
		36	340 (76)	380 (85)	450 (101)	530 (119)	630 (141)		
		50	380 (85)	430 (96)	500 (112)	600 (135)	700 (157)		
	AR98	5	380 (85)	420 (94)	470 (105)	540 (121)	630 (141)	600 (135)	
		7.2	430 (96)	470 (105)	530 (119)	610 (137)	710 (159)		
		10	480 (108)	530 (119)	590 (132)	680 (153)	790 (177)		
		25	650 (146)	720 (162)	810 (182)	920 (200)	1070 (240)		
		36	730 (164)	810 (182)	910 (200)	1040 (230)	1210 (270)		
		50	820 (184)	910 (200)	1020 (220)	1160 (260)	1350 (300)		
PN geared	AR46	5	80 (18)	95 (21)	120 (27)	160 (36)	–	100 (22)	
		7.2	90 (20)	110 (24)	130 (29)	180 (40)	–		
		10	100 (22)	120 (27)	150 (33)	200 (45)	–		
	AR66	5	240 (54)	260 (58)	280 (63)	300 (67)	330 (74)	200 (45)	
		7.2	270 (60)	290 (65)	310 (69)	340 (76)	370 (83)		
		10	300 (67)	320 (72)	350 (78)	380 (85)	410 (92)		
		25	410 (92)	440 (99)	470 (105)	520 (117)	560 (126)		
		36	360 (81)	410 (92)	480 (108)	570 (128)	640 (144)		
		50	360 (81)	410 (92)	480 (108)	570 (128)	700 (157)		
	AR98	5	370 (83)	390 (87)	410 (92)	430 (96)	460 (103)	600 (135)	
		7.2	410 (92)	440 (99)	460 (103)	490 (110)	520 (117)		
		10	460 (103)	490 (110)	520 (117)	550 (123)	580 (130)		
		25	630 (141)	660 (148)	700 (157)	740 (166)	790 (177)		
		36	710 (159)	750 (168)	790 (177)	840 (189)	900 (200)		
		50	790 (177)	840 (189)	890 (200)	940 (210)	1000 (220)		
	Harmonic geared	AR46	All gear ratio	180 (40)	220 (49)	270 (60)	360 (81)	510 (114)	220 (49)
		AR66		320 (72)	370 (83)	440 (99)	550 (123)	720 (162)	450 (101)
		AR98		1090 (240)	1150 (250)	1230 (270)	1310 (290)	1410 (310)	1300 (290)

■ **Permissible moment load of the Harmonic geared type**

If an eccentric load is applied on the flange surface when installing an arm or a table, do not exceed the permissible value shown in the table.

Model	Permissible moment load [N·m (oz-in)]
AR46	5.6 (790)
AR66	11.6 (1640)

Use the calculating formula below for the moment load.

- **Example 1; When an external force F is applied on the position of distance L from the center of the output flange**

L: Distance from the center of the output flange [m (in.)]

F: External force [N (oz)]

Moment load: $M [N·m (oz-in)] = F \times L$

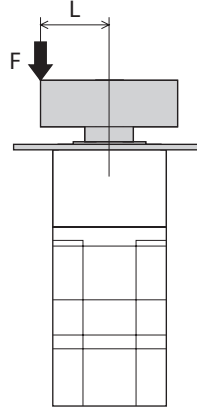

- **Example 2; When external force F is applied on the position of distance L from the mounting face of the output flange**

L: Distance from the mounting face of the output flange [m (in.)]

F: External force [N (oz)]

Moment load: $M [N·m (oz-in)] = F \times (L + \text{coefficient "a"})$

Model	coefficient "a"
AR46	0.009
AR66	0.0114

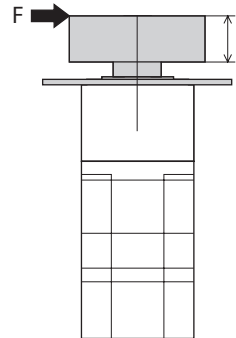

3-5 Installing the driver

The driver is designed so that heat is dissipated via air convection and conduction through the enclosure. Install the driver on a flat metal plate [material: aluminium, 200×200×2 mm (7.87×7.87×0.08 in.) equivalent] having excellent heat conductivity. When two or more drivers are to be installed side by side, provide 20 mm (0.79 in.) and 25 mm (0.98 in.) clearances in the horizontal and vertical directions, respectively. When installing the driver in an enclosure, use two screws (M4, not supplied) to secure the driver through the mounting holes.

- memo**
- Install the driver in an enclosure whose pollution degree is 2 or better environment, or whose degree of protection is IP54 minimum.
 - Do not install any equipment that generates a large amount of heat or noise near the driver.
 - Do not install the driver underneath the controller or other equipment vulnerable to heat.
 - Check ventilation if the ambient temperature of the driver exceeds 50 °C (122 °F).
 - Be sure to install the driver vertically (vertical position).

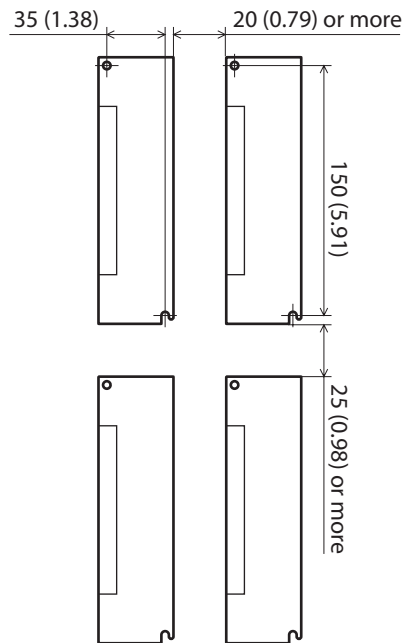

Unit: mm (in.)

Dimension [unit: mm (in.)]

Mass: 0.75 kg (1.65 lb.)

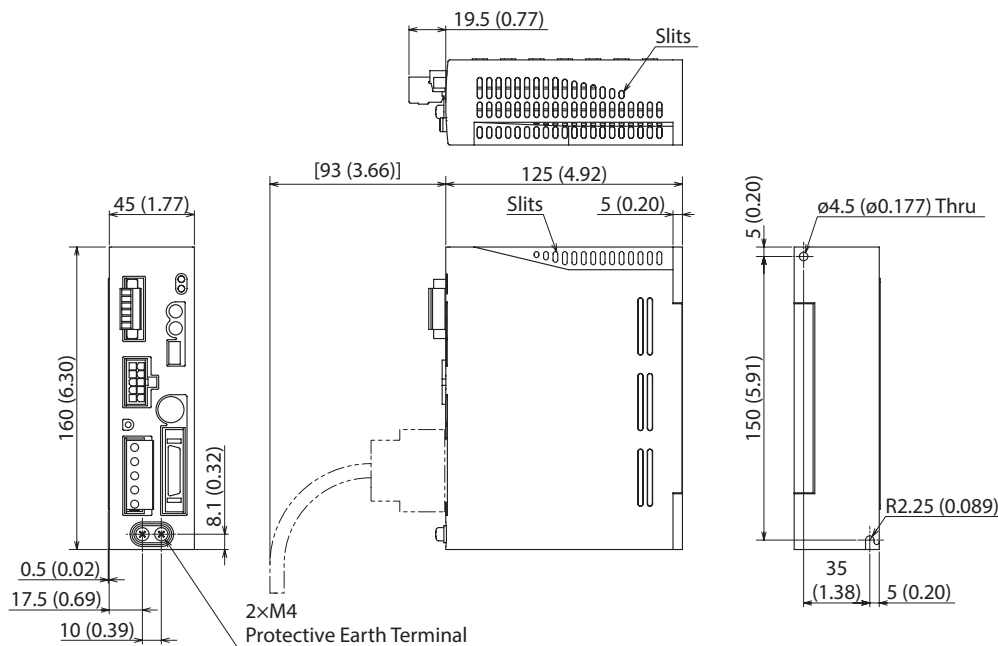

2 AC power input type

3-6 Installing the regeneration resistor

Install the accessory regeneration resistor in a location where heat dissipation capacity equivalent to a level achieved with a heat sink [made of aluminum, 350×350×3 mm (13.78×13.78×0.12 in.)] is ensured.
 Affix the regeneration resistor on a smooth metal plate offering high heat conductivity, using two screws (M4, not supplied).

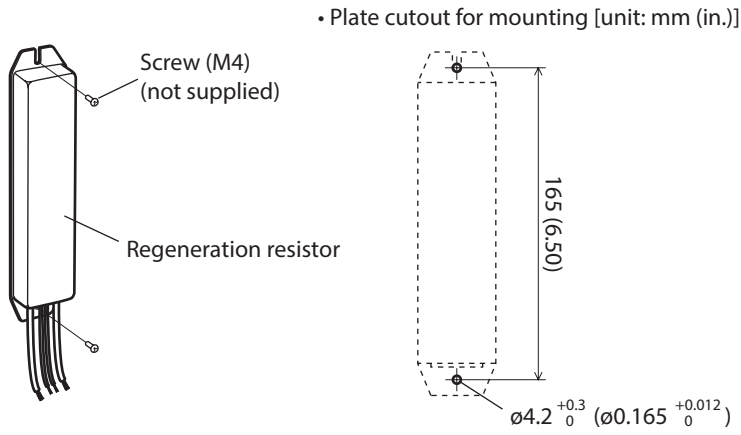

4 Connection

This chapter explains how to connect the motor, I/O signals and power supply to the driver, as well as grounding method. The installation and wiring methods in compliance with the EMC Directive as well as protection against noise are also explained.

⚠ WARNING

- For protection against electric shock, do not turn on the power supply until the wiring is completed.
- A high voltage is applied to the motor connector (CN2) and the main power supply input terminal (CN3). Do not touch these terminals while the power is on. Doing so may result in fire or electric shock.

4-1 Connection example

The following figure shows models for the electromagnetic brake type and single-phase 200 to 230 VAC input.

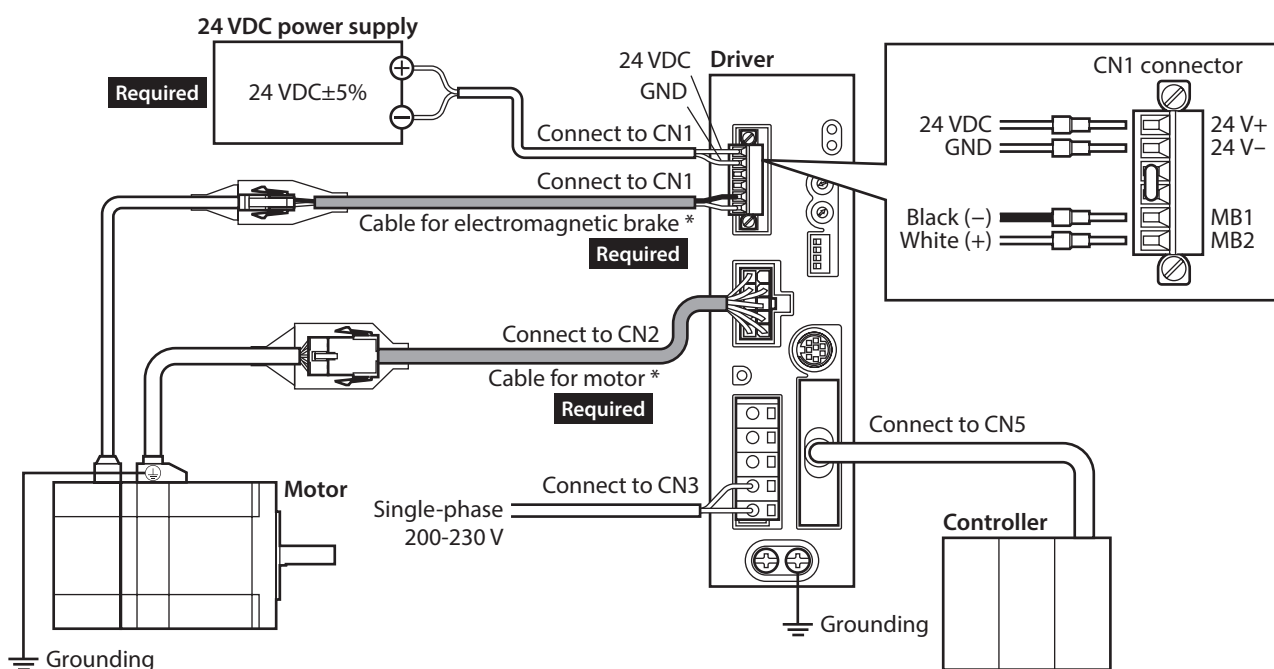

2 AC power input type

* Cables represented in gray color are supplied with the product or sold separately. Keep 30 m (98.4 ft.) or less for the wiring distance between the motor and driver.

Note

- Have the connector plugged in securely. Insecure connector connection may cause malfunction or damage to the motor or driver.
- When plugging/unplugging the connector, turn off the power and wait for the CHARGE LED to turn off before doing so. The residual voltage may cause electric shock.
- The lead wires of the "cable for electromagnetic brake" have polarities, so connect them in the correct polarities. If the lead wires are connected with their polarities reversed, the electromagnetic brake will not operate properly.

memo

- If the distance between the motor and driver is extended to 20 m (65.6 ft.) or longer, use a power supply of 24 VDC±4%.
- When unplugging the connector, do so while pressing the latches on the connector.
- When installing the motor to a moving part, use an accessory flexible cable offering excellent flexibility. Refer to p.55 for details.

● Cable size and tightening torque

Connector	Terminal symbol	Recommended cable size	Screw size	Tightening torque [N·m (oz-in)]
CN1	24V+, 24V-	Stranded wire AWG28 to 16 (0.08 to 1.25 mm ²)	M2	0.22 to 0.25 (31 to 35)
	TH1, TH2	Stranded wire AWG22 (0.3 mm ²)		
	MB1, MB2	Stranded wire AWG20 (0.5 mm ²)		
CN3	RG1, RG2	Stranded wire AWG18 (0.75 mm ²)	-	-
	L, N L1, L2, L3	Stranded wire AWG16 to 14 (1.25 to 2.0 mm ²)		
CN5	-	Stranded wire AWG28 to 24 (0.08 to 0.2 mm ²)	-	-

● Current capacity of the 24 VDC power supply

Model	Current capacity
AR46	0.58 A or more
AR66 AR69 AR98 AR911	0.75 A or more

4-2 Connecting the I/O signals

Solder the I/O signal cable (AWG28 to 24: 0.08 to 0.2 mm²) to the CN5 connector (36 pins) while checking the pin numbers in the "Connector function table" provided below. Use a shielded cable for I/O signals. We provide an accessory driver cable allowing simple and easy connection with a driver, as well as connector-terminal block conversion unit. Refer to p.58 for details.

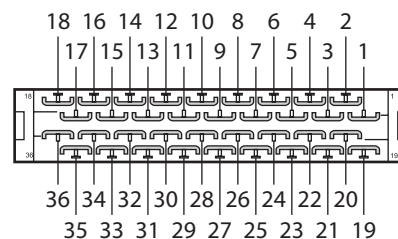

■ Connector function table

Pin No.	Operating mode		Signal name	
	Positioning operation	Push-motion operation *	Positioning operation	Push-motion operation *
1	-		-	
2	GND		Ground connection	
3	ASG+		A-phase differential output (Line driver)	
4	ASG-			
5	BSG+		B-phase differential output (Line driver)	
6	BSG-			
7	TIM1+		Timing differential output (Line driver)	
8	TIM1-			
9	ALM+		Alarm output	
10	ALM-			
11	WNG+		Warning output	
12	WNG-			
13	END+		Positioning complete output	
14	END-			
15	READY+/AL0+ *		Operation ready complete output/Alarm code output 0 *	
16	READY-/AL0- *			
17	TLC+/AL1+ *		Torque limit output/Alarm code output 1 *	
18	TLC-/AL1- *			
19	TIM2+/AL2+ *		Timing output (open collector)/Alarm code output 2 *	
20	TIM2-/AL2- *			
21	GND		Ground connection	
22	IN-COM		Input common	
23	C-ON		Current on input	
24	CLR/ALM-RST		Deviation clear input/Alarm reset input	
25	CCM		Current control mode ON input	
26	CS	T-MODE *	Resolution selection input	Push-motion operation ON *
27	-	M0 *	-	Push-current setting selection input *
28	RETURN	M1 *	Return to electrical home operation	
29	P-RESET	M2 *	Position reset input	
30	FREE		Excitation OFF, release the electromagnetic brake input	
31	CW+/PLS+		CW pulse input/Pulse input (+5 V or line driver)	
32	CW-/PLS-			
33	CW+24 V/PLS+24 V		CW pulse input/Pulse input (+24 V)	
34	CCW+24 V/DIR+24 V		CCW pulse input/Direction input (+24 V)	
35	CCW+/DIR+		CCW pulse input/Direction input (+5 V or line driver)	
36	CCW-/DIR-			

* The signal will be enabled if the applicable setting was changed using the **MEXE02** or **OPX-2A**.

Note The factory setting of the C-ON input is normally open. Be sure to turn the C-ON input ON when operating the motor. Set the C-ON input to normally closed when the C-ON input is not used. Refer to p.96 for details.

■ **Assembling the connector**

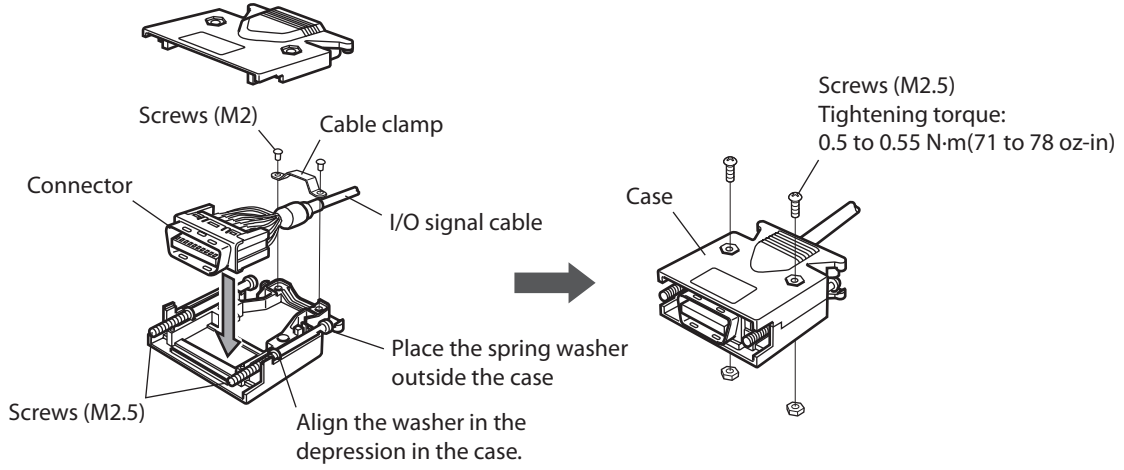

■ **Connecting the connector**

Insert the CN5 connector into the I/O signal connector (CN5) on the driver, and tighten the screw.
Tightening torque: 0.3 to 0.35 N·m (42 to 49 oz-in)

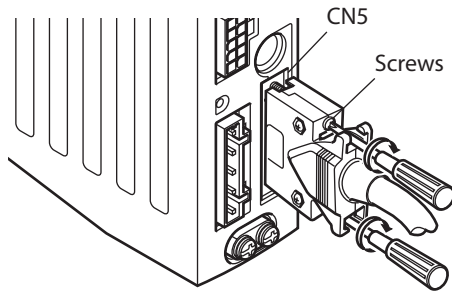

Note Be certain the I/O signal cable is as short as possible. The maximum input frequency will decrease as the cable length increases.

■ Connecting to a current sink output circuit

- When pulse input is of line driver type

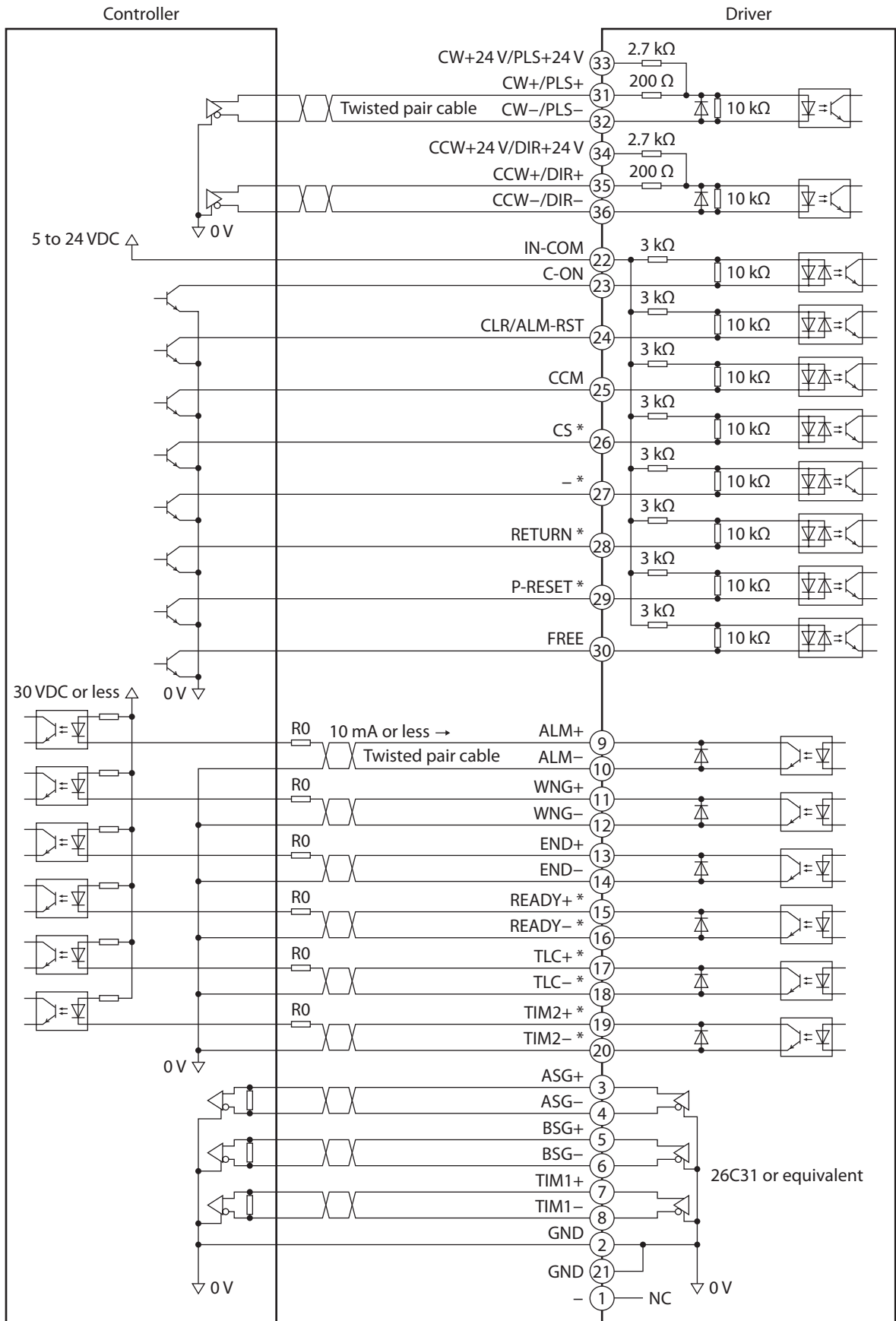

2 AC power input type

* Initial value

- memo
 Use output signals at 30 VDC or less. If the current exceeds 10 mA, connect an external resistor R0.
- The ASG output, BSG output and TIM1 output are line driver outputs. When connecting a line driver output, receive the output signal using a line receiver. Also, be sure to connect pins 2 or 21 of the driver to the GND on the line receiver, and connect a termination resistor of 100 Ω or more between the driver and the input of the line receiver.

● When pulse input is of open collector type (input voltage 5 VDC)

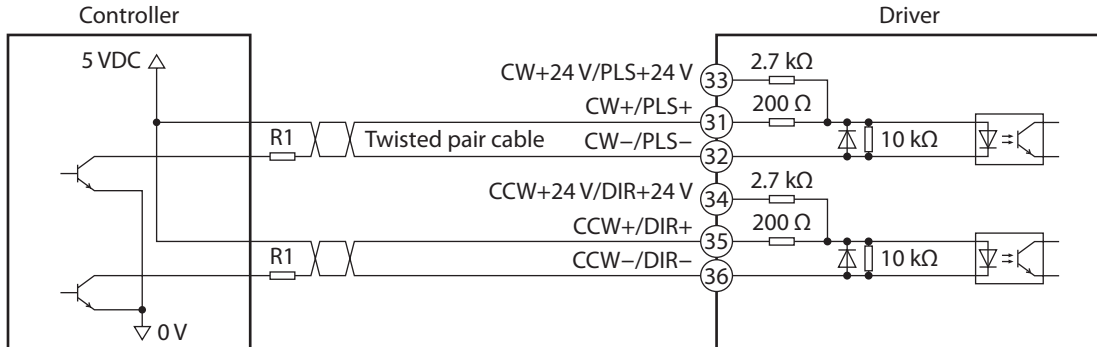

- memo
 When the 12 VDC is used, be sure to connect an external resistor R1 (1 kΩ, 0.25 W or more) so that the current exceeding 20 mA does not flow.

● When pulse input is of open collector type (input voltage 24 VDC)

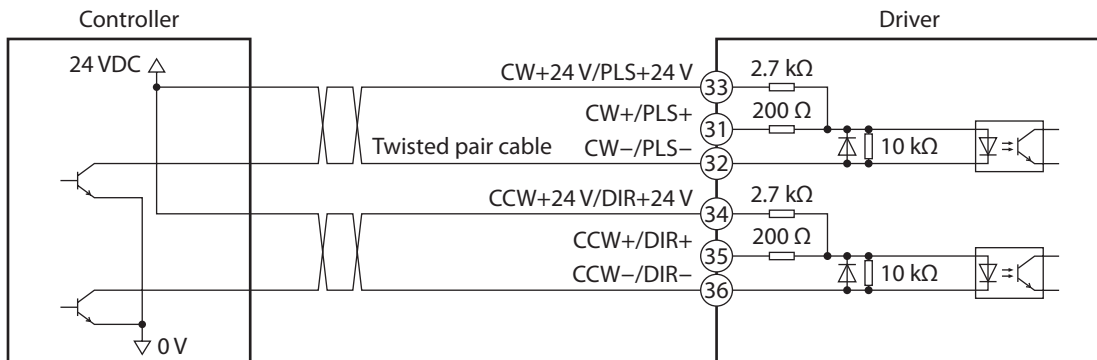

■ Connecting to a current source output circuit

- When pulse input is of line driver type

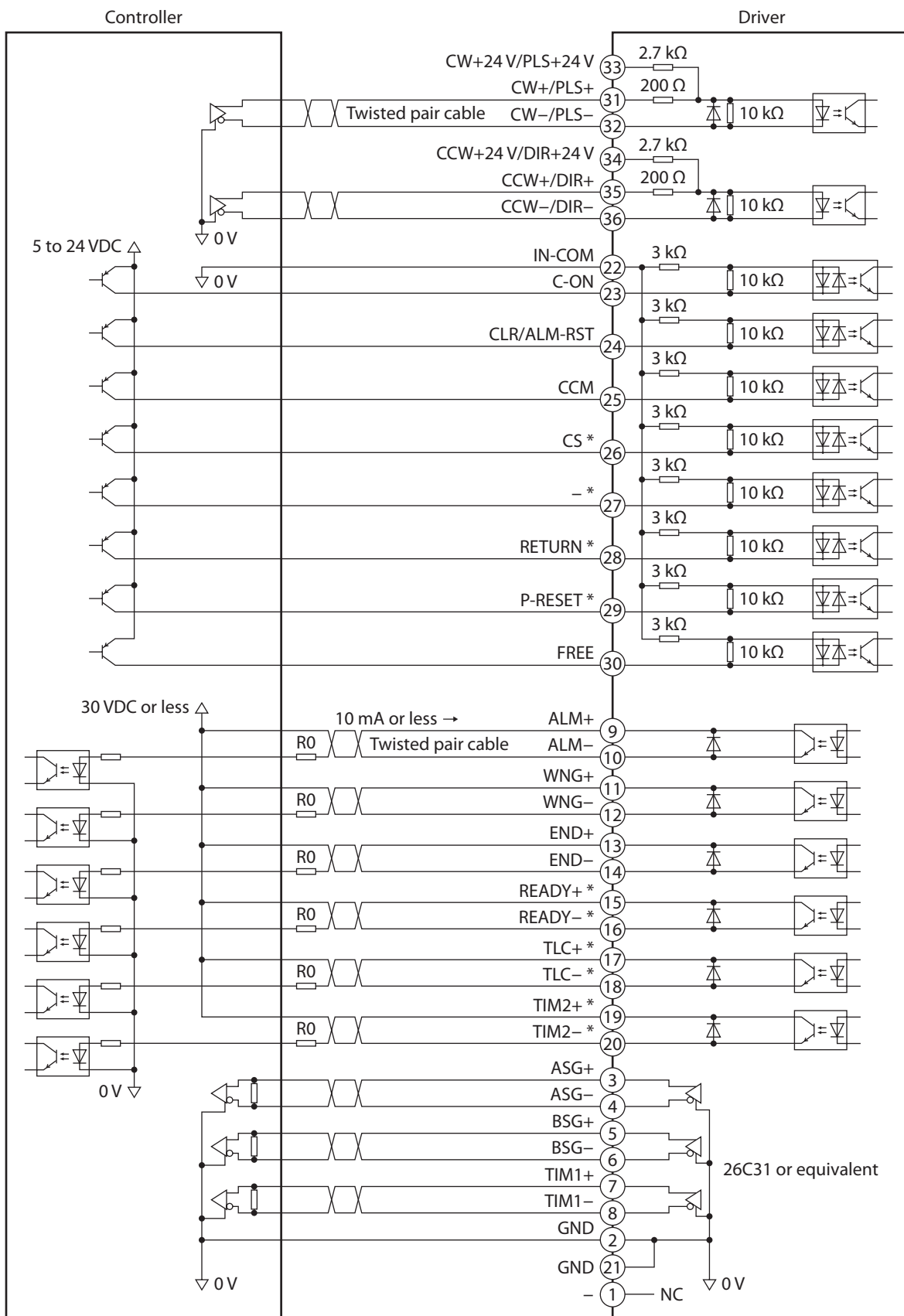

* Initial value

2 AC power input type

- memo
 Use output signals at 30 VDC or less. If the current exceeds 10 mA, connect an external resistor R0.
- The ASG output, BSG output and TIM1 output are line driver outputs. When connecting a line driver output, receive the output signal using a line receiver. Also, be sure to connect pins 2 or 21 of the driver to the GND on the line receiver, and connect a termination resistor of 100 Ω or more between the driver and the input of the line receiver.

● When pulse input is of open collector type (input voltage 5 VDC)

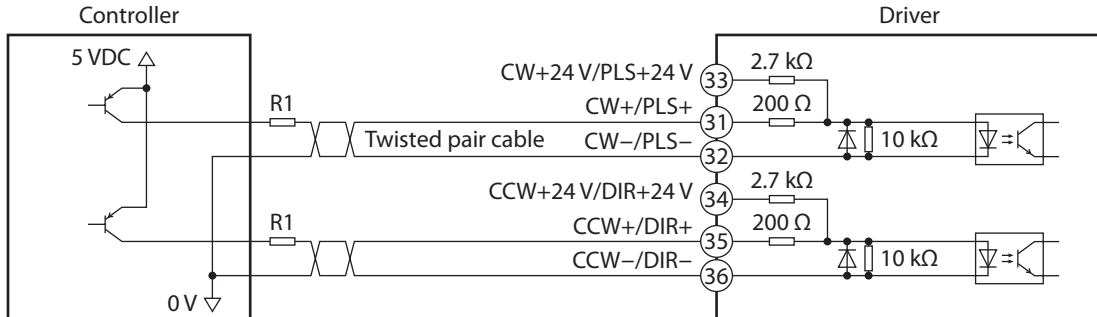

- memo
 When the 12 VDC is used, be sure to connect an external resistor R1 (1 kΩ, 0.25 W or more) so that the current exceeding 20 mA does not flow.

● When pulse input is of open collector type (input voltage 24 VDC)

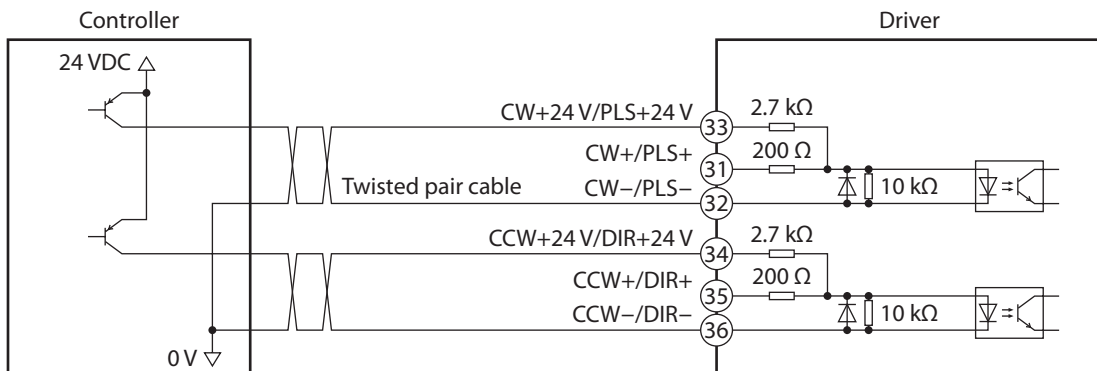

■ Timing charts

● When no 24 VDC power supply is connected to CN1

When turning the main power supply on and turning the C-ON input ON, the motor will be excited. The READY output will turn ON and pulse input will be enabled.

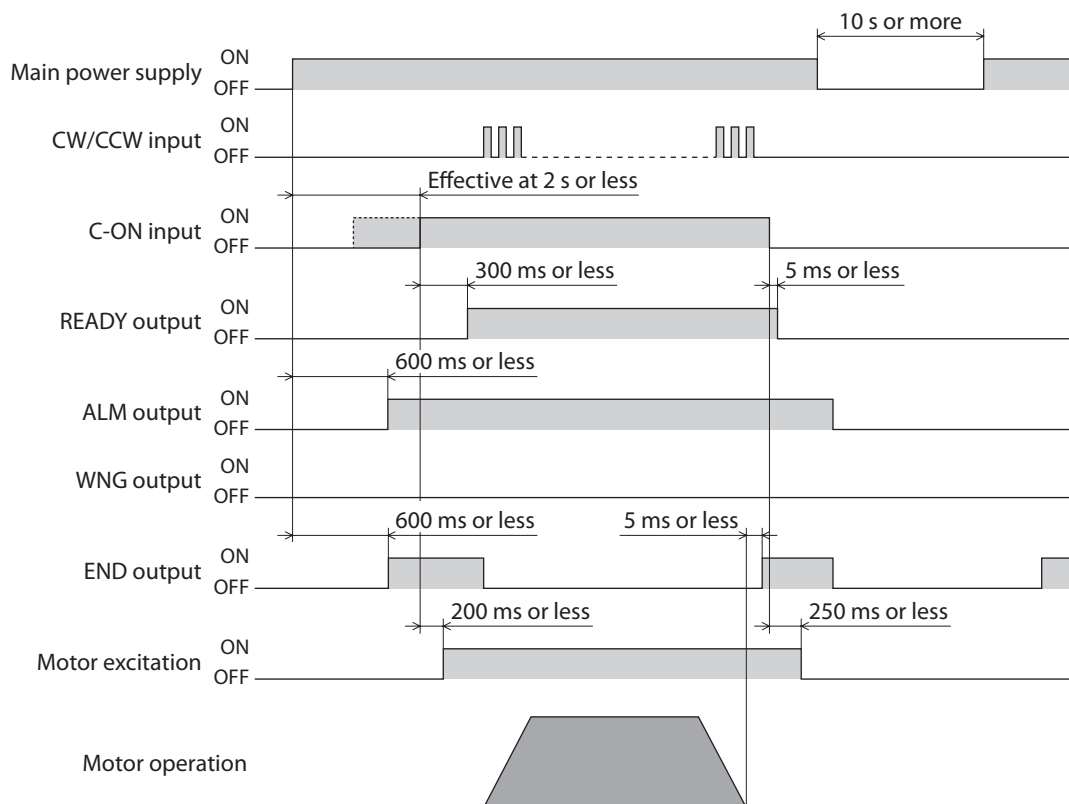

● When a 24 VDC power supply is connected to CN1

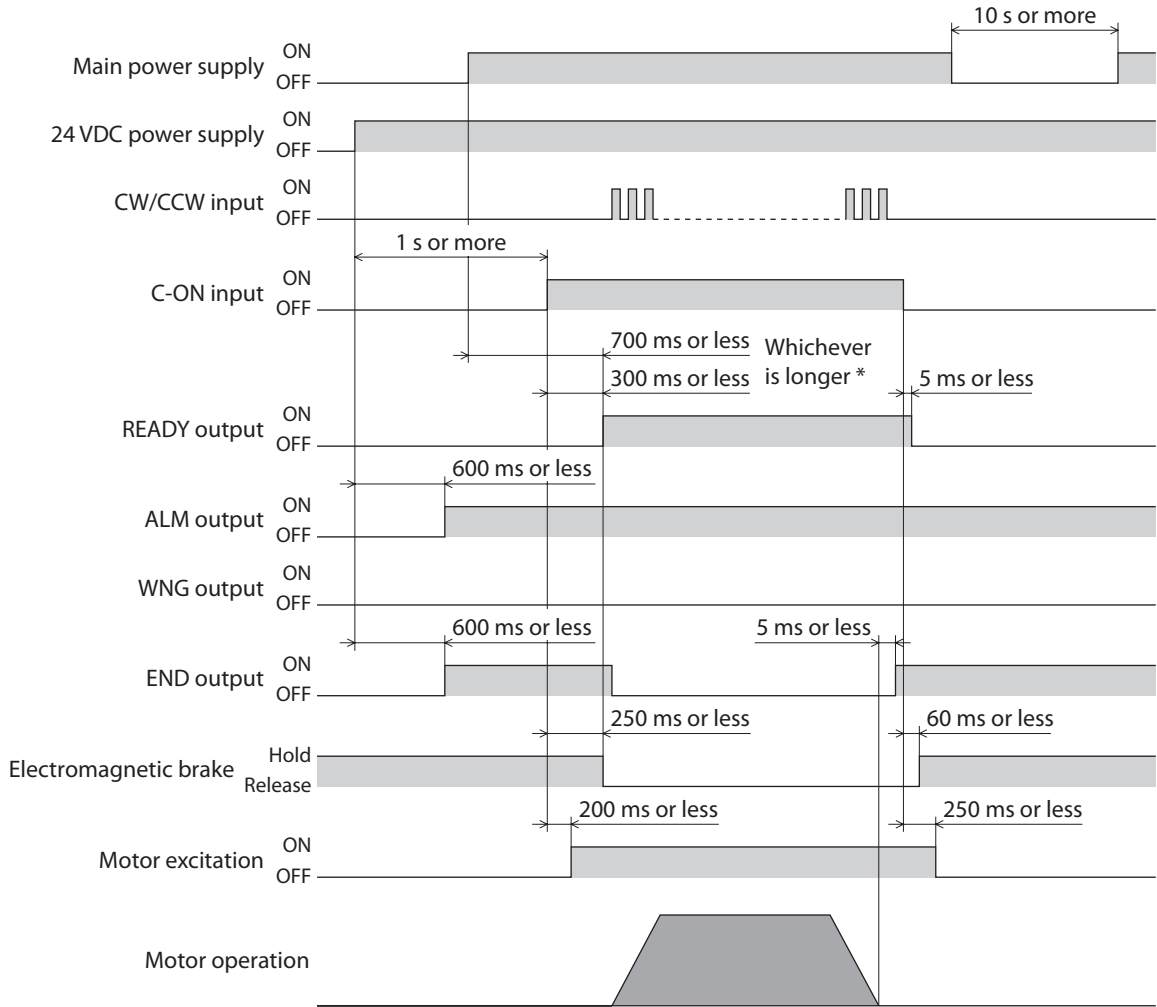

* The specific time varies depending on the timing at which the C-ON input is turned ON.

4-3 Connecting the power supply

Use the CN3 connector (5 pins) to connect the power supply cable (AWG16 to 14: 1.25 to 2.0 mm²) to the main power supply connector (CN3) on the driver.

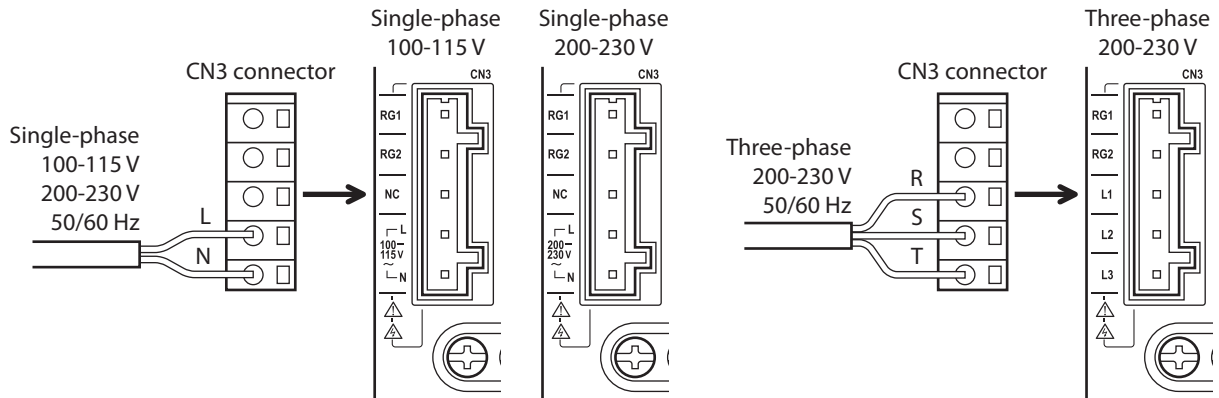

Note

- Do not wire the power supply cable of the driver in the same cable duct with other power lines or motor cables. Doing so may cause malfunction due to noise.
- When cycling the power or plugging/unplugging the connector, turn off the power and wait for the CHARGE LED to turn off. The residual voltage may cause electric shock.

■ Connecting method of the power supply cable

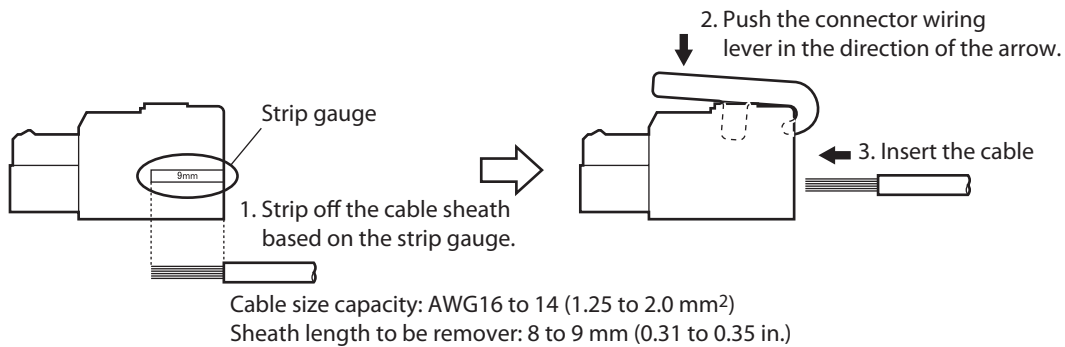

You can also connect the power supply cable using a flat-tip screwdriver.

Insert a flat-tip screwdriver with a tip of 3.0 to 3.5 mm (0.12 to 0.14 in.) in width into the insertion port and push. In this condition, insert the cable.

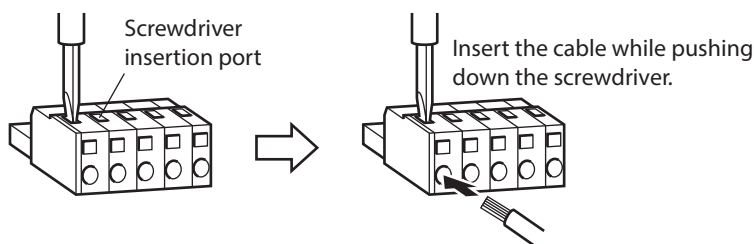

■ Power supply current capacity

Model	Single-phase 100-115 V -15 to +10% 50/60 Hz	Single-phase 200-230 V -15 to +10% 50/60 Hz	Three-phase 200-230 V -15 to +10% 50/60 Hz
AR46	2.9 A or more	1.9 A or more	1.0 A or more
AR66	4.4 A or more	2.7 A or more	1.4 A or more
AR69	6.1 A or more	3.8 A or more	2.0 A or more
AR98	5.5 A or more	3.4 A or more	1.8 A or more
AR911	6.5 A or more	4.1 A or more	2.2 A or more

4-4 Grounding the motor and driver

■ Grounding the motor

Be sure to ground the Protective Earth Terminal of the motor.

- Screw size: M4
- Tightening torque: 1.2 N·m (170 oz-in)

Use a grounding wire of AWG18 (0.75 mm²) or more.

Use a round, terminal in combination with an inner-clip washer and bolt it in place to secure the grounding connection. Ground wires and crimp terminals are not supplied.

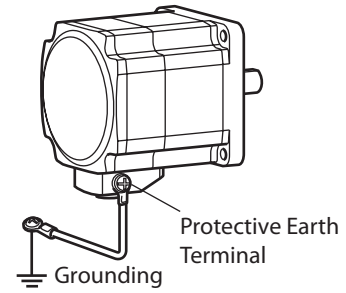

■ Grounding the driver

Be sure to ground the protective earth terminal of the driver.

- Screw size: M4
- Tightening torque: 1.2 N·m (170 oz-in)

You can ground either of the two protective earth terminals. The terminal not grounded should be connected to the protective earth lead of the motor cable.

Use a grounding wire (AWG16 to 14: 1.25 to 2.0 mm²), and do not share the protective earth terminal with a welder or any other power equipment.

When grounding the protective earth terminal, use a round terminal and secure the grounding point near the driver.

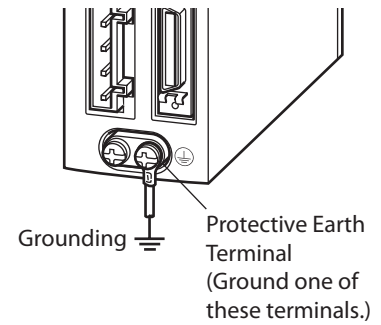

4-5 Connecting the 24 VDC power supply, regeneration resistor and electromagnetic brake

Use the CN1 connector (6 pins) to connect the 24 VDC power supply, regeneration resistor and electromagnetic brake. Connect the lead wire (AWG28 to 16: 0.08 to 1.25 mm²) to the connector while checking the pin numbers in below.

Display	Description
24V+	24 VDC power supply input (Be sure to connect these pins when an electromagnetic brake is used.)
24V-	
TH1	Regeneration resistor thermal input (If these pins are not used, short it using a jumper wire.)
TH2	
MB1	Electromagnetic brake – (Connect the black lead wire of the electromagnetic brake.)
MB2	Electromagnetic brake + (Connect the white lead wire of the electromagnetic brake.)

■ Connecting method

1. Strip the insulation cover of the lead wire by 7 mm (0.28 in.)
2. Insert each lead wire into the CN1 connector and tighten the screw with a screwdriver.
Connector screw size: M2
Tightening torque: 0.22 to 0.25 N·m (31 to 35 oz-in)
3. Insert the CN1 connector into the CN1, and tighten the screw.
Connector screw size: M2.5
Tightening torque: 0.4 N·m (56 oz-in)

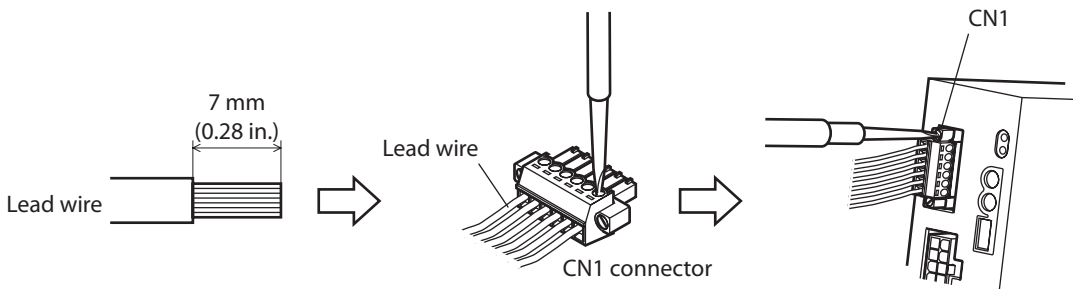

■ Connecting the 24 VDC power supply

Use the 24 VDC±5% power supply of the following capacity.

Model	Without electromagnetic brake	With electromagnetic brake
AR46	0.5 A or more	0.58 A or more
AR66, AR69, AR98, AR911		0.75 A or more

Once a 24 VDC power supply is connected, you can check the contents of alarms that have generated even when the main power is cut off.

If a motor with electromagnetic brake is used, be sure to connect a 24 VDC power supply as the electromagnetic brake power.

Since the 24 VDC power supply is not used for operating the motor, connect it as necessary.

- memo**
- If the distance between the motor and driver is extended to 20 m (65.6 ft.) or longer, use a power supply of 24±4% VDC.
 - When cycling the 24 VDC power supply, turn off the power and wait for at least 1 second before turning on.

■ Connecting the regeneration resistor

Connect an accessory regeneration resistor if vertical drive (gravitational operation) such as elevator applications is performed or if sudden start-stop operation of a large inertial load is repeated frequently.

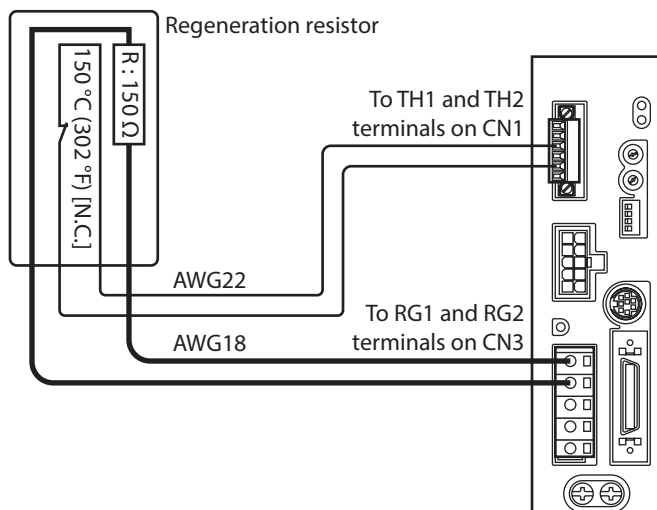

- The two thin lead wires (AWG22: 0.3 mm²) of the regeneration resistor are the thermostat outputs. Connect them to the TH1 and TH2 terminals using the CN1 connector.
- Regenerative current flows through the two thick lead wires (AWG18: 0.75 mm²) of the regeneration resistor. Connect them to the RG1 and RG2 terminals using the CN3 connector.



- Before connecting the regeneration resistor, be sure to remove the jumper wire from the CN1 connector.
- If the current consumption of the regeneration resistor exceeds the allowable level, the thermostat will be triggered and a regeneration resistor overheat alarm will generate. If a regeneration resistor overheat alarm generates, turn off the power and check the content of the error.

Regeneration resistor specifications

Model	RGB100
Allowable current consumption	Continuous regenerative power: 50 W * Instantaneous regenerative power: 600 W
Resistance	150 Ω
Operating temperature of thermostat	Operation:Opens at 150±7 °C (302±12.6 °F) Reset:Closes at 145±12 °C (293±21.6 °F) (normally closed)
Electrical rating of thermostat	120 VAC 4 A, 30 VDC 4 A (minimum current: 5 mA)

* Install the regeneration resistor in a location where heat dissipation capacity equivalent to a level achieved with a heat sink [made of aluminum, 350×350×3 mm (13.78×13.78×0.12 in.)] is ensured.

■ **Connecting the electromagnetic brake**

When the electromagnetic brake is connected, it can automatically be controlled by interlocking with the C-ON input or the FREE input. Refer to p.33 for connection method.

4-6 Connecting the data setter

Connect the communication cable for the support software or **OPX-2A** cable to the data edit connector (CN4) on the driver.

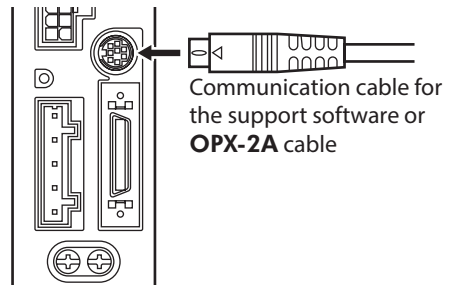

⚠ CAUTION

The data edit connector (CN4) and I/O signal connector (CN5) of the driver are not electrically insulated. When grounding the positive terminal of the power supply, do not connect any equipment (PC, etc.) whose negative terminal is grounded. Doing so may cause the driver and these equipment to short, damaging both.

4-7 Noise measures

The electrical noise is of two types: One is a noise to invade into the driver from the outside and cause the driver malfunction, and the other is a noise to emit from the driver and cause peripheral equipments malfunction. For the noise that is invaded from the outside, take measures to prevent the driver malfunction. It is needed to take adequate measures because signal lines are very likely to be affected by the noise. For the noise that is emitted from the driver, take measures to suppress it.

■ Measures against electrical noise

There are the following three methods mainly to take measures against the electrical noise.

● Noise suppression

- When relays or electromagnetic switches are used together with the system, use noise filters and CR circuits to suppress surges generated by them.
- Use an accessory cable when extending a wiring distance between the motor and driver.
- Cover the driver by a metal plate such as aluminum. This is effective in shielding the electrical noise emitted from the driver.

● Prevention of noise propagation

- Connect a noise filter in the power supply cable of driver.
- Place the power lines, such as the motor and power supply cables, keeping a distance of 200 mm (7.87 in.) or more from the signal lines, and also do not bundle them or wire them in parallel. If the power cables and signal cables have to cross, cross them at a right angle.
- Use shielded twisted pair cables for power lines and signal lines.
- Keep cables as short as possible without coiling and bundling extra lengths.
- When grounding PE terminals of multiple drivers to a grounding point, it becomes more effective to block the electrical noise since impedance on the grounding point is decreased. However, ground them so that a potential difference does not occur among the grounding points. An accessory driver cable including with a ground wire is available. Refer to p.57 for details.
- To ground a shielded cable, use a metal cable clamp that will maintain contact with the entire circumference of the cable. Ground the cable clamp near the product.

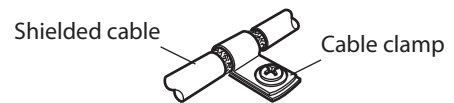

● Suppression of effect by noise propagation

- Loop the noise propagated cable around a ferrite core. Doing so will prevent the propagated noise invades into the driver or emits from the driver. The frequency band in which an effect by the ferrite core can be seen is generally 1 MHz or more. Check the frequency characteristics of the ferrite core used. To increase the effect of noise attenuation by the ferrite core, loop the cable a lot.
- Change the transmission method of the pulse signal to the line driver type in order to prevent noise effects. When the pulse signal of the controller is the open collector type, use an accessory pulse signal converter for noise immunity. Refer to p.58 for details.

■ Noise suppression parts

● Noise filter

- Connect the following noise filter (or equivalent) to the power line. Doing so will prevent the propagated noise through the power line. Install the noise filter as close to the driver as possible.

Manufacture	Single-phase 100-115 V Single-phase 200-230 V	Three-phase 200-230 V
SOSHIN ELECTRIC CO.,LTD	HF2010A-UPF	HF3010C-SZA
Schaffner EMC	FN2070-10-06	FN3025HP-10-71

- Use the AWG18 (0.75 mm²) or thicker wire for the input and output cables of the noise filter, and secure firmly using a cable clamp etc. so that the cable does not come off the enclosure.
- Place the input cable as far apart as possible from the output cable, and do not wire the cables in parallel. If the input and output cable are placed at a close distance or if they are wired in parallel, the noise in the enclosure affects the power cable through stray capacitance, and the noise suppressing effect will reduce.
- Connect the ground terminal of the noise filter to the grounding point, using as thick and short a wire as possible.
- When connecting a noise filter in an enclosure, wire the input cable of the noise filter as short as possible. Wiring in long distance may reduce the noise suppressing effect.

- **Surge arrester**

A surge arrester is effective for reduction of the surge voltage of the lightning surge generated between the AC power line and earth or between AC power lines. Connect the following surge arrester.

Manufacture	Single-phase 100-115 V Single-phase 200-230 V	Three-phase 200-230 V
SOSHIN ELECTRIC CO.,LTD	LT-C12G801WS	LT-C32G801WS
OKAYA ELECTRIC INDUSTRIES CO., LTD.	R-A-V-781BWZ-4	R-A-V-781BXZ-4



When measuring dielectric strength of the equipment, be sure to remove the surge arrester, or the surge arrester may be damaged.

- **Noise suppression parts (accessories)**

Refer to p.57 for accessories.

- **Driver cable**

This cable is a shielded twisted pair cable for good noise immunity to connect the driver and controller. The ground wires useful to grounding are provided at both ends of the cable. The EMC measures are conducted using the Oriental Motor driver cable.

- **Connector-terminal block conversion unit**

This is an accessory in which I/O signals of a controller can be connected on the terminal block. The ground wires useful to grounding are provided at both ends of the cable.

- **Pulse signal converter for noise immunity**

This is a noise filter for pulse signal lines. It eliminates the noise of the pulse signal and changes the pulse signal to the line driver type.

- **Surge suppressor**

This product is effective to suppress the surge which occurs in a relay contact part. Connect it when using a relay or electromagnetic switch. CR circuit for surge suppression and CR circuit module are provided.

4-8 Installing and wiring in compliance with EMC Directive

Effective measures must be taken against the EMI that the motor and driver may give to adjacent control-system equipment, as well as the EMS of the motor and driver itself, in order to prevent a serious functional impediment in the machinery. The use of the following installation and wiring methods will enable the motor and driver to be compliant with the EMC Directive. Refer to p.166 for the applicable standards.

Oriental Motor conducts EMC measurements on its motors and drivers in accordance with "Example of motor and driver installation and wiring" on p.49.

The user is responsible for ensuring the machine's compliance with the EMC Directive, based on the installation and wiring explained below.

- **Connecting noise filter**

In large electrically noisy environments, connect a noise filter.

- **Connecting surge arrester**

Refer to "Example of motor and driver installation and wiring" on p.49.

- **Connecting the AC power line reactor**

When inputting single-phase 230 V, insert a reactor (5 A, 5 mH) in the AC power line to ensure compliance with EN 61000-3-2.

- **Connecting the 24 VDC power supply**

Use a 24 VDC power supply that conforms to the EMC Directive.

Use a shielded twisted pair cable for wiring. Refer to "Prevention of noise propagation" on p.47 for wiring method.

- **Connecting the motor cable**

Use an accessory motor cable when extending the wiring distance between the motor and driver.

- **Connecting the signal cable**

Refer to "Prevention of noise propagation" on p.47.

● **How to ground**

- The cable used to ground the motor, driver and noise filter must be as thick and short as possible so that no potential difference is generated.
- Choose a large, thick and uniformly conductive surface for the grounding point.
- Be sure to ground the Protective Earth Terminal of the motor and driver. Refer to p.44 for grounding method.

● **Example of motor and driver installation and wiring**

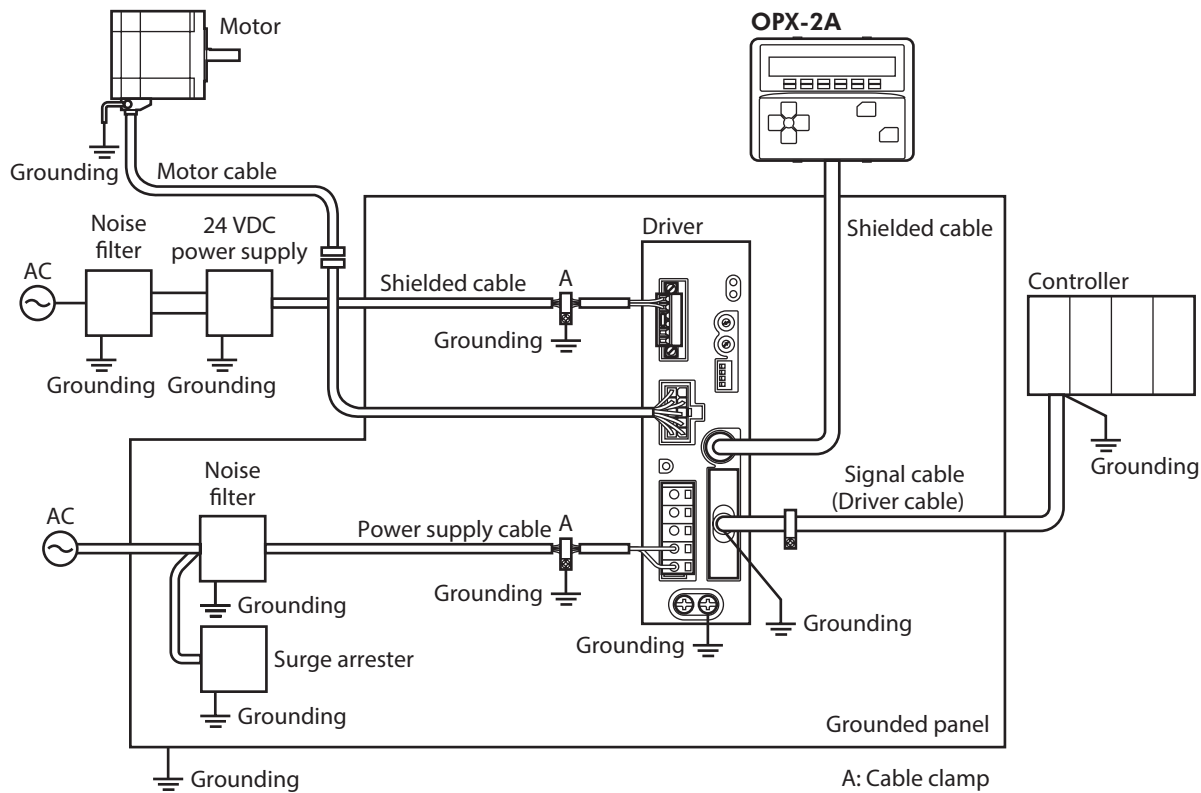

The driver uses parts that are sensitive to electrostatic charge. Take measures against static electricity since static electricity may cause the driver to malfunction or suffer damage.

5 Guidance

If you are new to the **AR** Series driver, read this chapter and you will be able to perform basic motor operations quickly.

Note Before operating the motor, check the condition of the surrounding area to ensure safety.

STEP 1 Check the connection

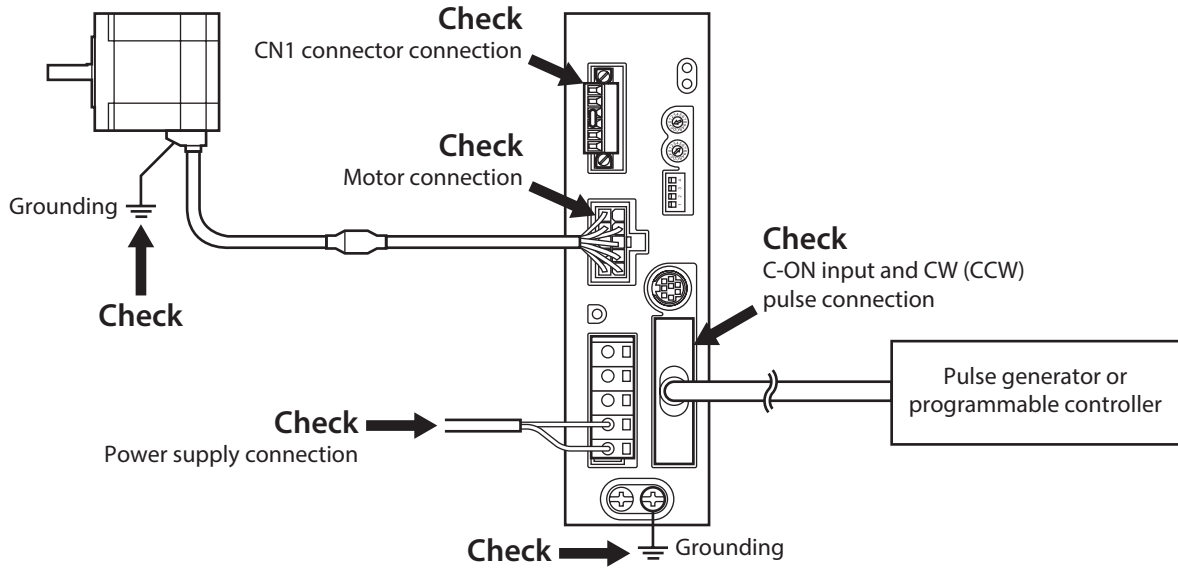

2 AC power input type

STEP 2 Set the switches

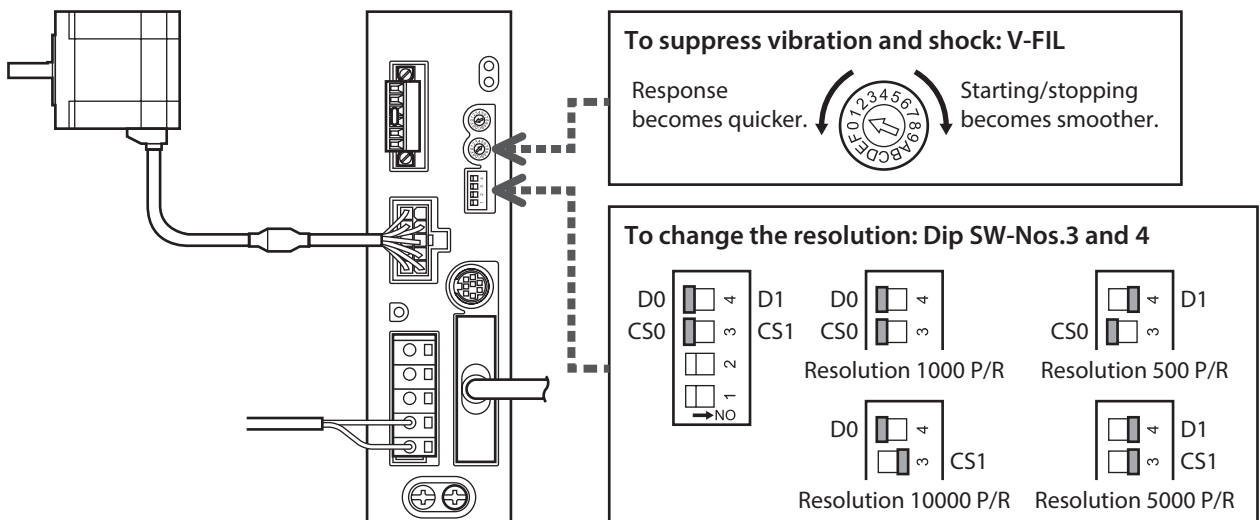

STEP 3 Turn on the power supply and check the LED

Check that the LED condition has become as shown in the figures.

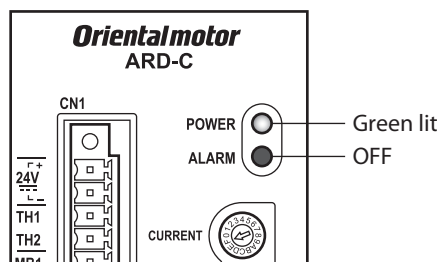

- When the ALARM LED (red) is blinking:
Count the number of times the LED blinks, and check the alarm information. (⇒ p.143)

STEP 4 Operate the motor

3. Check the motor rotates according to the setting.

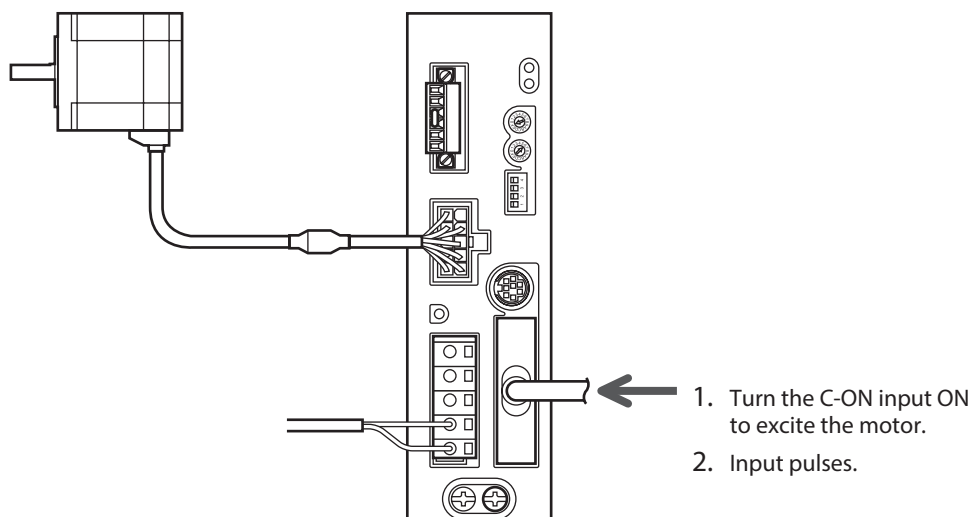

STEP 5 Were you able to operate the motor properly?

How did it go? Were you able to operate the motor properly? If the motor does not function, check the following points:

- Is the C-ON input ON?
- Are the regeneration resistor thermal input terminals (TH1 and TH2) on the CN1 shorted with a jumper wire?
- Is any alarm present?
- Are the power supply and motor connected securely?

For more detailed settings and functions, refer to "4 AC power input type/DC power input type Common" on p.95.

6 Setting

This chapter explains how to change and set the driver functions using the switches on the front face of the driver.

Note Before operating any switch, turn off the driver power and wait for the CHARGE LED to turn off. Failure to do so may cause electric shock.

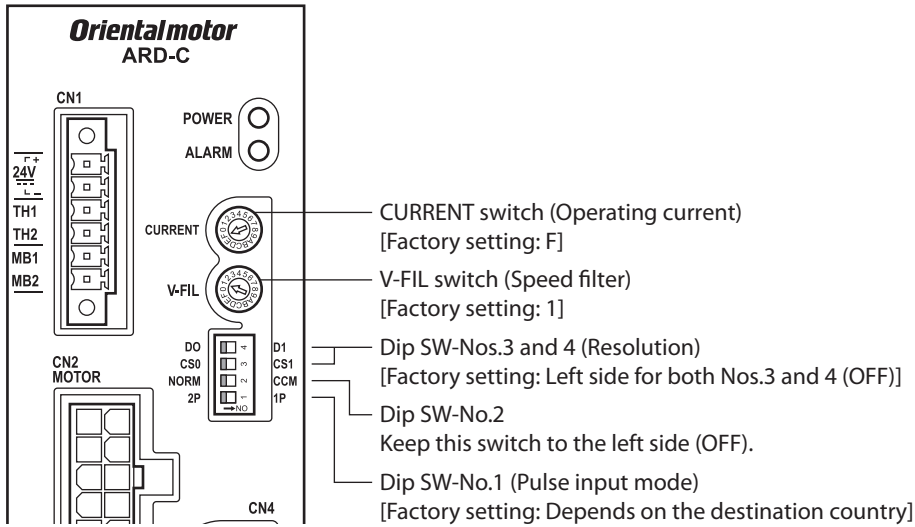

2 AC power input type

6-1 Resolution

Set a resolution when using in combination with a mechanism product such as a geared motor or an actuator. Use the Dip SW-Nos.3 and 4 to set a desired resolution per revolution of the motor output shaft.

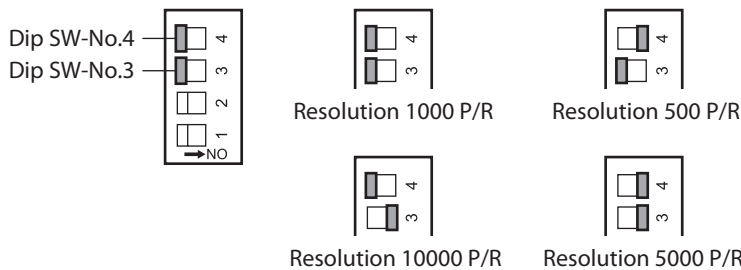

memo

- The new setting of the Dip SW will be enabled after the power is cycled. If a 24 VDC power supply is used, also cycle the 24 VDC power supply.
- When the resolution is changed with the CS input, set the Dip SW-No.3 to the left side (OFF). If the Dip SW-No.3 is set to the right side (ON), the resolution will not change even when the CS input is turned ON.

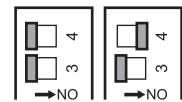

- To change the basic setting for resolution: Refer to p.107.

6-2 Pulse input mode

Set a desired pulse input mode of the driver according to the pulse output mode of the controller (pulse generator) used with the driver. Set a desired mode using the Dip SW-No.1.

Dip SW-No.1 is set to the right side (ON): 1-pulse input mode (when the PLS input and DIR input are used)

Dip SW-No.1 is set to the left side (OFF): 2-pulse input mode (when the CW input and CCW input are used)

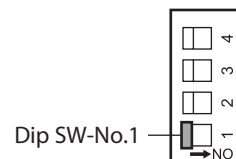

The new setting of the Dip SW will be enabled after the power is cycled. If a 24 VDC power supply is used, also cycle the 24 VDC power supply.

- To change the basic setting for pulse input mode: Refer to p.109.

6-3 Operating current

Set a desired operating current using the CURRENT switch.

The operating current to be set is the maximum output current multiplied by the operating current rate (%) set to each dial setting of the current setting switch, where "F" corresponds to 100%.

One of 16 operating current levels from 0 to F can be set. If the load is small and there is an ample allowance for torque, motor temperature rise can be suppressed by setting a lower operating current.

The dial settings and corresponding operating current rates are listed below.

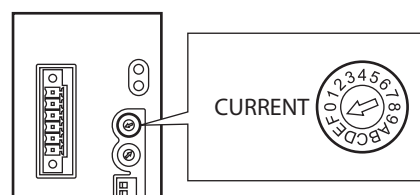

Dial setting	Operating current rate (%)	Dial setting	Operating current rate (%)
0	6.3	8	56.3
1	12.5	9	62.5
2	18.8	A	68.8
3	25.0	B	75.0
4	31.3	C	81.3
5	37.5	D	87.5
6	43.8	E	93.8
7	50.0	F	100 (factory setting)



Excessively low operating current may cause a problem in starting the motor or holding the load in position. Do not lower the operating current more than necessary.

- To change the basic setting for operating current: Refer to p.122.

6-4 Speed filter

The motor response to input pulses can be adjusted with the V-FIL switch. One of 16 speed filter levels from 0 to F can be set. When setting a higher value for the speed filter, lower vibration at low speed operation or smoother operation at starting/stopping of the motor can be achieved. However, if this setting is too high, synchronization performance is decreased. Set a suitable value based on the load or application.

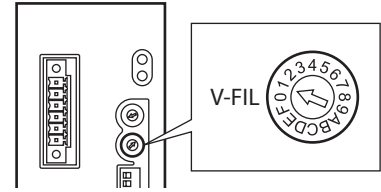

Dial setting	Speed filter time constant (ms)
0	0
1	1 (factory setting)
2	2
3	3
4	5
5	7
6	10
7	20

Dial setting	Speed filter time constant (ms)
8	30
9	50
A	70
B	100
C	120
D	150
E	170
F	200

- When the V-FIL switch is set to 0 (minimum)

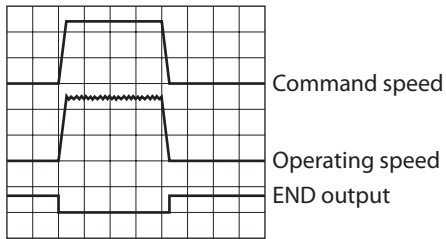

- When the V-FIL switch is set to F (maximum)

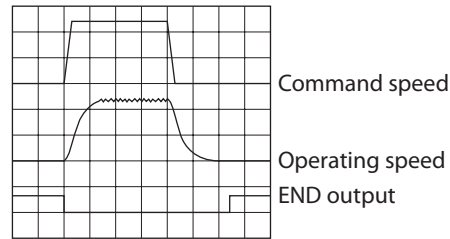

- To change the basic setting for speed filter: Refer to p.123.

7 Accessories

7-1 Motor cable set

■ Connection cable set

Use when connecting a motor and a driver.

The cable set for electromagnetic brake motors consists of two cables, one for motor and the other for electromagnetic brake.

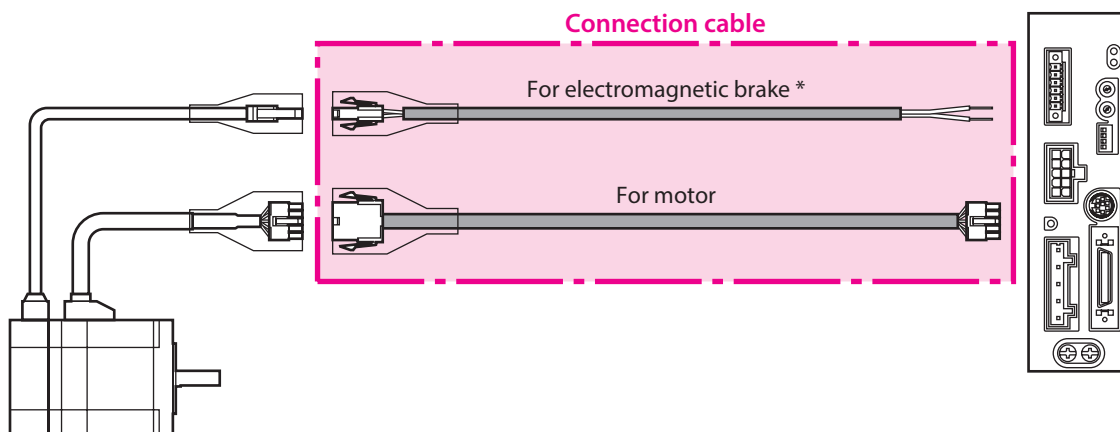

* Only when the motor is of electromagnetic brake type.

memo When installing the motor on a moving part, use a flexible cable having excellent flex resistance.

● Connection cable set For standard type motor

Model	Length [m (ft.)]
CC010VAF	1 (3.3)
CC020VAF	2 (6.6)
CC030VAF	3 (9.8)
CC050VAF	5 (16.4)
CC070VAF	7 (23)
CC100VAF	10 (32.8)
CC150VAF	15 (49.2)
CC200VAF	20 (65.6)
CC300VAF	30 (98.4)

● Connection cable set For electromagnetic brake type motor

Model	Length [m (ft.)]
CC010VAFB	1 (3.3)
CC020VAFB	2 (6.6)
CC030VAFB	3 (9.8)
CC050VAFB	5 (16.4)
CC070VAFB	7 (23)
CC100VAFB	10 (32.8)
CC150VAFB	15 (49.2)
CC200VAFB	20 (65.6)
CC300VAFB	30 (98.4)

2 AC power input type

● Flexible connection cable set
For standard type motor

Model	Length [m (ft.)]
CC010VAR	1 (3.3)
CC020VAR	2 (6.6)
CC030VAR	3 (9.8)
CC050VAR	5 (16.4)
CC070VAR	7 (23)
CC100VAR	10 (32.8)
CC150VAR	15 (49.2)
CC200VAR	20 (65.6)
CC300VAR	30 (98.4)

● Flexible connection cable set
For electromagnetic brake type motor

Model	Length [m (ft.)]
CC010VARB	1 (3.3)
CC020VARB	2 (6.6)
CC030VARB	3 (9.8)
CC050VARB	5 (16.4)
CC070VARB	7 (23)
CC100VARB	10 (32.8)
CC150VARB	15 (49.2)
CC200VARB	20 (65.6)
CC300VARB	30 (98.4)

■ Extension cable set

Use when extending the distance between a motor and a driver or when the length of the connection cable used is not enough. Extend the distance by connecting the extension cable to the connection cable. The cable set for electromagnetic brake motors consists of two cables, one for motor and the other for electromagnetic brake.

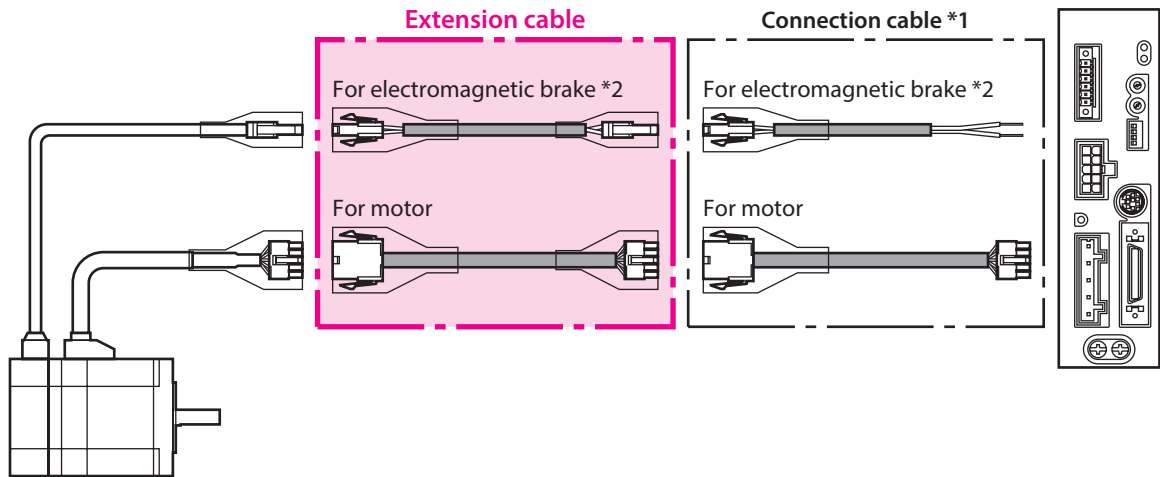

*1 Use the connection cable used.

*2 Only when the motor is of electromagnetic brake type.

- memo**
- When installing the motor on a moving part, use a flexible cable having excellent flex resistance.
 - When extending the wiring length by connecting an extension cable to the connection cable, keep the total cable length to 30 m (98.4 ft.) or less.

● Extension cable set
For standard type motor

Model	Length [m (ft.)]
CC010VAFT	1 (3.3)
CC020VAFT	2 (6.6)
CC030VAFT	3 (9.8)
CC050VAFT	5 (16.4)
CC070VAFT	7 (23)
CC100VAFT	10 (32.8)
CC150VAFT	15 (49.2)
CC200VAFT	20 (65.6)

● Extension cable set
For electromagnetic brake type motor

Model	Length [m (ft.)]
CC010VAFBT	1 (3.3)
CC020VAFBT	2 (6.6)
CC030VAFBT	3 (9.8)
CC050VAFBT	5 (16.4)
CC070VAFBT	7 (23)
CC100VAFBT	10 (32.8)
CC150VAFBT	15 (49.2)
CC200VAFBT	20 (65.6)

- **Flexible extension cable set**
For standard type motor

Model	Length [m (ft.)]
CC010VART	1 (3.3)
CC020VART	2 (6.6)
CC030VART	3 (9.8)
CC050VART	5 (16.4)
CC070VART	7 (23)
CC100VART	10 (32.8)
CC150VART	15 (49.2)
CC200VART	20 (65.6)

- **Flexible extension cable set**
For electromagnetic brake type motor

Model	Length [m (ft.)]
CC010VARBT	1 (3.3)
CC020VARBT	2 (6.6)
CC030VARBT	3 (9.8)
CC050VARBT	5 (16.4)
CC070VARBT	7 (23)
CC100VARBT	10 (32.8)
CC150VARBT	15 (49.2)
CC200VARBT	20 (65.6)

7-2 Setting tool

■ Communication cable for the support software

Be sure to purchase the communication cable for the support software when connecting a driver and PC in which the support software **MEXE02** has been installed.

This is a set of a PC interface cable and USB cable. The cable is connected to the USB port on the PC.

Model: **CC05IF-USB** [5 m (16.4 ft.)]

The **MEXE02** can be downloaded from Oriental Motor Website Download Page. Also, the **MEXE02** is provided in the form of a storage medium. For details, check out our web site or contact your nearest Oriental Motor sales office.

■ Data setter

The data setter lets you set parameters for your **AR** Series with ease and also functions as a monitor.

Model: **OPX-2A**

7-3 Wiring support tool

■ Regeneration resistor

Connect the regeneration resistor if gravitational operation or other operations involving up/down movement, or sudden starting/stopping of a large inertial load, will be repeated frequently. Always connect the regeneration resistor if an overvoltage protection warning or alarm generates.

Model: **RGB100**

■ Driver cable

A shielded cable for driver I/O signals (36 pins) offering excellent noise resistance.

The ground wires useful to grounding are provided at both ends of the cable.

Model	Connector type	Length [m (ft.)]
CC36D1E	Straight	1 (3.3)
CC36D2E		2 (6.6)
CC36D1AE	Right Angle	1 (3.3)
CC36D2AE		2 (6.6)

■ Connector-terminal block conversion unit

The driver and programmable controller can be connected on the terminal block.
A shielded cable is used. The ground wires useful to grounding are provided at both ends of the cable.

Model	Connector type	Length [m (ft.)]
CC36T10E	Single-row	1 (3.3)
CC36WT05AE	2 rows	0.5 (1.6)
CC36WT10AE		1 (3.3)

■ Pulse signal converter for noise immunity

It eliminates the noise of the pulse signal and changes the pulse signal to the line driver type.

Model: **VCS06**

■ CR circuit for surge suppression

This product is effective to suppress the surge which occurs in a relay contact part. Use it to protect the contacts of the relay or switch.

Model: **EPCR1201-2**

■ CR circuit module

This product is effective to suppress the surge which occurs in a relay contact part. Use this product to protect the contacts of the relay or switch.

4 pieces of CR circuit for surge suppression are mounted on the compact circuit, and this product can be installed to the DIN rail. This product can make the wiring easily and securely since it also supports terminal block connection.

Model: **VCS02**

3 DC power input type

This part explains contents specific to the AR Series DC power input type.

◆Table of contents

1	System configuration.....	60		
2	Preparation	61		
	2-1 Checking the product	61		
	2-2 How to identify the product model	62		
	2-3 Information about nameplate	63		
	2-4 Combinations of motors and drivers.....	63		
	2-5 Input/output power ratings.....	65		
	2-6 Names and functions of parts.....	65		
3	Installation	68		
	3-1 Location for installation.....	68		
	3-2 Installing the motor	68		
	3-3 Installing a load	69		
	3-4 Permissible radial load and permissible axial load.....	70		
	3-5 Installing the driver.....	72		
4	Connection	74		
	4-1 Connection example	74		
	4-2 Connecting the I/O signals.....	75		
	4-3 Connecting the power supply and grounding the driver	82		
	4-4 Grounding the motor.....	83		
	4-5 Connecting the data setter	83		
	4-6 Noise measures	83		
	4-7 Conformity to the EMC Directive	85		
5	Guidance	86		
6	Setting	88		
	6-1 Resolution	88		
	6-2 Pulse input mode.....	88		
	6-3 Operating current.....	89		
	6-4 Speed filter	89		
7	Accessories.....	91		
	7-1 Motor cable set.....	91		
	7-2 Setting tool	93		
	7-3 Wiring support tool.....	93		

1 System configuration

With the **AR** Series pulse input type, all you need to do in order to operate the motor is to turn the C-ON input ON and input pulses.

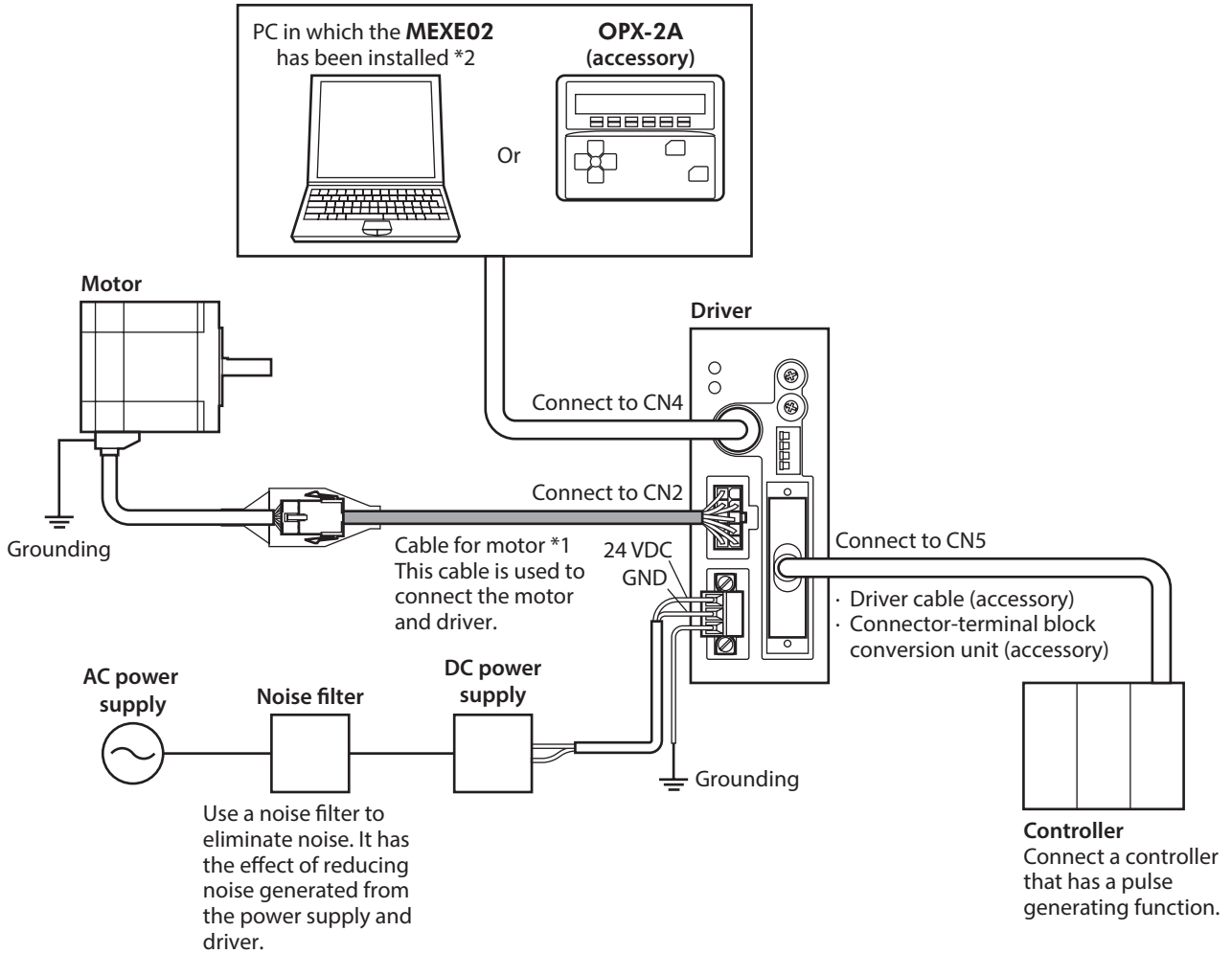

*1 Cables represented in gray color are supplied with the product or sold separately.

*2 The PC must be supplied by the user. Use the accessory communication cable for the support software when connecting the PC and driver.

2 Preparation

This chapter explains the items you should check, as well as the name and function of each part.

2-1 Checking the product

Verify that the items listed below are included. Report any missing or damaged items to the Oriental Motor sales office from which you purchased the product.

Verify the model number of the purchased unit against the number shown on the package label.

Check the model number of the motor and driver against the number shown on the nameplate. Refer to p.63 for how to identify the nameplate.

The motor and driver package names and corresponding motor/driver combinations are listed on p.63.

- Motor 1 unit
- Driver 1 unit
- CN1 connector (3 pins)..... 1 pc.
- CN5 connector (36 pins) 1 pc.
- OPERATING MANUAL Motor..... 1 copy
- OPERATING MANUAL Driver..... 1 copy
- APPENDIX UL Standards for **AR** Series..... 1 copy
- Cable for motor 1 pc. *1
- Cable for electromagnetic brake 1 pc. *1 *2
- Parallel key 1 pc. *3
- Varistor 1 pc. *2

*1 When the product is supplied with a connection cable.

*2 Supplied with electromagnetic brake type.

*3 Supplied with geared types; except for the **AR24**, **AR46TH** and **AR66TH**.

Supplied connector model

Type	Model number	Manufacturer
CN1 connector	MC1,5/3-STF-3,5	PHOENIX CONTACT GmbH & Co. KG
CN5 connector	Case: 10336-52A0-008	3M Japan Limited
	Connector: 10136-3000PE	3M Japan Limited

2-2 How to identify the product model

- Standard type

AR 2 4 S A K -1
 1 2 3 4 5 6 9

- Geared type

AR 4 6 S A K - PS 10 -2
 1 2 3 4 5 6 7 8 9

1	Series name	AR Series
2	Motor frame size	1: 20 mm (0.79 in.) 2: 28 mm (1.10 in.) [30 mm (1.18 in.) for Harmonic geared type] 4: 42 mm (1.65 in.) 6: 60 mm (2.36 in.) 9: 85 mm (3.35 in.) [90 mm (3.54 in.) for geared type]
3	Motor length	
4	Motor identification	S: Without connector cover for cable Blank: With connector cover for cable
5	Motor type	A: Single shaft B: Double shaft M: With electromagnetic brake
6	Power supply voltage	K: 24 VDC/48 VDC
7	Type of gear	T: TH geared type PS: PS geared type N: PN geared type H: Harmonic geared type Blank: Standard type
8	Gear ratio	Indicates a number representing the gear ratio. Refer to the table below for the gear type and gear ratio.
9	Length of connection cable	Number: Length of supplied connection cable (m) Blank: Without connection cable

Type of gear ratio

Type of gear	Gear ration
TH geared type	AR24: 7.2, 10, 20, 30 AR46, AR66, AR98: 3.6, 7.2, 10, 20, 30
PS geared type	AR24: 5, 7.2 (*), 10 AR46, AR66, AR98: 5, 7.2 (*), 10, 25, 36, 50
PN geared type	AR24, AR46: 5, 7.2, 10 AR66, AR98: 5, 7.2, 10, 25, 36, 50
Harmonic geared type	50, 100

* The model name is "7" for the gear ratio 7.2 of the **PS** geared type.

2-3 Information about nameplate

The figure shows an example.

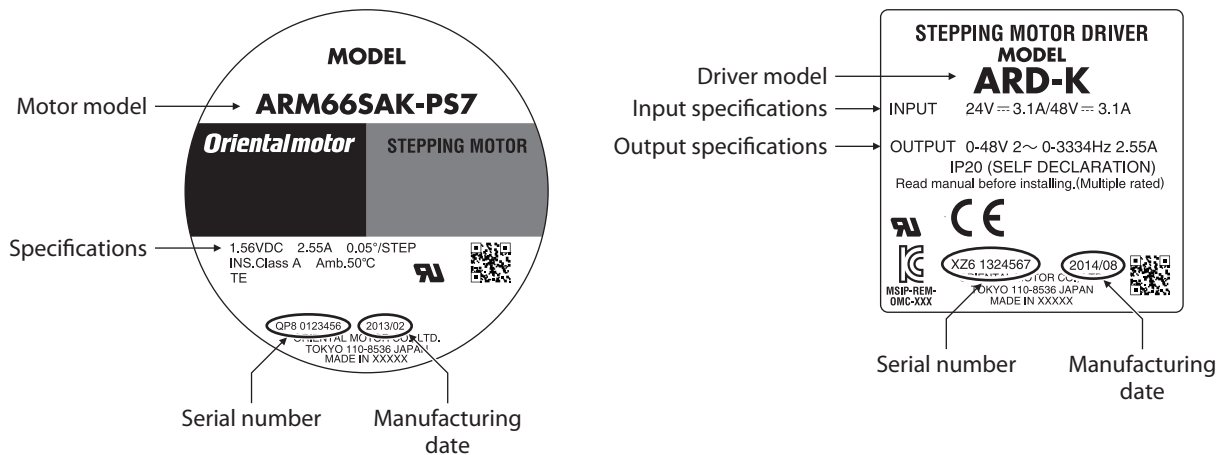

memo The position describing the information may vary depending on the product.

2-4 Combinations of motors and drivers

- ■ in the model names represents a number indicating the gear ratio.
- ○ in the model names represents the cable length (-1, -2, -3) when the connection cable is supplied.

■ Standard type

● Single shaft

Model	Motor model	Driver model
AR14SAK○	ARM14SAK	ARD-K
AR15SAK○	ARM15SAK	
AR24SAK○	ARM24SAK	
AR26SAK○	ARM26SAK	
AR46SAK○	ARM46SAK	
AR46AK○	ARM46AK	
AR66SAK○	ARM66SAK	
AR66AK○	ARM66AK	
AR69SAK○	ARM69SAK	
AR69AK○	ARM69AK	
AR98SAK○	ARM98SAK	
AR98AK○	ARM98AK	

● Double shaft

Model	Motor model	Driver model
AR14SBK○	ARM14SBK	ARD-K
AR15SBK○	ARM15SBK	
AR24SBK○	ARM24SBK	
AR26SBK○	ARM26SBK	
AR46SBK○	ARM46SBK	
AR46BK○	ARM46BK	
AR66SBK○	ARM66SBK	
AR66BK○	ARM66BK	
AR69SBK○	ARM69SBK	
AR69BK○	ARM69BK	
AR98SBK○	ARM98SBK	
AR98BK○	ARM98BK	

● With electromagnetic brake

Model	Motor model	Driver model
AR24SMK○	ARM24SMK	ARD-K
AR26SMK○	ARM26SMK	
AR46SMK○	ARM46SMK	
AR46MK○	ARM46MK	
AR66SMK○	ARM66SMK	

Model	Motor model	Driver model
AR66MK○	ARM66MK	ARD-K
AR69SMK○	ARM69SMK	
AR69MK○	ARM69MK	
AR98SMK○	ARM98SMK	
AR98MK○	ARM98MK	

■ TH geared type

● Single shaft

Model	Motor model	Driver model
AR24SAK-T■○	ARM24SAK-T■	ARD-K
AR46SAK-T■○	ARM46SAK-T■	
AR46AK-T■○	ARM46AK-T■	
AR66SAK-T■○	ARM66SAK-T■	
AR66AK-T■○	ARM66AK-T■	
AR98SAK-T■○	ARM98SAK-T■	
AR98AK-T■○	ARM98AK-T■	

● With electromagnetic brake

Model	Motor model	Driver model
AR24SMK-T■○	ARM24SMK-T■	ARD-K
AR46SMK-T■○	ARM46SMK-T■	
AR46MK-T■○	ARM46MK-T■	
AR66SMK-T■○	ARM66SMK-T■	
AR66MK-T■○	ARM66MK-T■	
AR98SMK-T■○	ARM98SMK-T■	
AR98MK-T■○	ARM98MK-T■	

■ PN geared type

● Single shaft

Model	Motor model	Driver model
AR24SAK-N■○	ARM24SAK-N■	ARD-K
AR46SAK-N■○	ARM46SAK-N■	
AR46AK-N■○	ARM46AK-N■	
AR66SAK-N■○	ARM66SAK-N■	
AR66AK-N■○	ARM66AK-N■	
AR98SAK-N■○	ARM98SAK-N■	
AR98AK-N■○	ARM98AK-N■	

● With electromagnetic brake

Model	Motor model	Driver model
AR46SMK-N■○	ARM46SMK-N■	ARD-K
AR46MK-N■○	ARM46MK-N■	
AR66SMK-N■○	ARM66SMK-N■	
AR66MK-N■○	ARM66MK-N■	
AR98SMK-N■○	ARM98SMK-N■	
AR98MK-N■○	ARM98MK-N■	

■ PS geared type

● Single shaft

Model	Motor model	Driver model
AR24SAK-PS■○	ARM24SAK-PS■	ARD-K
AR46SAK-PS■○	ARM46SAK-PS■	
AR46AK-PS■○	ARM46AK-PS■	
AR66SAK-PS■○	ARM66SAK-PS■	
AR66AK-PS■○	ARM66AK-PS■	
AR98SAK-PS■○	ARM98SAK-PS■	
AR98AK-PS■○	ARM98AK-PS■	

● With electromagnetic brake

Model	Motor model	Driver model
AR46SMK-PS■○	ARM46SMK-PS■	ARD-K
AR46MK-PS■○	ARM46MK-PS■	
AR66SMK-PS■○	ARM66SMK-PS■	
AR66MK-PS■○	ARM66MK-PS■	
AR98SMK-PS■○	ARM98SMK-PS■	
AR98MK-PS■○	ARM98MK-PS■	

■ Harmonic geared type

● Single shaft

Model	Motor model	Driver model
AR24SAK-H■○	ARM24SAK-H■	ARD-K
AR46SAK-H■○	ARM46SAK-H■	
AR46AK-H■○	ARM46AK-H■	
AR66SAK-H■○	ARM66SAK-H■	
AR66AK-H■○	ARM66AK-H■	
AR98SAK-H■○	ARM98SAK-H■	
AR98AK-H■○	ARM98AK-H■	

● With electromagnetic brake

Model	Motor model	Driver model
AR24SMK-H■○	ARM24SMK-H■	ARD-K
AR46SMK-H■○	ARM46SMK-H■	
AR46MK-H■○	ARM46MK-H■	
AR66SMK-H■○	ARM66SMK-H■	
AR66MK-H■○	ARM66MK-H■	
AR98SMK-H■○	ARM98SMK-H■	
AR98MK-H■○	ARM98MK-H■	

2-5 Input/output power ratings

- in the model names represents **A** (single shaft), **B** (double shaft), or **M** (with electromagnetic brake).
 For the **AR14** and **AR15** standard type, ■ represents **A** (single shaft) or **B** (double shaft).
 For the geared type, ■ represents **A** (single shaft) or **M** (with electromagnetic brake).
 For the **AR24** of **PN** geared type and **PS** geared type, ■ represents **A** (single shaft).
- For geared type, ● in the model names represents the type of gear and number indicating the gear ratio.
- in the model names represents the cable length (-1, -2, -3) when the connection cable is supplied.

Model	Motor model	Driver model	Input		Output current per phase
			Voltage	Current	
AR14S ■K□	ARM14S■K	ARD-K	24 VDC	0.4 A	0.43 A
AR15S ■K□	ARM15S■K			0.5 A	0.52 A
AR24S ■K●□	ARM24S■K●			0.9 A	0.88 A
AR26S ■K□	ARM26S■K		24 VDC 48 VDC	1.4 A	1.48 A
AR46S ■K●□	ARM46S■K●			3.1 A	2.55 A
AR46 ■K●□	ARM46■K●				
AR66S ■K●□	ARM66S■K●			3.0 A	2.55 A
AR66 ■K●□	ARM66■K●				
AR69S ■K□	ARM69S■K			2.5 A	2.55 A
AR69 ■K□	ARM69■K				
AR98S ■K●□	ARM98S■K●				
AR98 ■K●□	ARM98■K●				

2-6 Names and functions of parts

■ Motor (Example: ARM66SMK)

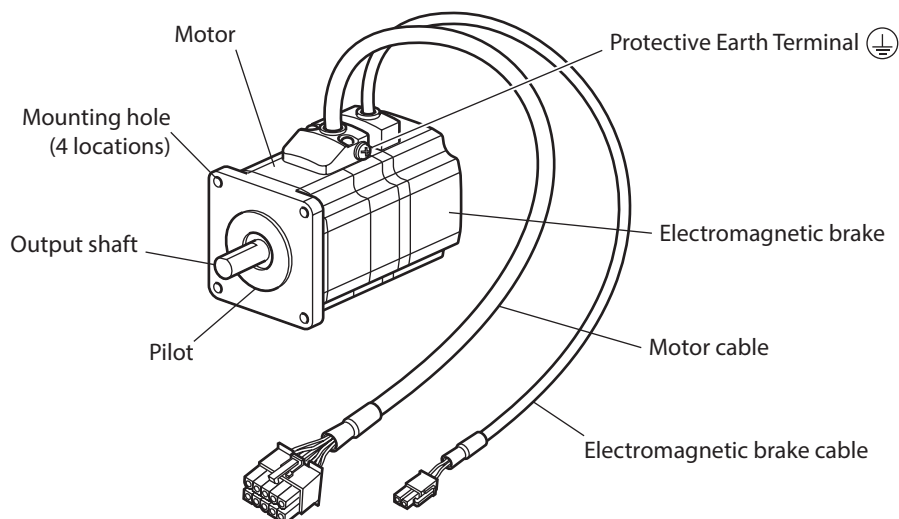

■ Driver

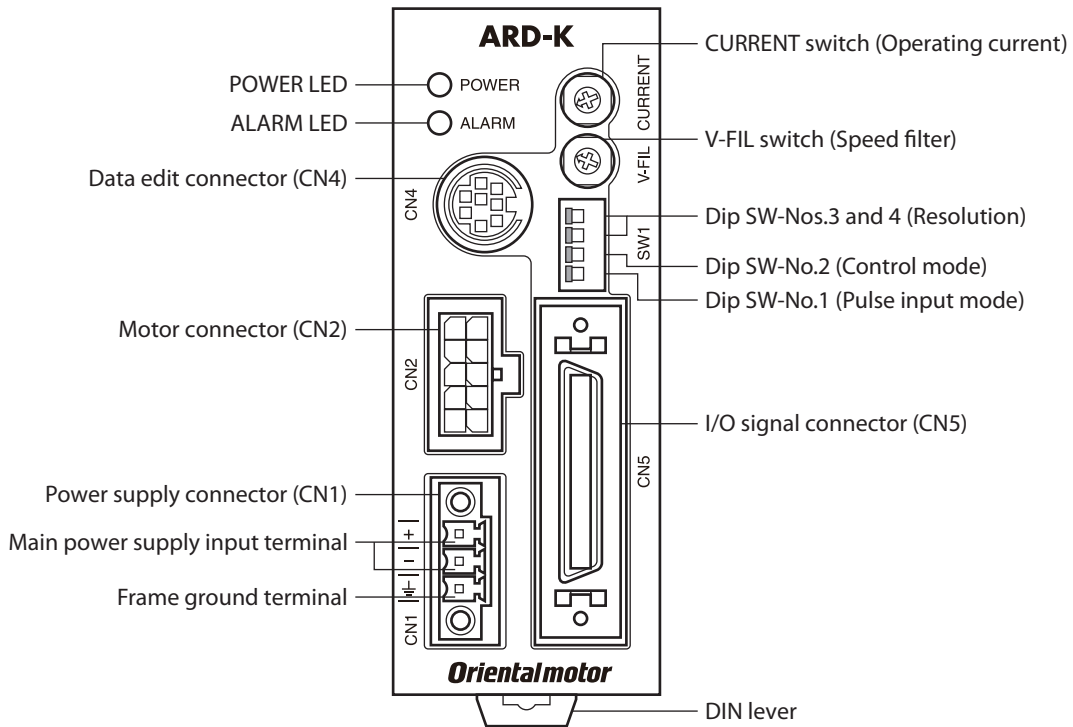

3 DC power input type

Name	Description	Page
POWER LED (Green)	This LED is lit while the main power is input.	-
ALARM LED (Red)	This LED will blink when an alarm generates. It is possible to check the generated alarm by counting the number of times the LED blinks.	p.142
Main power supply input terminal (CN1)	Connects the main power supply.	p.82
Frame ground terminal (CN1)	Used for grounding via a grounding cable of AWG24 to 16 (0.2 to 1.25 mm ²).	
Motor connector (CN2)	Connects the motor.	p.74
Data edit connector (CN4)	Connects a PC in which the MEXE02 has been installed, or the OPX-2A .	p.83
I/O signal connector (CN5)	Connects the I/O signals of the controller.	p.75
CURRENT switch (Operating current)	This switch adjusts the operating current. It is used to limit the torque and temperature rise. A desired current can be set as a percentage (%) of the rated output current. Factory setting: F	p.89
V-FIL switch (Speed filter)	This switch adjusts the motor response. Use this switch if you want to suppress motor vibration or cause the motor to start/stop smoothly. "0" and "F" correspond to the minimum and maximum speed filter settings, respectively. Factory setting: 1	p.89
Dip SW-No.1 (Pulse input mode)	This switch is used to toggle between the 1-pulse input mode and 2-pulse input mode according to the pulse output mode of the controller. Left side (OFF): 2-pulse input mode, active low Right side (ON): 1-pulse input mode, active low The factory setting of the pulse-input mode depends on the destination country.	p.88

Name	Description	Page
Dip SW-No.2 (Control mode)	<p>This switch toggles the driver between the normal mode and current control mode.</p> <p>Left side (OFF): Normal mode (Keep the switch in this position in normal conditions of use.)</p> <p>Right side (ON): Current control mode (Set the switch to this position if you want to suppress noise or vibration.)</p> <p>Factory setting: Left side (OFF) [Normal mode]</p>	p.122
Dip SW-Nos.3 and 4 (Resolution)	<p>These two switches are used to set the resolution per revolution of the motor output shaft.</p> <p>Factory setting: No.3 and No.4 are both left side (OFF) [1000 P/R]</p>	p.88
DIN lever	Install the driver to a DIN rail	p.72

3 Installation

This chapter explains the installation location and installation methods of the motor and driver.

3-1 Location for installation

The motor and driver are designed and manufactured to be incorporated in equipment. Install them in a well-ventilated location that provides easy access for inspection.

The location must also satisfy the following conditions:

- Inside an enclosure that is installed indoors (provide vent holes)
- Operating ambient temperature
 - Motor: -10 to +50 °C (+14 to +122 °F) (non-freezing)
 - Harmonic geared type: 0 to +40 °C (+32 to +104 °F) (non-freezing)
 - Driver: 0 to +50 °C (+32 to +122 °F) (non-freezing)
- Operating ambient humidity 85% or less (non-condensing)
- Area that is free of explosive atmosphere or toxic gas (such as sulfuric gas) or liquid
- Area not exposed to direct sun
- Area free of excessive amount of dust, iron particles or the like
- Area not subject to splashing water (rain, water droplets), oil (oil droplets) or other liquids
- Area free of excessive salt
- Area not subject to continuous vibration or excessive shocks
- Area free of excessive electromagnetic noise (from welders, power machinery, etc.)
- Area free of radioactive materials, magnetic fields or vacuum
- 1000 m (3300 ft.) or lower above sea level

3-2 Installing the motor

The motor can be installed in any direction.

To allow for heat dissipation and prevent vibration, install the motor on a metal surface of sufficient strength.

● **Installation method A**

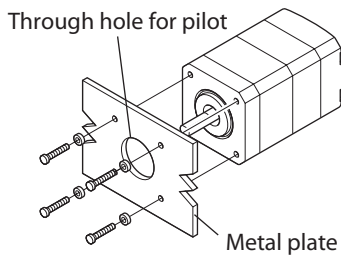

● **Installation method B**

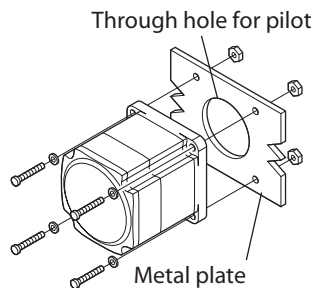

Type	Frame size [mm (in.)]	Bolt size	Tightening torque [N·m (oz-in)]	Effective depth of screw thread [mm (in.)]	Installation method
Standard	20 (0.79)	M2	0.25 (35)	2.5 (0.098)	A
	28 (1.10)	M2.5	0.5 (71)	2.5 (0.098)	
	42 (1.65)	M3	1 (142)	4.5 (0.177)	
	60 (2.36)	M4	2 (280)	-	B
	85 (3.35)	M6	3 (420)	-	
TH geared	28 (1.10)	M2.5	0.5 (71)	4 (0.157)	A
	42 (1.65)	M4	2 (280)	8 (0.315)	
	60 (2.36)	M4	2 (280)	8 (0.315)	
	90 (3.54)	M8	4 (560)	15 (0.591)	

Type	Frame size [mm (in.)]	Bolt size	Tightening torque [N·m (oz-in)]	Effective depth of screw thread [mm (in.)]	Installation method
PN geared PS geared Harmonic geared *1	28 (1.10) 30 (1.18)	M3	1 (142)	6 (0.236)	A
	42 (1.65)	M4	2 (280)	8 (0.315)	
	60 (2.36)	M5	2.5 (350)	10 (0.394)	
	90 (3.54)	M8	4 (560)	15 (0.591)	
Harmonic geared *2	90 (3.54)	M8	4 (560)	–	B

*1 **AR24**, **AR46** and **AR66** type only.

*2 **AR98** type only.

3-3 Installing a load

When connecting a load to the motor, align the centers of the motor output shaft and load shaft. Flexible couplings are available as accessories.

Note

- When coupling the load to the motor, pay attention to the centering of the shafts, belt tension, parallelism of the pulleys, and so on. Securely tighten the coupling and pulley set screws.
- Be careful not to damage the output shaft or bearings when installing a coupling or pulley to the motor output shaft.
- Do not modify or machine the motor output shaft. Doing so may damage the bearings and destroy the motor.
- Do not apply strong force using hammer or other tools when removing the parallel key. Doing so may damage the motor output shaft and bearings (ball bearings).

● Using a coupling

Align the centers of the motor output shaft and load shaft in a straight line.

● Using a belt drive

Align the motor output shaft and load shaft in parallel with each other, and position both pulleys so that the line connecting their centers is at a right angle to the shafts.

● Using a gear drive

Align the motor output shaft and gear shaft in parallel with each other, and let the gears mesh at the center of the tooth widths.

• Using a coupling

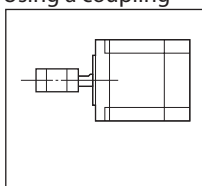

• Using a belt drive

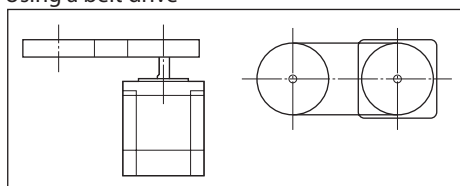

• Using a gear drive

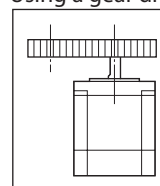

● Using a parallel key (geared motor)

When connecting the load and gear output shaft with a key slot, secure the load using the key supplied with the gear output shaft after machining the key slot on the load.

● Harmonic geared type; Installing the load on the flange surface

With a Harmonic geared type (excluding **AR98**), a load can be installed directly to the gear using the load mounting holes provided on the flange surface.

Model	Bolt size	Number of bolts	Tightening torque [N·m (oz-in)]	Effective depth of screw thread [mm (in.)]
AR24	M3	4	1.4 (198)	4 (0.157)
AR46	M3	6	1.4 (198)	5 (0.197)
AR66	M4	6	2.5 (350)	6 (0.236)

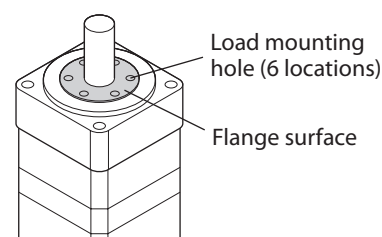



- When installing a load on the flange surface, the load cannot be mounted using the key slot in the output shaft.
- Design an appropriate installation layout so that the load will not contact the metal plate or bolts used for installing the motor.

3-4 Permissible radial load and permissible axial load



- If the radial load or axial load exceeds the specified allowable value, repeated load applications may cause the bearing (ball bearings) or output shaft of the motor to undergo a fatigue failure.
- With a double shaft type, do not apply load torque, radial load or axial load to the output shaft on the opposite side of the motor output shaft.



The permissible radial load and permissible axial load of the **PS** geared type and **PN** geared type represent the value that the service life of the gear part satisfies 20,000 hours when either of the radial load or axial load is applied to the gear output shaft.

3 DC power input type

Type	Model	Gear ratio	Permissible radial load [N (lb.)]					Permissible axial load [N (lb.)]
			Distance from the tip of motor output shaft [mm (in.)]					
			0 (0)	5 (0.2)	10 (0.39)	15 (0.59)	20 (0.79)	
Standard	AR14 AR15	-	12 (2.7)	15 (3.3)	-	-	-	3 (0.67)
	AR24 AR26		25 (5.6)	34 (7.6)	52 (11.7)	-	-	5 (1.12)
	AR46		35 (7.8)	44 (9.9)	58 (13)	85 (19.1)	-	15 (3.3)
	AR66 AR69		90 (20)	100 (22)	130 (29)	180 (40)	270 (60)	30 (6.7)
	AR98		260 (58)	290 (65)	340 (76)	390 (87)	480 (108)	60 (13.5)
TH geared	AR24	All gear ratio	15 (3.3)	17 (3.8)	20 (4.5)	23 (5.1)	-	10 (2.2)
	AR46		10 (2.2)	14 (3.1)	20 (4.5)	30 (6.7)	-	15 (3.3)
	AR66		70 (15.7)	80 (18)	100 (22)	120 (27)	150 (33)	40 (9)
	AR98		220 (49)	250 (56)	300 (67)	350 (78)	400 (90)	100 (22)
PS geared	AR24	All gear ratio	45 (10.1)	60 (13.5)	80 (18)	100 (22)	-	40 (9)
	AR46	5	70 (15.7)	80 (18)	95 (21)	120 (27)	-	100 (22)
		7.2	80 (18)	90 (20)	110 (24)	140 (31)	-	
		10	85 (19.1)	100 (22)	120 (27)	150 (33)	-	
		25	120 (27)	140 (31)	170 (38)	210 (47)	-	
		36	130 (29)	160 (36)	190 (42)	240 (54)	-	
		50	150 (33)	170 (38)	210 (47)	260 (58)	-	
	AR66	5	170 (38)	200 (45)	230 (51)	270 (60)	320 (72)	200 (45)
		7.2	200 (45)	220 (49)	260 (58)	310 (69)	370 (83)	
		10	220 (49)	250 (56)	290 (65)	350 (78)	410 (92)	
		25	300 (67)	340 (76)	400 (90)	470 (105)	560 (126)	
		36	340 (76)	380 (85)	450 (101)	530 (119)	630 (141)	
		50	380 (85)	430 (96)	500 (112)	600 (135)	700 (157)	
	AR98	5	380 (85)	420 (94)	470 (105)	540 (121)	630 (141)	600 (135)
		7.2	430 (96)	470 (105)	530 (119)	610 (137)	710 (159)	
		10	480 (108)	530 (119)	590 (132)	680 (153)	790 (177)	
		25	650 (146)	720 (162)	810 (182)	920 (200)	1070 (240)	
		36	730 (164)	810 (182)	910 (200)	1040 (230)	1210 (270)	
50		820 (184)	910 (200)	1020 (220)	1160 (260)	1350 (300)		

Type	Model	Gear ratio	Permissible radial load [N (lb.)]					Permissible axial load [N (lb.)]	
			Distance from the tip of motor output shaft [mm (in.)]						
			0 (0)	5 (0.2)	10 (0.39)	15 (0.59)	20 (0.79)		
PN geared	AR24	All gear ratio	45 (10.1)	60 (13.5)	80 (18)	100 (22)	–	40 (9)	
		AR46	5	80 (18)	95 (21)	120 (27)	160 (36)		–
	7.2		90 (20)	110 (24)	130 (29)	180 (40)	–		
	10		100 (22)	120 (27)	150 (33)	200 (45)	–		
	AR66	5	240 (54)	260 (58)	280 (63)	300 (67)	330 (74)	200 (45)	
		7.2	270 (60)	290 (65)	310 (69)	340 (76)	370 (83)		
		10	300 (67)	320 (72)	350 (78)	380 (85)	410 (92)		
		25	410 (92)	440 (99)	470 (105)	520 (117)	560 (126)		
		36	360 (81)	410 (92)	480 (108)	570 (128)	640 (144)		
		50	360 (81)	410 (92)	480 (108)	570 (128)	700 (157)		
	AR98	5	370 (83)	390 (87)	410 (92)	430 (96)	460 (103)	600 (135)	
		7.2	410 (92)	440 (99)	460 (103)	490 (110)	520 (117)		
		10	460 (103)	490 (110)	520 (117)	550 (123)	580 (130)		
		25	630 (141)	660 (148)	700 (157)	740 (166)	790 (177)		
		36	710 (159)	750 (168)	790 (177)	840 (189)	900 (200)		
		50	790 (177)	840 (189)	890 (200)	940 (210)	1000 (220)		
	Harmonic geared	AR24	All gear ratio	100 (22)	135 (30)	175 (39)	250 (56)	–	140 (31)
		AR46		180 (40)	220 (49)	270 (60)	360 (81)	510 (114)	220 (49)
AR66		320 (72)		370 (83)	440 (99)	550 (123)	720 (162)	450 (101)	
AR98		1090 (240)		1150 (250)	1230 (270)	1310 (290)	1410 (310)	1300 (290)	

■ **Permissible moment load of the Harmonic geared type**

If an eccentric load is applied on the flange surface when installing an arm or a table, do not exceed the permissible value shown in the table.

Model	Permissible moment load [N·m (oz-in)]
AR24	2.9 (410)
AR46	5.6 (790)
AR66	11.6 (1640)

Use the calculating formula below for the moment load.

- **Example 1; When an external force F is applied on the position of distance L from the center of the output flange**

L: Distance from the center of the output flange [m (in.)]

F: External force [N (oz)]

Moment load: $M [N·m (oz-in)] = F \times L$

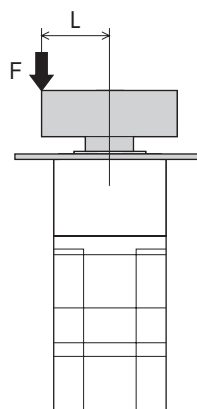

- **Example 2; When external forces F is applied on the position of distance L from the mounting face of the output flange**

L: Distance from the mounting face of the output flange [m (in.)]

F: External force [N (oz)]

Moment load: M [N·m (oz-in)] = $F \times (L + \text{coefficient "a"})$

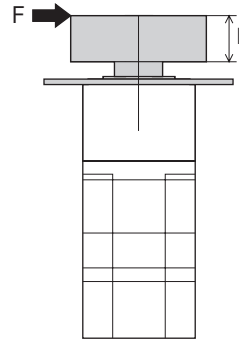

Model	coefficient "a"
AR24	0.00485
AR46	0.009
AR66	0.0114

3-5 Installing the driver

Mount the driver to a 35 mm (1.38 in.) width DIN rail. When two or more drivers are to be installed side by side, provide 10 mm (0.39 in.) and 25 mm (0.98 in.) clearances in the horizontal and vertical directions, respectively.



- Install the driver in an enclosure whose pollution degree is 2 or better environment, or whose degree of protection is IP54 minimum.
- Do not install any equipment that generates a large amount of heat or noise near the driver.
- Do not install the driver underneath the controller or other equipment vulnerable to heat.
- Check ventilation if the ambient temperature of the driver exceeds 50 °C (122 °F).
- Be sure to install the driver vertically (vertical position).

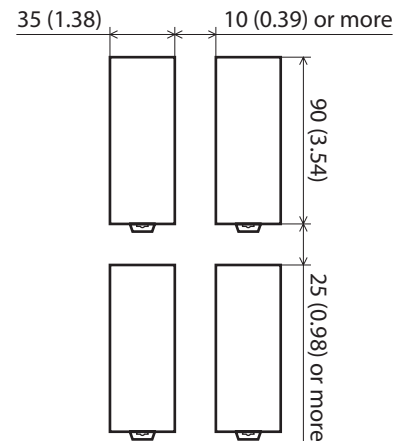

Unit: mm (in.)

1. Pull down the DIN lever of the driver and lock it. Hang the hook at the rear to the DIN rail.
2. Hold the driver to the DIN rail, and push up the DIN lever to secure.
3. Secure both sides of the driver using end plates.

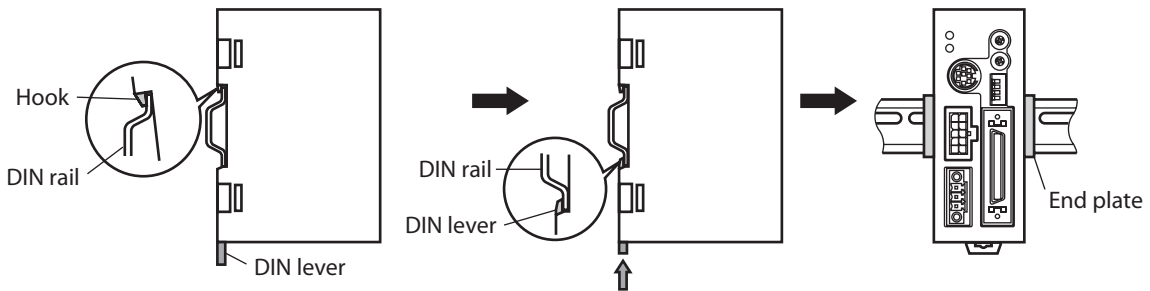

Removing from DIN rail

Pull the DIN lever down until it locks using a flat tip screwdriver, and lift the bottom of the driver to remove it from the rail. Use force of about 10 to 20 N (2.2 to 4.5 lb.) to pull the DIN lever to lock it. Excessive force may damage the DIN lever.

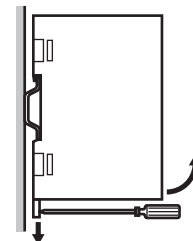

Dimension [unit: mm (in.)]

Mass: 0.17 kg (0.37 lb.)

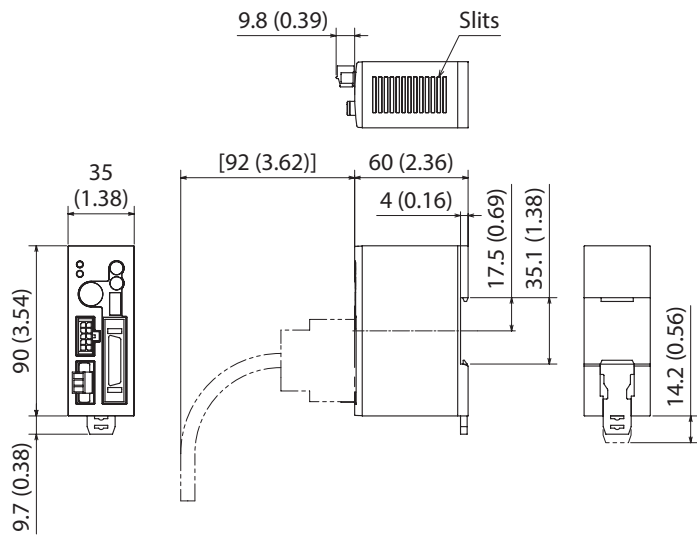

4 Connection

This chapter explains how to connect the motor, I/O signals and power supply to the driver, as well as grounding method. The installation and wiring methods in compliance with the EMC Directive as well as protection against noise are also explained.

⚠ WARNING For protection against electric shock, do not turn on the power supply until the wiring is completed.

4-1 Connection example

The following figure shows the electromagnetic brake type motor.

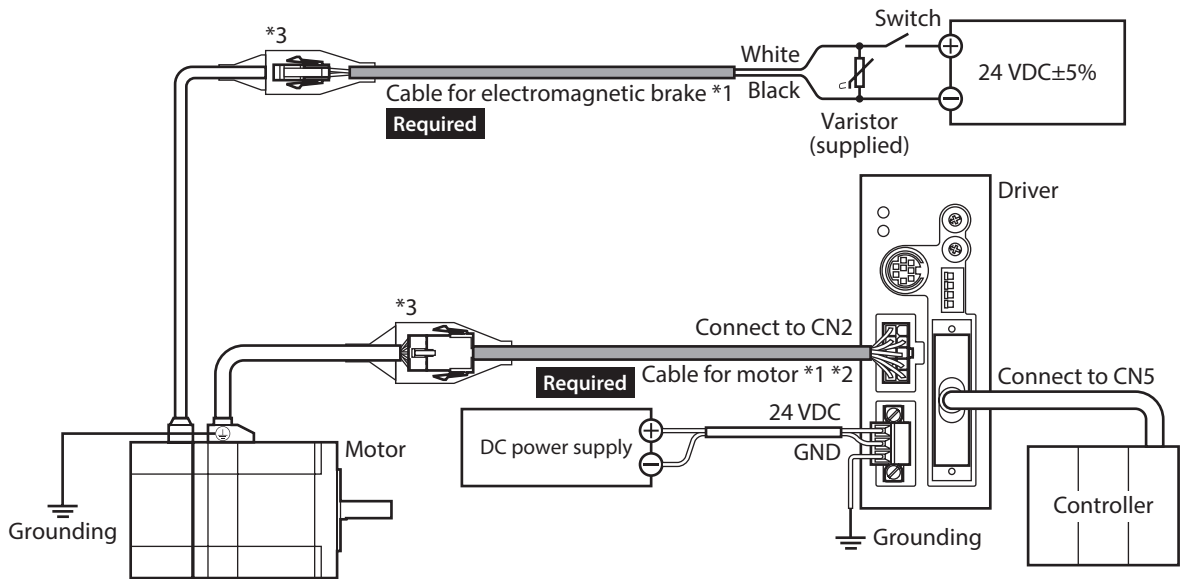

- *1 Cables represented in gray color are supplied with the product or sold separately.
- *2 Keep 30 m (98.4 ft.) or less for the wiring distance between the motor and driver.
- *3 If connector covers are attached on cables, cover the connected connectors using them.

Note

- Have the connector plugged in securely. Insecure connector connection may cause malfunction or damage to the motor or driver.
- When plugging/unplugging the connector, turn off the power and wait for the POWER LED to turn off before doing so. The residual voltage may cause electric shock.
- The lead wires of the "cable for electromagnetic brake" have polarities, so connect them in the correct polarities. If the lead wires are connected with their polarities reversed, the electromagnetic brake will not operate properly.

memo

- If the distance between the motor and driver is extended to 20 m (65.6 ft.) or longer, use a power supply of 24 VDC ± 4%.
- When unplugging the connector, do so while pressing the latches on the connector.
- When installing the motor to a moving part, use an accessory flexible cable offering excellent flexibility. Refer to p.91 for details.

● Cable size and tightening torque

Connector	Recommended cable size	Screw size	Tightening torque [N·m (oz·in)]
CN1	Stranded wire AWG24 to 16 (0.2 to 1.25 mm ²)	M2	0.22 to 0.25 (31 to 35)
CN5	Stranded wire AWG28 to 24 (0.08 to 0.2 mm ²)	–	–

● Current capacity of DC power supply for electromagnetic brake

Model	Current capacity
AR24, AR26	0.05 A or more
AR46	0.08 A or more
AR66, AR69, AR98	0.25 A or more

4-2 Connecting the I/O signals

Solder the I/O signal cable (AWG28 to 24: 0.08 to 0.2 mm²) to the CN5 connector (36 pins) while checking the pin numbers in the "Connector function table" provided below. Use a shielded cable for I/O signals. We provide an accessory driver cable allowing simple and easy connection with a driver, as well as connector-terminal block conversion unit. Refer to p.93 for details.

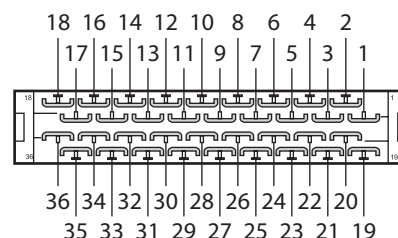

■ Connector function table

Pin No	Operating mode		Signal name	
	Positioning operation	Push-motion operation *	Positioning operation	Push-motion operation *
1	-		-	
2	GND		Ground connection	
3	ASG+		A-phase differential output (Line driver)	
4	ASG-			
5	BSG+		B-phase differential output (Line driver)	
6	BSG-			
7	TIM1+		Timing differential output (Line driver)	
8	TIM1-			
9	ALM+		Alarm output	
10	ALM-			
11	WNG+		Warning output	
12	WNG-			
13	END+		Positioning complete output	
14	END-			
15	READY+/ALO+ *		Operation ready complete output/Alarm code output 0 *	
16	READY-/ALO- *			
17	TLC+/AL1+ *		Torque limit output/Alarm code output 1 *	
18	TLC-/AL1- *			
19	TIM2+/AL2+ *		Timing output (open collector)/Alarm code output 2 *	
20	TIM2-/AL2- *			
21	GND		Ground connection	
22	IN-COM		Input common	
23	C-ON		Current on input	
24	CLR/ALM-RST		Deviation clear input/Alarm reset input	
25	CCM		Current control mode ON input	
26	CS	T-MODE *	Resolution selection input	Push-motion operation ON *
27	-	M0 *	-	Push-current setting selection input *
28	RETURN	M1 *	Return to electrical home operation	
29	P-RESET	M2 *	Position reset input	

Pin No	Operating mode		Signal name	
	Positioning operation	Push-motion operation *	Positioning operation	Push-motion operation *
30	FREE		Excitation OFF	
31	CW+/PLS+		CW pulse input/Pulse input (+5 V or line driver)	
32	CW-/PLS-			
33	CW+24V/PLS+24V		CW pulse input/Pulse input (+24 V)	
34	CCW+24V/DIR+24V		CCW pulse input/Direction input (+24 V)	
35	CCW+/DIR+		CCW pulse input/Direction input (+5 V or line driver)	
36	CCW-/DIR-			

* The signal will be enabled if the applicable setting was changed using the **MEXE02** or **OPX-2A**.

Note The factory setting of the C-ON input is normally open. Be sure to turn the C-ON input ON when operating the motor. Set the C-ON input to normally closed when the C-ON input is not used. Refer to p.96 for details.

■ Assembling the connector

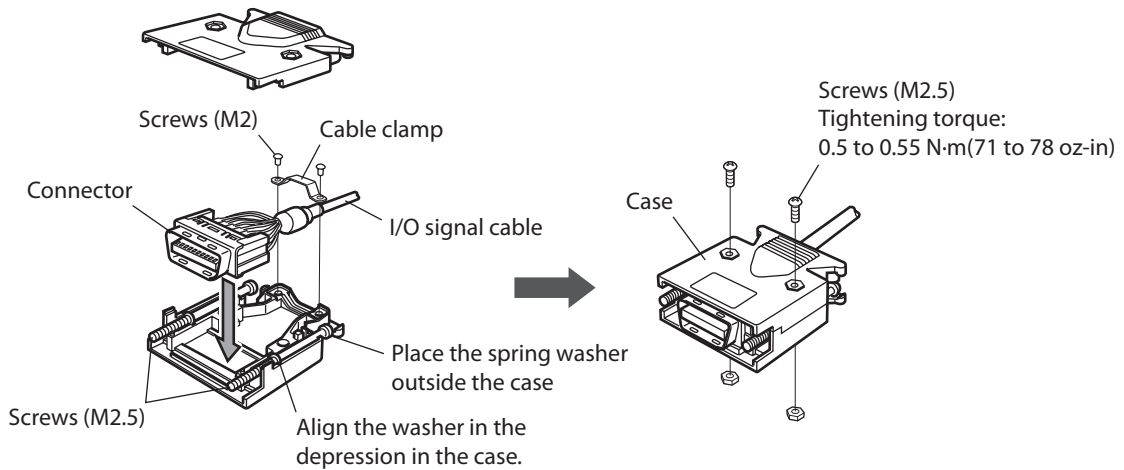

■ Connecting the connector

Insert the CN5 connector into the I/O signal connector (CN5) on the driver, and tighten the screw.
Tightening torque: 0.3 to 0.35 N·m (42 to 49 oz-in)

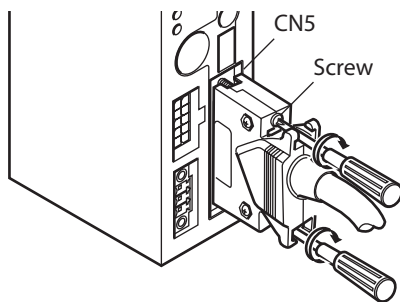

Note Be certain the I/O signal cable is as short as possible. The maximum input frequency will decrease as the cable length increases.

■ Connecting to a current sink output circuit

- When pulse input is of line driver type

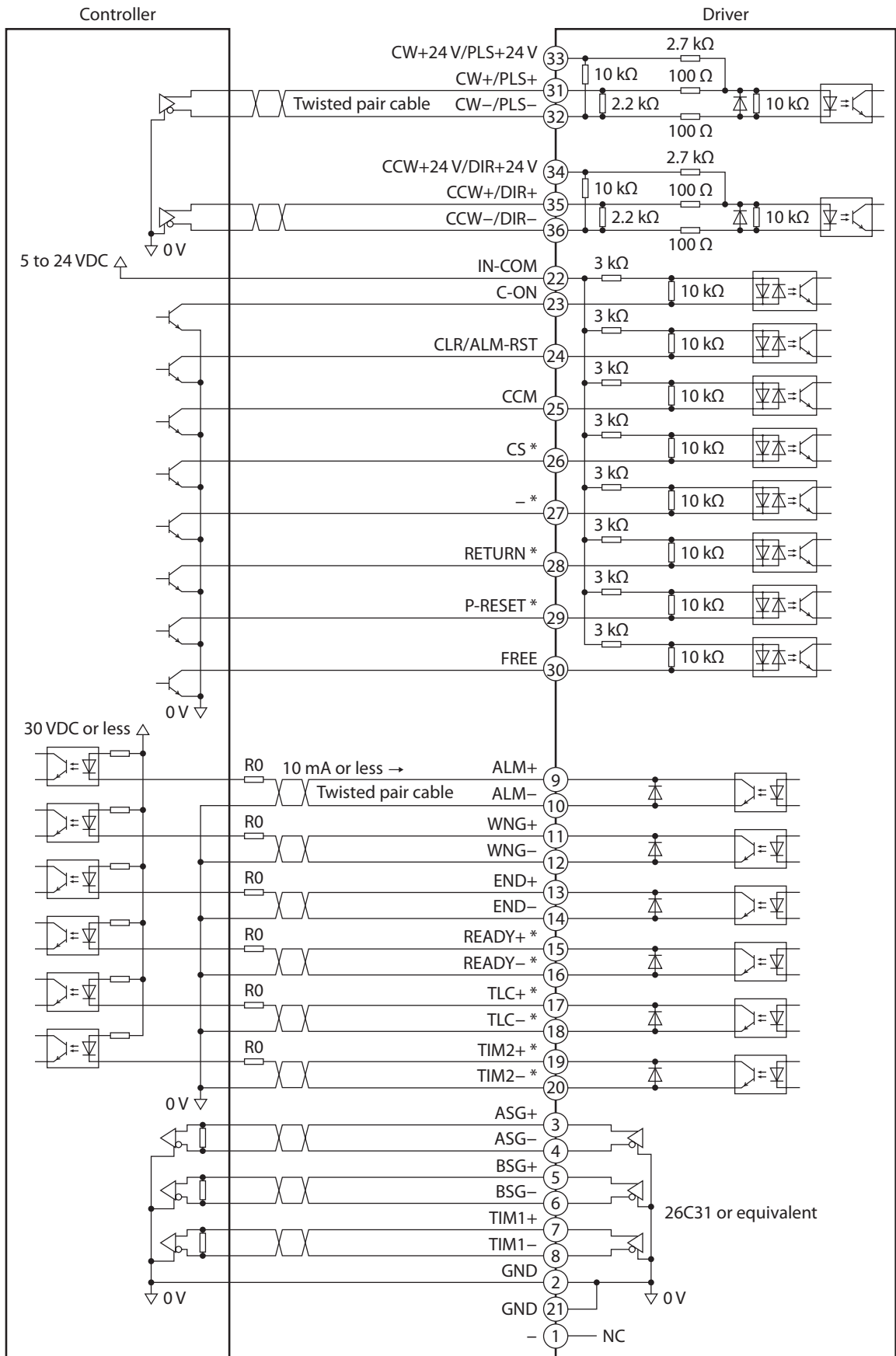

3 DC power input type

* Initial value

- memo**
- Use output signals at 30 VDC or less. If the current exceeds 10 mA, connect an external resistor R0.
 - The ASG output, BSG output and TIM1 output are line driver outputs. When connecting a line driver output, receive the output signal using a line receiver. Also, be sure to connect pins 2 or 21 of the driver to the GND on the line receiver, and connect a termination resistor of 100 Ω or more between the driver and the input of the line receiver.

● When pulse input is of open collector type (input voltage 5 VDC)

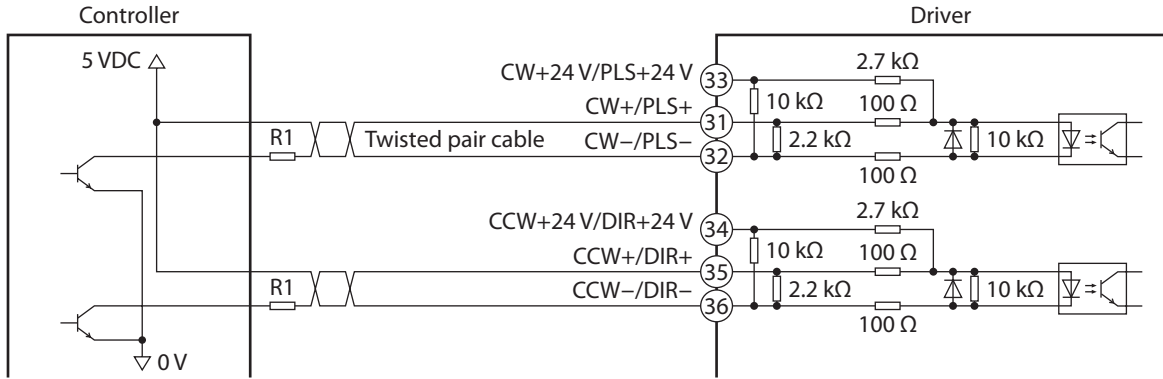

- memo** When the 12 VDC is used, be sure to connect an external resistor R1 (1 kΩ, 0.25 W or more) so that the current exceeding 20 mA does not flow.

● When pulse input is of open collector type (input voltage 24 VDC)

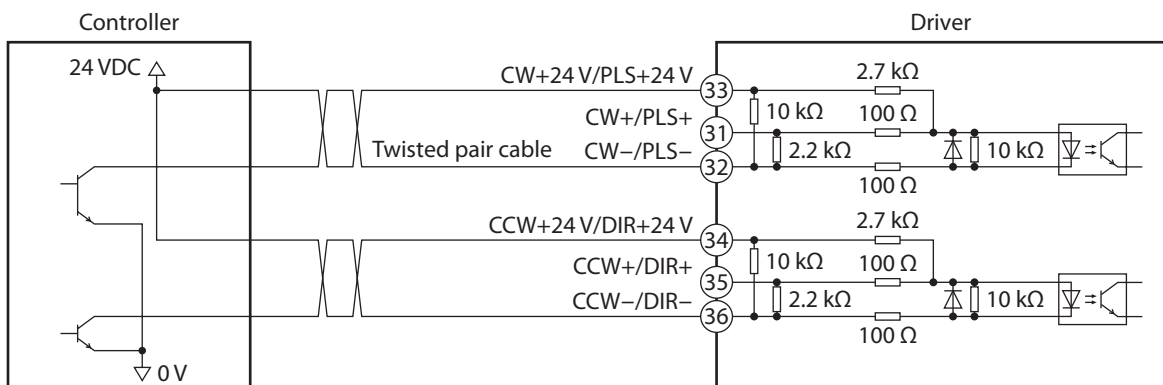

■ Connecting to a current source output circuit

- When pulse input is of line driver type

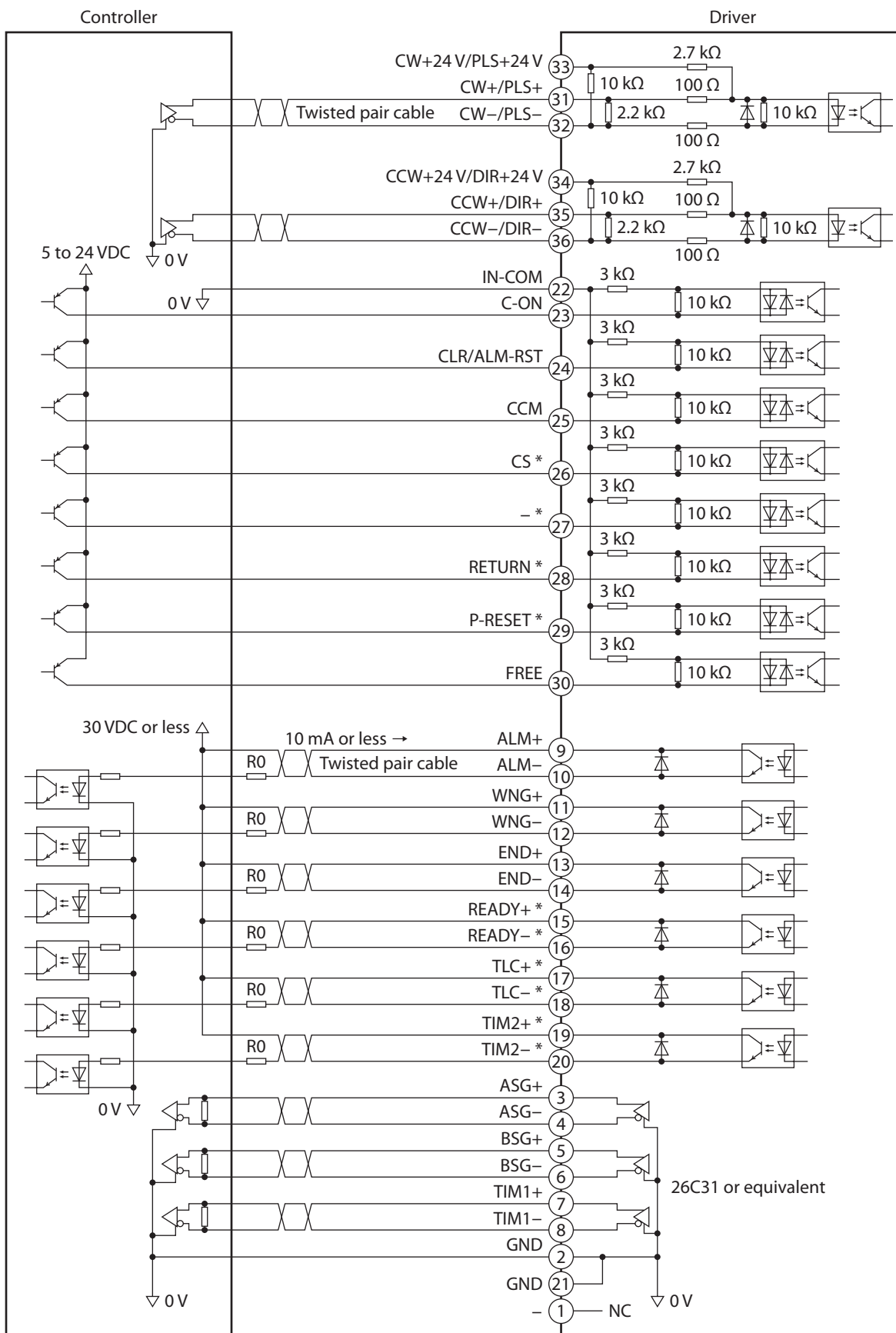

3 DC power input type

* Initial value

- memo**
- Use output signals at 30 VDC or less. If the current exceeds 10 mA, connect an external resistor R0.
 - The ASG output, BSG output and TIM1 output are line driver outputs. When connecting a line driver output, receive the output signal using a line receiver. Also, be sure to connect pins 2 or 21 of the driver to the GND on the line receiver, and connect a termination resistor of 100 Ω or more between the driver and the input of the line receiver.

● When pulse input is of open collector type (input voltage 5 VDC)

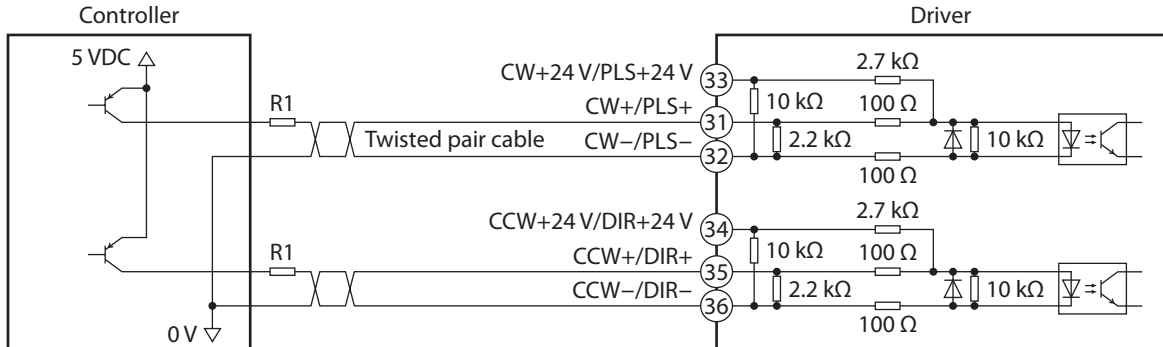

- memo** When the 12 VDC is used, be sure to connect an external resistor R1 (1 kΩ, 0.25 W or more) so that the current exceeding 20 mA does not flow.

● When pulse input is of open collector type (input voltage 24 VDC)

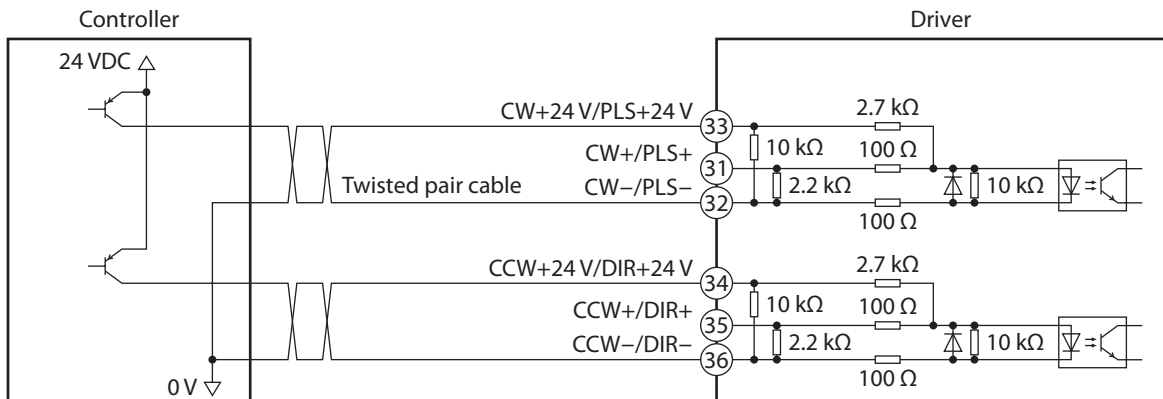

■ Timing chart

When turning the main power supply on and turning the C-ON input ON, the motor will be excited.
The READY output will turn ON and pulse input will be enabled.

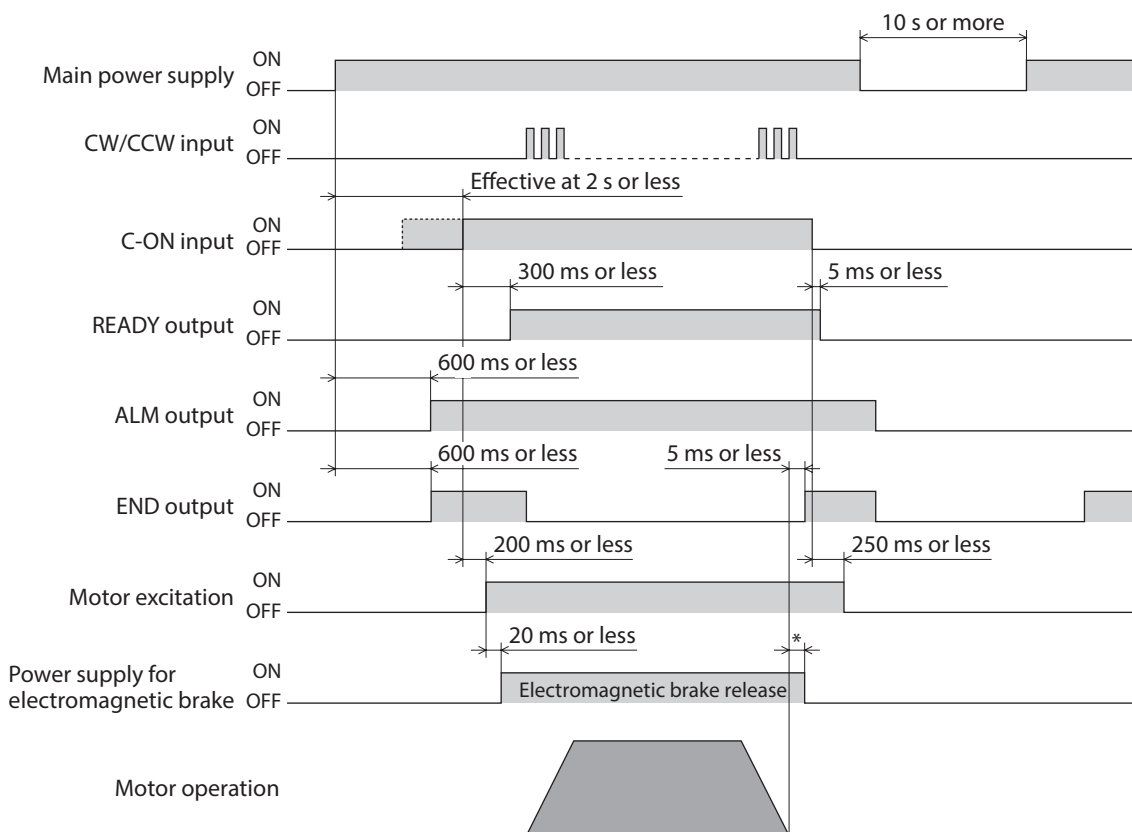

* **AR24, AR26:** 50 ms or less
AR46, AR66, AR69, AR98: 30 ms or less

memo The electromagnetic brake is required to control by switching the ON/OFF status of the power supply for electromagnetic brake. Perform the control of the electromagnetic brake by yourself because it is not performed by the driver.

4-3 Connecting the power supply and grounding the driver

■ Connecting the power supply

Use the CN1 connector (3 pins) to connect the power supply cable (AWG24 to 16: 0.2 to 1.25 mm²) to the main power supply input connector (CN1) on the driver.
Use a power supply that can supply the current capacity show in the table.

Model	Power supply input voltage	Power supply current capacity
AR14	24 VDC±10%	0.4 A or more
AR15		0.5 A or more
AR24, AR26		0.9 A or more
AR46	24 VDC±10% 48 VDC±5%	1.4 A or more
AR66		3.1 A or more
AR69		3.0 A or more
AR98		2.5 A or more

- Note**
- Pay attention to the polarity of the power supply. Reverse-polarity connection may cause damage to the driver.
 - Do not wire the power supply cable of the driver in the same cable duct with other power line or motor cable. Doing so may cause malfunction due to noise.
 - When cycle the power or plugging/unplugging the connector, turn off the power and wait for the POWER LED to turn off.

■ Connecting method

1. Strip the insulation cover of the lead wire by 7 mm (0.28 in.)
2. Insert each lead wire into the CN1 connector and tighten the screw with a screwdriver
Connector screw size: M2
Tightening torque: 0.22 to 0.25 N·m (31 to 35 oz-in)
3. Insert the CN1 connector into the CN1 and tighten the screw.
Connector screw size: M2.5
Tightening torque: 0.4 N·m (56 oz-in)

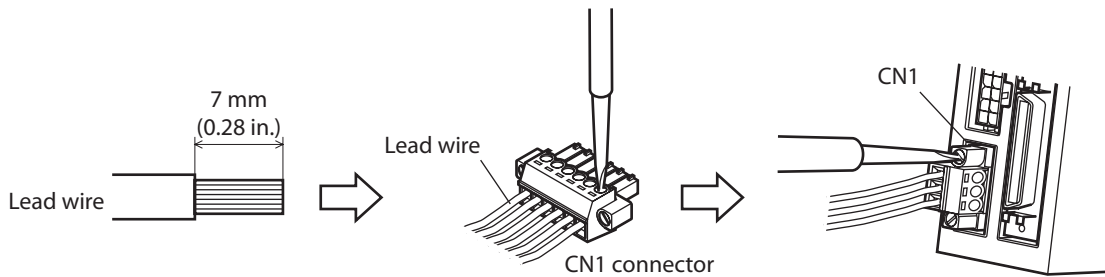

■ Grounding the driver

Ground the frame ground terminal (CN1) of driver as necessary.
Ground using a wire of AWG24 to 16 (0.2 to 1.25 mm²), and do not share the protective earth terminal with a welder or any other power equipment.

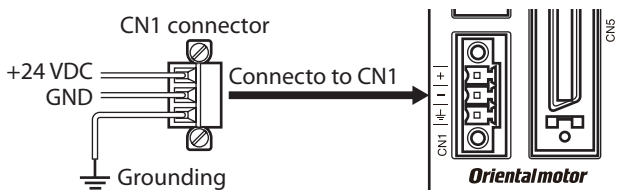

4-4 Grounding the motor

Be sure to ground the Protective Earth Terminal of the motor.

- Screw size: M4
- Tightening torque: 1.2 N·m (170 oz-in)

Use a grounding wire of AWG18 (0.75 mm²) or more.

Use a round terminal in combination with an inner-clip washer and bolt it in place to secure the grounding connection. Ground wires and crimp terminals are not supplied.

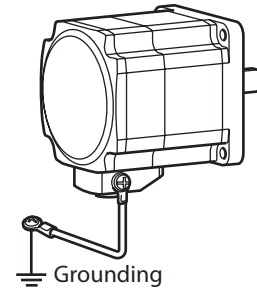

4-5 Connecting the data setter

Connect the communication cable for the support software or **OPX-2A** cable to the data edit connector (CN4) on the driver.

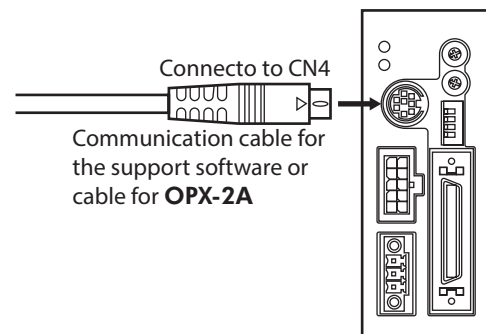

⚠ CAUTION

The main power supply connector (CN1), data edit connector (CN4) and I/O signal connector (CN5) of the driver are not electrically insulated. When grounding the positive terminal of the power supply, do not connect any equipment (PC, etc.) whose negative terminal is grounded. Doing so may cause the driver and these equipment to short, damaging both.

4-6 Noise measures

The electrical noise is of two types: One is a noise to invade into the driver from the outside and cause the driver malfunction, and the other is a noise to emit from the driver and cause peripheral equipments malfunction.

For the noise that is invaded from the outside, take measures to prevent the driver malfunction. It is needed to take adequate measures because signal lines are very likely to be affected by the noise.

For the noise that is emitted from the driver, take measures to suppress it.

■ Measures against electrical noise

There are the following three methods mainly to take measures against the electrical noise.

● Noise suppression

- When relays or electromagnetic switches are used together with the system, use noise filters and CR circuits to suppress surges generated by them.
- Use an accessory cable when extending a wiring distance between the motor and driver.
- Cover the driver by a metal plate such as aluminum. This is effective in shielding the electrical noise emitted from the driver.

● Prevention of noise propagation

- Connect a noise filter in the power supply cable of driver.
- Place the power lines, such as the motor and power supply cables, keeping a distance of 200 mm (7.87 in.) or more from the signal lines, and also do not bundle them or wire them in parallel. If the power cables and signal cables have to cross, cross them at a right angle.
- Use shielded twisted pair cables for power lines and signal lines.
- Keep cables as short as possible without coiling and bundling extra lengths.

- When grounding PE terminals of multiple drivers to a grounding point, it becomes more effective to block the electrical noise since impedance on the grounding point is decreased. However, ground them so that a potential difference does not occur among the grounding points. An accessory driver cable including with a ground wire is available. Refer to p.93 for details.
- To ground a shielded cable, use a metal cable clamp that will maintain contact with the entire circumference of the cable. Ground the cable clamp near the product.

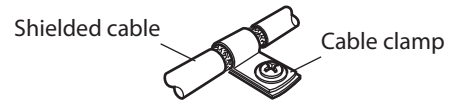

● **Suppression of effect by noise propagation**

- Loop the noise propagated cable around a ferrite core. Doing so will prevent the propagated noise invades into the driver or emits from the driver. The frequency band in which an effect by the ferrite core can be seen is generally 1 MHz or more. Check the frequency characteristics of the ferrite core used. To increase the effect of noise attenuation by the ferrite core, loop the cable a lot.
- Change the transmission method of the pulse signal to the line driver type in order to prevent noise effects. When the pulse signal of the controller is the open collector type, use an accessory pulse signal converter for noise immunity. Refer to p.94 for details.

■ **Noise suppression parts**

● **Noise filter**

- Connect the following noise filter (or equivalent) to the DC power line. Doing so will prevent the propagated noise through the power line. Install the noise filter as close to the input terminals of DC power supply as possible.

Manufacture	Model
SOSHIN ELECTRIC CO.,LTD	HF2010A-UPF
Schaffner EMC	FN2070-10-06

- When using a power supply transformer, be sure to connect a noise filter to the AC input side of the power supply transformer.
- Use the AWG18 (0.75 mm²) or thicker wire for the input and output cables of the noise filter, and secure firmly using a cable clamp etc. so that the cable does not come off the enclosure.
- Place the input cable as far apart as possible from the output cable, and do not wire the cables in parallel. If the input and output cable are placed at a close distance or if they are wired in parallel, the noise in the enclosure affects the power cable through stray capacitance, and the noise suppressing effect will reduce.
- Connect the ground terminal of the noise filter to the grounding point, using as thick and short a wire as possible.
- When connecting a noise filter in an enclosure, wire the input cable of the noise filter as short as possible. Wiring in long distance may reduce the noise suppressing effect.

■ **Noise suppression parts (accessories)**

Refer to p.93 for accessories.

● **Driver cable**

This cable is a shielded twisted pair cable for good noise immunity to connect the driver and controller. The ground wires useful to grounding are provided at both ends of the cable. The EMC measures are conducted using the Oriental Motor driver cable.

● **Connector-terminal block conversion unit**

This is an accessory in which I/O signals of a controller can be connected on the terminal block. The ground wires useful to grounding are provided at both ends of the cable.

● **Pulse signal converter for noise immunity**

This is a noise filter for pulse signal lines. It eliminates the noise of the pulse signal and changes the pulse signal to the line driver type.

● **Surge suppressor**

This product is effective to suppress the surge which occurs in a relay contact part. Connect it when using a relay or electromagnetic switch. CR circuit for surge suppression and CR circuit module are provided.

4-7 Conformity to the EMC Directive

Effective measures must be taken against the EMI that the motor and driver may give to adjacent control-system equipment, as well as the EMS of the motor and driver itself, in order to prevent a serious functional impediment in the machinery. The use of the following installation and wiring methods will enable the motor and driver to be compliant with the EMC Directive. Refer to p.166 for the applicable standards.

Oriental Motor conducts EMC measurements on its motors and drivers in accordance with "Example of motor and driver installation and wiring" below.

The user is responsible for ensuring the machine's compliance with the EMC Directive, based on the installation and wiring explained below.

- **Connecting noise filter**

In large electrically noisy environments, connect a noise filter.

- **Connecting the power supply**

Use a DC power supply that conforms to the EMC Directive.

Use a shielded twisted pair cable for wiring. Refer to "Prevention of noise propagation" on p.83 for wiring method.

- **Connecting the motor cable**

Use an accessory motor cable when extending the wiring distance between the motor and driver.

- **Connecting the signal cable**

Refer to "Prevention of noise propagation" on p.83.

- **How to ground**

- The cable used to ground the motor, driver and noise filter must be as thick and short as possible so that no potential difference is generated.
- Choose a large, thick and uniformly conductive surface for the grounding point.
- Be sure to ground the Protective Earth Terminal of the motor and driver. Refer to p.82, p.83 for grounding method.

- **Example of motor and driver installation and wiring**

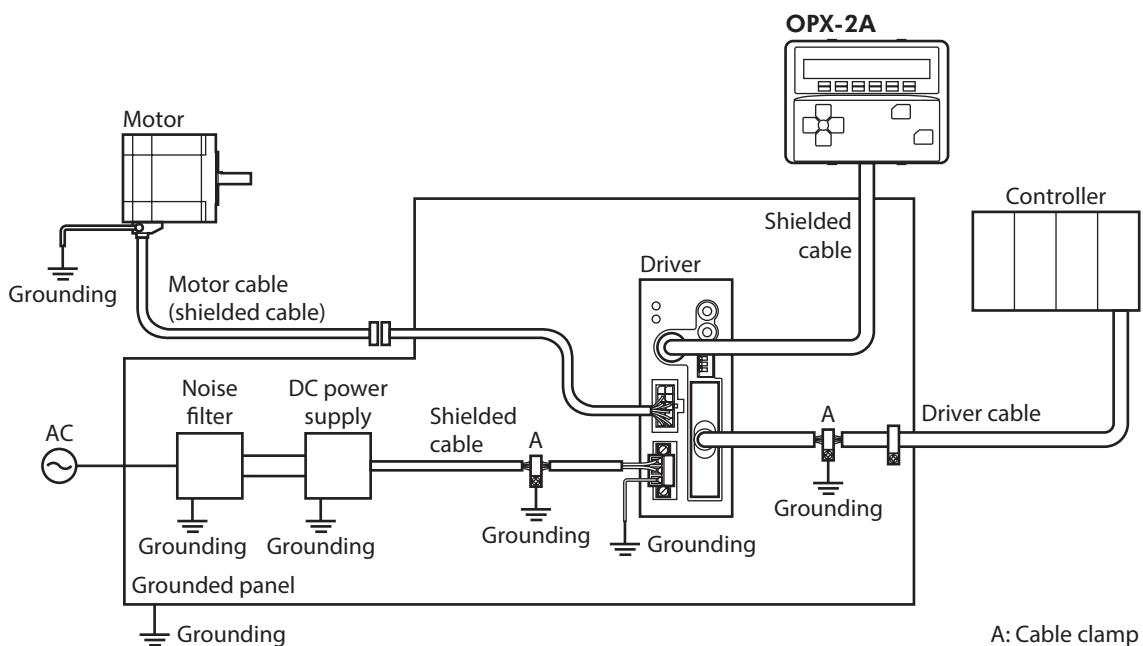

Note The driver uses parts that are sensitive to electrostatic charge. Take measures against static electricity since static electricity may cause the driver to malfunction or suffer damage.

5 Guidance

If you are new to the **AR** Series driver, read this chapter and you will be able to perform basic motor operations quickly.

Note Before operating the motor, check the condition of the surrounding area to ensure safety.

STEP 1 Check the connection

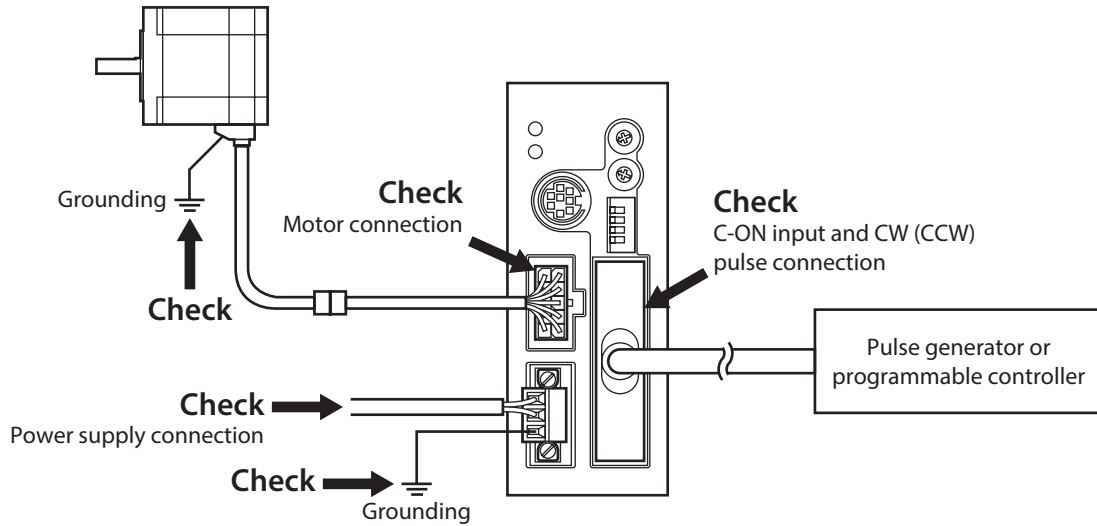

STEP 2 Set the switches

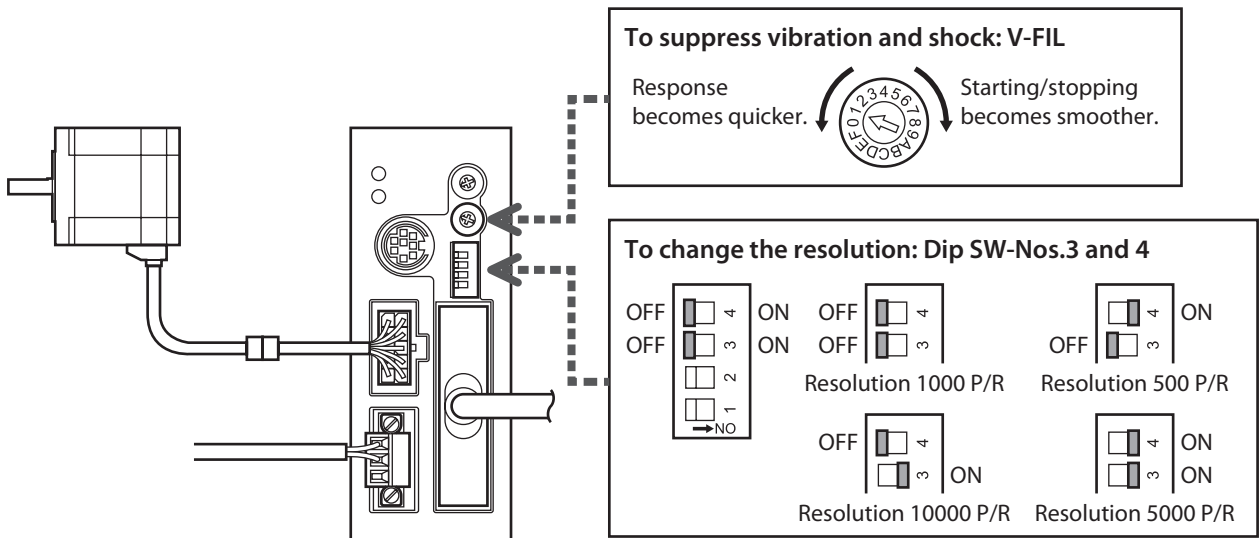

STEP 3 Turn on the power supply and check the LED

Check that the LED condition has become as shown in the figures.

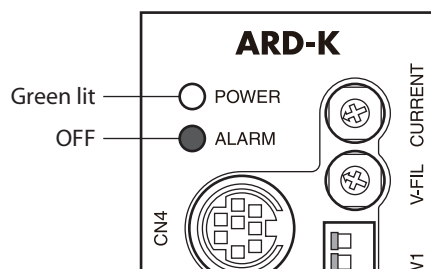

- When the ALARM LED (red) is blinking:
Count the number of times the LED blinks, and check the alarm information. (⇒ p.143)

STEP 4 Operate the motor

3. Check the motor rotates according to the setting.

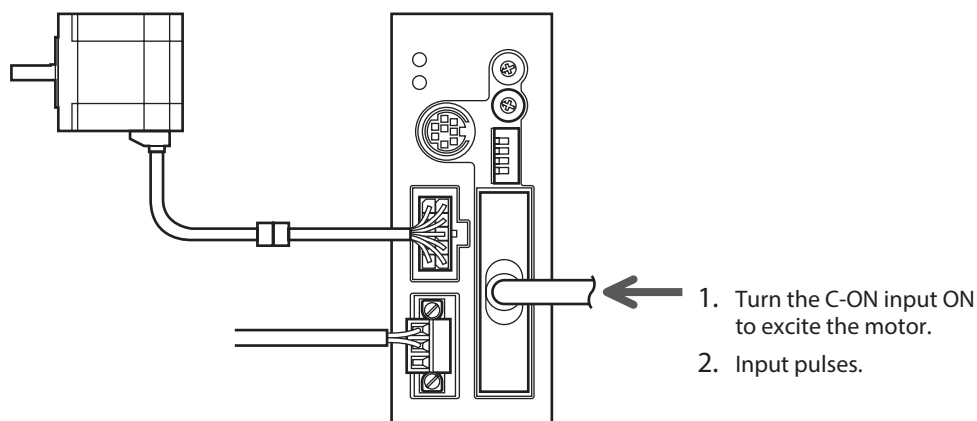

STEP 5 Were you able to operate the motor properly?

How did it go? Were you able to operate the motor properly? If the motor does not function, check the following points:

- Is the C-ON input ON?
- Is any alarm present?
- Are the power supply and motor connected securely?

For more detailed settings and functions, refer to "4 AC power input type/DC power input type Common" on p.95.

6 Setting

This chapter explains how to change and set the driver functions using the switches on the front face of the driver.

Note Before operating any switch, turn off the driver power and wait for the POWER LED to turn off.

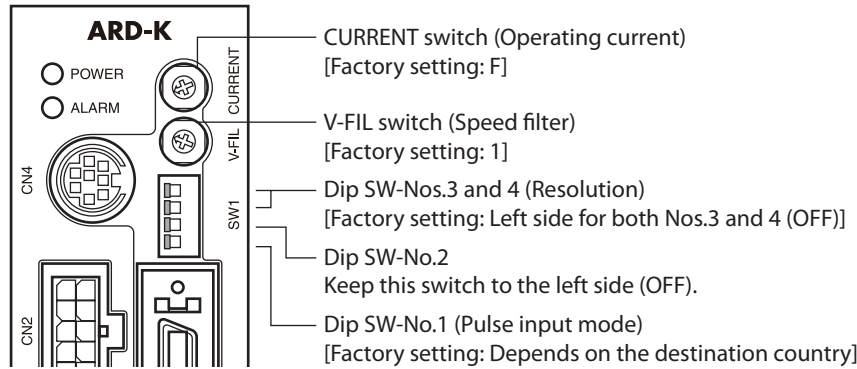

6-1 Resolution

Set a resolution when using in combination with a mechanism product such as a geared motor or an actuator. Use the Dip SW-Nos.3 and 4 to set a desired resolution per revolution of the motor output shaft.

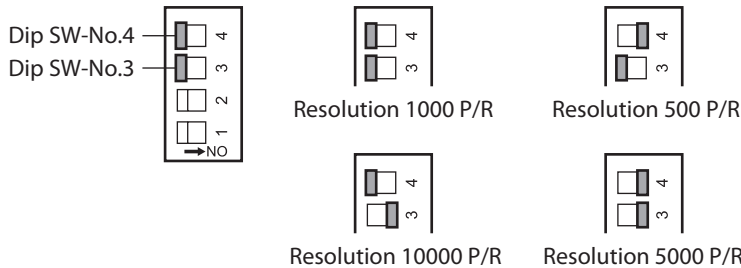

- memo**
- The new setting of the Dip SW will be enabled after the power is cycled.
 - When the resolution is changed with the CS input, set the Dip SW-No.3 to the left side (OFF). If the Dip SW-No.3 is set to the right side (ON), the resolution will not change even when the CS input is turned ON.

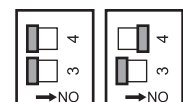

- To change the basic setting for resolution: Refer to p.107.

6-2 Pulse input mode

Set a desired pulse input mode of the driver according to the pulse output mode of the controller (pulse generator) used with the driver. Set a desired mode using the Dip SW-No.1.

- Dip SW-No.1 is set to the right side (ON): 1-pulse input mode (when the PLS input and DIR input are used)
- Dip SW-No.1 is set to the left side (OFF): 2-pulse input mode (when the CW input and CCW input are used)

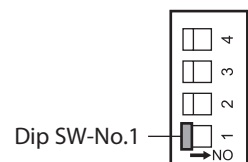

memo The new setting of the Dip SW will be enabled after the power is cycled.

- To change the basic setting for pulse input mode: Refer to p.109.

6-3 Operating current

Set a desired operating current using the CURRENT switch. The operating current to be set is the maximum output current multiplied by the operating current rate (%) set to each dial setting of the current setting switch, where "F" corresponds to 100%. One of 16 operating current levels from 0 to F can be set. If the load is small and there is an ample allowance for torque, motor temperature rise can be suppressed by setting a lower operating current. The dial settings and corresponding operating current rates are listed below.

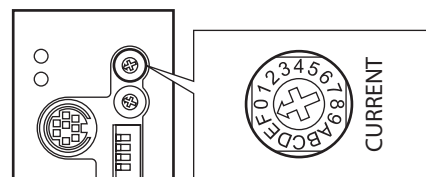

Dial setting	Operating current rate (%)	Dial setting	Operating current rate (%)
0	6.3	8	56.3
1	12.5	9	62.5
2	18.8	A	68.8
3	25.0	B	75.0
4	31.3	C	81.3
5	37.5	D	87.5
6	43.8	E	93.8
7	50.0	F	100 (factory setting)

Note Excessively low operating current may cause a problem in starting the motor or holding the load in position. Do not lower the operating current more than necessary.

- To change the basic setting for operating current: Refer to p.122.

6-4 Speed filter

The motor response to input pulses can be adjusted with the V-FIL switch. One of 16 speed filter levels from 0 to F can be set. When setting a higher value for the speed filter, lower vibration at low speed operation or smoother operation at starting/stopping of the motor can be achieved. However, if this setting is too high, synchronization performance is decreased. Set a suitable value based on the load or application.

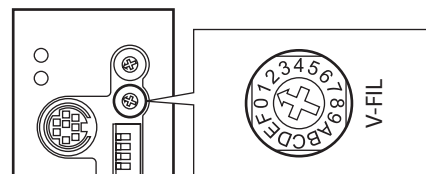

Dial setting	Speed filter time constant (ms)	Dial setting	Speed filter time constant (ms)
0	0	8	30
1	1 (factory setting)	9	50
2	2	A	70
3	3	B	100
4	5	C	120
5	7	D	150
6	10	E	170
7	20	F	200

- When the V-FIL switch is set to 0 (minimum)

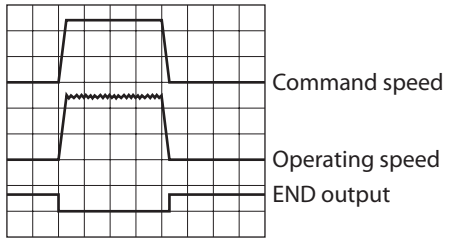

- When the V-FIL switch is set to F (maximum)

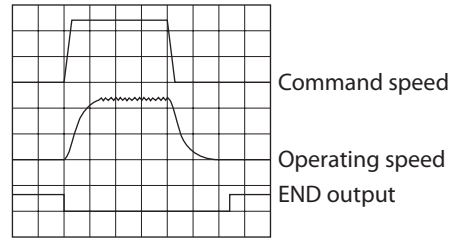

- To change the basic setting for speed filter: Refer to p.123.

7 Accessories

7-1 Motor cable set

■ Connection cable set

Use when connecting a motor and a driver.
 The cable set for electromagnetic brake motors consists of two cables, one for motor and the other for electromagnetic brake.

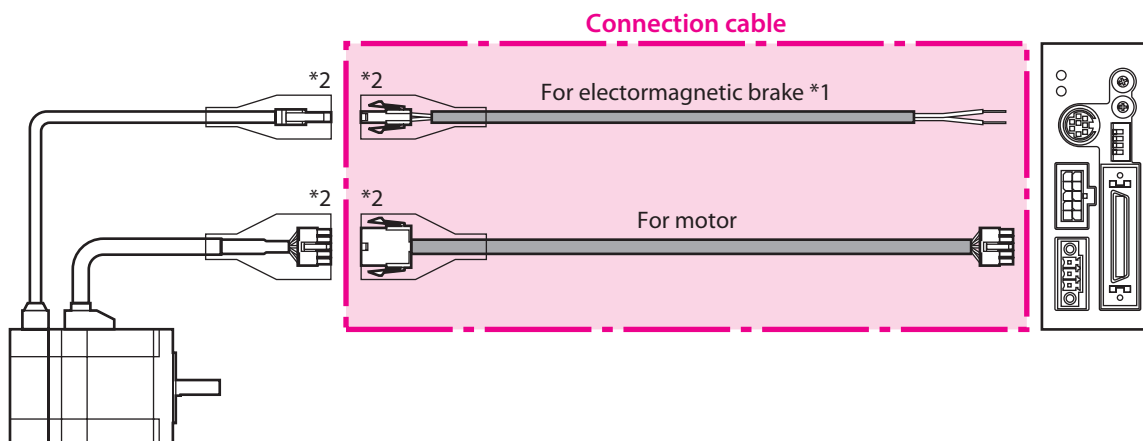

*1 Only when the motor is of electromagnetic brake type.
 *2 A connector cover may be attached depending on the specification.

memo When installing the motor on a moving part, use a flexible cable having excellent flex resistance.

3 DC power input type

● Connection cable set For standard type motor

Model (With connector cover)	Model (Without connector cover)	Length [m (ft.)]
CC010VAF2	CC010VA2F2	1 (3.3)
CC020VAF2	CC020VA2F2	2 (6.6)
CC030VAF2	CC030VA2F2	3 (9.8)
CC050VAF2	CC050VA2F2	5 (16.4)
CC070VAF2	CC070VA2F2	7 (23)
CC100VAF2	CC100VA2F2	10 (32.8)
CC150VAF2	CC150VA2F2	15 (49.2)
CC200VAF2	CC200VA2F2	20 (65.6)
CC300VAF2	CC300VA2F2	30 (98.4)

● Connection cable set For electromagnetic brake type motor

Model (With connector cover)	Model (Without connector cover)	Length [m (ft.)]
CC010VAFB2	CC010VA2FB2	1 (3.3)
CC020VAFB2	CC020VA2FB2	2 (6.6)
CC030VAFB2	CC030VA2FB2	3 (9.8)
CC050VAFB2	CC050VA2FB2	5 (16.4)
CC070VAFB2	CC070VA2FB2	7 (23)
CC100VAFB2	CC100VA2FB2	10 (32.8)
CC150VAFB2	CC150VA2FB2	15 (49.2)
CC200VAFB2	CC200VA2FB2	20 (65.6)
CC300VAFB2	CC300VA2FB2	30 (98.4)

● Flexible connection cable set
For standard type motor

Model (With connector cover)	Model (Without connector cover)	Length [m (ft.)]
CC010VAR2	CC010VA2R2	1 (3.3)
CC020VAR2	CC020VA2R2	2 (6.6)
CC030VAR2	CC030VA2R2	3 (9.8)
CC050VAR2	CC050VA2R2	5 (16.4)
CC070VAR2	CC070VA2R2	7 (23)
CC100VAR2	CC100VA2R2	10 (32.8)
CC150VAR2	CC150VA2R2	15 (49.2)
CC200VAR2	CC200VA2R2	20 (65.6)
CC300VAR2	CC300VA2R2	30 (98.4)

● Flexible connection cable set
For electromagnetic brake type motor

Model (With connector cover)	Model (Without connector cover)	Length [m (ft.)]
CC010VARB2	CC010VA2RB2	1 (3.3)
CC020VARB2	CC020VA2RB2	2 (6.6)
CC030VARB2	CC030VA2RB2	3 (9.8)
CC050VARB2	CC050VA2RB2	5 (16.4)
CC070VARB2	CC070VA2RB2	7 (23)
CC100VARB2	CC100VA2RB2	10 (32.8)
CC150VARB2	CC150VA2RB2	15 (49.2)
CC200VARB2	CC200VA2RB2	20 (65.6)
CC300VARB2	CC300VA2RB2	30 (98.4)

■ Extension cable set

Use when extending the distance between a motor and a driver or when the length of the connection cable used is not enough. Extend the distance by connecting the extension cable to the connection cable.

The cable set for electromagnetic brake motors consists of two cables, one for motor and the other for electromagnetic brake.

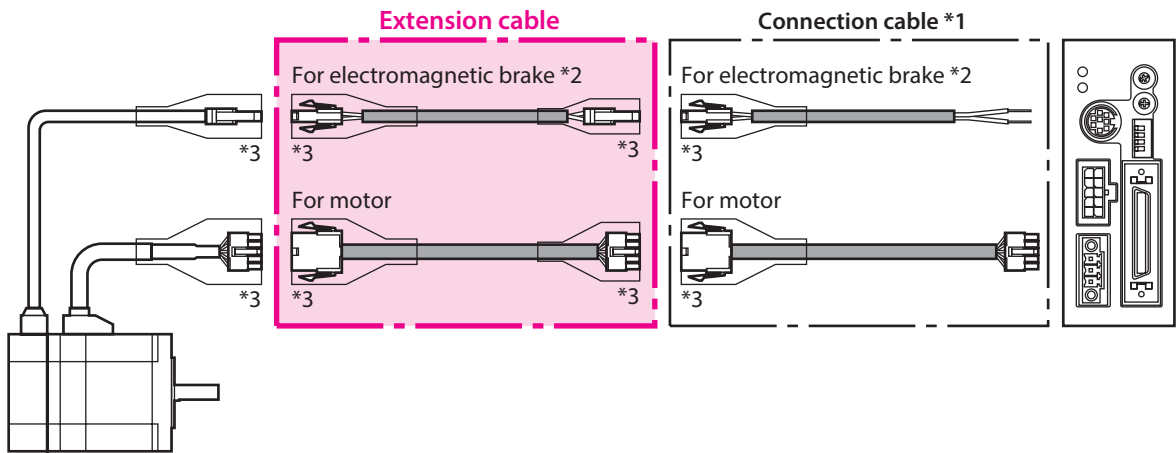

*1 Use the connection cable used.

*2 Only when the motor is of electromagnetic brake type.

*3 A connector cover may be attached depending on the specification.



- When installing the motor on a moving part, use a flexible cable having excellent flex resistance.
- When extending the wiring length by connecting an extension cable to the connection cable, keep the total cable length to 30 m (98.4 ft.) or less.

● Extension cable set
For standard type motor

Model (With connector cover)	Model (Without connector cover)	Length [m (ft.)]
CC010VAFT2	CC010VA2F2	1 (3.3)
CC020VAFT2	CC020VA2F2	2 (6.6)
CC030VAFT2	CC030VA2F2	3 (9.8)
CC050VAFT2	CC050VA2F2	5 (16.4)
CC070VAFT2	CC070VA2F2	7 (23)
CC100VAFT2	CC100VA2F2	10 (32.8)
CC150VAFT2	CC150VA2F2	15 (49.2)
CC200VAFT2	CC200VA2F2	20 (65.6)

● Extension cable set
For electromagnetic brake type motor

Model (With connector cover)	Model (Without connector cover)	Length [m (ft.)]
CC010VAFB2	CC010VA2FB2	1 (3.3)
CC020VAFB2	CC020VA2FB2	2 (6.6)
CC030VAFB2	CC030VA2FB2	3 (9.8)
CC050VAFB2	CC050VA2FB2	5 (16.4)
CC070VAFB2	CC070VA2FB2	7 (23)
CC100VAFB2	CC100VA2FB2	10 (32.8)
CC150VAFB2	CC150VA2FB2	15 (49.2)
CC200VAFB2	CC200VA2FB2	20 (65.6)

- **Flexible extension cable set**
For standard type motor

Model (With connector cover)	Model (Without connector cover)	Length [m (ft.)]
CC010VART2	CC010VA2R2	1 (3.3)
CC020VART2	CC020VA2R2	2 (6.6)
CC030VART2	CC030VA2R2	3 (9.8)
CC050VART2	CC050VA2R2	5 (16.4)
CC070VART2	CC070VA2R2	7 (23)
CC100VART2	CC100VA2R2	10 (32.8)
CC150VART2	CC150VA2R2	15 (49.2)
CC200VART2	CC200VA2R2	20 (65.6)

- **Flexible extension cable set**
For electromagnetic brake type motor

Model (With connector cover)	Model (Without connector cover)	Length [m (ft.)]
CC010VARBT2	CC010VA2RBT2	1 (3.3)
CC020VARBT2	CC020VA2RBT2	2 (6.6)
CC030VARBT2	CC030VA2RBT2	3 (9.8)
CC050VARBT2	CC050VA2RBT2	5 (16.4)
CC070VARBT2	CC070VA2RBT2	7 (23)
CC100VARBT2	CC100VA2RBT2	10 (32.8)
CC150VARBT2	CC150VA2RBT2	15 (49.2)
CC200VARBT2	CC200VA2RBT2	20 (65.6)

7-2 Setting tool

■ Communication cable for the support software

Be sure to purchase the communication cable for the support software when connecting a driver and PC in which the support software **MEXE02** has been installed.

This is a set of a PC interface cable and USB cable. The cable is connected to the USB port on the PC.

Model: **CC05IF-USB** [5 m (16.4 ft.)]

The **MEXE02** can be downloaded from Oriental Motor Website Download Page. Also, the **MEXE02** is provided in the form of a storage medium. For details, check out our web site or contact your nearest Oriental Motor sales office.

■ Data setter

The data setter lets you set parameters for your **AR** Series with ease and also functions as a monitor.

Model: **OPX-2A**

7-3 Wiring support tool

■ Driver cable

A shielded cable for driver I/O signals (36 pins) offering excellent noise resistance.

The ground wires useful to grounding are provided at both ends of the cable.

Model	Connector type	Length [m (ft.)]
CC36D1E	Straight	1 (3.3)
CC36D2E		2 (6.6)
CC36D1AE	Right Angle	1 (3.3)
CC36D2AE		2 (6.6)

■ Connector-terminal block conversion unit

The driver and programmable controller can be connected on the terminal block.

A shielded cable is used. The ground wires useful to grounding are provided at both ends of the cable.

Model	Connector type	Length [m (ft.)]
CC36T10E	Single-row	1 (3.3)
CC36WT05AE	2 rows	0.5 (1.6)
CC36WT10AE		1 (3.3)

■ **Pulse signal converter for noise immunity**

It eliminates the noise of the pulse signal and changes the pulse signal to the line driver type.

Model: **VCS06**

■ **CR circuit for surge suppression**

This product is effective to suppress the surge which occurs in a relay contact part. Use it to protect the contacts of the relay or switch.

Model: **EPCR1201-2**

■ **CR circuit module**

This product is effective to suppress the surge which occurs in a relay contact part. Use this product to protect the contacts of the relay or switch.

4 pieces of CR circuit for surge suppression are mounted on the compact circuit, and this product can be installed to the DIN rail. This product can make the wiring easily and securely since it also supports terminal block connection.

Model: **VCS02**

4 AC power input type/ DC power input type Common

This part explains common contents to the AR Series AC power input type and DC power input type.

◆Table of contents

1	Explanation of I/O signals	96		
1-1	Input signals	96		
1-2	Output signals	100		
2	Parameter list	104		
2-1	Application parameters.....	104		
2-2	System parameters	106		
3	Setting using the data setter.....	107		
3-1	Resolution	107		
3-2	Pulse input mode.....	109		
3-3	Motor excitation at power ON	111		
3-4	Automatic return operation.....	111		
3-5	Motor rotation direction	112		
3-6	Positioning completion signal offset.....	112		
4	Operation using a data setter	113		
4-1	Before operation	113		
4-2	Push-motion operation	114		
4-3	Test operation	117		
4-4	Return to electrical home operation	119		
5	Adjustment using the data setter	122		
5-1	Control mode	122		
5-2	Operating current.....	122		
5-3	Standstill current.....	123		
5-4	Speed filter	123		
5-5	Smooth drive.....	124		
5-6	Speed error gain.....	124		
5-7	Position loop gain, speed loop gain, speed loop integral time constant	125		
5-8	Anti-vibration control.....	125		
6	Operation using the OPX-2A	126		
6-1	Overview of the OPX-2A	126		
6-2	Names and functions of parts	127		
6-3	How to read the display	127		
6-4	OPX-2A error display	128		
6-5	Screen transitions	129		
6-6	Monitor mode	136		
6-7	Parameter mode	137		
6-8	Test mode	138		
6-9	Copy mode.....	139		
7	Inspection and maintenance	141		
7-1	Inspection.....	141		
7-2	Warranty.....	141		
7-3	Disposal.....	141		
8	Alarms and warnings	142		
8-1	Alarms.....	142		
8-2	Warnings.....	146		
9	Troubleshooting and remedial actions	148		

1 Explanation of I/O signals

1-1 Input signals

All input signals of the driver are photocoupler inputs. The signal state represents the "ON: Carrying current" or "OFF: Not carrying current" state of the internal photocoupler rather than the voltage level of the signal.

■ C-ON input

This signal is used to excite the motor. (initial value: normally open)

When an electromagnetic brake motor is used, release the electromagnetic brake after the motor is excited with the C-ON input.

With the **MEXE02** or **OPX-2A**, it is possible to set the C-ON input logic and the excitation position at the C-ON input ON. Refer to p.111 for details.

Note The factory setting of the C-ON input is normally open. Be sure to turn the C-ON input ON when operating the motor. Set the C-ON input to normally closed when the C-ON input is not used.

■ CW/PLS input, CCW/DIR input

These input serve as the CW and CCW inputs in the 2-pulse input mode, or PLS and DIR inputs in the 1-pulse input mode. They are common to all pulse input types including 5 VDC input, 24 VDC input and line driver input.

memo

- When no pulse is input, be sure to keep the photocoupler in the OFF state.
- The CW and CCW indicate the rotation direction of the motor, as seen from the output shaft. The output shaft of the **TH** geared typed motors with ratios of 20 and 30, as well as all ratios of the Harmonic geared type motors, rotate in the opposite direction of the motor shaft.

● 1-pulse input mode

- When the PLS input is turned ON while the DIR input is ON, the motor will rotate by one step in CW direction.
- When the PLS input is turned ON while the DIR input is OFF, the motor will rotate by one step in CCW direction.

* The minimum interval time needed for switching the direction of rotation will vary, depending on the operating speed and size of the load. Do not shorten the interval time more than necessary.

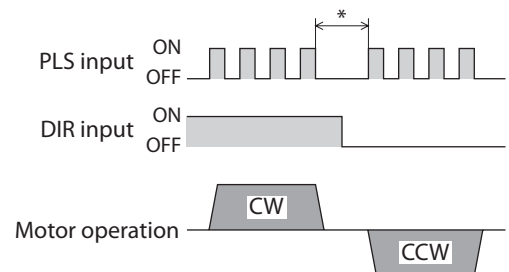

● 2-pulse input mode

- When the CW input is turned ON, the motor will rotate by one step in CW direction.
- When the CCW input is turned ON, the motor will rotate by one step in CCW direction.

* The minimum interval time needed for switching the direction of rotation will vary, depending on the operating speed and size of the load. Do not shorten the interval time more than necessary.

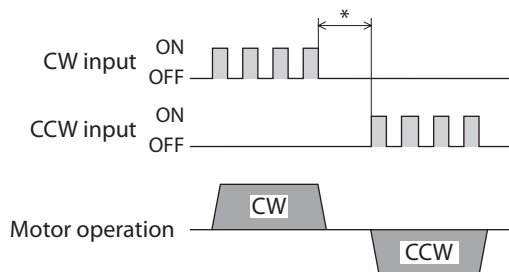

memo While one pulse is input, the other pulse should always be turned OFF. If both pulses are turned ON simultaneously, no pulse will be input.

● **Pulse signal**

Input a pulse with sharp rising and falling edges as shown in the figure.
The figure shows the voltage levels of pulse signals.

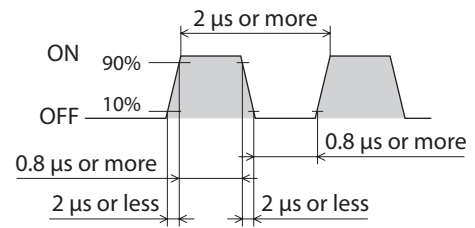

■ **FREE input**

When the FREE input is turned ON, current supplied to the motor will be cut off, thereby allowing the motor output shaft to be turned by external force. In the case of the AC power input type with an electromagnetic brake, the electromagnetic brake will also be released.

When the FREE input is turned OFF, current will be supplied to excite the motor and the holding torque will be restored.

The automatic return operation after turning the FREE input OFF can be set using the **MEXE02** or **OPX-2A**. Refer to p.111.

Note Do not turn the FREE input ON when driving a vertical load. Since the motor loses its holding torque, the load may drop.

Relations among the status of the FREE input, the C-ON input, and the motor output shaft are shown in the tables below.

AC power input type (motor without an electromagnetic brake), DC power input type

C-ON input \ FREE input	OFF	ON
OFF	Output shaft is in a released state	Output shaft is in a holding state by motor excitation
ON	Output shaft is in a released state	Output shaft is in a released state

AC power input type (motor with an electromagnetic brake)

C-ON input \ FREE input	OFF	ON
OFF	Output shaft is in a holding state by electromagnetic brake	Output shaft is in a holding state by motor excitation
ON	Output shaft is in a released state	Output shaft is in a released state

memo In the case of the DC power input type, the electromagnetic brake cannot be controlled with the FREE input. Control the electromagnetic brake by switching the ON/OFF status of the power supply for electromagnetic brake.

4 AC power input type/DC power input type Common

■ CS (T-MODE) input

The CS input is enabled when positioning operation is performed.

If the "I/O input mode" parameter of the application parameter is set to "PushMotion" using the **MEXE02** or **OPX-2A**, the T-MODE input will be enabled.

● CS input

When the Dip SW-No.3 is set to the left side (OFF), the resolution can be set as follows.

CS input \ Dip SW	Dip SW-No.3 is set to the left side (OFF) Dip SW-No.4 is set to the left side (OFF)	Dip SW-No.3 is set to the left side (OFF) Dip SW-No.4 is set to the right side (ON)
OFF	Selects the setting for when the No.3 is set to the left side (OFF). Factory setting: 1000 P/R	Selects the setting for when the No.3 is set to the left side (OFF). Factory setting: 500 P/R
ON	Selects the setting for when the No.3 is set to the right side (ON). Factory setting: 10000 P/R	Selects the setting for when the No.3 is set to the right side (ON). Factory setting: 5000 P/R



- When the Dip SW-No.3 is set to the right side (ON), the CS input is disabled. The setting for when the Dip SW-No.3 is set to the right side (ON) is kept.
- If the CS input is turned ON when the application parameter for abnormal operation data warning is set to "Enable," a return to electrical home operation will be disabled and an abnormal operation data warning will generate. When performing a return to electrical home operation after the CS input is turned ON, turn the P-RESET input ON to confirm the electrical home position and then turn the RETURN input ON.

● T-MODE input

When the T-MODE input is turned ON, the operating current changes to the push current,

■ RETURN (M1) input

The RETURN input is enabled when positioning operation is performed.

If the "I/O input mode" parameter of the application parameter is set to "PushMotion" using the **MEXE02** or **OPX-2A**, the M1 input will be enabled.

● RETURN input

When the RETURN input is turned ON, the motor will start a return to electrical home operation.

Return to electrical home operation is a type of operation that moves the motor to its electrical home position (where the cumulative value of command positions becomes "0").

The electrical home position is initially at the motor position when the power is turned on and it can be changed to a desired position using the P-RESET input.

● M1 input

Combine with the M0, M1 and M2 inputs to select a desired current setting for push-motion operation. Refer to p.114 for details.

■ P-RESET (M2) input

The P-RESET input is enabled when positioning operation is performed.

If the "I/O input mode" parameter of the application parameter is set to "PushMotion" using the **MEXE02** or **OPX-2A**, the M2 input will be enabled.

● P-RESET input

When the P-RESET input is turned ON, the cumulative value of command positions will become "0" and the electrical home position will be set. Input this signal while the motor is at standstill.

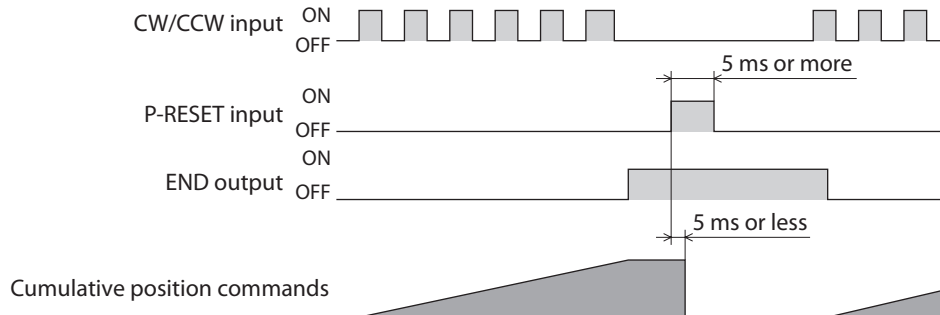

● M2 input

Combine with the M0, M1 and M2 inputs to select a desired current setting for push-motion operation. Refer to p.114 for details.

■ CLR/ALM-RST input

This input is used to clear the position deviation counter.

If an alarm generates, the CLR/ALM-RST input will function as an input signal to reset the alarm.

● CLR input

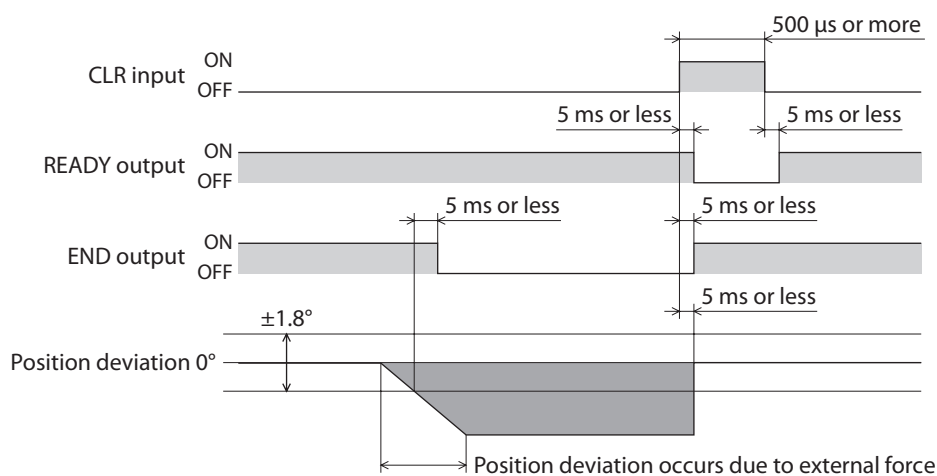

Note When performing a return to mechanical home operation using a stopper, etc., do not use the CLR input. If the CLR input is used, the home position may become offset.

memo

- Pulse input is disabled while the CLR input is ON.
- When the CLR input is turned ON, the automatic return operation and return to electrical home operation will stop.

● **ALM-RST input**

When an alarm generates, the ALM output will turn OFF. When the ALM-RST input is turned from ON to OFF, the ALM output will turn ON and the alarm will be reset. (The alarm will be reset at the OFF edge of the ALM-RST input.) Before resetting an alarm, always remove the cause of the alarm and ensure safety. For details, refer to "ALM output" on p.103, and "8-1 Alarms" on p.142.

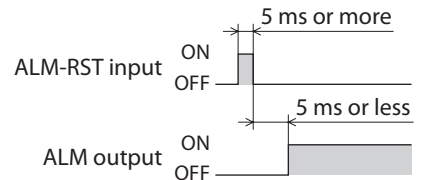

memo Alarms that cannot be reset with the ALM-RST input need to be reset by cycling the power. If a normal condition cannot be restored after cycling the power, contact your nearest Oriental Motor sales office.

■ **CCM input**

When the CCM input is turned ON, the control mode will change from the normal mode to the current control mode. In the current control mode, noise and vibration can be reduced although the motor synchronicity drops. Be sure to turn the CCM input ON/OFF after confirming that the motor has stopped.

memo Keep the Dip SW-No.2 in the left side (OFF). If the switch is in the right side (ON), the CCM input will be disabled.

■ **M0 input**

If the "I/O input mode" parameter of the application parameter is set to "PushMotion" using the **MEXE02** or **OPX-2A**, the M0 input will be enabled. Combine with the M0, M1 and M2 inputs to select a desired current setting for push-motion operation. Refer to p.114 for details.

1-2 Output signals

The driver outputs signals in the photocoupler/open-collector output mode or line driver output mode. The signal state represents the "ON: Carrying current" or "OFF: Not carrying current" state of the internal photocoupler rather than the voltage level of the signal.

memo The ASG output, BSG output and TIM1 output are line driver outputs. When connecting a line driver output, receive the output signal using a line receiver. Also, be sure to connect pins 2 or 21 of the driver to the GND on the line receiver, and connect a termination resistor of 100 Ω or more between the driver and the input of the line receiver.

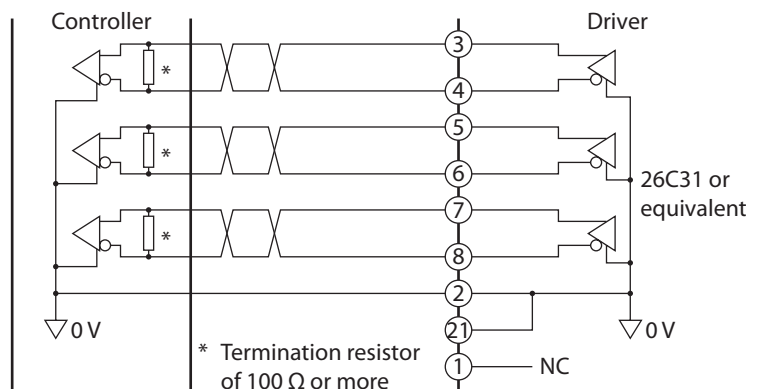

■ READY/AL0 output

When the driver becomes ready, the READY output turns ON. Input pulse signals to driver after the READY output has turned ON.

The READY output turns ON when all of the following conditions are satisfied.

- The main power supply and control power supply of the driver is turned ON.
- All input signals which start operation are OFF
- The C-ON input is turned ON.
- The STOP input is turned OFF.
- An alarm is not present.
- Test function or downloading was not performed using the **MEXE02**.
- Test operation, downloading or initializing was not performed using the **OPX-2A**.

If an alarm generates, an alarm code indicating the cause of the alarm can be output and checked via the combination of AL0, AL1 and AL2 outputs. To use alarm codes, the parameter must be changed using the **MEXE02** or **OPX-2A**. For details on alarm, refer to p.142.

■ TLC/AL1 output

This signal will be output when the torque characteristic exceeds the specified range. If a push current is set using the **MEXE02** or **OPX-2A**, this signal is output while pushing.

If an alarm generates, an alarm code indicating the cause of the alarm can be output and checked via the combination of AL0, AL1 and AL2 outputs. To use alarm codes, the parameter must be changed using the **MEXE02** or **OPX-2A**. For details on alarm, refer to p.142.

■ END output

When the motor has completed its movement, the END output will turn ON. Specifically, the END output will turn ON when the rotor position falls within $\pm 1.8^\circ$ of the command position while no pulse signal is input.

A desired output condition for the END signal can be set using the **MEXE02** or **OPX-2A**. Refer to p.112.

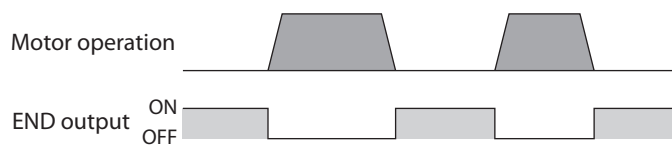

* The output time of the END signal varies depending on the speed filter and operating speed.

■ TIM1 output

The TIM output will turn ON every time the motor output shaft rotates by 7.2° .

Two types of TIM outputs are available: the line driver output (TIM1 output), and the open collector output (TIM2 output). Connect the TIM output according to the pulse input mode of the programmable controller.

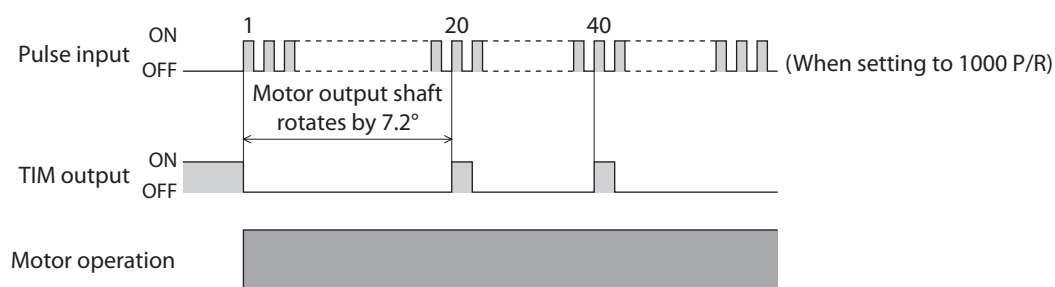

- The TIM1 output will turn ON when the pulse speed is 10 kHz or less, and the TIM2 output will turn ON when the pulse speed is 500 Hz or less.
- Connect a termination resistor of 100 Ω or more between the driver and the input of the line receiver.
- When changing the resolution using the CS input, do so while the TIM output is ON and the motor is at standstill. If the CS input is turned ON/OFF when one or both of these conditions are unsatisfied, the TIM output will not turn ON even after the motor output shaft rotates by 7.2° .

■ TIM2/AL2 output

Refer to "TIM1 output" for the TIM2 output.

If an alarm generates, an alarm code indicating the cause of the alarm can be output and checked via the combination of AL0, AL1 and AL2 outputs. To use alarm codes, the parameter must be changed using the **MEXE02** or **OPX-2A**. For details on alarm, refer to p.142.

■ ASG output, BSG output

The ASG output is used to output pulses according to motor operation. The motor position can be monitored by counting the ASG output pulses. The number of output pulses per motor revolution varies depending on the resolution effective when turning the power on.

The BSG output has a 90° phase difference with respect to the ASG output. The motor rotation direction can be determined by detecting the BSG output level at the rise of the ASG output.

Regardless of the resolution, the accuracy of the pulse output is in a range of ±0.36°.

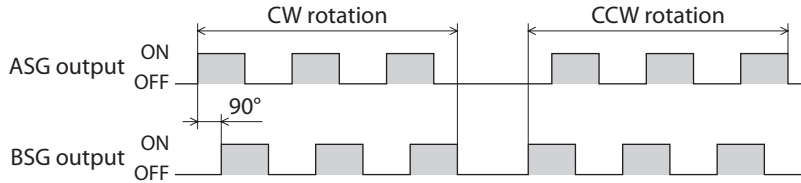

- The ASG output and BSG output are subject to a maximum delay of 0.1 ms with respect to motor operation. Use these outputs to check the position at which the motor is stopped.
- Even if the motor rotation direction is changed with the parameter, the determination method of the rotation direction by the ASG output and the BSG output does not change.
- Connect a termination resistor of 100 Ω or more between the driver and the input of the line receiver.

Electrical characteristics of ASG output and BSG output

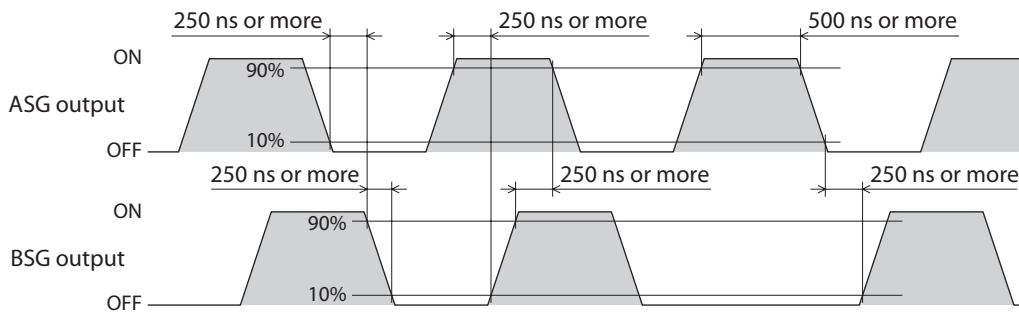

The electrical characteristics vary depending on the IC specification of the line driver.

■ ALM output

When an alarm generates, the ALM output will turn OFF. At the same time, the ALARM LED of the driver will blink and the motor current will be cut off and stop. *

In the case of an electromagnetic brake motor, the electromagnetic brake will switch to the holding mode.

Set the programmable controller so that it will stop motor operation commands upon detection of an OFF status of the ALM output.

The cause of the alarm can be checked by counting the number of times the ALARM LED blinks. For details, refer to p.142.

* Abnormal operation data alarm is not supported by this function. (because the current will not be cut off even after these errors occur.)

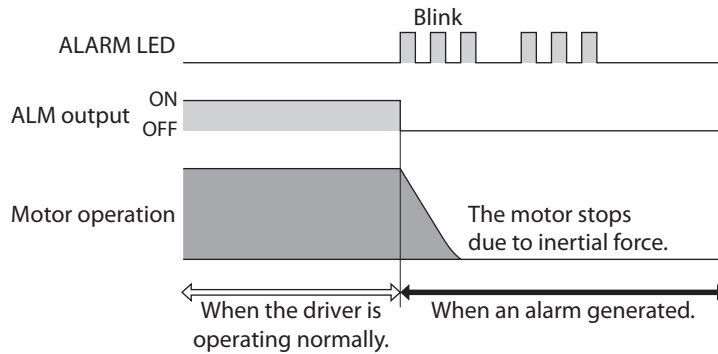

■ WNG output

When a warning generates, the WNG output turns ON. To use the WNG output, change the output condition of the warning using the **MEXE02** or **OPX-2A**. Since the initial value is to use the same conditions applicable to alarms, the warnings will not be output if the setting remains the initial value. For details on warning, refer to p.146.

2 Parameter list

Using the **MEXE02** or **OPX-2A**, the driver parameters can be changed, and also test operation and monitoring operations can be performed. The key functions are listed below.

2-1 Application parameters

MEXE02 tree view	Parameter name	Description	Setting range
Operation current	Operating current setting 0 to F	Sets each operating current rate assigned to the CURRENT switch.	0.0 to 100.0%
Speed filter	Speed filter setting 0 to F	Sets each filter time constant assigned to the V-FIL switch.	0 to 200 ms
I/O	I/O input mode	Selects the input signal mode.	0: Positioning operation 1: PushMotion
	Alarm code output	Changes the setting to enable/disable alarm code output.	0: Disable 1: Enable
	C-ON signal logic	Changes the C-ON input logic.	0: Normally open 1: Normally closed
	END signal range	Sets the output condition for END output.	0.0 to 18.0°
	Positioning complete output offset	If the position at which the motor stops deviates from the theoretical position due to the effect of the load, friction, etc., set an offset for the output position corresponding to the END output.	-1.8 to 1.8°
	Push current setting 0 to 7	Sets the operating current rate applicable to push-motion operation.	0.0 to 100.0%
Normal mode	Standstill current	Sets the standstill current as a percentage of the operating current.	0.0 to 50.0%
	Speed difference gain 1	Sets the speed error gain. When this value is increased, motor vibration will decrease.	0 to 500
	Speed difference gain 2	Sets the speed error gain. When this value is increased, motor vibration at the time of speed change will decrease.	0 to 500
Operation current	Position loop gain	Sets the position loop gain. When this value is increased, the response will increase and motor overshoot will decrease.	1 to 50
	Speed loop gain	Sets the speed loop gain. When this value is increased, the response will increase and motor overshoot will decrease.	10 to 200
	Speed loop integral time constant	Sets the integral time constant for speed loop. When this value is decreased, the response will increase and motor overshoot will decrease.	10.0 to 200.0 ms
	Anti-vibration control	Changes the setting to enable/disable anti-vibration control.	0: Disable 1: Enable
	Frequency of anti-vibration control	Sets the frequency of anti-vibration control.	3.00 to 100.00 Hz

MEXE02 tree view	Parameter name	Description	Setting range
Alarm/warning	Abnormal operation data warning	Generates the abnormal operation data warning.	0: Disable 1: Enable
	Excessive position deviation alarm at current ON	Sets the condition in which an alarm generates.	0.01 to 300.00 rev
	Excessive position deviation warning during current OFF	Sets the condition in which a warning generates.	0.01 to 300.00 rev
	Overload alarm	Sets the condition in which an alarm generates.	0.1 to 30.0 s
	Excessive position deviation warning at current ON	Sets the condition in which a warning generates.	0.01 to 300.00 rev
	Overvoltage warning	Sets the condition in which a warning generates.	AC power input: 320 to 450 V DC power input: 15.0 to 63.0 V
	Undervoltage warning	Sets the condition in which a warning generates.	AC power input: 120 to 280 V DC power input: 15.0 to 63.0 V
	Overheat warning	Sets the condition in which a warning generates.	40 to 85 °C
	Overload warning	Sets the condition in which a warning generates.	0.1 to 30.0 s
	Overspeed warning	Sets the condition in which a warning generates.	1 to 5000 r/min
Return to electrical home operation	Operating speed of return to electrical home operation	Sets the operating speed of return to electrical home operation.	1 to 4000 r/min
	Acceleration/ deceleration rate of return to electrical home operation	Sets the acceleration and deceleration rate of return to electrical home operation.	0.01 to 1000.00 ms/ (1000 r/min)
	Starting speed of return operation	Sets the starting speed of return to electrical home operation.	0 to 4000 r/min
Manual operation	JOG operating speed	Sets the operating speed of JOG operation.	1 to 4000 r/min
	Acceleration and deceleration rate of JOG operation	Sets the acceleration and deceleration rate of JOG operation.	0.01 to 1000.00 ms/ (1000 r/min)
	Starting speed of JOG operation	Sets the starting speed of JOG operation.	0 to 4000 r/min
OPX-2A	Data setter speed display	Sets the speed on the OPX-2A with a sign or as an absolute value.	0: Signed 1: Absolute value
	Deceleration rate of speed monitor	Sets the gear ratio for geared motor used for speed monitor.	1.0 to 100.0
	Data setter edit	Sets whether it is possible to edit using the OPX-2A .	0: Disable 1: Enable

2-2 System parameters

MEXE02 tree view	Parameter name	Description	Setting range
Electronic gear	Electronic gear A1 to A4	Sets the denominator of the electronic gear.	1 to 1000
	Electronic gear B	Sets the numerator of the electronic gear.	1 to 1000
Operation	Pulse input mode	Selects the pulse input mode.	0: Setting by the pulse input mode select switch 1: 2-pulse input mode, low active 2: 2-pulse input mode, high active 3: 1-pulse input mode, low active 4: 1-pulse input mode, high active 5: following input ×1 6: following input ×2 7: following input ×4
	Smooth drive	Changes the setting to enable/disable the smooth drive.	0: Disable 1: Enable
	Excite position at first current on	Selects the position at which the motor is excited after the power has been turned on.	0: Detected position 1: Electrical angle 0°
	Auto return	Sets whether or not to automatically return the motor, when the current is turned on, to the position where it was stopped.	0: Disable 1: Enable
	Motor rotation direction	Selects rotation direction of the motor.	0: Positive=CCW 1: Positive=CW



When a system parameter is changed, the new parameter will be enabled after the power is cycled. If a 24 VDC power supply is used with the AC power input type, also cycle the 24 VDC power supply.

3 Setting using the data setter

This chapter explains items that can be set using the **MEXE02** or **OPX-2A**.

3-1 Resolution

4 resolutions can be set with the "Electronic gear" parameter of the system parameter. Select the set resolution with the Dip SW-No.3 and No.4.

Check that all of the 4 resolutions satisfy the setting range.

Resolution setting range: 100 to 10000 P/R

Factory setting: 1000 P/R

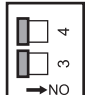
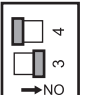
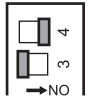
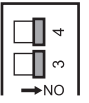
Dip SW	No.3 is set to the left side (OFF)	No.3 is set to the right side (ON)
No.4 is set to the left side (OFF)	 $1000 \times \frac{\text{Electronic gear B}}{\text{Electronic gear A1}}$	 $1000 \times \frac{\text{Electronic gear B}}{\text{Electronic gear A2}}$
No.4 is set to the right side (ON)	 $1000 \times \frac{\text{Electronic gear B}}{\text{Electronic gear A3}}$	 $1000 \times \frac{\text{Electronic gear B}}{\text{Electronic gear A4}}$



- When a system parameter is changed, the new parameter will be enabled after the power is cycled. If a 24 VDC power supply is used with the AC power input type, also cycle the 24 VDC power supply.
- If the calculated resolution exceeds the setting range, an electronic gear setting error warning will generate. In addition to the setting of the resolution presently being used, check all settings of the 4 resolutions in the table above. For details, refer to p.146.
- If the power is cycled while an electronic gear setting error warning is present, an electronic gear setting error alarm will generate. Refer to p.142.

Related parameter

MEXE02 tree view	Parameter name	Description	Initial value
Electronic gear	Electronic gear A1	Sets the denominator of the electronic gear.	10
	Electronic gear A2	4 resolutions can be set with a combination of the Dip SW-No.3 and 4. [Setting range] 1 to 1000	1
	Electronic gear A3		20
	Electronic gear A4	2	
	Electronic gear B	Sets the numerator of the electronic gear. [Setting range] 1 to 1000	10

■ Calculation of electronic gear

Calculation of electronic gear A1 and B is explained with examples of a ball screw and rotary table. Set the Dip SW-Nos.3 and 4 to the left side (OFF) to select the electronic gear A1.

● Example 1) Ball screw

Ball screw lead: 12 mm

Minimum travel amount: 0.01 mm

Gear ratio: 1 (No speed reduction mechanism between motor and ball screw)

$$\text{Resolution} = 1000 \times \frac{\text{Electronic gear B}}{\text{Electronic gear A1}} = \frac{\text{Ball screw lead}}{\text{Minimum travel amount}} \times \text{Gear ratio}$$

$$\text{In this example: } 1000 \times \frac{\text{Electronic gear B}}{\text{Electronic gear A1}} = \frac{12 \text{ mm}}{0.01 \text{ mm}} \times 1$$

$$\text{Result: } \frac{\text{Electronic gear B}}{\text{Electronic gear A1}} = \frac{12}{10}$$

Therefore, the electronic gear A1 and B are 10 and 12 respectively, and the resolution will be 1200 P/R.

● Example 2) Rotary table

Step angle per one rotation: 360°

Minimum step angle: 0.01°

Gear ratio: 10 [Using the geared motor (gear ratio 10:1)]

$$\text{Resolution} = 1000 \times \frac{\text{Electronic gear B}}{\text{Electronic gear A1}} = \frac{\text{Step angle per one rotation}}{\text{Minimum step angle}} \times \text{Gear ratio}$$

$$\text{In this example: } 1000 \times \frac{\text{Electronic gear B}}{\text{Electronic gear A1}} = \frac{360^\circ}{0.01^\circ} \times \frac{1}{10}$$

$$\text{Result: } \frac{\text{Electronic gear B}}{\text{Electronic gear A1}} = \frac{36}{10}$$

Therefore, the electronic gear A1 and B are 10 and 36 respectively, and the resolution will be 3600 P/R.



If the CS input is turned ON while the "Abnormal operation data warning" parameter of the application parameter is set to "Enable," return-to-electrical home operation cannot be performed, and the abnormal operation data warning will generate. When return-to-electrical home operation is performed after the CS input is turned ON, set the electrical home position by turning the P-RESET input ON before turning the RETURN input ON.

3-2 Pulse input mode

Set the desired pulse input mode of the driver according to the pulse output mode of the controller (pulse generator) used with the driver. Set a desired mode using the system parameter for pulse input mode.

- 1-pulse input mode
A pulse signal is input via the PLS input and the rotation direction is selected using the DIR input.
- 2-pulse input mode
When a pulse signal is input via the CW input, the motor will rotate in forward direction. If a pulse signal is input via the CCW input, the motor will rotate in reverse direction.
- Phase difference input mode (set by a parameter)
The motor will rotate in forward direction when the CCW input phase is delayed by 90° relative to the CW input.
The motor will rotate in reverse direction when the CCW input phase is advanced by 90° relative to the CW input.

Related parameter

MEXE02 tree view	Parameter name	Description	Initial value
Operation	Pulse input mode	Selects the pulse input mode. [Setting range] 0: Setting by the pulse input mode select switch 1: 2-pulse input mode, low active 2: 2-pulse input mode, high active 3: 1-pulse input mode, low active 4: 1-pulse input mode, high active 5: following input x1 6: following input x2 7: following input x4	0

Whether to cause the motor to rotate in CW direction or CCW direction when a forward direction pulse is input can be set using the system parameter for rotation direction. Refer to p.112.

memo When a system parameter is changed, the new parameter will be enabled after the power is cycled. If a 24 VDC power supply is used with the AC power input type, also cycle the 24 VDC power supply.

Pulse input mode	Input pattern	Timing chart
1-pulse input mode	Active high	<p>0.8 μs or more</p> <p>0.8 μs or more</p> <p>PLS input ON OFF</p> <p>DIR input ON OFF</p> <p>Rotation direction Forward rotation Reverse rotation</p>
	Active low	<p>0.8 μs or more</p> <p>0.8 μs or more</p> <p>PLS input ON OFF</p> <p>DIR input ON OFF</p> <p>Rotation direction Forward rotation Reverse rotation</p>

4 AC power input type/DC power input type Common

Pulse input mode	Input pattern	Timing chart
2-pulse input mode	Active high	<p>CW input ON OFF CCW input ON OFF Rotation direction Forward rotation Reverse rotation 0.8 μs or more</p>
	Active low (initila value)	<p>CW input ON OFF CCW input ON OFF Rotation direction Forward rotation Reverse rotation 0.8 μs or more</p>
Phase difference input mode	Following input ×1	<p>CW input ON OFF CCW input ON OFF Rotation direction Forward rotation Reverse rotation 0.4 μs or more</p>
	Following input ×2	<p>CW input ON OFF CCW input ON OFF Rotation direction Forward rotation Reverse rotation 0.4 μs or more</p>
	Following input ×4	<p>CW input ON OFF CCW input ON OFF Rotation direction Forward rotation Reverse rotation 0.4 μs or more</p>

■ Pulse signal

Input a pulse with sharp rising and falling edges as shown in the figures. The figure shows the voltage levels of pulse signals.

● 1-pulse input mode, 2-pulse input mode

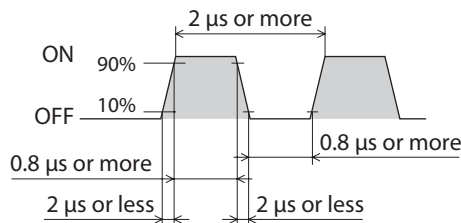

● Phase difference input mode

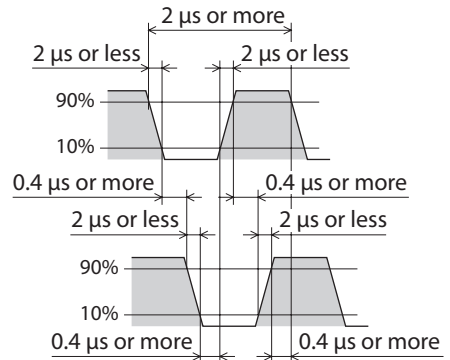

3-3 Motor excitation at power ON

When the power is turned on and the C-ON input switched ON, the motor will be excited at the current position. If the system parameter for excite position at first current on is set to "electrical angle 0°," the motor will be excited at the position corresponding to electrical angle 0° (where the TIM output turns ON).

If the C-ON input is set to normally closed, however, the motor will be excited automatically at the electrical angle 0° position after the power has been turned on.

The C-ON input logic can be set using the application parameter for C-ON input logic.

- memo**
- If the parameter for excite position at first current on is set to "electrical angle 0°," the motor output shaft may move by a maximum of 3.6° when the C-ON input is turned ON.
 - When a system parameter is changed, the new parameter will be enabled after the power is cycled. If a 24 VDC power supply is used with the AC power input type, also cycle the 24 VDC power supply.

Related parameter

MEXE02 tree view	Parameter name	Description	Initial value
I/O	C-ON signal logic	Sets the C-ON input logic. [Setting range] 0: Normally open 1: Normally closed	0
Operation	Excite position at first current on	Sets the position at which the motor is excited after the power has been turned on. [Setting range] 0: Detected position 1: Electrical angle 0°	0

3-4 Automatic return operation

When a position deviation occurs by an external force while the motor is in a non-excitation state, the motor can automatically return to the position where the motor last stopped.

Set the system parameter for auto return to "enable."

Automatic return operation will be executed under the following conditions;

- When the main power is turned on. (AC power input only)
- When the C-ON input is turned from OFF to ON.
- When the FREE input is turned from ON to OFF.

- memo**
- When a system parameter is changed, the new parameter will be enabled after the power is cycled. If a 24 VDC power supply is used with the AC power input type, also cycle the 24 VDC power supply.

Related parameter

MEXE02 tree view	Parameter name	Description	Initial value
Operation	Auto return	Set whether or not to return the motor to its excitation position (where the deviation becomes "0") when the current is turned on. [Setting range] 0: Disable 1: Enable	0

3-5 Motor rotation direction

Set a motor rotation direction using the system parameter for motor rotation direction.

- memo**
- When a system parameter is changed, the new parameter will be enabled after the power is cycled. If a 24 VDC power supply is used with the AC power input type, also cycle the 24 VDC power supply.
 - The CW and CCW indicate the rotation direction of the motor, as seen from the output shaft. The output shaft of the **TH** geared typed motors with ratios of 20 and 30, as well as all ratios of the Harmonic geared type motors, rotate in the opposite direction of the motor shaft.

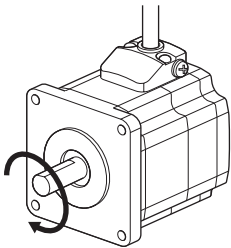
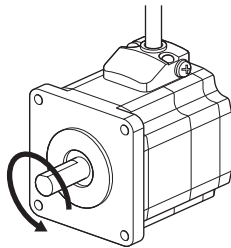
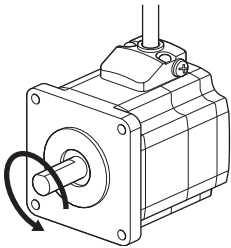
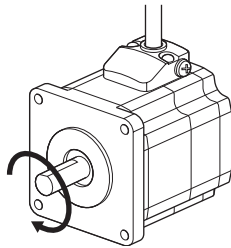
Setting of motor rotation direction parameter	CW pulse is input	CCW pulse is input
When "positive=CW" is set	<ul style="list-style-type: none"> • The command position increases. • The motor rotates in CW direction. 	<ul style="list-style-type: none"> • The command position decreases. • The motor rotates in CCW direction. 
When "positive=CCW" is set	<ul style="list-style-type: none"> • The command position increases. • The motor rotates in CCW direction. 	<ul style="list-style-type: none"> • The command position decreases. • The motor rotates in CW direction. 

Related parameter

MEXE02 tree view	Parameter name	Description	Initial value
Operation	Motor rotation direction	Sets the rotation direction of the motor [Setting range] 0: Positive=CCW 1: Positive=CW	1

3-6 Positioning completion signal offset

The motor stops at the theoretical stopping position as a center point or thereabout. If the motor stops at a position deviated from the theoretical stopping position due to the load, friction, etc., and the deviation band exceeds the specified END signal range, the END output will not turn ON. In this case, use the application parameter for END signal range to compensate the deviation band.

Related parameter

MEXE02 tree view	Parameter name	Description	Initial value
I/O	END signal range	Sets an offset for the output position corresponding to the END output. [Setting range] -1.8 to 1.8°	0.0

4 Operation using a data setter

This chapter explains how to perform 3 types of operations (push-motion operation, test operation, return-to-electrical home operation) using the **MEXE02**. The figure explains using the AC power input type driver.

4-1 Before operation

1. Connect the motor, power supply, I/O signals and PC in which the **MEXE02** has been installed to the driver.

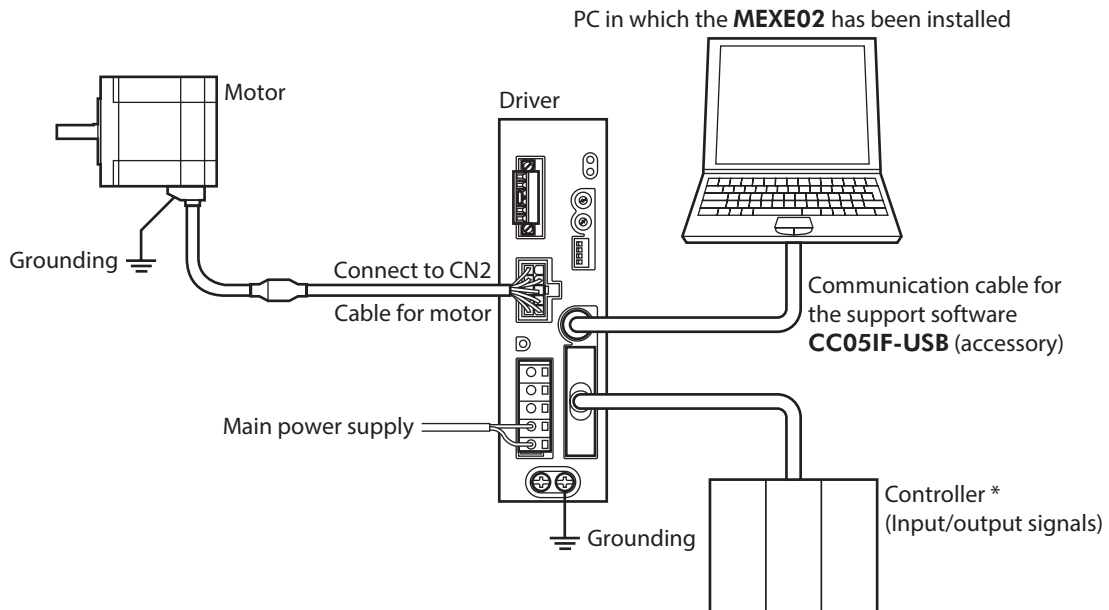

* This explains using the following I/O signals.

Pin No.	I/O signal	Signal name
17	TLC+	Torque limit output
18	TLC-	
23	C-ON	Current on input
24	CLR	Deviation clear input
26	T-MODE	Push-motion operation ON
31	CW+	CW pulse input (+5 V or line driver)
32	CW-	
33	CW+24 V	CW pulse input (+24 V)
34	CCW+24 V	CCW pulse input (+24 V)
35	CCW+	CCW pulse input (+5 V or line driver)
36	CCW-	

2. Turn on the main power supply.
 3. Start a PC, and continuously start the **MEXE02**.
Refer to the **MEXE02 OPERATING MANUAL** for how to start or use the **MEXE02**.
- It is now ready to operate.

4-2 Push-motion operation

Push-motion operation is a type of operation where pulses are input to pressurize the load continuously. When selecting a push-motion operation with the application parameter for I/O input mode, turning the T-MODE input ON and inputting pulses, push-motion operation will start. Pulses will be continuously input and accumulate even when the load is balanced with the torque.



Do not perform push-motion operation with geared type motors. Doing so may cause damage to the motor or gear part.

■ STEP 1: Setting the parameter

● Selecting the push-motion operation mode

Set the application parameter for I/O input mode to "PushMotion."

The pin No.26 to No.29 of the I/O signal connector (CN5) switch to the push-motion operation mode.

Pin No.	Positioning operation		Push-motion operation	
	26	CS	Resolution selection input	T-MODE
27	-	-	M0	Push-current setting selection input
28	RETURN	Return to electrical home operation	M1	
29	P-RESET	Position reset input	M2	

← These signals are enabled.

Related parameter

MEXE02 tree view	Parameter name	Description	Initial value
I/O	I/O input mode	Selects the input signal mode. [Setting range] 0: Positioning operation 1: PushMotion	0

● Setting the current for push-motion operation

When the torque is limited in the push-motion operation, set the application parameters for push current setting 0 to 7.

The current value set in the parameter will be used to limit the output torque. Set based on the rated current being 100%.

8 values can be set. You can select a desired current setting by a combination of ON/OFF statuses of M0 to M2 inputs.

Example) When you want to limit the output torque to 50%, set the push current to 50%.

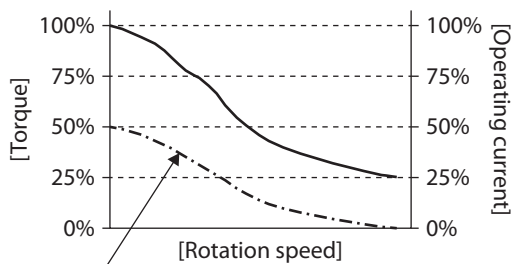

Torque characteristic for when the torque value of push-motion operation is limited to 50%

Related parameter

MEXE02 tree view	Parameter name	Description	Initial value
I/O	Push current setting 0	Limits the output torque of push-motion operation. Set based on the rated current being 100%. [Setting range] 0.0 to 100.0%	30.0
	Push current setting 1		40.0
	Push current setting 2		50.0
	Push current setting 3		60.0
	Push current setting 4		70.0
	Push current setting 5		80.0
	Push current setting 6		90.0
	Push current setting 7		100.0

Selection of push current

You can select a desired current setting by a combination of ON/OFF statuses of M0 to M2 inputs.

Push current setting parameter	M2	M1	M0
0	OFF	OFF	OFF
1	OFF	OFF	ON
2	OFF	ON	OFF
3	OFF	ON	ON
4	ON	OFF	OFF
5	ON	OFF	ON
6	ON	ON	OFF
7	ON	ON	ON

● **Writing data**

The data created in the **MEXE02** can be written to the driver.

1. Click the [Data writing] icon in the toolbar.



2. Select data to be written and click [OK].

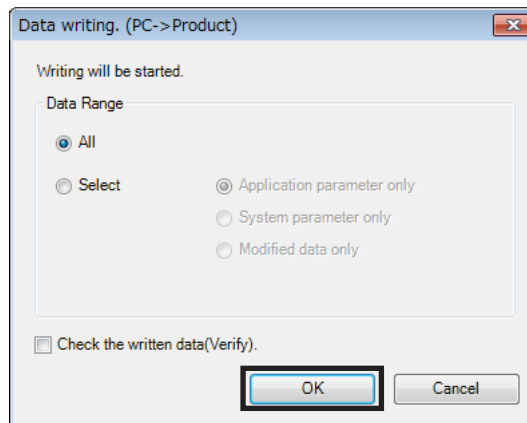

3. Click [YES].
Data writing starts.

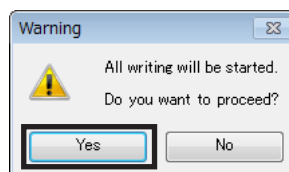

4. After it is completed, click [OK].

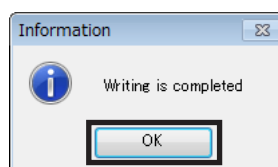

■ STEP 2: Performing the push-motion operation

This example explains how to perform push-motion operation in the CW direction with the initial value (30%) of the push current setting 0.

1. Turn the C-ON input ON.
2. Select the push current based on a combination of ON/OFF status of the M0 to M2 inputs.
Here, turn all the M0 to M2 inputs OFF to select the push current setting 0.
3. Operate the motor until the starting position of push-motion.
4. Turn the T-MODE input ON to set the push-motion operation mode.

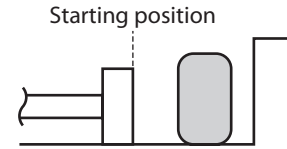

5. Turn the CW input ON to start push-motion in the CW direction.
The TLC output is turned ON while push-motion operation is performed.

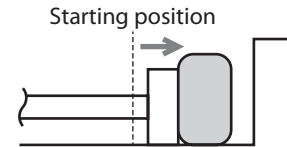

6. When push-motion is completed, turn the CW input OFF.
7. Return the motor to the starting position of push-motion by inputting the number of pulses, which was input to the CW input, to the CCW input.
8. Turn the T-MODE input OFF.
The push-motion operation mode is completed.

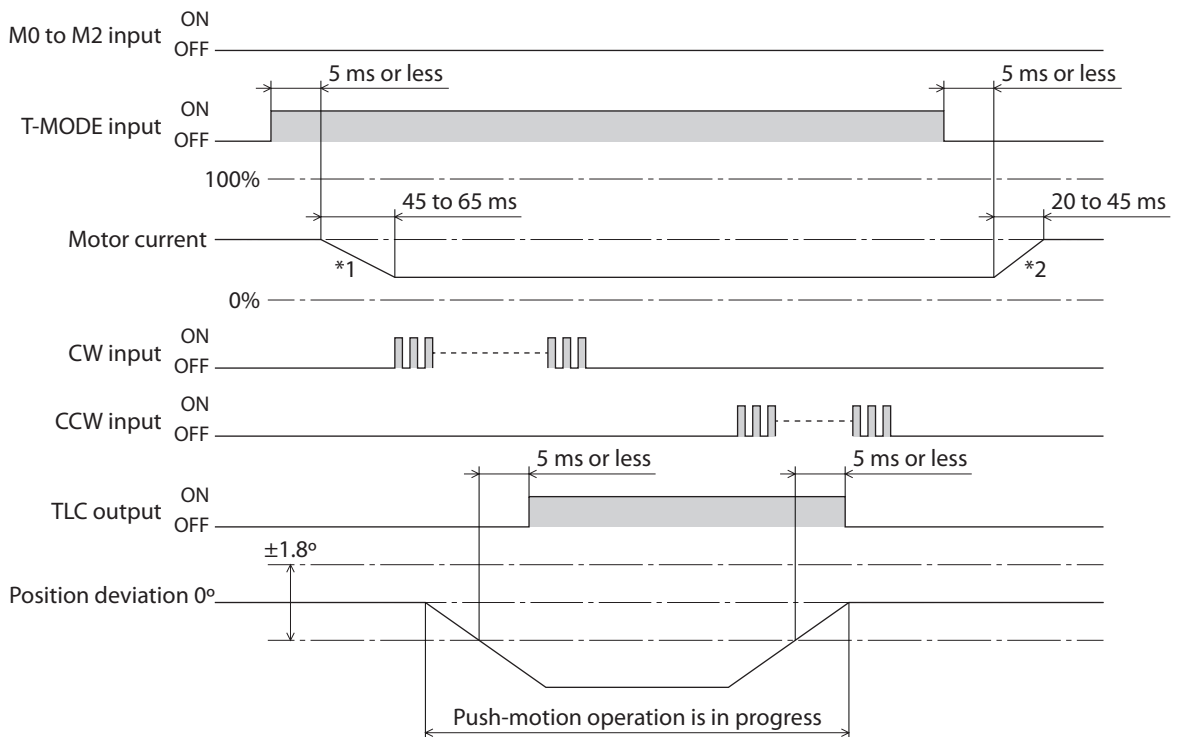
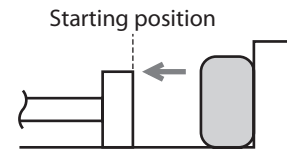
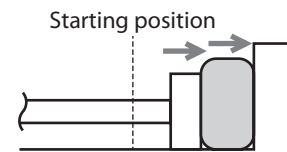

*1 When the T-MODE is ON, the motor current rises to the push current at a rate of approximately 0.9%/ms.

*2 When the T-MODE is OFF, the motor current drops to the standstill current at a rate of approximately 1.8%/ms.

Note

- During push-motion operation, the automatic current cutback function does not operate even when the pulse input is stopped. In other words, the value of push current selected for the parameter is maintained.
- If the load is removed during push-motion operation, the motor will move at high speed the number accumulated pulses.
- Since pulses are input continuously during push-motion operation, a prolonged push condition may generate an excessive position deviation alarm. If the push condition continues for a prolonged period, stop the pulse input. Whether or not the motor is pushing the load can be determined using the TLC output.

memo

The overload alarm does not generate while the T-MODE input is being ON.

■ **Push current and standstill current**

The current cutback function does not operate while the push-motion operation mode is performed by turning the T-MODE input ON. Even if the operation is stopped, the current does not drop and it keeps the push current. If the T-MODE input is turned OFF to change to the positioning operation mode, the current drops to the standstill current by the automatic current cutback function. To suppress a heat generation, turn the T-MODE input OFF when the push current is higher than the standstill current.

4-3 Test operation

The motor can be operated without inputting pulses in test operation. Conduct test operation to check the levels of vibration and noise or to check how operations are performed in a push-motion operation and/or a return to electrical home operation.

■ **Operating method**

1. Click the [Remote operation] icon in the toolbar or click the [Remote operation] short-cut button.

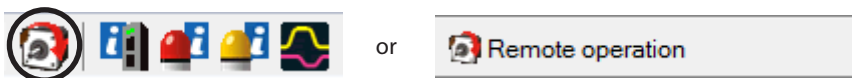

The remote operation window appears.

2. Turn the C-ON input to ON.
3. Click "Start the remote operation."

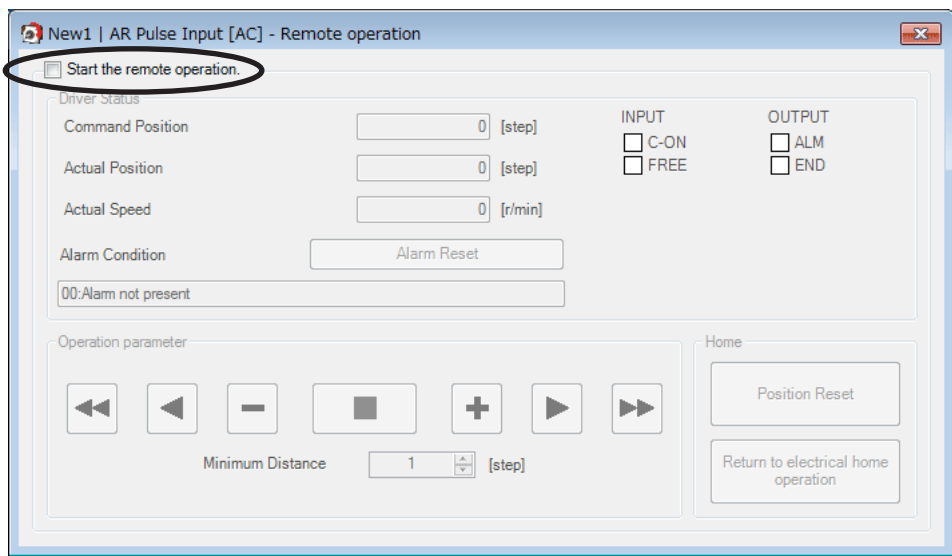

- Click [Yes] on the pop-up window (Warning).

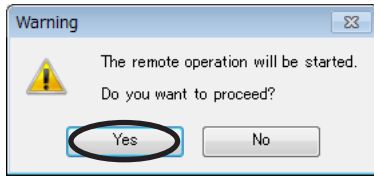

- Operate the motor using the JOG operation buttons.

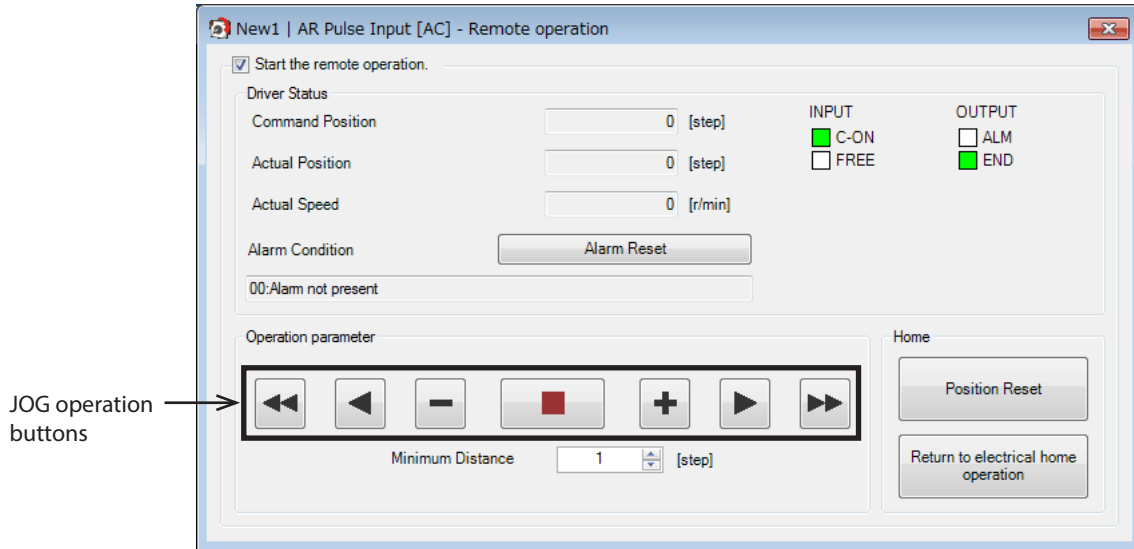

	Moves the motor in the negative direction at the JOG operating speed.
	Moves in the negative direction at the speed of one-tenth of the JOG operating speed.
	Moves the motor in the negative direction by the minimum distance.
	Stops the operation immediately.
	Moves the motor in the positive direction by the minimum distance.
	Moves in the positive direction at the speed of one-tenth of the JOG operating speed.
	Moves the motor in the positive direction at the JOG operating speed.

- To end the test operation, unselect "Start the remote operation."

memo Test operation is performed only while each applicable operation button is clicked in **MEXE02**. External signals cannot be used to start/stop the motor.

■ How to change the operating condition

1. Change the operating condition of test operation with 3 parameters in the table.
2. Refer to p.115, and write the changed parameter to the driver.

Related parameter

MEXE02 tree view	Parameter name	Description	Initial value
Manual operation	JOG operating speed	Sets the operating speed of JOG operation. [Setting range] 1 to 4000 r/min	30
	Acceleration and deceleration rate of JOG operation	Sets the acceleration and deceleration rate of JOG operation. [Setting range] 0.01 to 1000.00 ms/(1000 r/min)	100.00
	Starting speed of JOG operation	Sets the starting speed of JOG operation. [Setting range] 0 to 4000 r/min	30

4-4 Return to electrical home operation

When the RETURN input is turned ON, the motor will start a return to electrical home operation. The electrical home (position) refers to the motor position effective when the driver power is turned on, or the position when the P-RESET input is turned ON.

■ STEP 1: Check the present position

1. Click the [Remote operation] icon in the toolbar or click the [Remote operation] short-cut button.

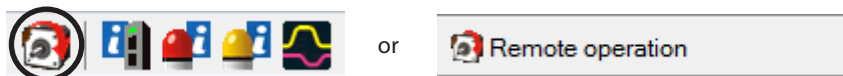

The remote operation window appears.

2. Turn the C-ON input to ON.
3. Click "Start the remote operation."

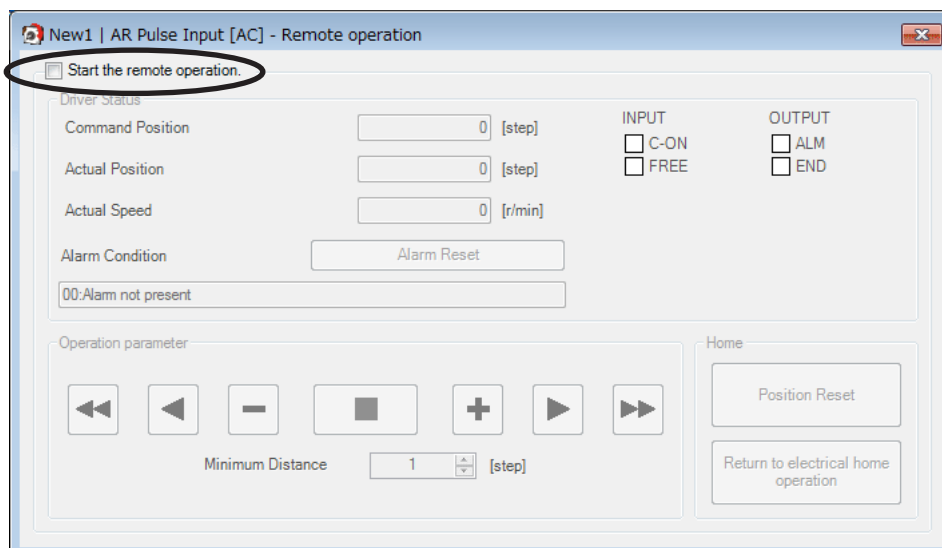

- Click [Yes] on the pop-up window (Warning).

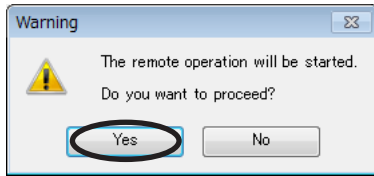

- Check the value in the "Actual Position" of the Driver Status.

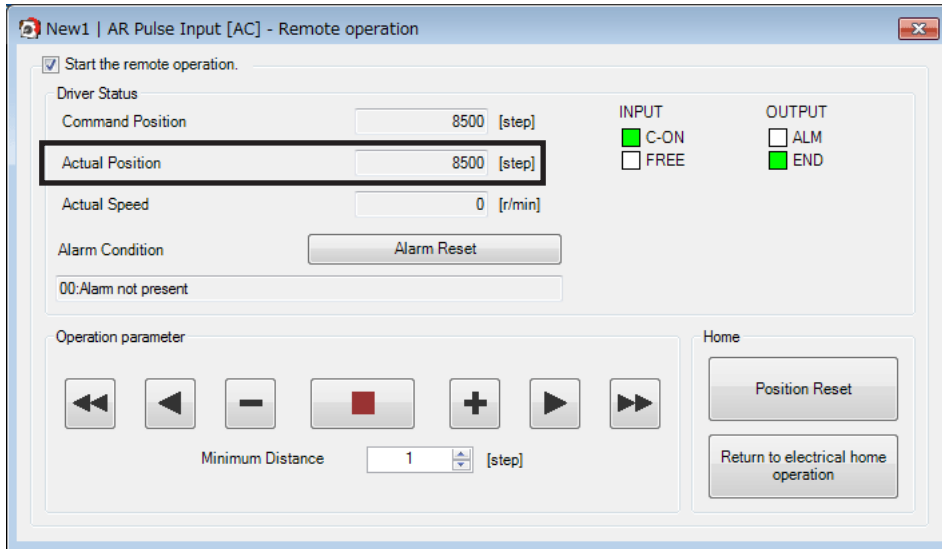

■ STEP 2: Perform electrical home operation

- Click [Return to electrical home operation].

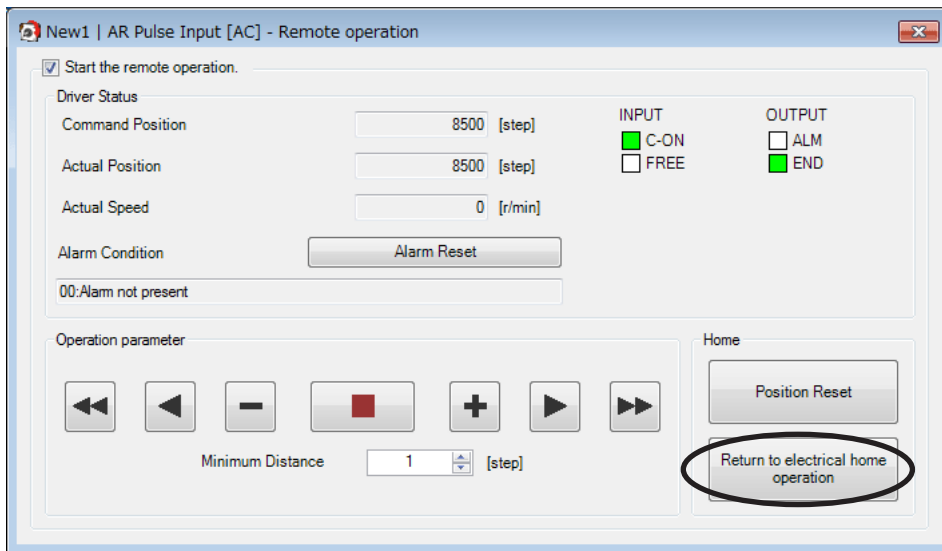

- Click [Yes] on the pop-up window (Warning).
Return to electrical home operation will be started.

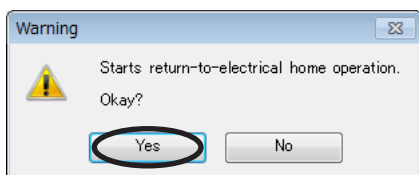

3. After return-to-electrical home operation is complete, check that the "Actual Position" of the Driver Status has changed to 0.

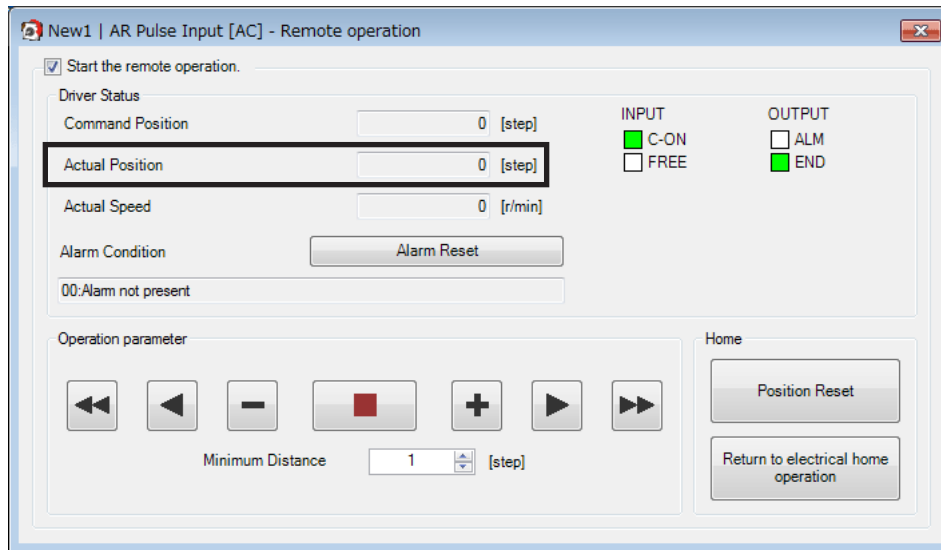

4. To end the test operation, unselect "Start the remote operation."



- Pulses are not counted during return to electrical home operation.
- If the CS input is turned ON when the application parameter for abnormal operation data warning is set to "enable," a return to electrical home operation will be disabled and an abnormal operation data warning will generate. If a return to electrical home operation is to be performed after the CS input is turned ON, turn the P-RESET input ON to confirm the electrical home position and then turn the RETURN input ON.
- Turning the P-RESET input ON while a return to electrical home operation is still in progress will set the applicable position as the electrical home, and the motor will stop.

■ How to change the operating condition

1. Change the operating condition of test operation with 3 parameters in the table.
2. Refer to p.115, and write the changed parameter to the driver.

Related parameter

MEXE02 tree view	Parameter name	Description	Initial value
Return to electrical home operation	Operating speed of return to electrical home operation	Sets the operating speed of return to electrical home operation. [Setting range] 1 to 4000 r/min	30
	Acceleration/deceleration rate of return to electrical home operation	Sets the acceleration and deceleration rate of return to electrical home operation. [Setting range] 0.01 to 1000.00 ms/(1000 r/min)	100.00
	Starting speed of return operation	Sets the starting speed of return to electrical home operation. [Setting range] 0 to 4000 r/min	30

5 Adjustment using the data setter

The operating current, motor operation at start/stop, and response in reaction to the command can be adjusted using the **MEXE02** or **OPX-2A**.

The items that can be adjusted vary between the normal mode and the current control mode.

Item	Description	Normal mode	Current control mode
Operating current	Adjust the current during operation.	○	○
Standstill current	Adjust the current at standstill.	○	×
Speed filter	Apply a filter to input pulses to make the pulses smooth.	○	○
Smooth drive	Insert interpolation pulses between input pulses.	○	○
Speed error gain	Suppress vibration while the motor is accelerating/decelerating.	○	×
Position loop gain Speed loop gain Speed integral time constant	Vibration that generates while the motor is accelerating/decelerating or at standstill can be adjusted to an optimal level.	×	○
Anti-vibration control	Enclosure vibration that occurs with an equipment of low rigidity can be adjusted to an optimal level.	×	○

5-1 Control mode

The driver operates in one of two control modes: the normal mode, and the current control mode. The desired mode can be set using the Dip SW-No.2. If noise is heard during high-speed operation or there is notable vibration, it may be effective to switch to the current control mode.

Note, however, that a slight delay may occur in the current control mode, compared to the normal mode, depending on the condition of the load. Keep the driver in the normal mode during normal conditions of use.

Dip SW-No.2 is set to the left side (OFF): Normal mode

Dip SW-No.2 is set to the right side (ON): Current control mode

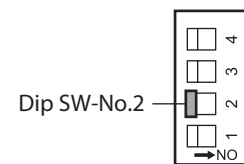

- memo**
- The new setting of the Dip SW will be enabled after the power is cycled. If a 24 VDC power supply is used with the AC power input type, also cycle the 24 VDC power supply.
 - In the normal mode, the CCM input is enabled.

5-2 Operating current

Set a desired operating current using the CURRENT switch.

The operating current to be set is the maximum output current multiplied by the operating current rate (%) set to each dial setting of the CURRENT switch, where "F" corresponds to 100%.

One of 16 operating current levels from 0 to F can be set. If the load is small and there is an ample allowance for torque, you can suppress rise in motor temperature by setting a lower operating current.

You can change the value assigned to each dial setting of the CURRENT switch, by using a corresponding parameter.



- Note**
- If the operating current is too low, starting of the motor and its position hold function may be affected. Do not lower the operating current more than necessary.

Related parameter

MEXE02 tree view	Parameter name	Description	Initial value
Operation current	Operating current setting 0	Sets each operating current rate assigned to the CURRENT switch. [Setting range] 0.0 to 100.0%	6.3
	Operating current setting 1		12.5
	Operating current setting 2		18.8
	Operating current setting 3		25.0
	Operating current setting 4		31.3
	Operating current setting 5		37.5
	Operating current setting 6		43.8
	Operating current setting 7		50.0
	Operating current setting 8		56.3
	Operating current setting 9		62.5
	Operating current setting A		68.8
	Operating current setting B		75.0
	Operating current setting C		81.3
	Operating current setting D		87.5
	Operating current setting E		93.8
	Operating current setting F		100.0

5-3 Standstill current

When the motor stops, the current cutback function will be actuated to lower the motor current to the standstill current.

The standstill current is a value that the operating current which was set with the CURRENT switch is multiplied by a value of the standstill current.

Related parameter

MEXE02 tree view	Parameter name	Description	Initial value
Normal mode	Standstill current	Sets the standstill current as a percentage of the operating current. [Setting range] 0.0 to 50.0%	50.0

Note The current cutback function does not operate while the push-motion operation mode is performed (when the T-MODE input is being ON). Even if the operation is stopped, the current does not drop and it keeps the push current.

5-4 Speed filter

You can use the V-FIL switch to adjust how the motor responds to input pulses.

One of 16 speed filter levels from 0 to F can be set.

When the speed filter level is raised, vibration can be suppressed during low-speed operation, and starting/stopping of the motor will become smooth. Note, however, that an excessively high filter level will result in lower synchronicity with commands. Set an appropriate value according to the specific load and purpose. You can change the value assigned to each dial setting of the V-FIL switch, by using a corresponding parameter.



Related parameter

MEXE02 tree view	Parameter name	Description	Initial value
Speed filter	Speed filter setting 0	Sets each filter time constant assigned to the V-FIL switch. [Setting range] 0 to 200 ms	0
	Speed filter setting 1		1
	Speed filter setting 2		2
	Speed filter setting 3		3
	Speed filter setting 4		5
	Speed filter setting 5		7
	Speed filter setting 6		10
	Speed filter setting 7		20
	Speed filter setting 8		30
	Speed filter setting 9		50
	Speed filter setting A		70
	Speed filter setting B		100
	Speed filter setting C		120
	Speed filter setting D		150
	Speed filter setting E		170
	Speed filter setting F		200

5-5 Smooth drive

When the smooth drive function is used, the driver automatically implements microstep control over input pulses. This helps suppress motor vibration. If the smooth drive function is not used, vibration may increase in the low-speed range although starting characteristics will improve.

Related parameter

MEXE02 tree view	Parameter name	Description	Initial value
Operation	Smooth drive	Changes the setting to enable/disable the smooth drive. [Setting range] 0: Disable 1: Enable	1



When a system parameter is changed, the new parameter will be enabled after the power is cycled. If a 24 VDC power supply is used with the AC power input type, also cycle the 24 VDC power supply.

5-6 Speed error gain

The speed error gain is used to suppress vibration while the motor is operating or accelerating/decelerating.

Related parameter

MEXE02 tree view	Parameter name	Description	Initial value
Normal mode	Speed difference gain 1	Suppress vibration during operation. [Setting range] 0 to 500	45
	Speed difference gain 2	Suppress vibration during acceleration/ deceleration. [Setting range] 0 to 500	45



The initial values reflect results of adjustment. Do not change the initial values in normal conditions of use.

5-7 Position loop gain, speed loop gain, speed loop integral time constant

These items are enabled in the current control mode.

Vibration that occurs while the motor is accelerating/decelerating or at standstill can be adjusted to an optimal value. (The optimal value varies depending on the equipment and operating conditions.)

Related parameter

MEXE02 tree view	Parameter name	Description	Initial value
Operation current	Position loop gain	Adjusts the motor response in reaction to the position deviation. When this value is increased, the motor response will become quicker and motor overshoot will decrease. However, an excessively high value may cause motor hunting. [Setting range] 1 to 50	10
	Speed loop gain	Adjusts the motor response in reaction to the speed deviation. When this value is increased, the motor response will become quicker and motor overshoot will decrease. However, an excessively high value may cause motor hunting. [Setting range] 10 to 200	180
	Speed loop integral time constant	Decreases the deviation that cannot be adjusted with the speed loop gain. When this value is decreased, the motor response will become quicker and motor overshoot will decrease. However, an excessively high value may cause motor hunting. [Setting range] 10.0 to 200.0 ms	100.0

5-8 Anti-vibration control

This item is enabled in the current control mode.

Even when the motor is assembled into a machine of low rigidity, residual vibration can be suppressed during positioning, in order to shorten the positioning time. (The optimal value varies depending on the equipment and operating conditions.)

Related parameter

MEXE02 tree view	Parameter name	Description	Initial value
Operation current	Anti-vibration control	Changes the setting to enable/disable anti-vibration control. [Setting range] 0: Disable 1: Enable	0
	Frequency of anti-vibration control	Sets the frequency of anti-vibration control. [Setting range] 3.00 to 100.00 Hz	7.00

6 Operation using the OPX-2A

This chapter explains the overview and operating method for the **OPX-2A**.
When connect or disconnect the **OPX-2A** cable, turn off the driver power.

6-1 Overview of the OPX-2A

The **OPX-2A** is a data setter that lets you set parameters, perform monitoring, etc. In addition, the **OPX-2A** can be used to save the data of driver. There are four destinations (data banks) to save data.

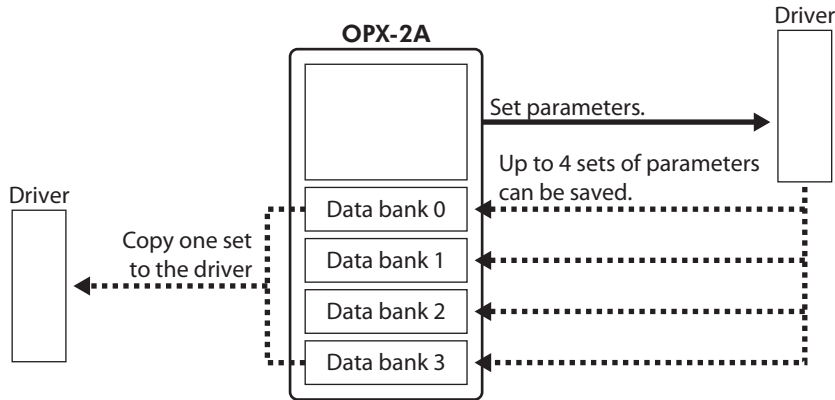

The **OPX-2A** can be used for the following purposes:

- Monitor the operating status of the motor.
- Check and clear the alarm records.
- Set parameters for the driver.
- The parameters set in the driver can be saved to the **OPX-2A**.
- The parameters saved in the **OPX-2A** can be copied to another driver connected to the **OPX-2A**.

■ Notation

In this manual, keys are denoted by symbols, such as $\left[\begin{smallmatrix} \text{MODE} \\ \text{ESC} \end{smallmatrix} \right]$ [SET] [↑] [↓] [←] [→].
In figures, a simplified illustration of the display and LED indicators is used, as shown below.



■ Edit lock function

Enable the edit lock function if you want to prevent parameters from being edited or cleared. Parameters cannot be changed or deleted while the edit lock function is enabled.

● Setting the edit lock function

In the top screen of each operation mode, press the $\left[\begin{smallmatrix} \text{MODE} \\ \text{ESC} \end{smallmatrix} \right]$ key for at least 5 seconds.

The display will show "Lock" and the edit lock function will be enabled.

The "LOCK" LED in the LED indicator area will also be lit.

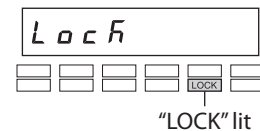

● Canceling the edit lock function

Again in the top screen of each operation mode, press the $\left[\begin{smallmatrix} \text{MODE} \\ \text{ESC} \end{smallmatrix} \right]$ key for at least 5 seconds.

The display will show "UnLock" and the edit lock function will be cancelled.

The "LOCK" LED in the LED indicator area will turn off.



6-2 Names and functions of parts

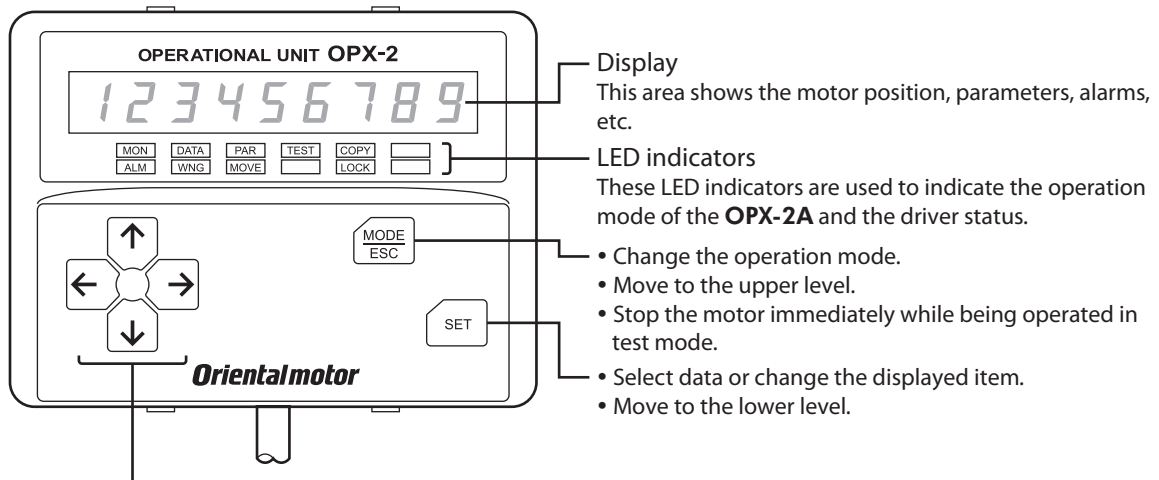

- Display**
This area shows the motor position, parameters, alarms, etc.
- LED indicators**
These LED indicators are used to indicate the operation mode of the **OPX-2A** and the driver status.
 - Change the operation mode.
 - Move to the upper level.
 - Stop the motor immediately while being operated in test mode.
 - Select data or change the displayed item.
 - Move to the lower level.

Use these buttons to change the selected item or set parameters.

- Increase or decrease the value.
- Change the selected item.
- Navigate through each parameter to a desired digit.

6-3 How to read the display

The display consists of 7-segment LEDs. (The number "5" and alphabet "S" are the same.)

• Numbers

1	1	2	3	4	5	6	7	8	9	0
---	---	---	---	---	---	---	---	---	---	---

• Alphabets

A	R	B	b	C	c	D	d	E	E	F	F	G	G	H	H	I	,	J	J	K	K	L	L
M	n̄	N	n	O	o	P	P	Q	q	R	r	S	S	T	t	U	U	V	v	W	w	Y	Y

• Signs

+	+	-	-
---	---	---	---

■ How to read the LED indicators

When the operation mode is changed or an alarm or warning generates, a corresponding LED will be lit. While the motor is operating or the edit lock function is enabled, the condition is also indicated by the illumination of a corresponding LED.

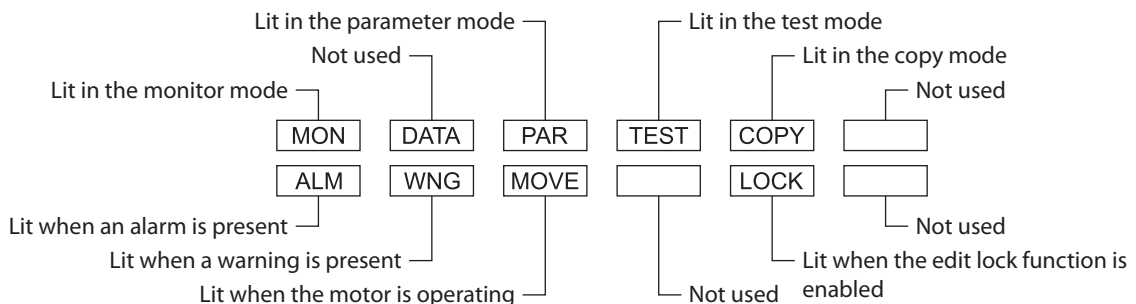

6-4 OPX-2A error display

Errors displayed on the **OPX-2A** are explained.

Error display	Meaning	Action
	A communication error occurred between the OPX-2A and driver.	<ul style="list-style-type: none"> • Check if the OPX-2A is connected securely. • Check if the OPX-2A cable is disconnected or damaged. • The OPX-2A or the communication part of the driver may have damaged. Contact your nearest Oriental Motor sales office.

6-5 Screen transitions



- The following limitations are present while the edit lock function is enabled.
 - Parameter mode, copy mode: Although they are displayed on the screen, they are unable to operate.
 - Clearing the alarm and warning records, reset the electrical home: They are not displayed on the screen.
- In the lower level except the top screen, press [MODE/ESC] to return to the previous level.

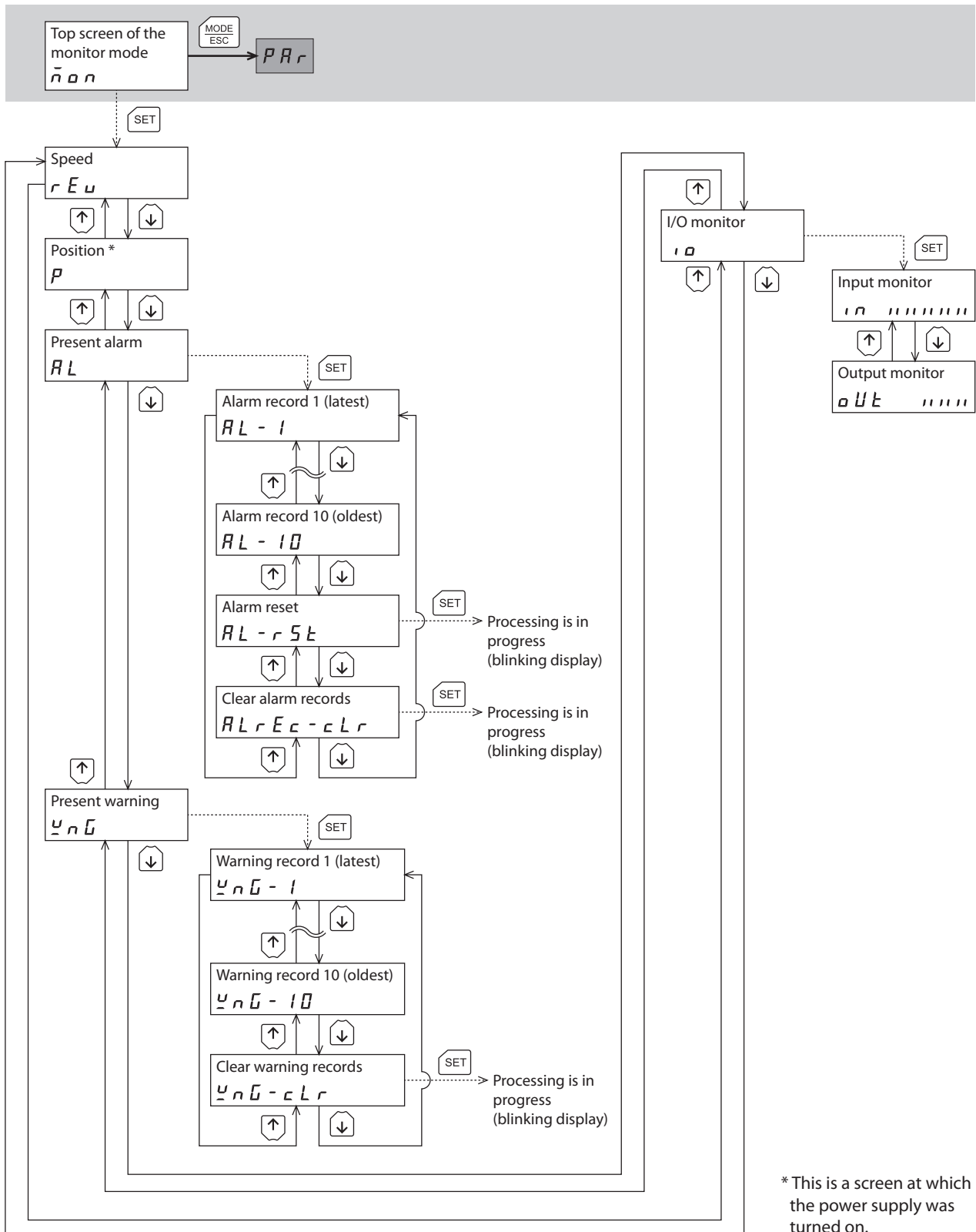

* This is a screen at which the power supply was turned on.

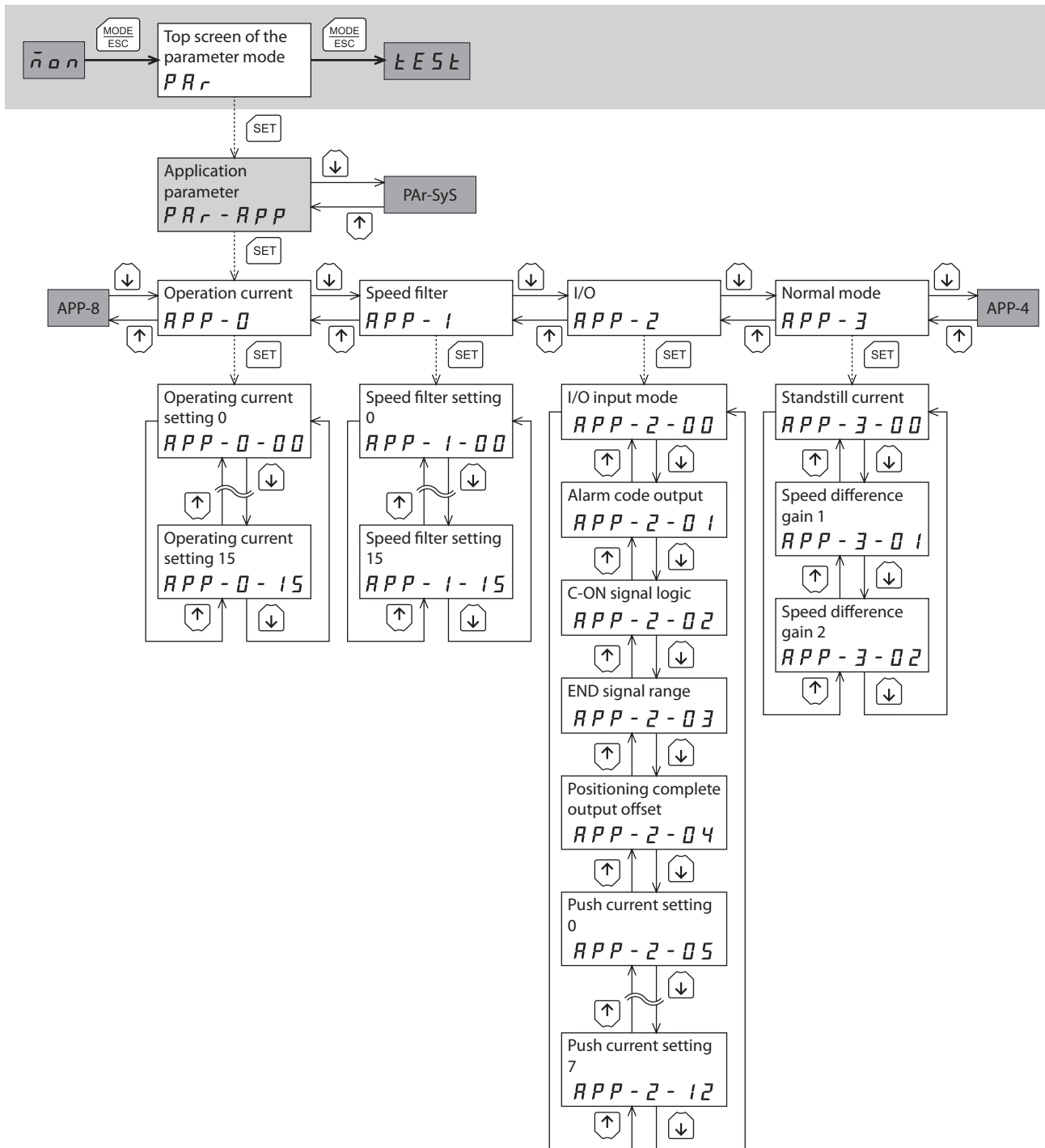

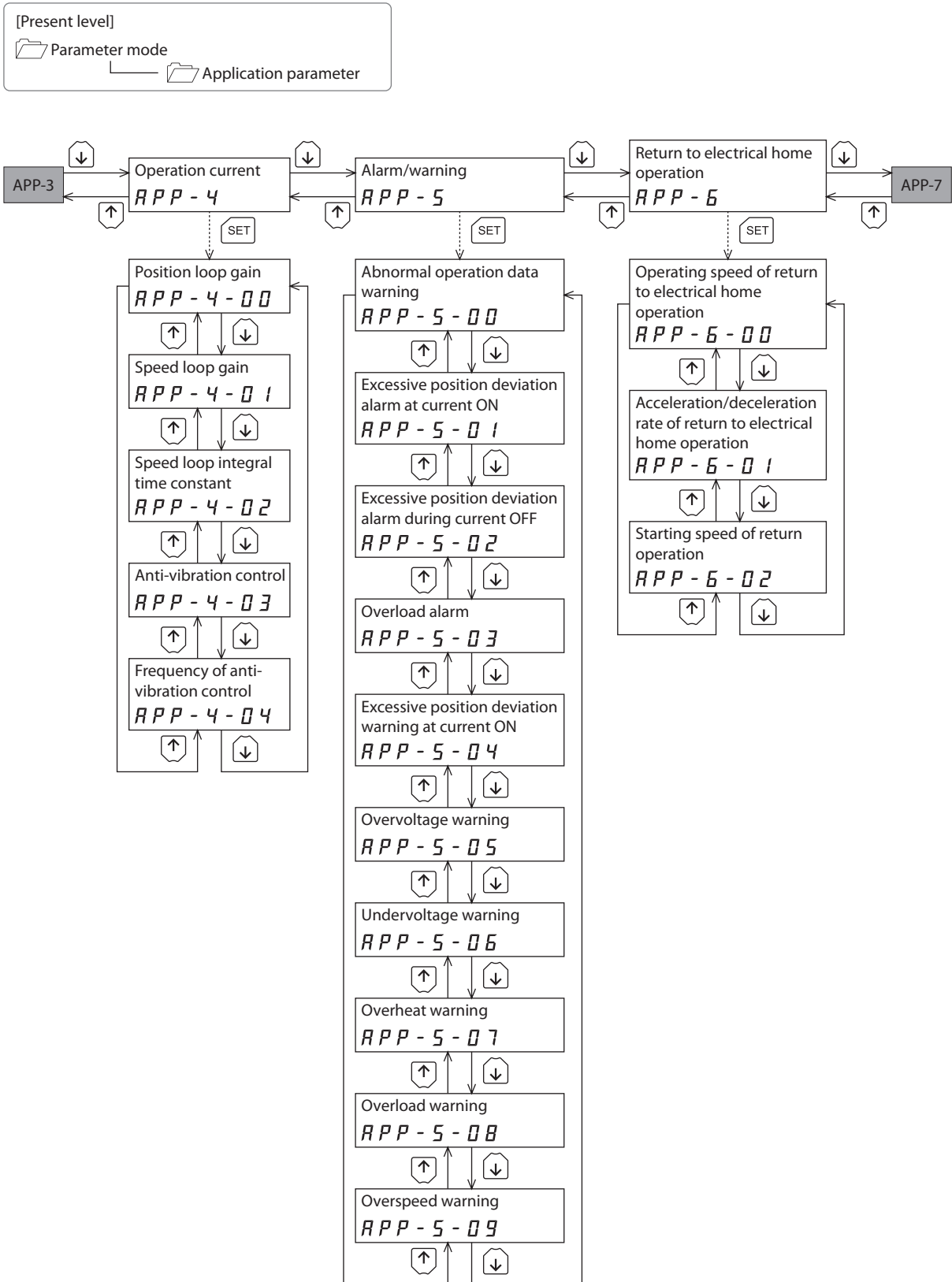

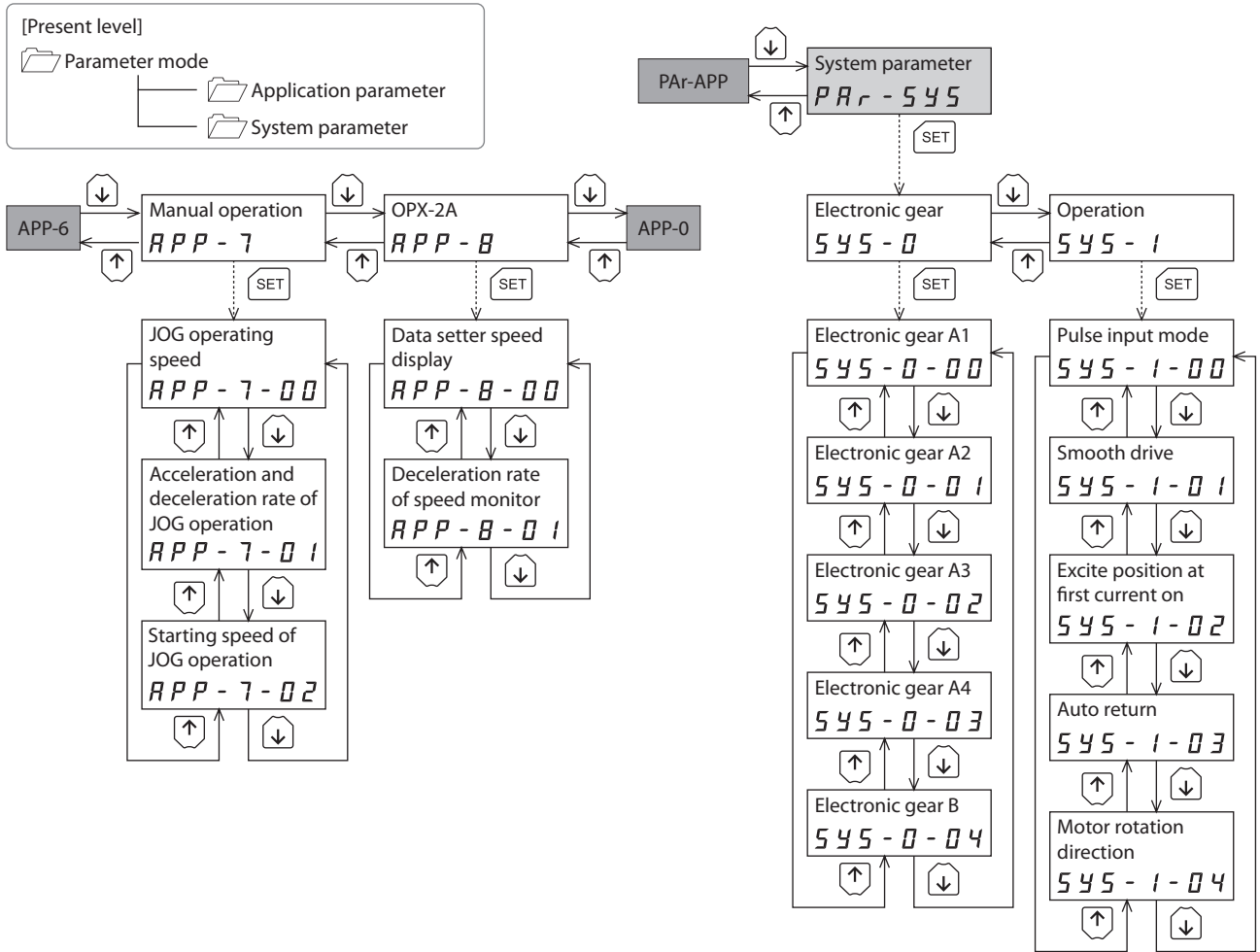

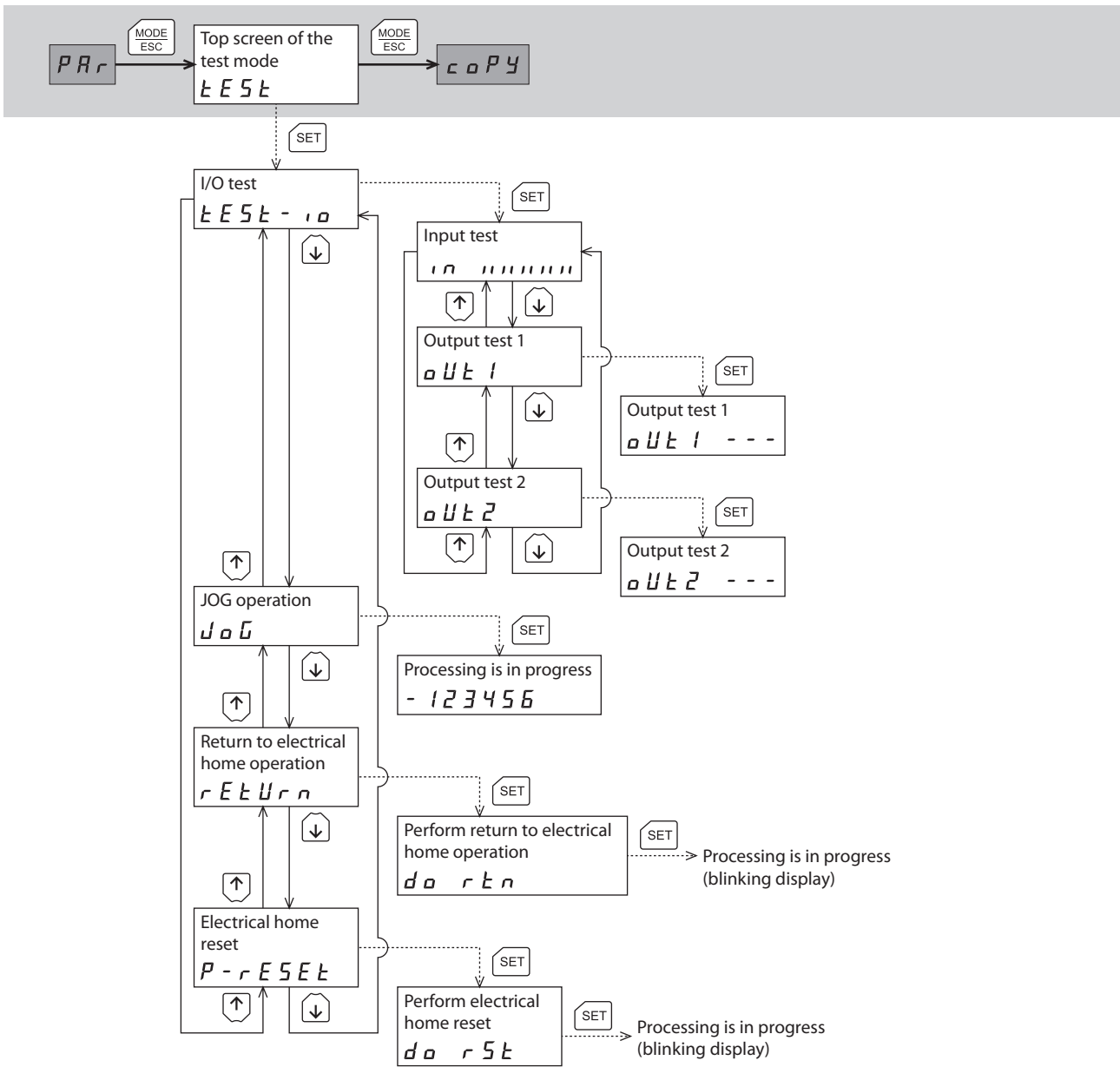

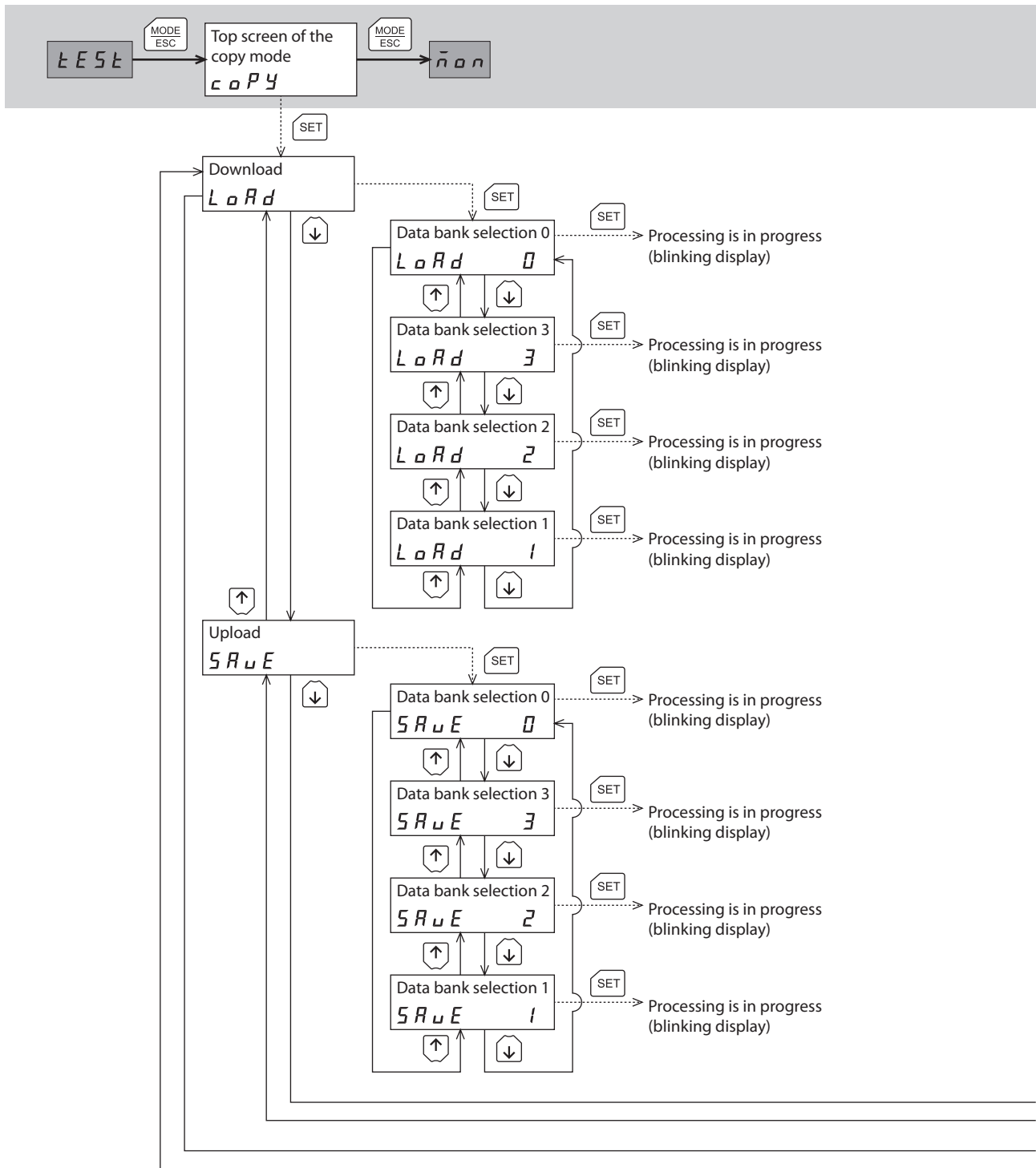

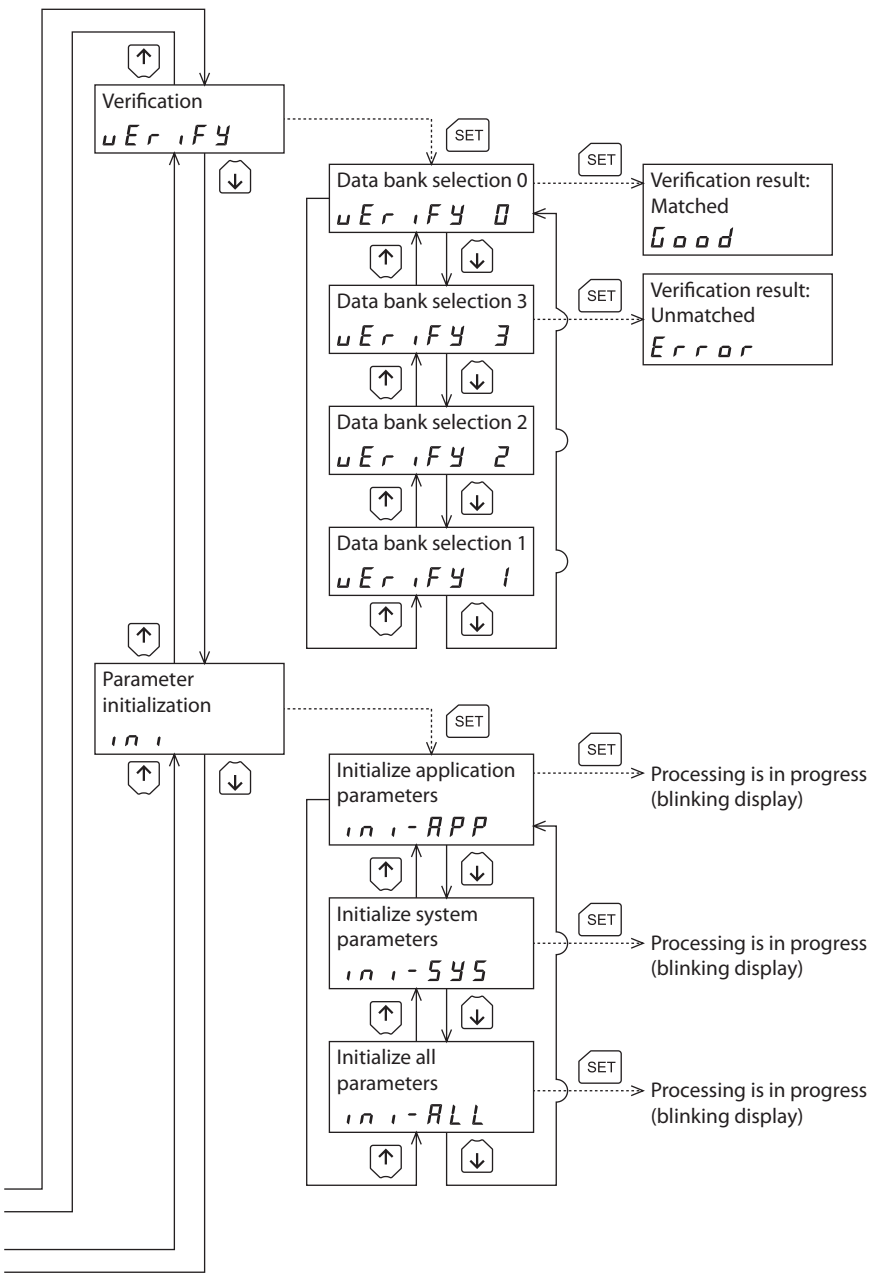

6-6 Monitor mode

■ Overview of the monitor mode

● Monitoring the operating status

You can monitor the motor speed and position in real time.

memo A range capable to monitor with the **OPX-2A** is from -19,999,999 to 19,999,999 with up to eight digit numbers. However, only seven digit numbers can be shown on the display of the **OPX-2A**, so only the last seven digit numbers are shown when the monitored value is eight digit numbers, and a dot is marked on the lower right of the display.

- Display example

Actual value	-19,999,999	-10,000,001	-10,000,000	10,000,000	10,000,001	19,999,999
Displayed value	-9999999.	-0000001.	-0000000.	0000000.	0000001.	9999999.

● Checking the alarms/warnings, clearing alarm/warning records, and resetting alarms

- If an alarm or warning generates, a corresponding alarm code or warning code will be displayed. You can check the code to identify the details of the alarm/warning.
- Up to ten most recent alarms/warnings can be displayed, starting from the latest one.
- You can reset the alarms currently present.
- You can clear alarm/warning records.

● Checking the I/O signals

You can check the ON/OFF status of each I/O signal of the driver.

■ Monitor items

● Speed

You can check the motor speed (unit: r/min).

While the motor is rotating in the CCW direction, “-” is shown in front of the displayed value. If the speed is indicated by an absolute value, no sign is shown to indicate the rotating direction. You can select the value display format using the application parameter for data setter speed display.

You can also display the motor speed as revolutions of the gear output shaft. For this setting, use the application parameter for deceleration rate of speed monitor.

● Position

You can check the current position of the motor with reference to the home position.

If a resolution is set, an appropriate value based on the resolution is shown as steps.

● Present alarm

When an alarm generates, a corresponding alarm code will be displayed. You can also reset alarms or check and clear alarm records. Refer to p.142 for details about alarm codes and the method to reset alarms.

Note Do not turn off the driver power while an alarm is being reset or alarm records are being cleared (=while the display is blinking). Doing so may damage the data.

● Present warning

When a warning generates, a corresponding warning code will be displayed. You can also check or clear warning records. For details about warning code, refer to p.146.

Note Do not turn off the driver power while warning records are being cleared (=while the display is blinking). Doing so may damage the data.

memo You can also clear the warning records by turning off the driver power.

● I/O monitor

You can check the ON/OFF status of each I/O signal of the driver.

Each digit on the 7-segment LED display corresponds to a signal. The LED is lit when the signal is ON, and it is unlit when the signal is OFF.

• Input signals

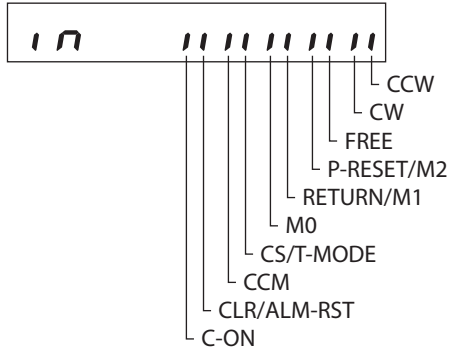

• Output signals

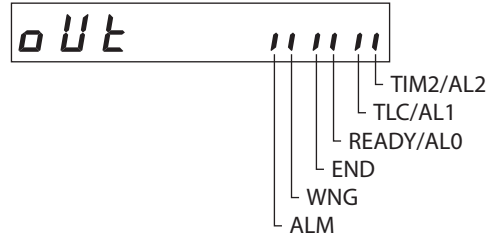

6-7 Parameter mode

You can set parameters relating to motor operation and control. These parameters are saved in the non-volatile memory of the driver.

■ Parameter type

There are application parameters and system parameters in the parameter mode. For details on parameter, refer to p.104.

● Application parameters

The application parameters is enabled when the setting was changed.

● System parameters

The system parameters will be enabled when the power supply was turned on again after the setting was changed. If a 24 VDC power supply is used with the AC power input type, also cycle the 24 VDC power supply.

■ Setting example

Pressing **[SET]** key on the parameter selection screen enables to set parameters. The setting method of the parameter is explained here.

Example: Set operating current setting 0 to "50"

1. Use the **[MODE/ESC]** key to select the parameter mode. The "PAR" LED is lit.
2. Press the **[SET]** key. The display changes to the application parameters screen.
3. Press the **[SET]** key. The display changes to the "operation current" parameter screen.
4. Press the **[SET]** key. The display to set the "operating current setting 0" appears.
5. Press the **[SET]** key. Use the **[↑][↓][←][→]** keys to input "050.0".
6. Press the **[SET]** key again. The input value is set, and the display returns to the "operating current 0 setting" parameter screen.

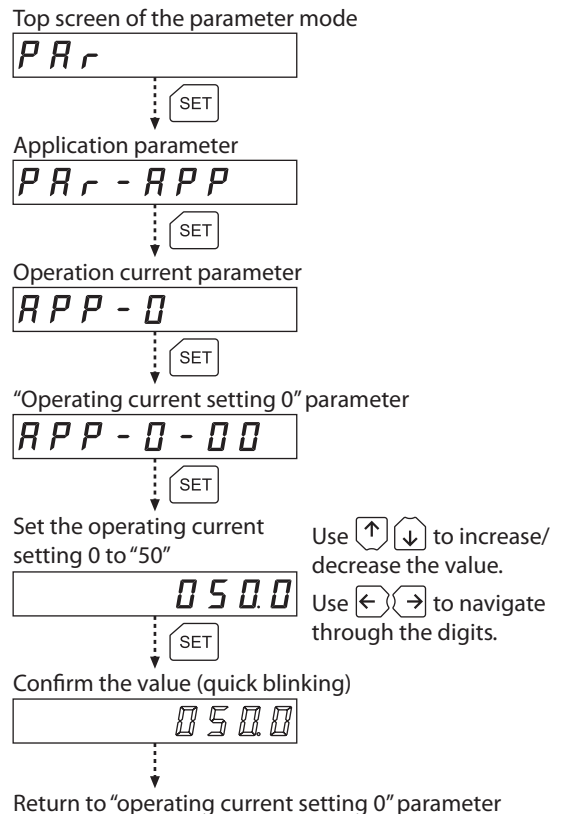

4 AC power input type/DC power input type Common



If the value you have input is outside the setting range, "Error" will be displayed for 1 second. If this error display appears, input a different value that falls within the setting range.

6-8 Test mode

Overview of the test mode

I/O test

You can check the ON/OFF status of each I/O signal of the driver. You can also switch the ON/OFF status of each output signal on the **OPX-2A**. When checking the connection condition of the driver, perform the I/O test.

JOG operation

You can operate the motor using the keys on the **OPX-2A**.

Return to electrical home operation

You can perform an operation that returns the motor to its electrical home position.

Electrical home reset

You can set the current position as the electrical home position.

What happens when the [SET] key is pressed while the motor is operating

While the motor is operating, you cannot move to any lower level from the top screen of the test mode. Pressing the [SET] key will generate an error, and "oPE-Err" will be shown. Be sure to stop the motor operation before pressing the [SET] key.

oPE-Err



- Stop the motor operation before changing to the test mode.
- When you move from the top screen of the test mode to a lower level, the CW/CCW inputs and RETURN input will be disabled.
- When you move from the I/O test or electrical home reset screen to a lower level, all I/O signals and operations will be disabled.

I/O test

When checking the connection condition of the driver, perform the I/O test.

Each digit on the 7-segment LED display corresponds to a signal.

The LED is lit when the input signal is ON, and it is unlit when the input signal is OFF.

Use the [↑][↓] keys to switch the ON-OFF state of the output signal. "0" is displayed when the signal is ON, while "-" is displayed when the signal is OFF.

Input signals

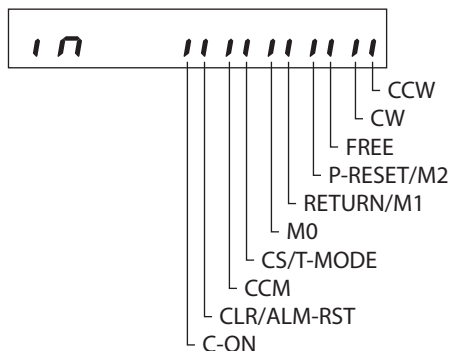

Output signals

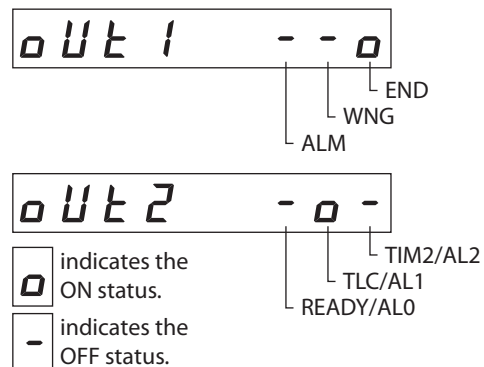

■ JOG operation

You can operate the motor using the keys on the **OPX-2A**.

Pressing the [↑] key once causes the motor to rotate one step in the positive direction. Pressing and holding the key causes the motor to rotate continuously in the positive direction.

Pressing the [↓] key once causes the motor to rotate one step in the negative direction. Pressing and holding the key causes the motor to rotate continuously in the negative direction.

The operating speed corresponds to the value set in the "JOG operating speed" parameter.

Take note that when the value set in the "starting speed of JOG operation" parameter is greater than the value set in the "JOG operating speed" parameter, the JOG starting speed will be enabled.

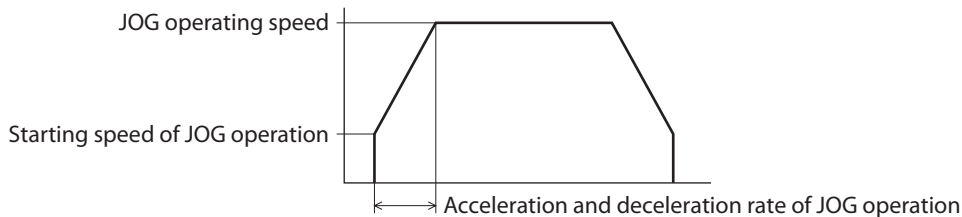

Note During operation, the motor rotates at the specified operating speed while each applicable key is pressed. Before commencing the operation, consider the status of the equipment and condition of its surroundings to confirm thoroughly that motor rotation will not cause any dangerous situations.

■ Return to electrical home operation

You can perform an operation that returns the motor to its electrical home position.

Note During operation, the motor rotates at the specified operating speed. Before commencing the operation, consider the status of the equipment and condition of its surroundings to confirm thoroughly that motor rotation will not cause any dangerous situations.

■ Electrical home reset

You can set the current position as the electrical home position.

memo If operations are limited by the edit lock function, the electrical home position cannot be reset.

6-9 Copy mode

● Download

Parameters saved in the **OPX-2A** can be copied to the driver. If a download error occurs, a code indicating the description of the error will blink on the display. Download will not be performed and the display will return to the top screen of download.

Refer to the following "Error of the copy mode" to display the error.

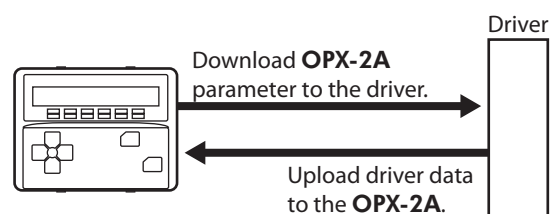

● Upload

Parameters saved in the driver can be copied to the **OPX-2A**.

● Verification

Parameters in the **OPX-2A** can be verified against the corresponding parameters in the driver.

If the verification finds that the two sets of parameter match, "Good" will be shown. If the two do not match, "Error" will be shown.

If a verification error occurs, a code indicating the description of the error will blink on the display. Verification will not be performed and the display will return to the top screen of verification.

Refer to the following "Error of the copy mode" to display the error.

● Initializing parameters

Parameters saved in the driver can be restored to the initial values.

■ **What happens when the [SET] key is pressed while the edit lock function is enabled**

While the edit lock function is enabled, you cannot move to any lower level from the top screen of the copy mode. Pressing the [SET] key will generate an error, and “Lock-Err” will be shown. Be sure to cancel the edit lock function before pressing the [SET] key. Refer to p.126 for the procedure to cancel the edit lock function.

L o c k - E r r

■ **Error of the copy mode**

If an error occurs in download or verification, the error code will blink on the display. At this time, the processing will not be executed and the display will return to the top screen.

Blinking display	Description	Action
<i>P r o d - E r r</i>	There is a discrepancy between the selected product series and the data being processed.	<ul style="list-style-type: none"> • Check the product series. • Check the data bank number on the OPX-2A.
<i>H E A d - E r r</i> <i>b c c - E r r</i>	An error occurred while processing.	Execute the processing again. If the same error occurs, the parameters saved in the OPX-2A may have damaged. Upload and set the parameters of the OPX-2A again.
<i>n o - d A t A</i>	The specified data bank number does not contain parameter.	Check the data bank number.
<i>d A t A - E r r</i>	An error occurred while writing parameter.	Execute the download again.

Note Do not turn off the driver power while processing is in progress (=while the display is blinking). Doing so may damage the parameter.

memo When a system parameter is changed, the new parameter will be enabled after the power is cycled. When system parameters were changed by downloading, cycle the driver power. If a 24 VDC power supply is used with the AC power input type, also cycle the 24 VDC power supply.

7 Inspection and maintenance

7-1 Inspection

It is recommended that periodic inspections be conducted for the items listed below after each operation of the motor. If an abnormal condition is noted, discontinue any use and contact your nearest office.

■ During inspection

- Check if any of the motor mounting screws come loose.
- Check if a bearing part (ball bearings) of the motor generates unusual noises.
- Check if the motor output shaft and the load shaft are out of alignment.
- Check if any of the motor cables have a scratch or receive a stress. Check if the connection part with the driver comes loose.
- Check if the openings in the driver are blocked.
- Check if the driver mounting screws or power connection terminal screws are loose.
- Check if any strange smells or appearances are within the driver.



The driver uses semiconductor elements. Handle the driver with care since static electricity may damage semiconductor elements.

7-2 Warranty

Check on the Oriental Motor Website or General Catalog for the product warranty.

7-3 Disposal

Dispose the product correctly in accordance with laws and regulations, or instructions of local governments.

8 Alarms and warnings

The driver provides alarms that are designed to protect the driver from overheating, poor connection, error in operation, etc. (protective functions), as well as warnings that are output before the corresponding alarms generate (warning functions).

8-1 Alarms

When an alarm generates, the ALM output will turn OFF and the motor will stop. (The motor will continue to operate after generating the abnormal operation data alarm, because abnormal operation data alarm does not cut off the motor current.)

When the application parameter for alarm code output is set to "enable", the READY output, TLC output and TIM2 output will automatically switch to the AL0 output, AL1 output and AL2 output, respectively.

Related parameter

MEXE02 tree view	Parameter name	Description	Initial value
I/O	Alarm code output	Output a corresponding alarm code using the READY/AL0 output, TLC/AL1 output and TIM2/AL2 output when an alarm generates. [Setting range] 0: Disable 1: Enable	0

When an alarm generates, the ALARM LED will blink. The present alarm can be checked by counting the number of times the ALARM LED blinks, or using the **MEXE02** or **OPX-2A**.

Example: Overvoltage alarm (number of blinks: 3)

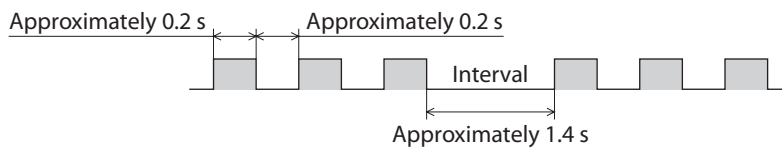

Alarm reset

Perform one of the reset operations specified below. Before resetting an alarm, always remove the cause of the alarm and ensure safety. Refer to p.156 for the timing chart.

- Turn the ALM-RST input to ON and then OFF. (The alarm will be reset at the OFF edge of the input.)
- Perform an alarm reset using the **MEXE02** or **OPX-2A**.
- Cycle the power.

memo Some alarms cannot be reset with the ALM-RST input, **MEXE02** or **OPX-2A**. Check the following table to identify which alarms meet this condition. To reset these alarms, you must cycle the power. If a 24 VDC power supply is used with the AC power input type, also cycle the 24 VDC power supply.

■ Descriptions of alarms

Alarm type	Number of ALARM LED blinks	Alarm code output	Alarm code	Motor operation *1	Alarm reset *2	Cause	Action
Overheat protection	2	AL2: OFF AL1: ON AL0: OFF	21	Non-excitation	Possible	The internal temperature of the driver exceeded 85 °C (185 °F).	Review the ventilation condition in the enclosure.
Overload			30	Non-excitation	Possible	The cumulative value of applied loads exceeding the peak torque reached or exceeded the value set in the overload alarm parameter.	<ul style="list-style-type: none"> Reduce the load or increase the acceleration/ deceleration rate. If the driver is in the current control mode, increase the value of the "Operating current setting" parameter. Check if the electromagnetic brake is released during operation.
Overspeed			31	Non-excitation	Possible	The speed of the motor output shaft exceeded 4500 r/min (excluding geared motors).	<ul style="list-style-type: none"> Check the electronic gear setting and reduce the speed of the motor output shaft to 4500 r/min or less. If the motor is overshooting at the time of acceleration, increase the acceleration/ deceleration rate.
Command pulse error			34	Non-excitation	Possible	The command pulse frequency exceeded the specified value.	<ul style="list-style-type: none"> Set the command pulse to 500 kHz or less. Check the electronic gear setting and reduce the speed of the motor output shaft to 4500 r/min or less.
Regeneration resistor overheat *3			51	Non-excitation	Not possible	<ul style="list-style-type: none"> The regeneration resistor is not connected correctly. The regeneration resistor is overheating. 	<ul style="list-style-type: none"> If no regeneration resistor is used, short the TH1 and TH2 terminals of CN1. Connect the regeneration resistor correctly. The regenerative power of the regeneration resistor exceeds the allowable level. Review the load condition and operating conditions.

Alarm type	Number of ALARM LED blinks	Alarm code output	Alarm code	Motor operation *1	Alarm reset *2	Cause	Action
Overvoltage protection	3	AL2: OFF AL1: ON AL0: ON	22	Non-excitation	Not possible	<ul style="list-style-type: none"> The power supply voltage exceeded the permissible value. A large inertial load was stopped abruptly. A vertical operation was performed. 	<ul style="list-style-type: none"> Check the main power supply voltage. If this alarm generates during operation, reduce the load or increase the acceleration/ deceleration rate. Connect the accessory regeneration resistor. *3
Main power supply error *3			23	Non-excitation	Possible	While the main power supply was being shut off in a state where the 24 VDC power supply was connected, the motor operation was started.	Check if the main power is input properly.
Undervoltage			25	Non-excitation	Possible	The main power was cut off momentarily or the voltage became low.	Check the input voltage of the main power supply.
Excessive position deviation during current on	4	AL2: ON AL1: OFF AL0: OFF	10	Non-excitation	Possible	<ul style="list-style-type: none"> When the current was turned on, the deviation between the command position and actual position at the motor output shaft exceeded the value set in the parameter for overflow rotation during current on. The load is large or acceleration/ deceleration rate is too short. 	<ul style="list-style-type: none"> Reduce the load, or increase the acceleration/ deceleration rate. If the driver is in the current control mode, increase the value of the "Operating current setting" parameter.
Excessive position deviation during current off			12	Non-excitation	Possible	The C-ON input was turned ON while an overflow rotation during current off warning was present.	<ul style="list-style-type: none"> Do not turn the C-ON input ON while an overflow rotation during current off warning is present. Set the auto return parameter to "disable."
Overcurrent protection *3	5	AL2: ON AL1: OFF AL0: ON	20	Non-excitation	Not possible	The motor, cable or driver output circuit was shorted.	Turn off the power and check the motor, cable and driver output circuit for shorting, and then cycle the power.
Drive circuit error *3			2D	Non-excitation	Not possible	The motor cable was disconnected.	Turn off the power and check the connection between the motor cable and driver, and then cycle the power.

4 AC power input type/DC power input type Common

Alarm type	Number of ALARM LED blinks	Alarm code output	Alarm code	Motor operation *1	Alarm reset *2	Cause	Action
Abnormal operation data	7	AL2: ON AL1: ON AL0: ON	70	Excitation	Possible	Return to electrical home operation was performed while an abnormal operation data warning was present.	Do not perform return to electrical home operation while an abnormal operation data warning is present.
Electronic gear setting error			71	Non-excitation	Not possible	The power was turned on when the resolution set by the electronic gear was outside the specified range.	Turn on the power again after setting the "electronic gear" parameter correctly so that the resolution is in a range of "100 to 10000 P/R."
Sensor error during operation	8	AL2: OFF AL1: OFF AL0: OFF	28	Non-excitation	Not possible	A sensor error occurred while the motor was operating.	Turn off the power and check the connection between the motor cable and driver, and then cycle the power.
Initial sensor error			42	Non-excitation	Not possible	A sensor error occurred when the power was turned on.	Turn off the power and check the connection between the motor cable and driver, and then cycle the power.
Initial rotor rotation error			43	Non-excitation	Not possible	The motor output shaft rotated at a speed of 15 r/min or more while the initialization was still in progress following a power on.	Adjust the load and make sure the motor output shaft does not turn due to an external force when the power is turned on.
Motor combination error			45	Non-excitation	Not possible	A motor not supported by the driver is connected.	Check the driver model and motor model, and use the driver and motor in the correct combination.
EEPROM error	9	AL2: OFF AL1: OFF AL0: ON	41	Non-excitation	Not possible	Data stored in the driver was damaged.	Initialize the parameters using the MEXE02 or OPX-2A .

*1 When an alarm generates, the motor excitation operation is as follows.

Non-excitation: When an alarm generates, the motor current will be cut off and the motor will lose its holding torque. In the case of an electromagnetic brake motor, the motor will become unexcited and the electromagnetic brake will hold the load automatically.

Excitation: Even when an alarm generates, the motor current will not be cut off and the motor position will be held.

*2 Reset using the ALM-RST input/**MEXE02**/**OPX-2A**.

*3 AC power input only.

If the alarm is not cleared even when these remedial actions have been performed, the driver may have been damaged. Contact your nearest Oriental Motor sales office.

8-2 Warnings

When a warning generates, the WNG output will turn ON. The motor will continue to operate.

Once the cause of the warning is removed, the WNG output will turn OFF automatically.

Present warnings can be checked using the **MEXE02** or **OPX-2A**.

You can also check the records of up to ten most recent warnings starting from the latest one, or clear the warning records.



You can also clear the warning records by turning off the driver power.

■ Descriptions of warnings

Warning type	Warning code	Cause	Action
Excessive position deviation during current on	10	<ul style="list-style-type: none"> When the current was turned on, the deviation between the command position and actual position at the motor output shaft exceeded the value set in the parameter for excessive position deviation during current on. The load is large or acceleration/ deceleration rate is too short. 	<ul style="list-style-type: none"> Reduce the load or increase the acceleration/deceleration rate. If a torque limit is set using the MEXE02 or OPX-2A, increase the setting.
Excessive position deviation during current off	12	When the current was turned off, the deviation between the command position and actual position to motor output shaft exceeded the value set in the parameter for excessive position deviation during current off. (This warning is output when the parameter for auto return is set to "enable.")	<ul style="list-style-type: none"> Reduce the amount of rotation at current off to the specified setting or less. Or, change the setting. Turn the CLR input ON to clear the position deviation.
Overheat	21	The internal temperature of the driver exceeded the value set in the overheat warning parameter.	Review the ventilation condition in the enclosure.
Overvoltage	22	<ul style="list-style-type: none"> The voltage of the main power supply exceeded the value set in the overvoltage warning parameter. A large inertial load was stopped abruptly. A vertical operation was performed. 	<ul style="list-style-type: none"> Check the main power supply voltage. If this alarm generates during operation, reduce the load or increase the acceleration/deceleration rate. Connect the accessory regeneration resistor. *
Main power supply error *	23	The C-ON input was turned ON when the main power was cut off.	<ul style="list-style-type: none"> Do not turn the C-ON input ON while the main power is cut off. Check the C-ON input logic.
Undervoltage	25	<ul style="list-style-type: none"> The voltage of main power supply became lower than the value set in the undervoltage warning parameter. The main power was cut off momentarily or the voltage became low. 	Check the main power supply voltage.
Overload	30	<ul style="list-style-type: none"> A load exceeding the peak torque was applied for the time set in the overload warning parameter. The load is large or acceleration/ deceleration rate is too short. 	<ul style="list-style-type: none"> Reduce the load or increase the acceleration/deceleration rate. If the driver is in the current control mode, increase the value of the "Operating current setting" parameter. Check if the electromagnetic brake is released during operation.

Warning type	Warning code	Cause	Action
Overspeed	31	The detected motor speed exceeded the value set in the overspeed warning parameter.	<ul style="list-style-type: none"> • Check the electronic gear setting and reduce the speed of the motor output shaft to the value set in the parameter or less. • If the motor is overshooting at the time of acceleration, increase the acceleration/ deceleration rate.
Abnormal operation data	70	The CS input was changed when the current was on.	Do not change the CS input when the current is on.
		The traveled distance from the electrical home exceeded the control range (2,147,483,648 pulses). (This alarm generates when the application parameter for abnormal operation data warning is set to "enable.")	Turn the P-RESET input ON and set the electrical home, again.
Electronic gear setting error	71	The resolution set by the electronic gear is outside the specified range.	Set the parameter for electronic gear correctly so that the resolution is in a range of 100 to 10000 P/R.

* AC power input only.

9 Troubleshooting and remedial actions

During motor operation, the motor or driver may fail to function properly due to an improper setting or wiring. When the motor cannot be operated correctly, refer to the contents provided in this section and take appropriate action. If the problem persists, contact your nearest Oriental Motor sales office.

Phenomenon	Possible cause	Remedial action
<ul style="list-style-type: none"> The motor is not excited. The motor can be moved by hand. 	The C-ON input is turned OFF.	<ul style="list-style-type: none"> Turn the C-ON input ON and confirm that the motor will be excited. Check the setting of the application parameter for C-ON input logic.
	The FREE input is turned ON.	Turn the FREE input OFF.
There is holding torque even if motor excitation is turned OFF. *	Effect of dynamic brake.	If motor excitation is turned OFF by the C-ON input or STOP input, the motor coil will be short-circuited inside the driver, and the holding torque will be generated larger than when the power is shut off (dynamic brake). To release the dynamic brake, shut off the power or turn the FREE input ON.
The motor does not operate.	The CLR input is turned ON.	Turn the CLR input OFF.
	The CW input or CCW input is not connected properly.	<ul style="list-style-type: none"> Check the connection between the controller and driver. Check the pulse signal specifications (voltage, width).
	The CW input and CCW input are turned ON simultaneously in the 2-pulse input mode.	Each pulse signal input should specify either the CW input or CCW input, but not both. Make sure the terminal not receiving the signal input remains OFF.
	The pulse signal is connected to DIR input in the 1-pulse input mode.	Connect the pulse signal to the PLS input.
	An electromagnetic brake motor is used and the electromagnetic brake is not released.	Check the connection between the electromagnetic brake and driver.
The motor rotates in the direction opposite to the specified direction.	The CW input and CCW input are connected in reverse in the 2-pulse input mode.	Connect CW pulse signals via the CW input, and connect CCW pulse signals via the CCW input.
	The DIR input is set in reverse in the 1-pulse input mode.	Turn the DIR input ON to cause the motor to rotate in CW direction, and turn the input OFF to cause the motor to rotate in CCW direction.
	The system parameter for motor rotation direction is set wrong.	Check the setting of the motor rotation direction parameter.
The gear output shaft rotates in the direction opposite to the motor.	A gear that rotates in the direction opposite to the motor shaft is used.	<ul style="list-style-type: none"> With TH geared motors, the gear rotates in the direction opposite to the motor when the gear ratio is 20 or 30. With Harmonic geared motors, the gear always rotates in the direction opposite to the motor.
Motor operation is unstable.	Pulse signals are not connected properly.	<ul style="list-style-type: none"> Check the connection between the controller and driver. Check the pulse signal specifications (voltage, width).
Notable vibration occurs.	The load is small.	Lower the current using the CURRENT switch. If the motor output torque is too large relative to the load, vibration will increase.
The electromagnetic brake does not hold the load.	The power is input to the electromagnetic brake.	Check the connection between the electromagnetic brake and driver.
	The FREE input is turned ON.	Turn the FREE input OFF.
The electromagnetic brake is not released.	The power is not supplied to the electromagnetic brake.	Check the connection between the electromagnetic brake and driver.
The TIM output does not turn ON.	The CS input was turned OFF while the motor was operating.	The TIM output may not turn ON if the CS input is switched from ON to OFF.

* DC power input only.



-
- When an alarm generates, check the alarm message.
 - I/O signals can be monitored using the **MEXE02** or **OPX-2A**. Use these accessories to check the wiring conditions of I/O signals.
-

4 AC power input type/DC power input type Common

5 Appendix

◆ Table of contents

1	Timing charts.....	152
2	Specifications	163
3	General specifications	164
	3-1 AC power input	164
	3-2 DC power input	165
4	Regulations and standards.....	166
	4-1 UL Standards	166
	4-2 EU Directives.....	166
	4-3 Republic of Korea, Radio Waves Act.....	167
	4-4 RoHS Directive	167



1 Timing charts

■ Power supply input

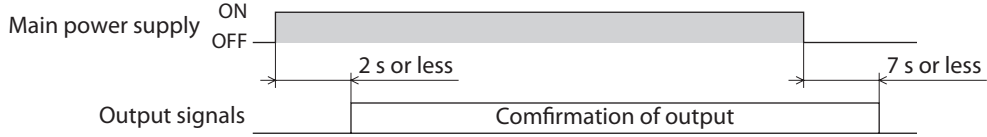

■ C-ON input (DC power input)

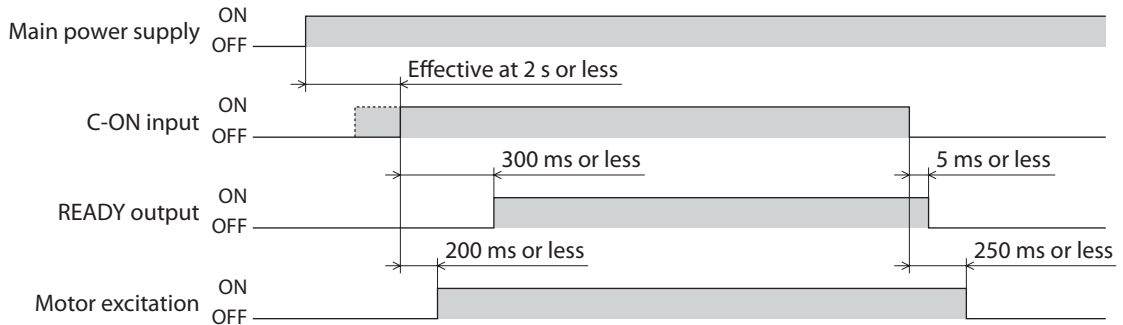

■ C-ON input (AC power input)

- The C-ON input is turned ON after turning on the power

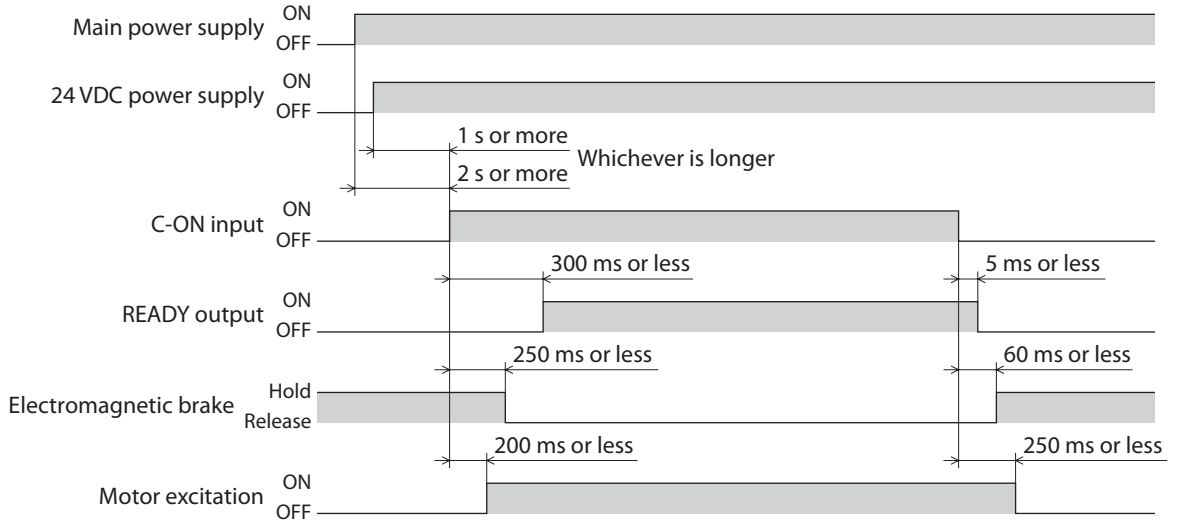

- If 24 VDC power is not input, the electromagnetic brake does not operate.
- When the C-ON input is OFF, motor excitation will turn off after the electromagnetic brake is actuated.

- The power is turned on after turning the C-ON input ON, or the main power is cut off.

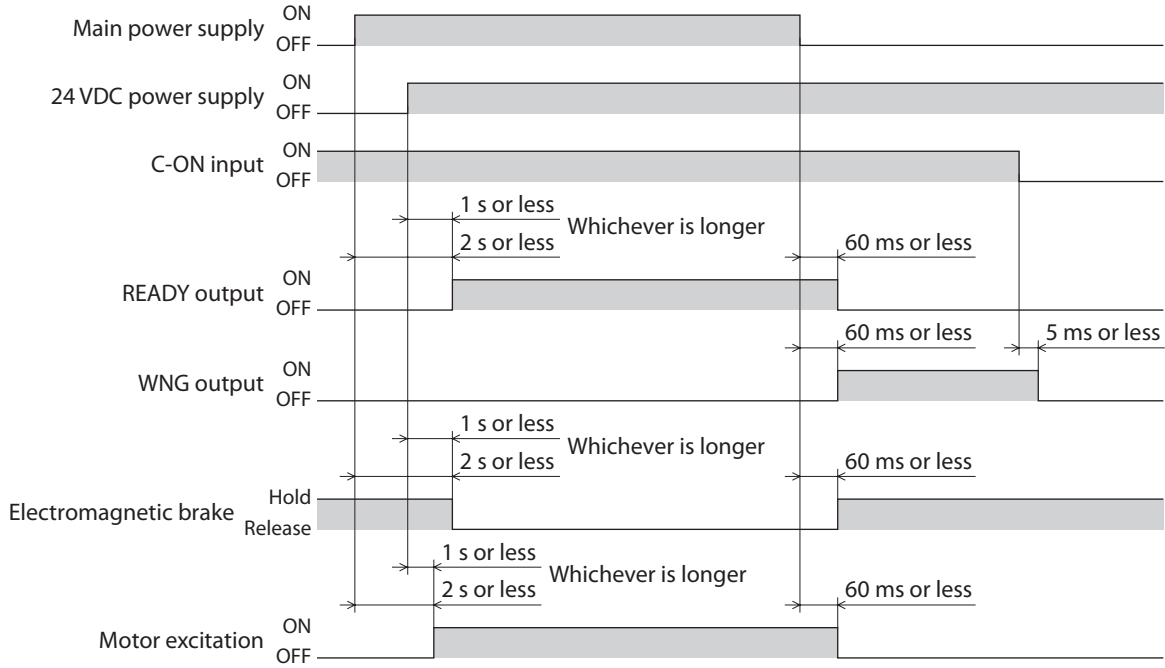

- If the main power is cut off, electromagnetic brake operation and motor excitation will turn off simultaneously.

■ FREE input (DC power input)

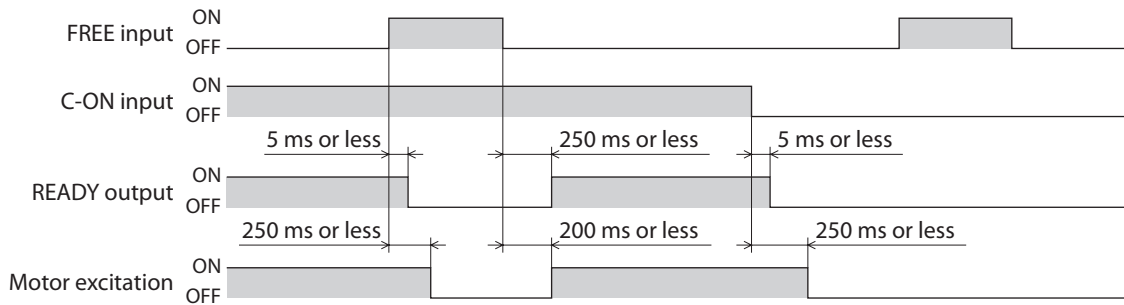

■ FREE input (AC power input)

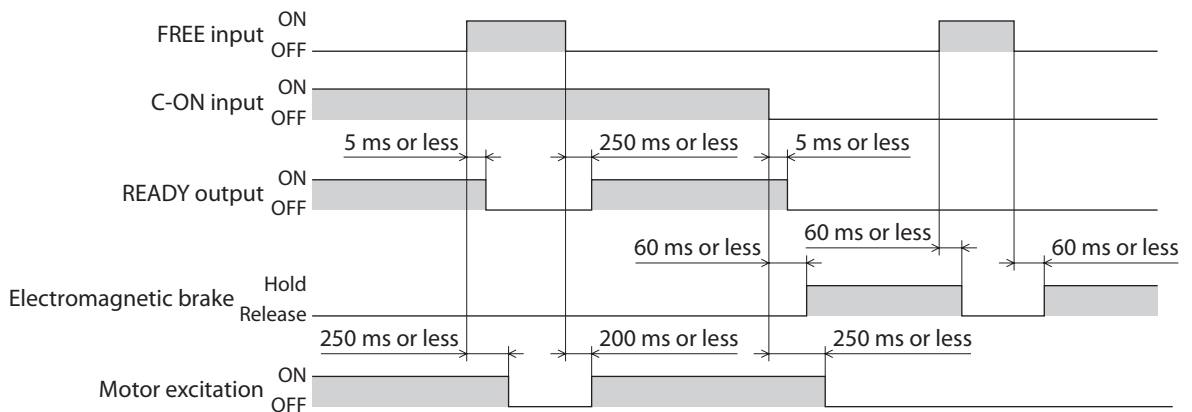

■ P-RESET input

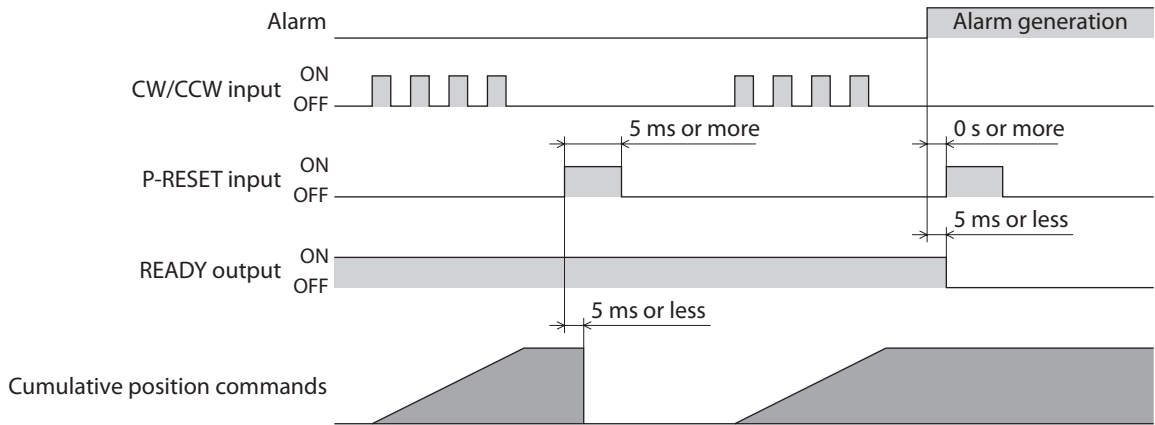

- When the P-RESET input is turned ON, the cumulative value of position commands will be reset to "0" and the current position will be set as the electrical home.
- If an alarm generates, the P-RESET input will become invalid.
- Input the P-RESET signal while the motor is at standstill.

■ CS input

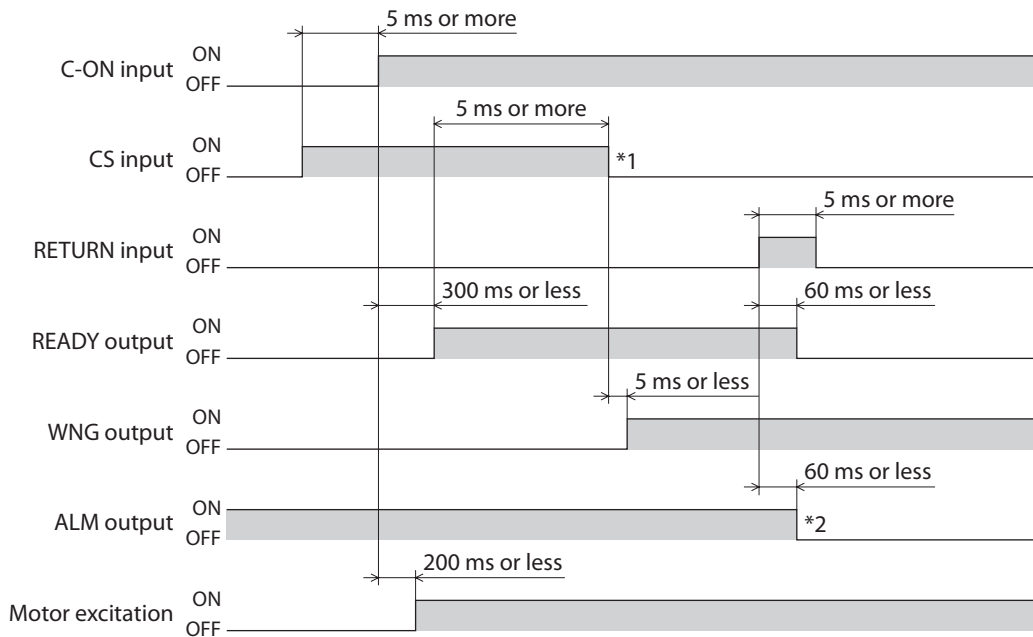

- *1 If the CS input is changed while the C-ON input is ON, an operation data error warning will generate.
- *2 If a return to electrical home operation is performed while an operation data error warning is present, an operation data error alarm will generate. Note that the motor will remain excited.
- This timing chart assumes that the application parameter for abnormal operation data warning is set to "enable."
- Change the CS input when the current is turned off.

■ T-MODE input, M0 to M2 inputs

The motor current waveform in the following chart assumes that the standstill current is set to 50% while the push current is set to 100%.

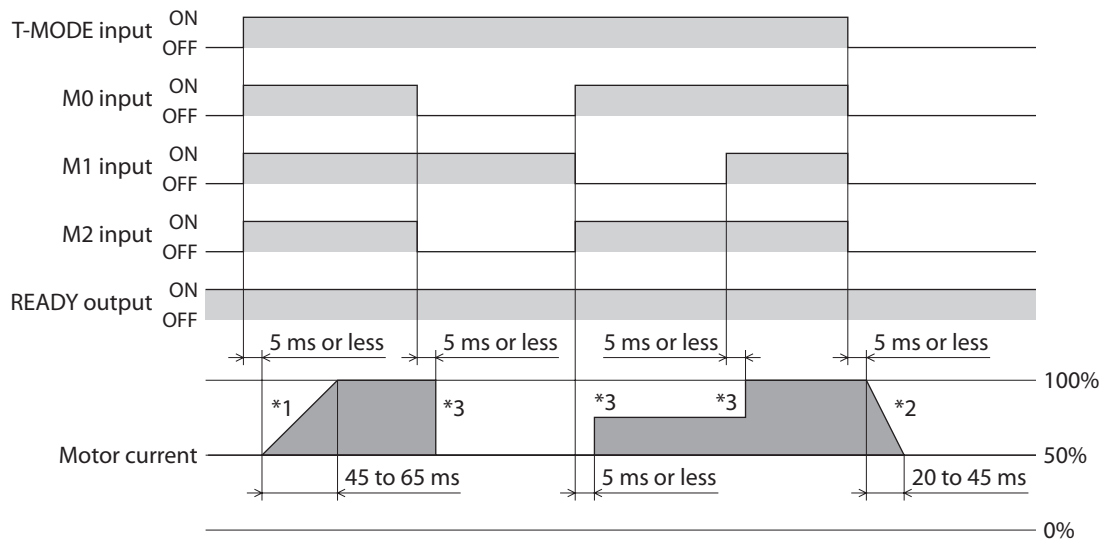

- *1 When the T-MODE is ON, the motor current rises to the push current at a rate of approximately 0.9% per millisecond.
- *2 When the T-MODE is OFF, the motor current drops to the push current at a rate of approximately 1.8% per millisecond.
- *3 When the value of push current is changed using the M0 to M2 inputs, the change is reflected immediately.
 - When the T-MODE input is turned ON, the value of push current set by the M0 to M2 inputs will be enabled, and the overload alarm will be disabled.
 - Input the T-MODE signal while the motor is at standstill.
 - The combinations of M0 to M2 inputs and corresponding initial values of push-current percentage are shown below. (Values are based on the rated current being 100%.)

M2	M1	M0	Initial value (%)
OFF	OFF	OFF	30.0
OFF	OFF	ON	40.0
OFF	ON	OFF	50.0
OFF	ON	ON	60.0
ON	OFF	OFF	70.0
ON	OFF	ON	80.0
ON	ON	OFF	90.0
ON	ON	ON	100.0

■ CLR input

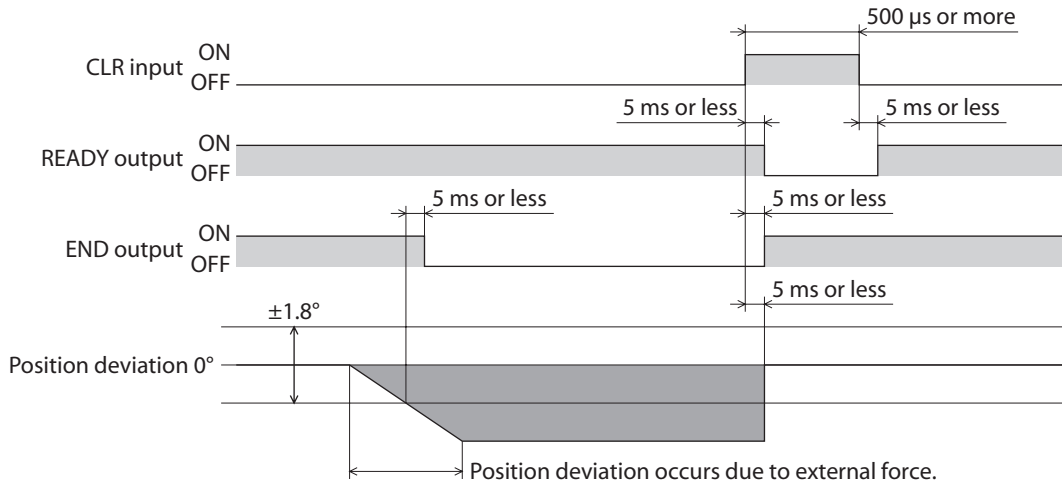

■ ALM-RST input (DC power input)

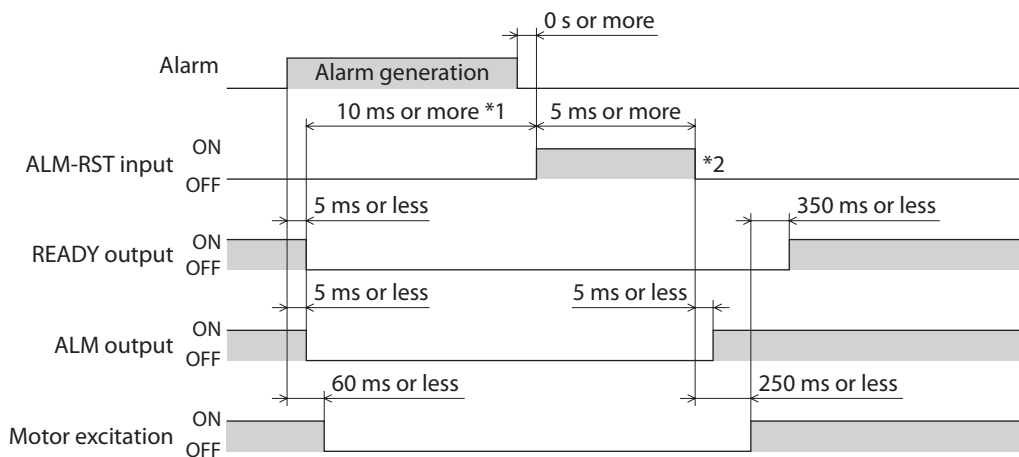

■ ALM-RST input (AC power input)

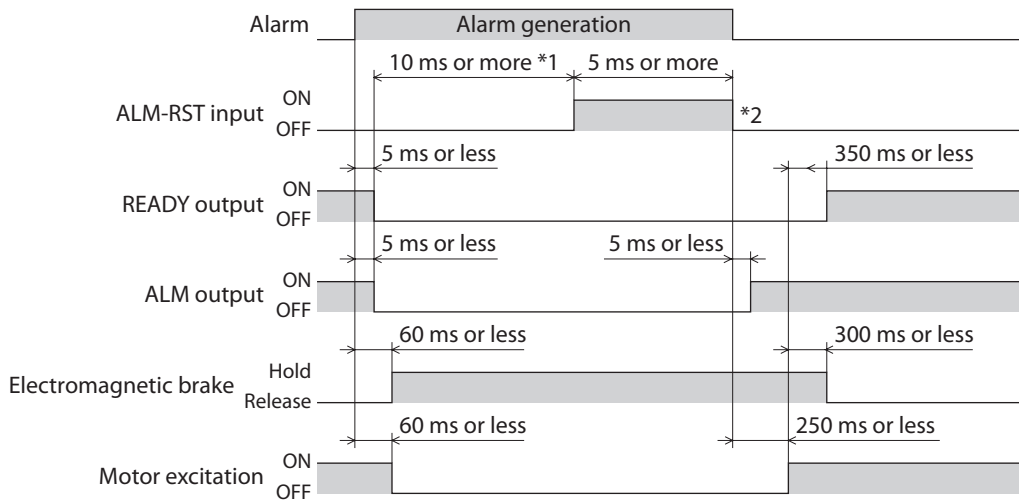

*1 The specific time varies depending on when an alarm record is saved.

*2 An alarm is reset at the OFF edge of the ALM-RST input.

- This timing chart assumes generation of an alarm that turns off motor excitation.

■ **TLC output**

● **Normal mode**

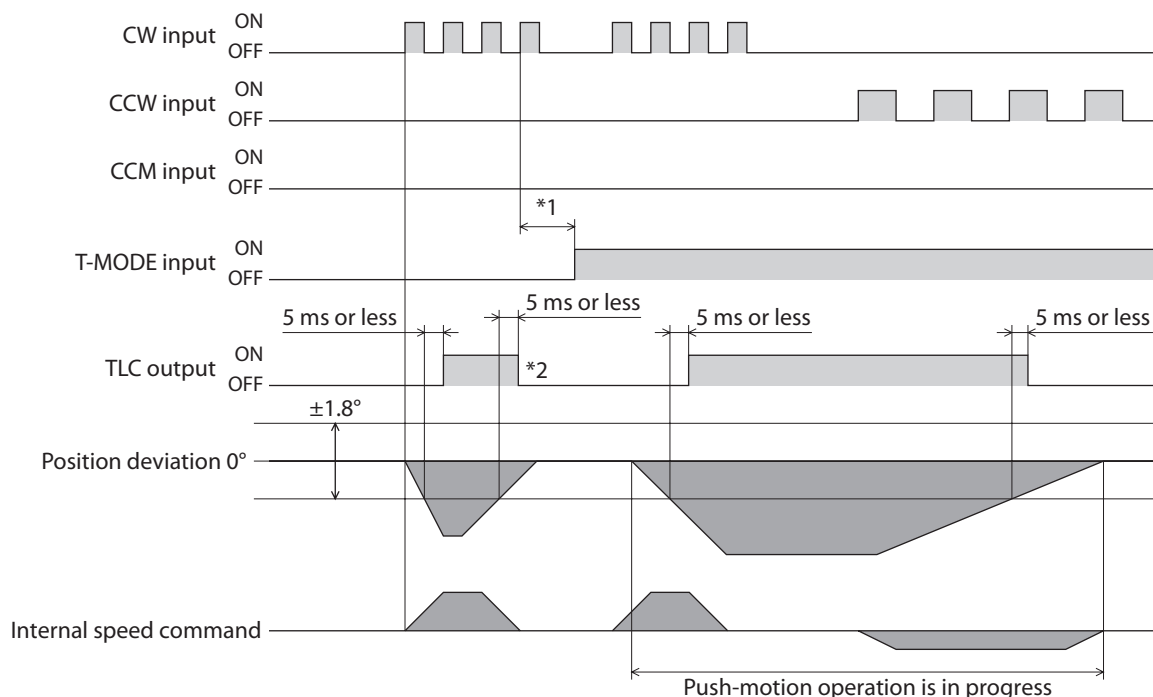

*1 Input the T-MODE signal while the motor is at standstill.

*2 When the position deviation exceeds $\pm 1.8^\circ$, the TLC signal will be output even during acceleration/deceleration.

● **Current control mode**

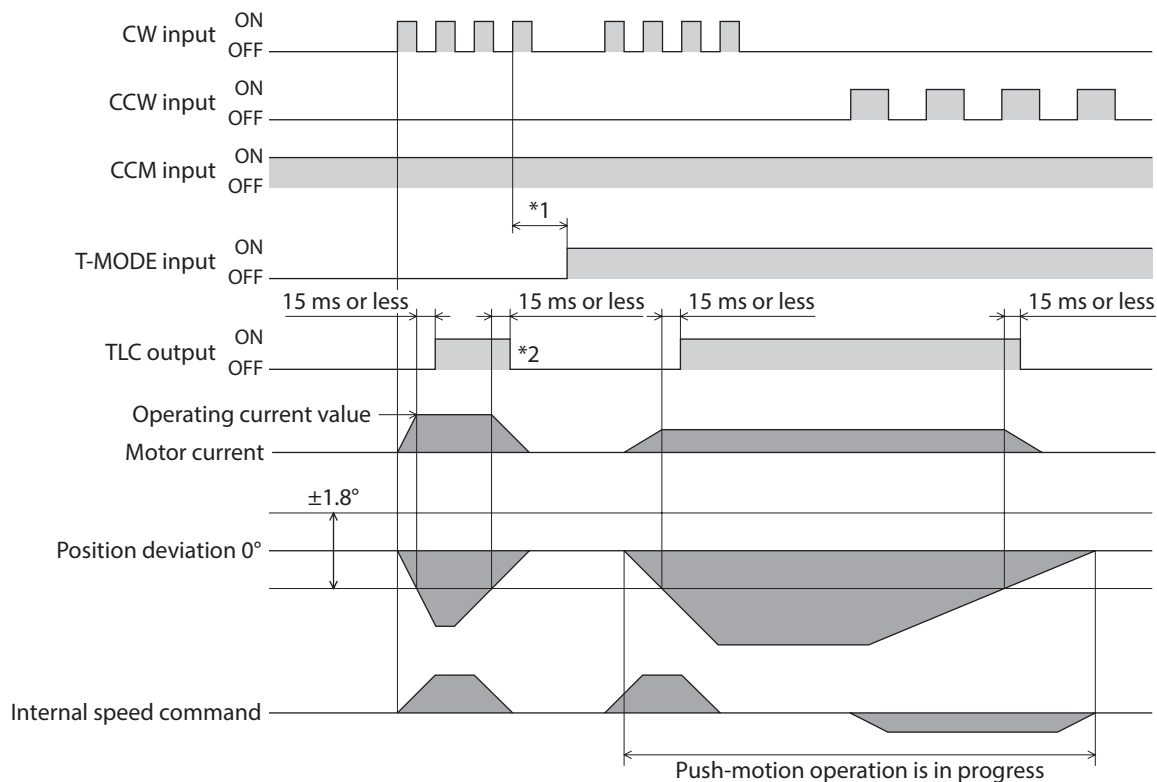

*1 Input the T-MODE signal while the motor is at standstill.

*2 When the motor current reaches the operating current, the TLC signal will be output even during acceleration/deceleration.

■ **END output**

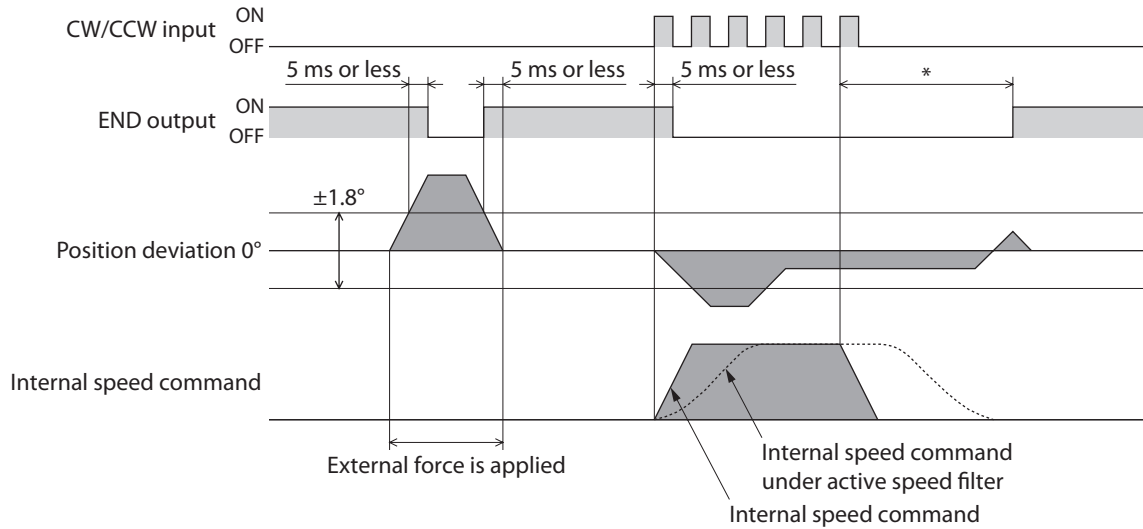

- * The output time of the END signal varies depending on the speed filter and operating speed.
- The END output will turn ON when the position deviation becomes $\pm 1.8^\circ$ and internal speed command is "0."

■ **TIM1 output/TIM2 output**

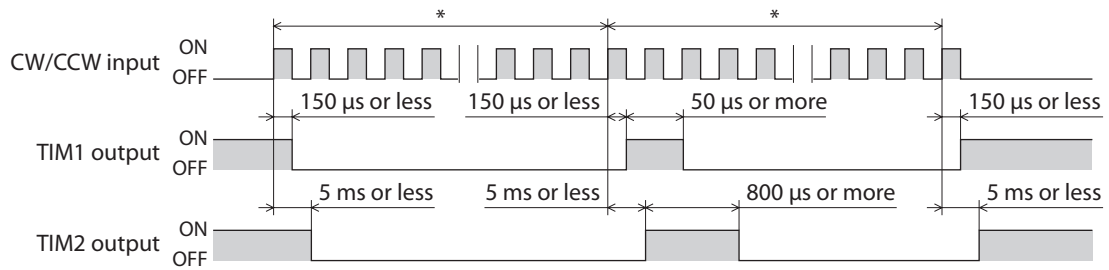

- * When pulses corresponding to 1/50th the resolution are input (assuming that the resolution is a multiple of 50).
- This timing chart assumes that an operation starts from the position where the TIM output turns ON.
- The TIM1 output is a line driver output, while the TIM2 output is an open collector output.

■ **Operation by pulse input**

- **Positioning operation**

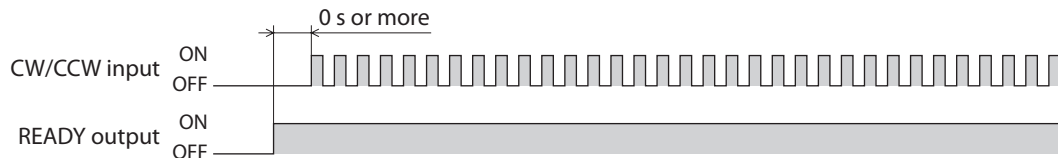

● When an error occurs (AC power input)

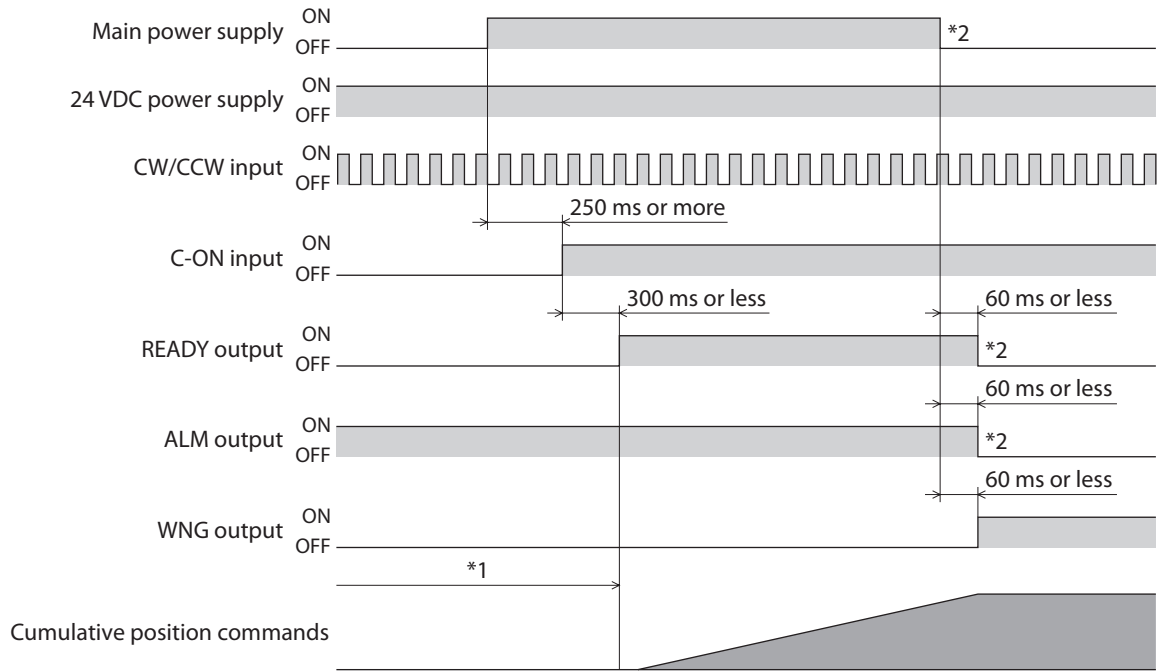

*1 When the READY output is OFF, input pulses are ignored.

*2 If a pulse is input while the main power is cut off, a main power supply error alarm will generate.

■ Return to electrical home operation

● When operation is interrupted

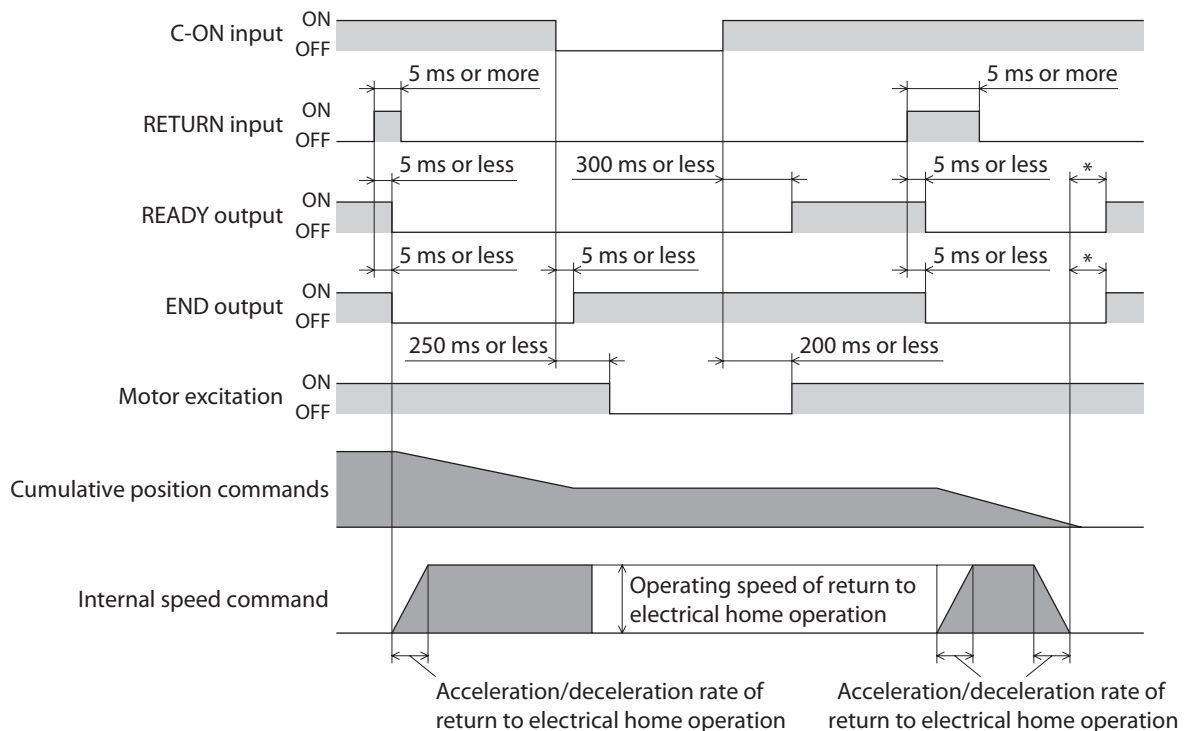

* The output time of the END signal varies depending on the speed filter and operating speed.

- If the C-ON input is turned OFF while a return to electrical home operation is still in progress, the operation will be interrupted. When the C-ON input is turned ON again and then the RETURN input is turned ON, the operation will resume from the position where it was interrupted.
- Return to electrical home operation can also be interrupted with the FREE input or CLR input. Note, however, that when a return to electrical home operation is interrupted using the CLR input, motor excitation will not turn off.

● Operation is terminated with the P-RESET input

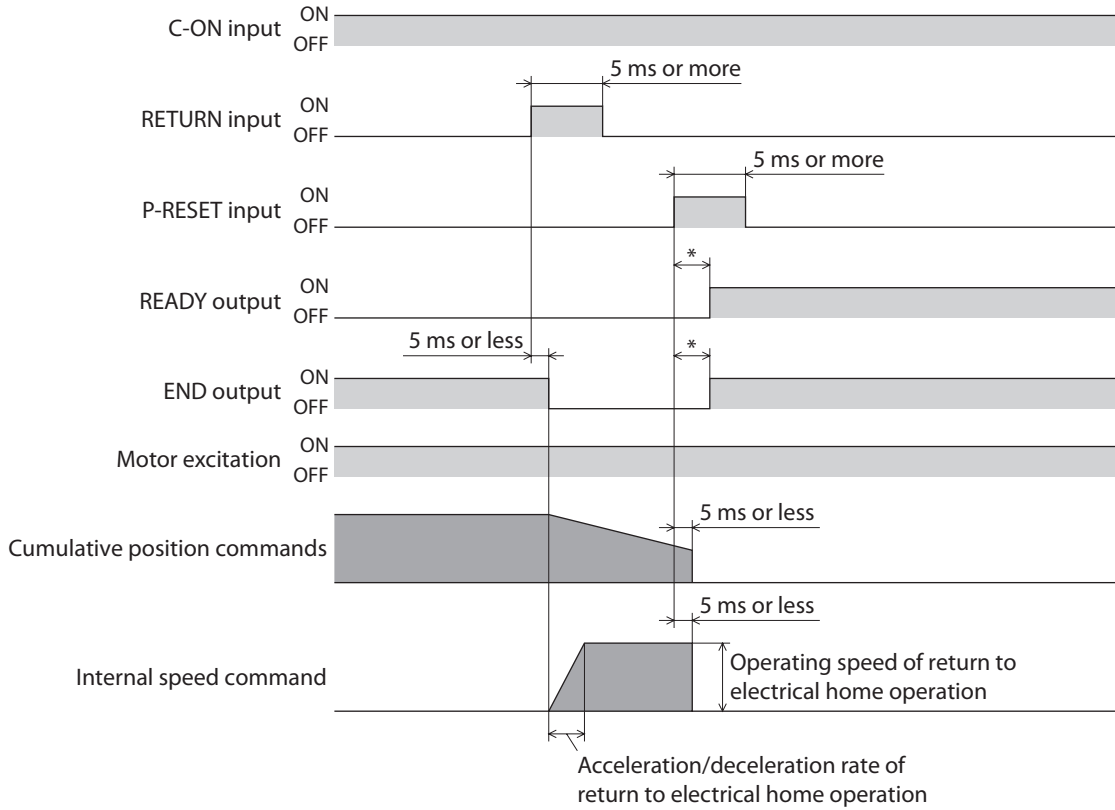

* The output time of the END signal varies depending on the speed filter and operating speed.

- When the P-RESET input is turned ON, the cumulative value of position commands will be reset to "0" and the current position will be set as the electrical home position. Accordingly, the return to electrical home operation will end.

■ Automatic return operation

● Position deviation occurs due to cutoff of the main power supply (AC power input)

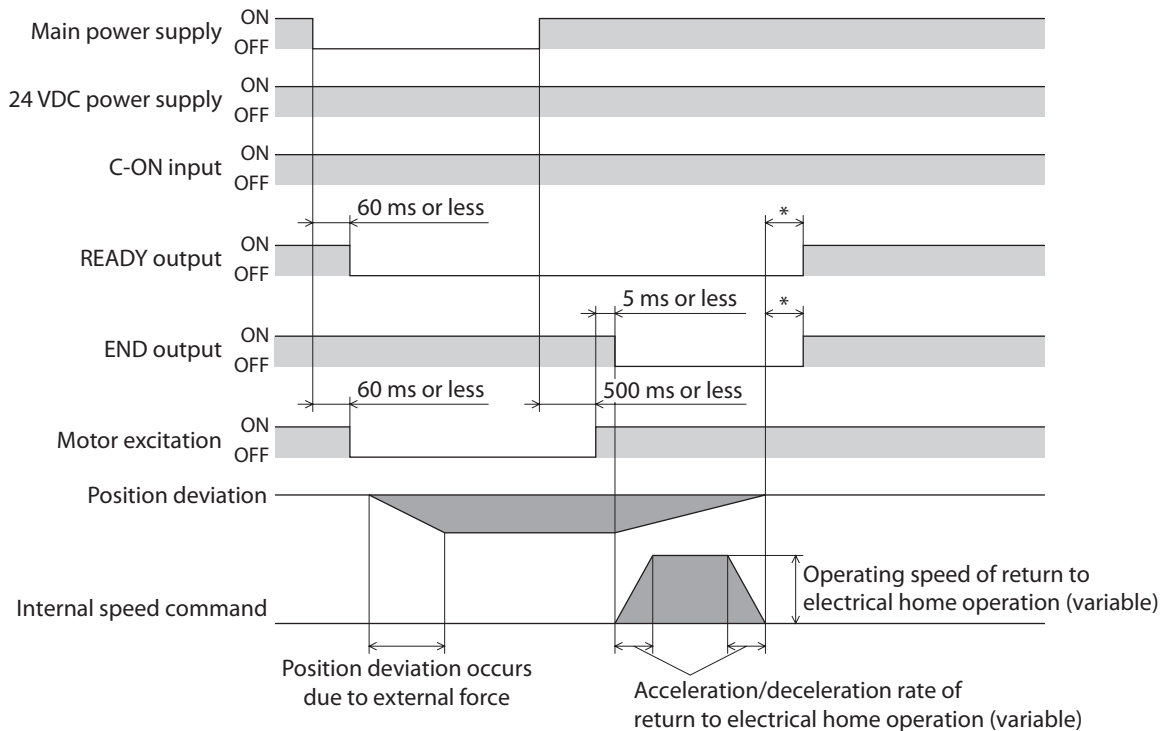

* The output time of the END signal varies depending on the speed filter and operating speed.

● Position deviation occurs due to turning OFF of the C-ON input

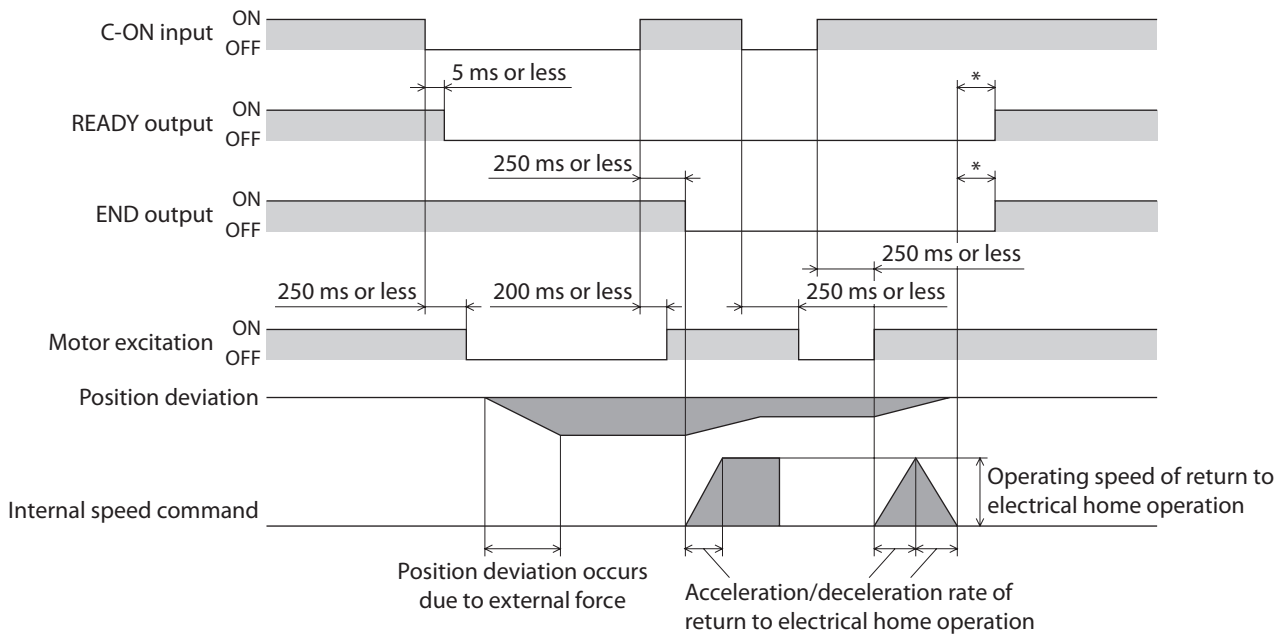

* The output time of the END signal varies depending on the speed filter and operating speed.

- If the C-ON input is turned OFF while automatic return operation is still in progress, the operation will be interrupted. When the C-ON input is turned ON again, the return operation will resume.
- Automatic return operation can also be interrupted using the FREE input.

● Operation is terminated with the CLR input

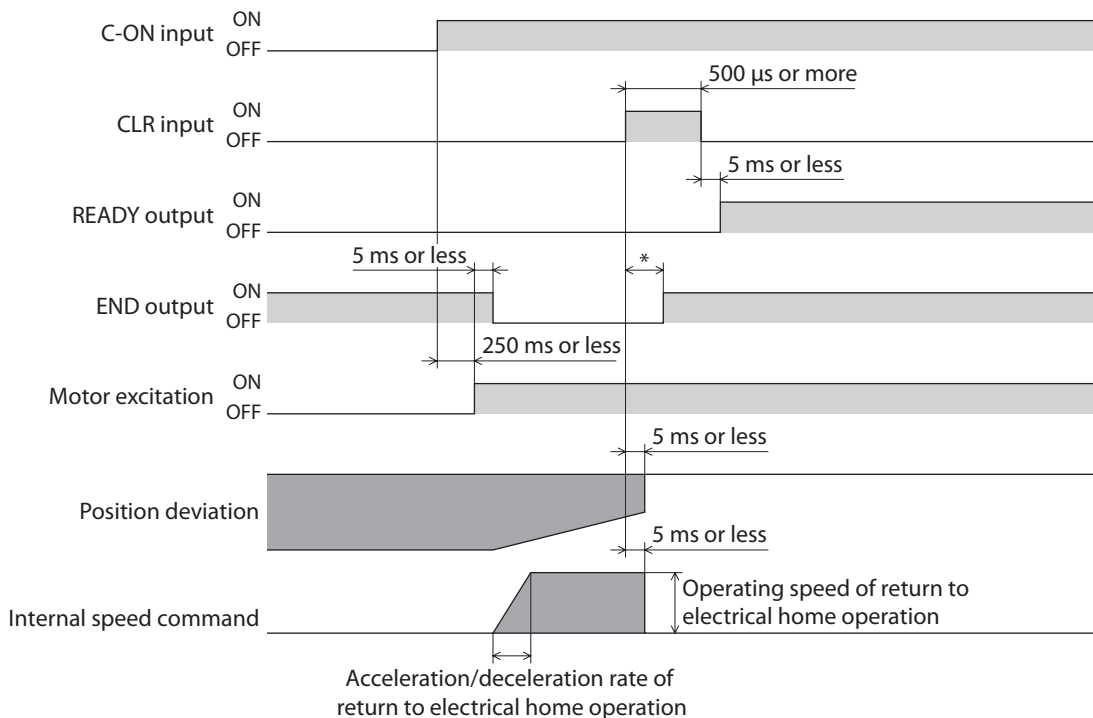

* The output time of the END signal varies depending on the speed filter and operating speed.

- When the CLR input is turned ON, the position deviation will be cleared. Accordingly, the return operation will end.

■ **ALM output/WNG output (AC power input)**

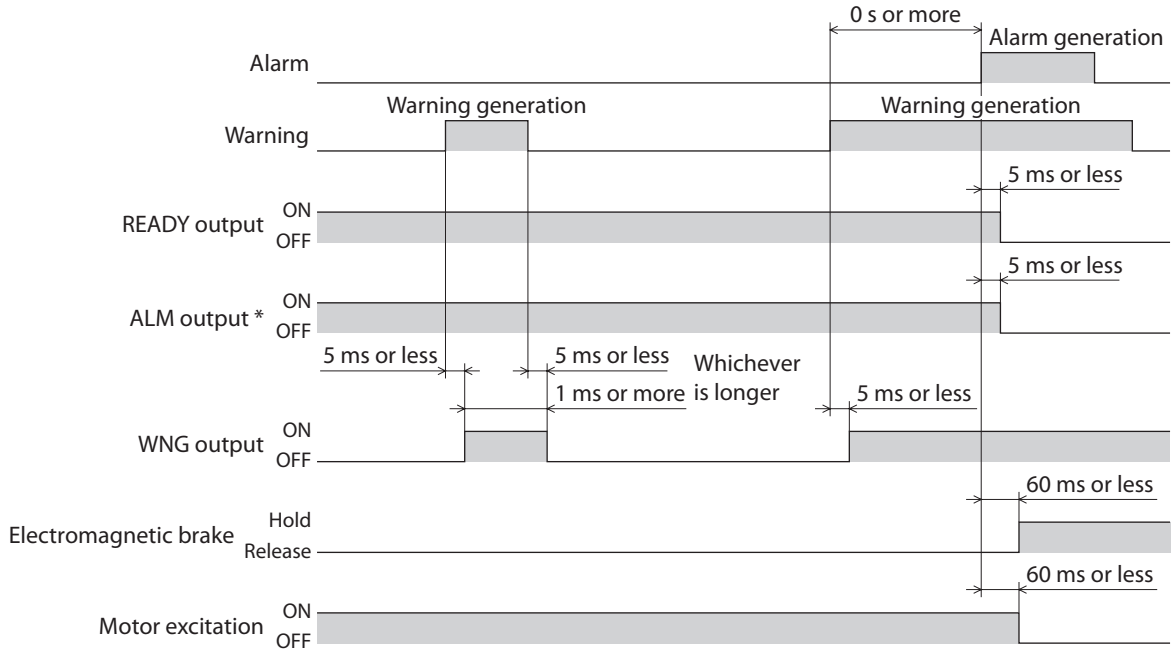

* An alarm code is also output at the same timing.

- This timing chart assumes generation of an alarm that turns off motor excitation.
- Some alarms do not turn off motor excitation.
- Some alarms are not preceded by a warning.

■ **ALM output/WNG output (DC power input)**

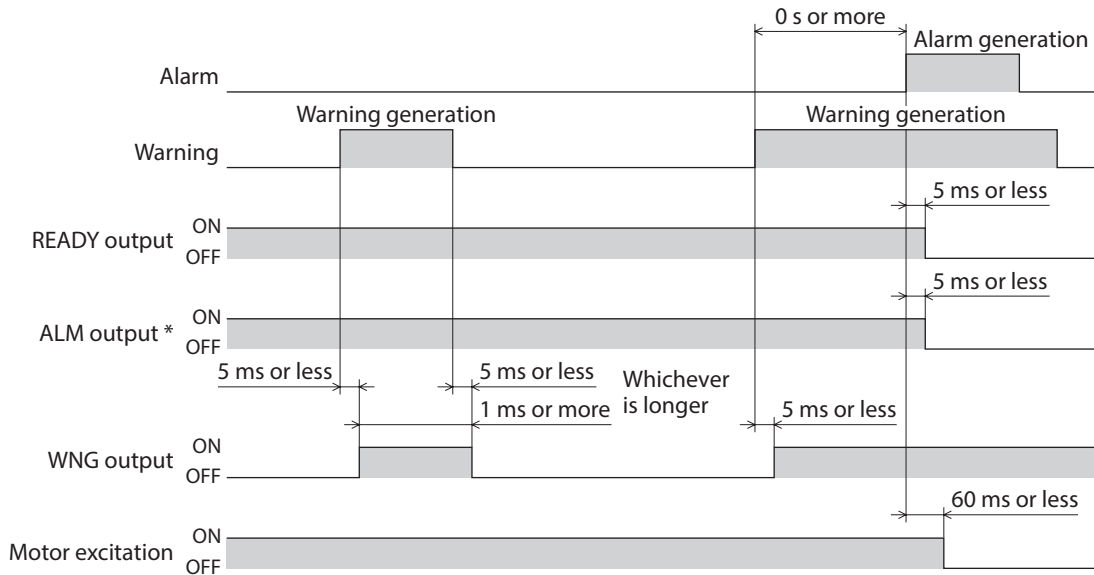

* An alarm code is also output at the same timing.

- This timing chart assumes generation of an alarm that turns off motor excitation.
- Some alarms do not turn off motor excitation.
- Some alarms are not preceded by a warning.

2 Specifications

Check on the Oriental Motor Website for the product specifications.

3 General specifications

3-1 AC power input

		Motor	Driver
Operation environment	Degree of protection	IP65 (Excluding the mounting surface and connectors.) IP20 (Double shaft type)	IP20
	Ambient temperature	-10 to +50 °C (+14 to +122 °F) *1 (non-freezing) Harmonic geared type: 0 to +40 °C (+32 to +104 °F) *1 (non-freezing)	0 to +50 °C (+32 to +122 °F) *2 (non-freezing)
	Humidity	85% or less (non-condensing)	
	Altitude	Up to 1000 m (3300 ft.) above sea level	
	Surrounding atmosphere	No corrosive gas, dust, water or oil	
Storage environment	Ambient temperature	-20 to +60 °C (-4 to +140 °F) (non-freezing)	
	Humidity	85% or less (non-condensing)	
	Altitude	Up to 3000 m (10000 ft.) above sea level	
	Surrounding atmosphere	No corrosive gas, dust, water or oil	
Shipping environment	Ambient temperature	-20 to +60 °C (-4 to +140 °F) (non-freezing)	
	Humidity	85% or less (non-condensing)	
	Altitude	Up to 3000 m (10000 ft.) above sea level	
	Surrounding atmosphere	No corrosive gas, dust, water or oil	
Insulation resistance		100 MΩ or more when 500 VDC megger is applied between the following places: <ul style="list-style-type: none"> • Case - Motor and sensor windings • Case - Electromagnetic brake windings 	100 MΩ or more when 500 VDC megger is applied between the following places: <ul style="list-style-type: none"> • Protective Earth Terminal - Power supply terminals • Signal I/O terminals - Power supply terminals
Dielectric strength		Sufficient to withstand the following for 1 minute. <ul style="list-style-type: none"> • Case - Motor and sensor windings 1.5 kVAC 50/60 Hz • Case - Electromagnetic brake windings 1.5 kVAC 50/60 Hz 	Sufficient to withstand the following for 1 minute. <ul style="list-style-type: none"> • Protective Earth Terminal - Power supply terminals 1.5 kVAC 50/60 Hz • Signal I/O terminals - Power supply terminals 1.8 kVAC 50/60 Hz

*1 When installing a motor to a heat sink of a capacity at least equivalent to an aluminum plate [250×250 mm (9.84×9.84 in.), thickness 6 mm (0.24 in.)].

*2 When installing a motor to a heat sink of a capacity at least equivalent to an aluminum plate [200×200 mm (7.87×7.87 in.), thickness 2 mm (0.08 in.)].

3-2 DC power input

		Motor	Driver
Operation environment	Degree of protection	IP65 (Excluding the mounting surface and connectors.) IP20 (Double shaft type, models that the "motor identification" in the product model name is "S")	IP20
	Ambient temperature	–10 to +50 °C (+14 to +122 °F) *1 (non-freezing) Harmonic geared type: 0 to +40 °C (+32 to +104 °F) *1 (non-freezing)	0 to +50 °C (+32 to +122 °F) (non-freezing)
	Humidity	85% or less (non-condensing)	
	Altitude	Up to 1000 m (3300 ft.) above sea level	
	Surrounding atmosphere	No corrosive gas, dust, water or oil	
Storage environment	Ambient temperature	–20 to +60 °C (–4 to +140 °F) (non-freezing)	
	Humidity	85% or less (non-condensing)	
	Altitude	Up to 3000 m (10000 ft.) above sea level	
	Surrounding atmosphere	No corrosive gas, dust, water or oil	
Shipping environment	Ambient temperature	–20 to +60 °C (–4 to +140 °F) (non-freezing)	
	Humidity	85% or less (non-condensing)	
	Altitude	Up to 3000 m (10000 ft.) above sea level	
	Surrounding atmosphere	No corrosive gas, dust, water or oil	
Insulation resistance		100 MΩ or more when 500 VDC megger is applied between the following places: <ul style="list-style-type: none"> • Case - Motor and sensor windings • Case - Electromagnetic brake windings 	–
Dielectric strength		Sufficient to withstand the following for 1 minute. <ul style="list-style-type: none"> • Case - Motor and sensor windings 1.0 kVAC 50/60 Hz *2 • Case - Electromagnetic brake windings 1.0 kVAC 50/60 Hz *2 	–

*1 When installing a motor to a heat sink of a capacity at least equivalent to an aluminum plate [100×100 mm (3.94×3.94 in.), thickness 6 mm (0.24 in.)].

*2 0.5 kVAC for the ARM14, ARM15, ARM24 and ARM26 types

4 Regulations and standards

4-1 UL Standards

Check the "APPENDIX UL Standards for **AR Series**" for recognition information about UL Standards.

4-2 EU Directives

■ CE Marking (AC power input)

This product is affixed the CE Marking under the Low Voltage Directive and EMC Directive.

● Low Voltage Directive

This product is certified by TÜV Rheinland under the EN 60034-1 and EN 61800-5-1.

	Motor	Driver
Applicable Standards	EN 60034-1, EN 60034-5, EN 60664-1	EN 50178, EN 61800-5-1
Installation conditions	To be incorporated in equipment Overvoltage category: II Pollution degree: 3 (2 for the double-shaft type) Protection against electric shock: Class I	To be incorporated in equipment Overvoltage category: II Pollution degree: 2 Protection against electric shock: Class I

- This product cannot be used in IT power distribution systems.
- When a product can be touched with hands, be sure to ground. When installing the motor and driver, securely connect their Protective Earth Terminals.
- To protect against electric shock using an earth leakage breaker (RCD), connect a type B earth leakage breaker to the primary side of the driver.
- When using a circuit breaker (MCCB), use a unit conforming to the EN or IEC standard.
- Isolate the motor cable, power-supply cable and other drive cables from the signal cables (CN1, CN4 and CN5) by means of double insulation.
- The temperature of the driver's heat sink may exceed 90 °C (194 °F) depending on the driving conditions. Accordingly, take heed of the following items:
 - Do not touch the driver.
 - Do not use the driver near flammable objects.
 - Always conduct a trial operation to check the driver temperature.

● EMC Directives

This product is conducted EMC testing under the conditions specified in "Example of motor and driver installation and wiring" on p.49. The conformance of your mechanical equipment with the EMC Directive will vary depending on such factors as the configuration, wiring, and layout for other control system devices and electrical parts used with this product. It therefore must be verified through conducting EMC measures in a state where all parts including this product have been installed in the equipment.

Applicable Standards

EMI	EN 55011 group 1 class A, EN 61000-6-4, EN 61800-3, EN 61000-3-2, EN 61000-3-3
EMS	EN 61000-6-2, EN 61800-3

CAUTION

This equipment is not intended for use in residential environments nor for use on a low-voltage public network supplied in residential premises, and it may not provide adequate protection to radio reception interference in such environments.

■ CE Marking (DC power input)

● Low Voltage Directive

The input power supply voltage of this product is 24 VDC/48 VDC. Therefore this product is not subject to the Low Voltage Directive, but install and connect it as follows.

- This product is designed and manufactured to be incorporated in equipment. Be sure to install the product in an enclosure.
- For the driver power supply, use a DC power supply with reinforced insulation on its primary and secondary sides.

● EMC Directives

This product is conducted EMC testing under the conditions specified in "Example of motor and driver installation and wiring" on p.85. The conformance of your mechanical equipment with the EMC Directive will vary depending on such factors as the configuration, wiring, and layout for other control system devices and electrical parts used with this product. It therefore must be verified through conducting EMC measures in a state where all parts including this product have been installed in the equipment.

Applicable Standards

EMI	EN 55011 group 1 class A, EN 61000-6-4
EMS	EN 61000-6-2

CAUTION

This equipment is not intended for use in residential environments nor for use on a low-voltage public network supplied in residential premises, and it may not provide adequate protection to radio reception interference in such environments.

4-3 Republic of Korea, Radio Waves Act

This product is affixed the KC Mark under the Republic of Korea, Radio Waves Act.

4-4 RoHS Directive

The products do not contain the substances exceeding the restriction values of RoHS Directive (2011/65/EU).

■ Revision record

Revision number	Revised contents
First edition	
Second edition	<ul style="list-style-type: none">• Removal of discontinued products described in “5 Precautions for use” of “1 Introduction”• Revision of words and terms• Correction of minor erroneous descriptions

- Unauthorized reproduction or copying of all or part of this Operating Manual is prohibited.
If a new copy is required to replace an original manual that has been damaged or lost, please contact your nearest Oriental Motor branch or sales office.
- Oriental Motor shall not be liable whatsoever for any problems relating to industrial property rights arising from use of any information, circuit, equipment or device provided or referenced in this manual.
- Characteristics, specifications and dimensions are subject to change without notice.
- While we make every effort to offer accurate information in the manual, we welcome your input. Should you find unclear descriptions, errors or omissions, please contact the nearest office.
- **Orientalmotor** and **αSTEP** are registered trademark or trademark of Oriental Motor Co., Ltd., in Japan and other countries. Other product names and company names mentioned in this manual may be registered trademarks or trademarks of their respective companies and are hereby acknowledged. The third-party products mentioned in this manual are recommended products, and references to their names shall not be construed as any form of performance guarantee. Oriental Motor is not liable whatsoever for the performance of these third-party products.

© Copyright ORIENTAL MOTOR CO., LTD. 2016

Published in January 2018

- Please contact your nearest Oriental Motor office for further information.

ORIENTAL MOTOR U.S.A. CORP.
Technical Support Tel:(800)468-3982
8:30 A.M. to 5:00 P.M., P.S.T. (M-F)
7:30 A.M. to 5:00 P.M., C.S.T. (M-F)
www.orientalmotor.com

ORIENTAL MOTOR DO BRASIL LTDA.
Tel:+55-11-3266-6018
www.orientalmotor.com.br

ORIENTAL MOTOR (EUROPA) GmbH
Schiessstraße 44, 40549 Düsseldorf, Germany
Technical Support Tel:00 800/22 55 66 22
www.orientalmotor.de

ORIENTAL MOTOR (UK) LTD.
Tel:01256-347090
www.oriental-motor.co.uk

ORIENTAL MOTOR (FRANCE) SARL
Tel:01 47 86 97 50
www.orientalmotor.fr

ORIENTAL MOTOR ITALIA s.r.l.
Tel:02-93906346
www.orientalmotor.it

ORIENTAL MOTOR ASIA PACIFIC PTE. LTD.
Singapore
Tel:1800-8420280
www.orientalmotor.com.sg

ORIENTAL MOTOR (MALAYSIA) SDN. BHD.
Tel:1800-806161
www.orientalmotor.com.my

ORIENTAL MOTOR (THAILAND) CO., LTD.
Tel:1800-888-881
www.orientalmotor.co.th

ORIENTAL MOTOR (INDIA) PVT. LTD.
Tel:+91-80-41125586
www.orientalmotor.co.in

TAIWAN ORIENTAL MOTOR CO., LTD.
Tel:0800-060708
www.orientalmotor.com.tw

SHANGHAI ORIENTAL MOTOR CO., LTD.
Tel:400-820-6516
www.orientalmotor.com.cn

INA ORIENTAL MOTOR CO., LTD.
Korea
Tel:080-777-2042
www.inaom.co.kr

ORIENTAL MOTOR CO., LTD.
Hong Kong Branch
Tel:+852-2427-9800

ORIENTAL MOTOR CO., LTD.
4-8-1 Higashiueno, Taito-ku, Tokyo
110-8536 Japan
Tel:03-6744-0361
www.orientalmotor.co.jp