



αSTEP **ASC Series**

OPERATING MANUAL



Thank you for purchasing an Oriental Motor product.

This Operating Manual describes product handling procedures and safety precautions.

- Please read it thoroughly to ensure safe operation.
- Always keep the manual where it is readily available.

Table of Contents

1	Introduction	2	6.4	Connecting the electromagnetic brake motor	29
2	Safety precautions	5	6.5	Connecting the power supply for the electromagnetic brake	30
3	Precautions for use	8	6.6	Connecting the control input/output	31
4	Preparation	11	6.7	About control input/output	33
4.1	Checking the product	11	6.8	Timing chart	40
4.2	Combinations of motors and drivers	12	7	Setting	41
4.3	Names and functions of parts ...	14	7.1	Resolution	41
5	Installation	15	7.2	Pulse input modes	42
5.1	Location for installation	15	7.3	Operating current	43
5.2	Installing the motor	15	7.4	Speed filter	44
5.3	Installing a load	17	8	Protective functions	45
5.4	Permissible overhung load and permissible thrust load	18	8.1	Descriptions of protective functions and numbers of LED blinks	45
5.5	Installing the driver	20	8.2	How to clear a protective function	46
5.6	Installing and wiring in compliance with EMC Directive	21	9	Inspection	47
6	Connection	25	10	Troubleshooting and remedial actions	48
6.1	Connection example	25	11	Options (Sold separately)	51
6.2	Connecting to the power supply	28			
6.3	Connecting the standard type motor	29			

1 Introduction

■ Before use

Only qualified personnel should work with the product.

Use the product correctly after thoroughly reading the section “2 Safety precautions” on page 5.

The product described in this manual has been designed and manufactured for use in general industrial machinery, and must not be used for any other purpose. Oriental Motor Co., Ltd. is not responsible for any damage caused through failure to observe this warning.

■ Overview of the product

The *αSTEP ASC* series models are unit products consisting of a high-performance 24 VDC input micro-stepping driver and a stepping motor (*αSTEP*) having a built-in rotor position sensor. The *αSTEP ASC* series models are not subject to missteps, even when the load changes suddenly. The speed and amount of rotation are constantly monitored during operation, so that when an overload is about to cause the motor to misstep, any delay in response is corrected and operation continues at maximum torque.

■ Standards and CE Marking

This product is recognized by UL and certified by CSA, and bears the CE Marking (EMC Directive) in compliance with the EN Standards.

● Applicable standards

	Applicable Standards	Certification Body	Standards File No.	CE Marking
Motor	UL 60950 CSA C22.2 No.60950	UL	E208200	EMC Directive
Driver	UL 508C CSA C22.2 No.14		E171462	
	UL 1950 CSA C22.2 No.950		E208200	

* Approval conditions for UL 60950 and UL 1950: Class III equipment, SELV circuit, Pollution degree 2

* For unit models, Oriental Motor declares conformance with the EMC Directive individually.

● For Low Voltage Directive

This product is not subject to the EC's Low Voltage Directive because its input power supply voltage is 24 VDC. However, the user is advised to perform the following steps when conducting product installation and connection.

- This product is designed for use within machinery, so it should be installed within an enclosure.
- For the driver, use a power supply with reinforced insulation on its primary and secondary sides.

- For EMC Directive (89/336/EEC, 92/31/EEC)

This product has received EMC measures under the conditions specified in “Example of DC power supply input specification installation and wiring” on page 24. Be sure to conduct EMC measures with the product assembled in your equipment by referring to 5.6 “Installing and wiring in compliance with EMC Directive” on page 21.

■ Hazardous substances

RoHS (Directive 2002/95/EC 27Jan.2003) compliant

■ Main features

- Low-speed operation at low vibration levels

The *QSTEP ASC* series achieves smooth, low-speed operation with extremely low vibration, thanks to its micro-stepping drive, which enables stepping in very small angles.

- Built-in alarm function

Whenever a load greatly exceeding the motor rating is encountered, or when the motor's output shaft is constrained during operation, the driver outputs a warning alarm. In a vertical-travel application, the electromagnetic brake may be triggered upon the detection of this alarm to prevent a moving section and the work from falling.

- Preset speed filter

The filter time constant that determines motor response can be set in 16 increments.

- Preset operating current

The level of motor current during operation can be set between 6 and 100% (maximum) in 16 increments.

- Preset resolution

The motor resolution levels can be set in four increments: 0.72°/pulse, 0.36°/pulse, 0.072°/pulse and 0.036°/pulse.

■ System configuration

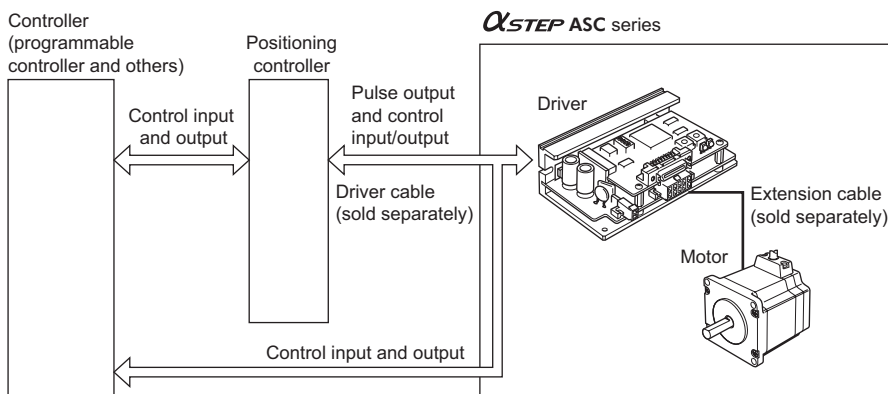

Controllers with pulse output functions are needed to operate the *αSTEP ASC* series.



Extension cables are available in two types: the standard type and the electromagnetic brake type. If you are using an electromagnetic brake motor, provide a 24 VDC power supply for the electromagnetic brake separately from the control power supply and always use an optional extension cable of the electromagnetic brake type (sold separately) for connection. The electromagnetic brake will not function if the motor cable is connected directly to the driver. The **ASC46** with electromagnetic brake uses a standard extension cable in conjunction with separate lead wires for the electromagnetic brake.

2 Safety precautions

The precautions described below are intended to prevent danger or injury to the user and other personnel through safe, correct use of the product. Use the product only after carefully reading and fully understanding these instructions.

 Warning	Handling the product without observing the instructions that accompany a “Warning” symbol may result in serious injury or death.
 Caution	Handling the product without observing the instructions that accompany a “Caution” symbol may result in injury or property damage.
<div style="background-color: black; color: white; padding: 2px 5px; display: inline-block;">Note</div>	The items under this heading contain important handling instructions that the user should observe to ensure safe use of the product.

 **Warning**

General

- Do not use the product in explosive or corrosive environments, in the presence of flammable gases, locations subjected to splashing water, or near combustibles. Doing so may result in fire or injury.
- Assign qualified personnel the task of installing, wiring, operating/controlling, inspecting and troubleshooting the product. Failure to do so may result in fire or injury.
- Provide a means to hold the moving parts in place for applications involving vertical travel. The motor loses holding torque when the power is shut off, allowing the moving parts to fall and possibly cause injury or damage to equipment.
- Do not use the motor’s built-in electromagnetic brake mechanism for stopping or for safety purposes. Using it for purposes other than holding the moving parts and motor in position may cause injury or damage to equipment.
- When the driver’s protective function is triggered, the motor will stop and lose its holding torque, possibly causing injury or damage to equipment.
- When the driver’s protective function is triggered, first remove the cause and then clear the protective function. Continuing the operation without determining the cause of the problem may cause malfunction of the motor, leading to injury or damage to equipment.

Installation

- Install the motor and driver in their enclosures in order to prevent injury.

Connection

- Keep the driver's power supply input voltage within the specified range to avoid fire.
- For the driver's power supply use a DC power supply with reinforced insulation on its primary and secondary sides. Failure to do so may result in electric shock.
- Connect the cables securely according to the wiring diagram in order to prevent fire.
- Do not forcibly bend, pull or pitch the cable. Doing so may result in fire.

Operation

- Turn off the driver power in the event of a power failure, otherwise the motor may suddenly start when the power is restored and may cause injury or damage to equipment.
- Do not turn the C.OFF (All windings off) input to "ON" while the motor is operating. The motor will stop and lose its holding ability, which may result in injury or damage to equipment.

Repair, disassembly and modification

- Do not disassemble or modify the motor or driver. This may cause injury. Refer all such internal inspections and repairs to the branch or sales office from which you purchased the product.



General

- Do not use the motor and driver beyond their specifications, or injury or damage to equipment may result.
- Keep your fingers and objects out of the openings in the motor and driver, or fire or injury may occur.
- Do not touch the motor or driver during operation or immediately after stopping. The surfaces are hot and may cause a burn.

Transportation

- Do not hold the motor output shaft or motor cable. This may cause injury.

Installation

- Keep the area around the motor and driver free of combustible materials in order to prevent fire or a burn.
- To prevent the risk of damage to equipment, leave nothing around the motor and driver that would obstruct ventilation.
- Provide a cover over the rotating parts (output shaft) of the motor to prevent injury.

Operation

- Use the motor and driver only in the specified combination. An incorrect combination may cause a fire.
- Provide an emergency-stop device or emergency-stop circuit external to the equipment so that the entire equipment will operate safely in the event of a system failure or malfunction. Failure to do so may result in injury.
- Before supplying power to the driver, turn all control inputs to the driver to “OFF.” Otherwise, the motor may start suddenly and cause injury or damage to equipment.
- To prevent bodily injury, do not touch the rotating parts (output shaft) of the motor during operation.
- Before moving the motor directly (as in the case of manual positioning), confirm that the driver C.OFF (All windings off) input is “ON” to prevent injury.
- The motor’s surface temperature may exceed 70 °C (158 °F), even under normal operating conditions. If a motor is accessible during operation, post a warning label shown in the figure in a conspicuous position to prevent the risk of burns.
- For the control input and output power supply, use a power supply with reinforced insulation provided on the primary side, and provide it separately from the power supply for the electromagnetic brake. Failure to do so may result in electric shock.
- Immediately when trouble has occurred, stop running and turn off the driver power. Failure to do so may result in fire or injury.



Warning
label

Disposal

- To dispose of the motor or driver, disassemble it into parts and components as much as possible and dispose of individual parts/components as industrial waste.

3 Precautions for use

This section covers limitations and requirements the user should consider when using the *αSTEP ASC* series.

- **Conduct the insulation resistance measurement or withstand voltage test separately on the motor and the driver.**

Conducting the insulation resistance measurement or withstand voltage test with the motor and driver connected may result in damage to equipment.

- **Do not apply an overhung load and thrust load in excess of the specified permissible limit.**

Be sure to operate the motor within the specified permissible limit of overhung load and thrust load. Operating it under an excessive overhung load and thrust load may damage the motor bearings (ball bearings). See page 18 for details.

- **Operate the motor with a surface temperature not exceeding 100 °C (212 °F).**

The driver has an overheat-protection function, but the motor has no such feature. The motor case's surface temperature may exceed 100 °C (212 °F) under certain conditions (ambient temperature, operating speed, duty cycle, etc.). Keeping the surface temperature of the motor casing below 100 °C (212 °F) will also maximize the life of the motor bearings (ball bearings).

Use the harmonic geared type motor in a condition where the gear case temperature does not exceed 70 °C (158 °F), in order to prevent deterioration of grease in the gear.

- **About maximum static torque at excitation**

Maximum static torque at excitation represents a value obtained when the motor is excited using a rated current. When combined with a dedicated driver and while the motor is stopped motor-temperature increases are suppressed due to a current-reduction of approximately 50% by the current-cutback function.

Acceleration and operation at the maximum static torque at excitation is possible in start-up, but it has approximately 50% holding power after it has stopped. When selecting a motor for your application, consider the fact that the holding power will be reduced to approximately 50% after the motor has stopped.

- **Use an electromagnetic brake motor for an application involving up/down travel.**

When the motor is used in an application involving up/down travel, use an electromagnetic brake motor to hold the load in position. To hold the load in position, apply the electromagnetic brake only after the motor has stopped. Do not use the brake to bring the moving motor to a halt. Repeated braking for such a purpose will wear the brake hub excessively, causing its holding ability to drop.

Since the electromagnetic brake is of the non-excitation type, it can also be used to hold the load in position upon the occurrence of a power failure. However, this is not a secure means of holding the load. Do not use the electromagnetic brake as a safety brake.

When the driver-protection function is triggered, the motor stops as the current is turned off. The user must set a controller sequence that will cut off the power to the electromagnetic brake and hold the load in position upon detecting an “OFF” ALARM output.

- **Connecting an electromagnetic brake motor**

When using an electromagnetic brake motor, provide a power supply for the electromagnetic brake separately from the control I/O power supply.

ASC46

Connect the lead wires of the electromagnetic brake to the DC power supply while ensuring the correct polarities of the leads. Be sure to connect the supplied non-polarized varistor in order to protect the switch contacts and prevent noise.

ASC66

Always use an optional extension cable of the electromagnetic brake type when connecting the motor to the driver. Connect the two lead wires for the electromagnetic brake, which extend from the extension cable, to the DC power supply while ensuring the correct polarities of the leads.

Be sure to connect the supplied non-polarized varistor in order to protect the switch contacts and prevent noise.

- **Preventing electrical noise**

See 5.6 “Installing and wiring in compliance with EMC Directive” on page 21 for measures with regard to noise.

- Geared type motors

Backlash

The **TH** gear output shaft is subject to backlash of 10 to 60'. The **PN** gear output shaft is subject to backlash of 2 to 3'. Backlash refers to the looseness at the gear output shaft, as generated when the input side of the gear is fixed.

To reduce the effect of backlash, positioning should be from one direction only-either from the CW direction or the CCW direction.

About maximum torque

Always operate the geared type motor under a load not exceeding the maximum torque. If the load exceeds the maximum torque, the gear will be damaged.

Rotating direction of the gear output shaft

The relationship between the rotating direction of the motor shaft and that of the gear output shaft changes as follows, depending on the gear type and gear ratio.

Gear type	Gear ratio	Rotating direction (Relative to the motor rotation direction)		
		Frame size		
		28 mm (1.1 in.)	42 mm (1.65 in.)	60 mm (2.36 in.)
TH gear	3.6:1, 7.2:1, 10:1	Opposite direction	Same direction	
	20:1, 30:1	Same direction	Opposite direction	
PN gear	5:1, 7.2:1, 10:1, 25:1, 36:1, 50:1	Same direction		
Harmonic gear	50:1, 100:1	Opposite direction		

About grease of geared motor

On rare occasions, a small amount of grease may ooze out from the geared motor. If there is concern over possible environmental damage resulting from the leakage of grease, check for grease stains during regular inspections. Alternatively, install an oil pen or other device to prevent leakage from causing further damage. Oil leakage may lead to problems in the customer's equipment or products.

4 Preparation

This section covers the points to be checked along with the names and functions of respective parts.

4.1 Checking the product

Upon opening the package, verify that the items listed below are included. Report any missing or damaged items to the branch or sales office from which you purchased the product.

- Motor 1 unit
- Driver 1 unit
- Control input/output connector 1 set
- Power supply connector 5557-02R-210 (Molex) 1 pc.
- Power supply connector crimp terminal 5556TL (Molex) 2 pcs.
- Operating manual (this manual) 1 copy
- Varistor 1 pc.*

* Varistor supplied with the motor with an electromagnetic brake.

Note

When removing the driver from the conductive protection bag, make sure your hands are not charged with static electricity. This is to prevent damage to the driver due to static electricity.

Verify the model number of the purchased unit against the number shown on the package label. Check the model number of the motor and driver against the number shown on the nameplate. The unit models and corresponding motor/driver combinations are listed on page 12.

4.2 Combinations of motors and drivers

Standard type

Unit model	Motor model	Driver model
ASC34AK	ASM34AK	ASD10A-K
ASC36AK	ASM36AK	ASD10B-K
ASC46AK	ASM46AK	ASD18A-K
ASC66AK	ASM66AK	ASD36A-K

TH geared type

Unit model	Motor model	Driver model
ASC34AK-T7.2	ASM34AK-T7.2	ASD10C-K
ASC34AK-T10	ASM34AK-T10	ASD10C-K
ASC34AK-T20	ASM34AK-T20	ASD10C-K
ASC34AK-T30	ASM34AK-T30	ASD10C-K
ASC46AK-T3.6	ASM46AK-T3.6	ASD18B-K
ASC46AK-T7.2	ASM46AK-T7.2	ASD18B-K
ASC46AK-T10	ASM46AK-T10	ASD18B-K
ASC46AK-T20	ASM46AK-T20	ASD18B-K
ASC46AK-T30	ASM46AK-T30	ASD18B-K
ASC66AK-T3.6	ASM66AK-T3.6	ASD36B-K
ASC66AK-T7.2	ASM66AK-T7.2	ASD36B-K
ASC66AK-T10	ASM66AK-T10	ASD36B-K
ASC66AK-T20	ASM66AK-T20	ASD36B-K
ASC66AK-T30	ASM66AK-T30	ASD36B-K

Standard type with electromagnetic brake

Unit model	Motor model	Driver model
ASC46MK	ASM46MK	ASD18A-K
ASC66MK	ASM66MK	ASD36A-K

TH geared type with electromagnetic brake

Unit model	Motor model	Driver model
ASC46MK-T3.6	ASM46MK-T3.6	ASD18B-K
ASC46MK-T7.2	ASM46MK-T7.2	ASD18B-K
ASC46MK-T10	ASM46MK-T10	ASD18B-K
ASC46MK-T20	ASM46MK-T20	ASD18B-K
ASC46MK-T30	ASM46MK-T30	ASD18B-K
ASC66MK-T3.6	ASM66MK-T3.6	ASD36B-K
ASC66MK-T7.2	ASM66MK-T7.2	ASD36B-K
ASC66MK-T10	ASM66MK-T10	ASD36B-K
ASC66MK-T20	ASM66MK-T20	ASD36B-K
ASC66MK-T30	ASM66MK-T30	ASD36B-K

PN geared type

Unit model	Motor model	Driver model
ASC34AK-N5	ASM34AK-N5	ASD10A-K
ASC34AK-N7.2	ASM34AK-N7.2	ASD10A-K
ASC34AK-N10	ASM34AK-N10	ASD10A-K
ASC46AK-N7.2	ASM46AK-N7.2	ASD18A-K
ASC46AK-N10	ASM46AK-N10	ASD18A-K
ASC66AK-N5	ASM66AK-N5	ASD36A-K
ASC66AK-N7.2	ASM66AK-N7.2	ASD36A-K
ASC66AK-N10	ASM66AK-N10	ASD36A-K
ASC66AK-N25	ASM66AK-N25	ASD36B-K
ASC66AK-N36	ASM66AK-N36	ASD36B-K
ASC66AK-N50	ASM66AK-N50	ASD36B-K

Harmonic geared type

Unit model	Motor model	Driver model
ASC34AK-H50	ASM34AK-H50	ASD10C-K
ASC34AK-H100	ASM34AK-H100	ASD10C-K
ASC46AK-H50	ASM46AK-H50	ASD18A-K
ASC46AK-H100	ASM46AK-H100	ASD18A-K
ASC66AK-H50	ASM66AK-H50	ASD36B-K
ASC66AK-H100	ASM66AK-H100	ASD36B-K

PN geared type with electromagnetic brake

Unit model	Motor model	Driver model
ASC46MK-N7.2	ASM46MK-N7.2	ASD18A-K
ASC46MK-N10	ASM46MK-N10	ASD18A-K
ASC66MK-N5	ASM66MK-N5	ASD36A-K
ASC66MK-N7.2	ASM66MK-N7.2	ASD36A-K
ASC66MK-N10	ASM66MK-N10	ASD36A-K
ASC66MK-N25	ASM66MK-N25	ASD36B-K
ASC66MK-N36	ASM66MK-N36	ASD36B-K
ASC66MK-N50	ASM66MK-N50	ASD36B-K

Harmonic geared type with electromagnetic brake

Unit model	Motor model	Driver model
ASC46MK-H50	ASM46MK-H50	ASD18A-K
ASC46MK-H100	ASM46MK-H100	ASD18A-K
ASC66MK-H50	ASM66MK-H50	ASD36 B-K
ASC66MK-H100	ASM66MK-H100	ASD36 B-K

4.3 Names and functions of parts

This section covers the names and functions of parts in the motor and driver.

• Motor

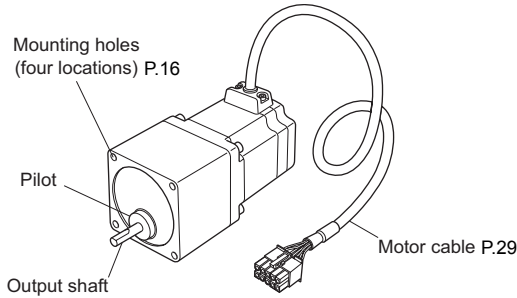

• Driver

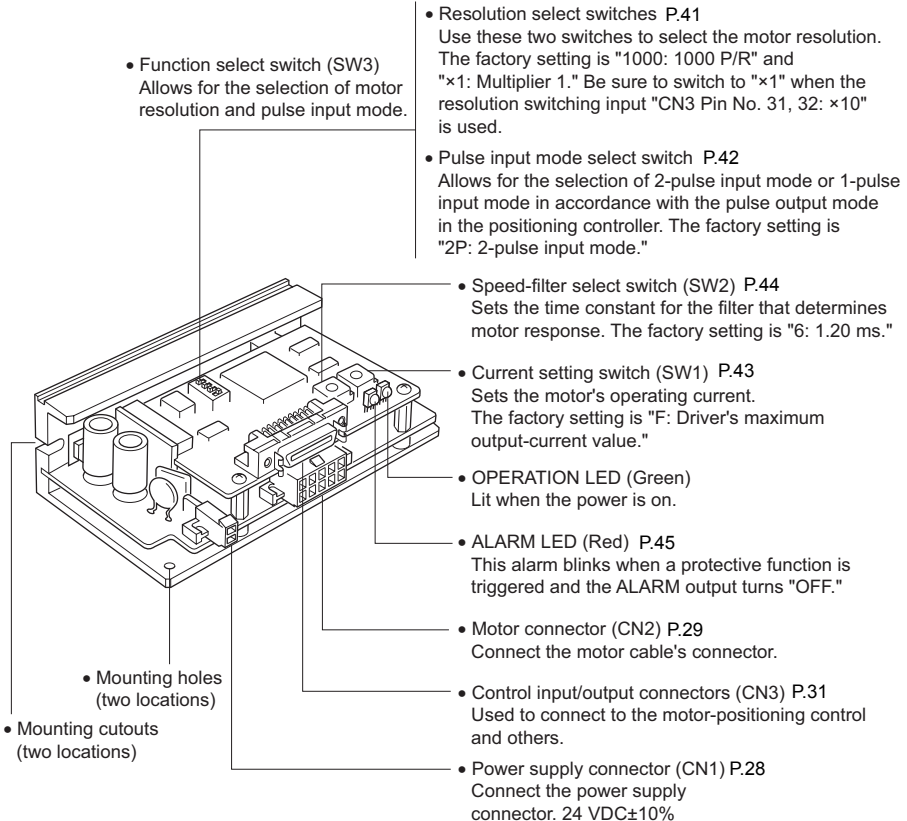

5 Installation

This section covers the environment and method of installing the motor and driver, along with load installation.

Also covered in this section are the installation and wiring methods that are in compliance with the relevant EMC Directive.

5.1 Location for installation

The motor and driver are designed and manufactured for installation in equipment. Install them in a well-ventilated location that provides easy access for inspection. The location must also satisfy the following conditions:

- Inside an enclosure that is installed indoors (provide vent holes)
- Operating ambient temperature
 - Motor: 0 to +50 °C (+32 to +122 °F) (non-freezing)
 - Harmonic geared type: 0 to +40 °C (+32 to +104 °F) (non-freezing)
 - Driver: 0 to +40 °C (+32 to +104 °F) (non-freezing)
- Operating ambient humidity 85% or less (non-condensing)
- Area that is free of explosive atmosphere or toxic gas (such as sulfuric gas) or liquid
- Area not exposed to direct sun
- Area free of excessive amount of dust, iron particles or the like
- Area not subject to splashing water (rains, water droplets), oil (oil droplets) or other liquids
- Area free of excessive salt
- Area not subject to continuous vibration or excessive shocks
- Area free of excessive electromagnetic noise (from welders, power machinery, etc.)
- Area free of radioactive materials, magnetic fields or vacuum

5.2 Installing the motor

■ Installation direction

The motor can be installed in any direction.

■ Installation method

Install the motor onto an appropriate flat metal plate having excellent vibration resistance and heat conductivity. When installing the motor, secure it with four bolts (not supplied) through the four mounting holes provided. Leave no gap between the motor and plate.

Note

Insert the pilot located on the motor's installation surface into the mounting plate's.

• Installation method A

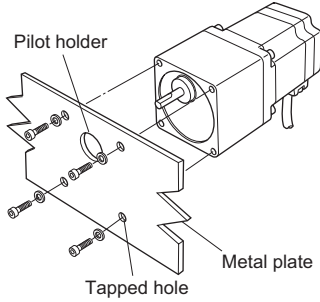

• Installation method B

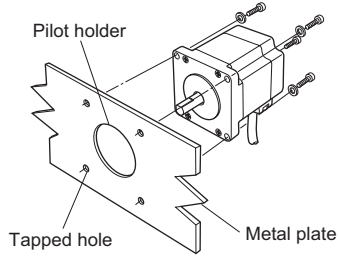

Motor type	Frame size	Bolt size	Tightening torque	Effective depth of bolt	Installation method
Standard	28 mm (1.1 in.)	M2.5	0.5 N·m (71 oz-in)	2.5 mm (0.098 in.)	A
	42 mm (1.65 in.)	M3	1 N·m (142 oz-in)	4.5 mm (0.177 in.)	
	60 mm (2.36 in.)	M4	2 N·m (280 oz-in)	—	B
TH geared	28 mm (1.1 in.)	M2.5	0.5 N·m (71 oz-in)	4 mm (0.157 in.)	A
	42 mm (1.65 in.)	M4	2 N·m (280 oz-in)	8 mm (0.315 in.)	
	60 mm (2.36 in.)				
PN geared	28 mm (1.1 in.)	M3	1 N·m (142 oz-in)	6 mm (0.236 in.)	A
	42 mm (1.65 in.)	M4	2 N·m (280 oz-in)	8 mm (0.315 in.)	
	60 mm (2.36 in.)	M5	2.5 N·m (350 oz-in)	10 mm (0.394 in.)	
Harmonic geared	28 mm (1.1 in.)	M3	1 N·m (142 oz-in)	6 mm (0.236 in.)	A
	42 mm (1.65 in.)	M4	2 N·m (280 oz-in)	8 mm (0.315 in.)	
	60 mm (2.36 in.)	M5	2.5 N·m (350 oz-in)	10 mm (0.394 in.)	

5.3 Installing a load

When connecting a load to the motor, align the centers of the motor's output shaft and load shaft.

The overhung load and the thrust load must be kept within the permissible values. Optional flexible couplings are available (sold separately).

Note

- When coupling the load to the motor, pay attention to the centering of the shafts, belt tension, parallelism of the pulleys, and so on. Securely tighten the coupling and pulley set screws.
- Be careful not to damage the output shaft or the bearings when installing a coupling or pulley to the motor's output shaft.
- Do not modify or machine the motor's output shaft. Doing so may damage the bearings and destroy the motor.
- When inserting a parallel key into the gear output shaft, do not apply excessive force by using a hammer or similar tool. Application of strong impact may damage the output shaft or bearings.

• Using a coupling

Align the centers of the motor's output shaft and load shaft in a straight line.

• Using a belt drive

Align the motor's output shaft and load shaft in parallel with each other, and position both pulleys so that the line connecting their centers is at a right angle to the shafts.

• Using a gear drive

Align the motor's output shaft and gear shaft in parallel with each other, and let the gears mesh at the center of the tooth widths.

• Connecting with a key (Geared motor)

With a geared motor, to connect a load to the gear output shaft having a key groove, first provide a key groove on the load and fix the load with the gear output shaft using the supplied key.

• Installing on the flange surface (Harmonic geared type)

With a harmonic geared type, a load can be installed directly to the gear using the load mounting holes provided on the flange surface.

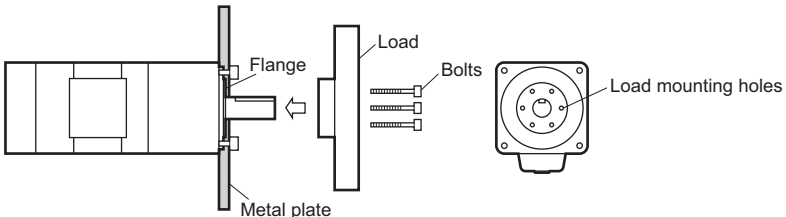

Unit model	Bolt size	Number of a bolts	Tightening torque [N·m (oz-in)]	Effective depth of thread [mm (in.)]
ASC46-H□	M3	6	1.4 (198)	5 (0.2)
ASC66-H□	M4	6	2.5 (350)	6 (0.24)

- Note**
- When installing a load on the flange surface, the load cannot be affixed using the key groove in the output shaft.
 - Design an appropriate installation layout so that the load will not contact the metal plate or bolts used for installing the motor.

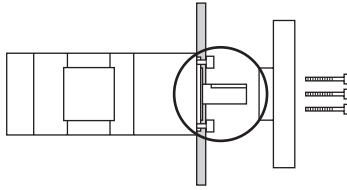

5.4 Permissible overhung load and permissible thrust load

The overhung load and thrust load on the motor's output shaft or gear output shaft must be kept within the permissible values listed below.

- Note** Failure due to fatigue may occur if the motor's bearings and output shaft are subject to repeated loading by an overhung or thrust load that is in excess of the permissible limit.

Frame size	Unit type	Permissible overhung load [N (lb.)]					Permissible thrust load [N (lb.)]
		Distance from the tip of motor's output shaft [mm (in.)]					
		0 (0)	5 (0.2)	10 (0.39)	15 (0.59)	20 (0.79)	
28 mm (1.1 in.)	ASC34-T□	15 (3.3)	17 (3.8)	20 (4.5)	23 (5.1)	—	10 (2.2)
	ASC34-N□	45 (10.1)	60 (13.5)	80 (18)	100 (22)	—	20 (4.5)
	ASC34-H□	140 (31)	160 (36)	200 (45)	240 (54)	—	100 (22)
	ASC34	25 (5.6)	34 (7.6)	52 (11.7)	—	—	0.15 (0.33)*
	ASC36						0.22 (0.48)*

Frame size	Unit type	Permissible overhung load [N (lb.)]					Permissible thrust load [N (lb.)]
		Distance from the tip of motor's output shaft [mm (in.)]					
		0 (0)	5 (0.2)	10 (0.39)	15 (0.59)	20 (0.79)	
42 mm (1.65 in.)	ASC46-T□	10 (2.2)	14 (3.1)	20 (4.5)	30 (6.7)	—	15 (3.3)
	ASC46-N□	100 (22)	120 (27)	150 (33)	190 (42)	—	100 (22)
	ASC46-H□	180 (40)	220 (49)	270 (60)	360 (81)	510 (114)	240 (54)
	ASC46	20 (4.5)	25 (5.6)	34 (7.6)	52 (11.7)	—	0.5 [0.6] (1.1 [1.3])*
60 mm (2.36 in.)	ASC66-T□	70 (15.7)	80 (18)	100 (22)	120 (27)	150 (33)	40 (9)
	ASC66-N5	200 (45)	220 (49)	250 (56)	280 (63)	320 (72)	100 (22)
	ASC66-N7.2 ASC66-N10	250 (56)	270 (60)	300 (67)	340 (76)	390 (87)	
	ASC66-N25 ASC66-N36 ASC66-N50	330 (74)	360 (81)	400 (90)	450 (101)	520 (117)	
	ASC66-H□	320 (72)	370 (83)	440 (99)	550 (123)	720 (162)	470 (105)
	ASC66	63 (14.1)	75 (16.8)	95 (21)	130 (29)	190 (42)	0.85 [1.1] (1.9 [2.4])*

- The square box in the unit type will contain a value representing the gear ratio.
- The figures indicated by * are the motor's mass [kg (lb.)]. The thrust load should not exceed the motor's dead mass.
- The figures in parenthesis [] are the values for the electromagnetic brake motor.

■ Permissible moment load of the harmonic geared type

When installing an arm or table on the flange surface, calculate the moment load using the formula below if the flange surface receives any eccentric load.

The moment load should not exceed the permissible value specified in the table.

Moment load: $M [N \cdot m (oz \cdot in)] = F \times L$

Unit model	Permissible moment load [N·m (oz-in)]
ASC46-H□	5.6 (790)
ASC66-H□	11.6 (1640)

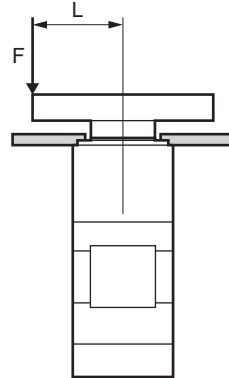

5.5 Installing the driver

■ Installation direction

Since the driver remains in operation even when the motor is at rest, and therefore generates a larger amount of heat than other control system equipment, provide ventilation near the driver.

Install the driver on a flat metal plate having excellent vibration resistance and heat conductivity.

Install the driver in vertical or horizontal orientation by securing it with two bolts (M3, not supplied) through the driver's mounting holes or mounting cutouts. Leave no gap between the driver and metal plate. Any other installation method will reduce the driver's ability to dissipate heat.

■ Installation method

There must be a clearance of at least 25 mm (0.98 in.) and 50 mm (1.97 in.) in the horizontal and vertical directions, respectively, between the driver and enclosure or other equipment.

When two or more drivers are to be installed side by side, provide 20 mm (0.79 in.) and 50 mm (1.97 in.) clearances in the horizontal and vertical directions, respectively.

Note

- Install the driver in an enclosure.
- Do not install any equipment that generates a large amount of heat near the driver.
- Check ventilation if the ambient temperature of the driver exceeds 40 °C (104 °F).

- Horizontal installation

- When using mounting holes

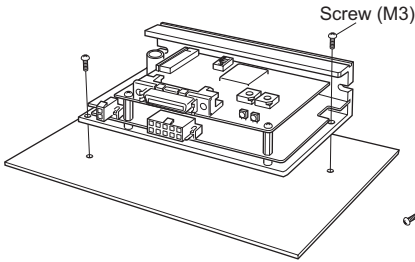

- When using mounting cutouts

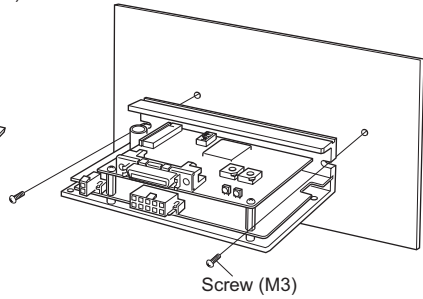

- Vertical installation

- When using mounting holes

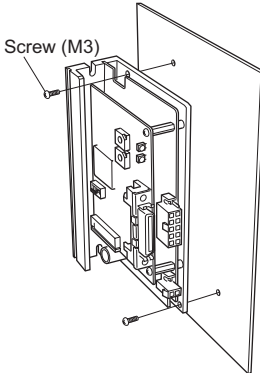

- When using mounting cutouts

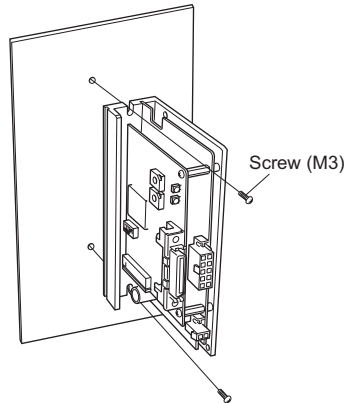

5.6 Installing and wiring in compliance with EMC Directive

■ Introduction

EMC Directive (89/336/EEC, 92/31/EEC)

The **αSTEP ASC** series has been designed and manufactured for incorporation in general industrial machinery. The EMC Directive requires that the equipment incorporating this product comply with these directives.

The installation and wiring method for the motor and driver are the basic methods that would effectively allow the customer's equipment to be compliant with the EMC Directive.

The compliance of the final machinery with the EMC Directive will depend on such factors as the configuration, wiring, layout and risk involved in the control-system equipment and electrical parts. It therefore must be verified through EMC measures by the customer of the machinery.

Applicable standards

EMI	Emission Tests Radiated Emission Test	EN 61000-6-4 EN 55011
EMS	Immunity Tests Radiation Field Immunity Test Electrostatic Discharge Immunity Test Fast Transient / Burst Immunity Test Conductive Noise Immunity Test	EN 61000-6-2 IEC 61000-4-3 IEC 61000-4-2 IEC 61000-4-4 IEC 61000-4-6

■ Installing and wiring in compliance with EMC Directive

Effective measures must be taken against the EMI that the ***αSTEP ASC*** series may give to adjacent control-system equipment, as well as the EMS of the ***αSTEP ASC*** series itself, in order to prevent a serious functional impediment in the machinery. The use of the following installation and wiring methods will enable the ***αSTEP ASC*** series to be compliant with the EMC Directive (the aforementioned compliance standards).

- **About power supply**

The ***αSTEP ASC*** series products are of the DC power supply input specification. Use a DC power supply (such as a switching power supply) that is optimally compliant with the EMC Directive. If a transformer is used in the power supply, be sure to connect a mains filter to the input side of the transformer.

- **Connecting mains filter for power supply line**

Install a mains filter on the input side of the DC power supply in order to prevent the noise generated within the driver from propagating outside via the DC power supply line. For mains filters, use 10ESK1 (Tyco Electronics CORCOM), ZAG2210-11S (TDK Corporation), or an equivalent.

Install the mains filter as close to the AC input terminal of DC power supply as possible, and use cable clamps and other means to secure the input and output cables (AWG18: 0.75 mm² or more) firmly to the surface of the enclosure. Connect the ground terminal of the mains filter to the grounding point, using as thick and short a wire as possible. Do not place the AC input cable (AWG18: 0.75 mm² or more) parallel with the mains filter output cable (AWG18: 0.75 mm² or more). Parallel placement will reduce mains filter effectiveness if the enclosure's internal noise is directly coupled to the power supply cable by means of stray capacitance.

- **Power supply for electromagnetic brake (for electromagnetic brake motor only)**

If a DC power supply is required for the use of the electromagnetic brake, use a DC power supply that complies with the EMC directive. Use a shielded cable for wiring, and keep the wiring and grounding as short as possible. Refer to page 23 for details on how to ground the shielded cable.

- **How to ground**

The cable used to ground the driver, motor and mains filter must be as thick and short as possible so that no potential difference is generated. Choose a large, thick and uniformly conductive surface for the grounding point.

- **Wiring the power supply cable and signal cable**

Use a shielded cable of AWG18 (0.75 mm^2) or more in diameter for the driver power supply cable. Use a shielded cable of AWG28 (0.08 mm^2) or more in diameter for the driver signal cable, and keep it as short as possible. Contact the nearest sales office for a driver cable (sold separately). Refer to page 51 for details.

To ground a shielded cable, use a metal clamp or similar device that will maintain contact with the entire circumference of the shielded cable. Attach a cable clamp as close to the end of the cable as possible, and connect it as shown in the figure.

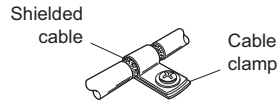

- **Notes about installation and wiring**

- Connect the motor, driver and other peripheral control equipment directly to the grounding point so as to prevent a potential difference from developing between grounds.
- When relays or electromagnetic switches are used together with the system, use mains filters and CR circuits to suppress surges generated by them.
- Keep cables as short as possible without coiling and bundling extra lengths.
- Place the power cables such as the motor and power supply cables as far apart [100 to 200 mm (3.94 to 7.87 in.)] as possible from the signal cables. If they have to cross, cross them at a right angle. Place the AC input cable and output cable of a mains filter separately from each other.
- If an extension cable is required between the motor and driver, it is recommended that an optional extension cable (sold separately) be used, since the EMC measures are conducted using the Oriental Motor extension cable.

- Example of DC power supply input specification installation and wiring

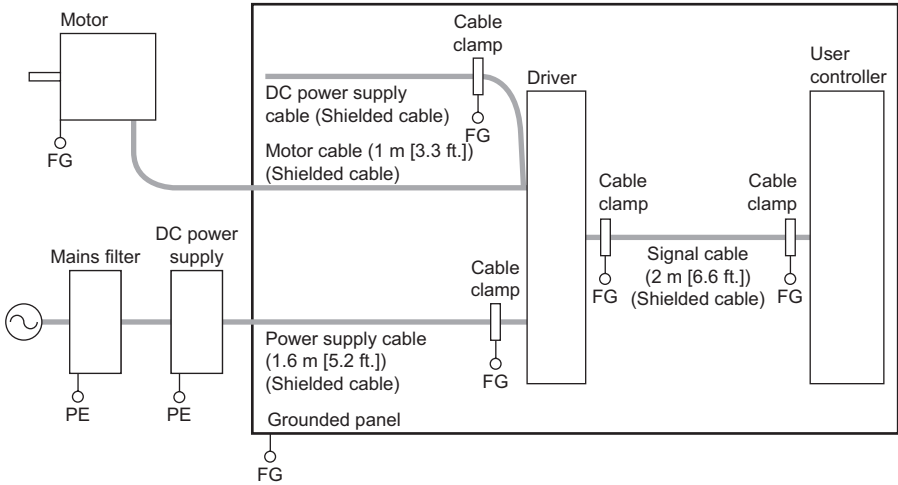

■ Precautions about static electricity

Static electricity may cause the driver to malfunction or suffer damage. Be careful when handling the driver with the power on.

Always use an insulated screwdriver to adjust the driver's built-in motor current switch.

Note | Do not come close to or touch the driver while the power is on.

6 Connection

This section covers the methods and examples of connecting and grounding the driver, motor, power and controller, as well as the control input/output.

6.1 Connection example

■ In the case of current sourcing inputs and current sinking outputs

● Connection of 5 VDC

Either 5 or 24 VDC is selected as a signal voltage for the C.OFF input, ×10 input and ACL input.

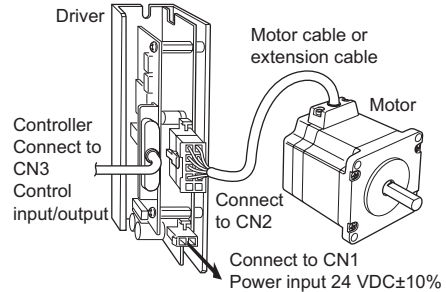

Note

Be certain the control input/output cable that connects the driver and controller is as short as possible. The maximum input frequency will decrease as the cable length increases.

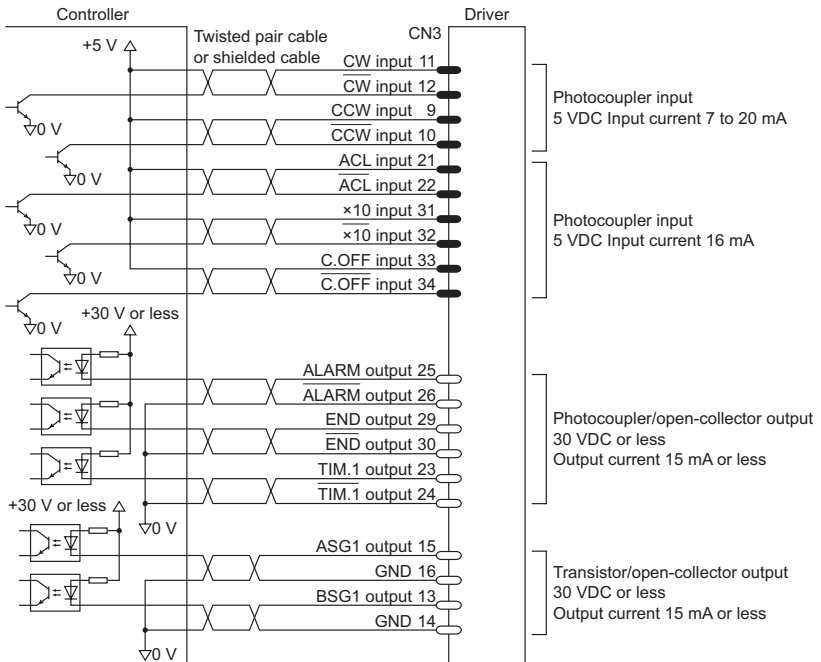

- Connection of 24 VDC

Either 5 or 24 VDC is selected as a signal voltage for the C.OFF input, ×10 input and ACL input.

Note The CW and CCW inputs are of the 5 VDC input specification. If V_0 exceeds 5 V, connect external resistor R_0 .
 Example) When V_0 is 24 VDC R_0 : 1.5 to 2.2 k Ω , 0.5 W or more.

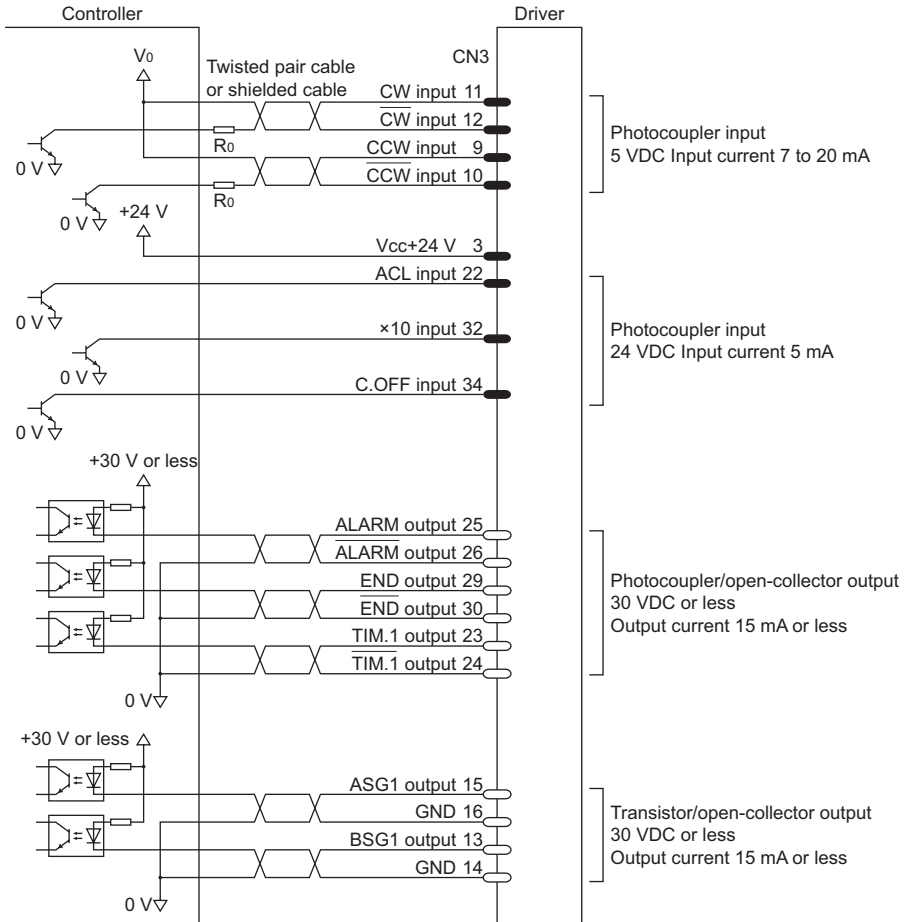

■ In the case of current sinking inputs and current sourcing outputs

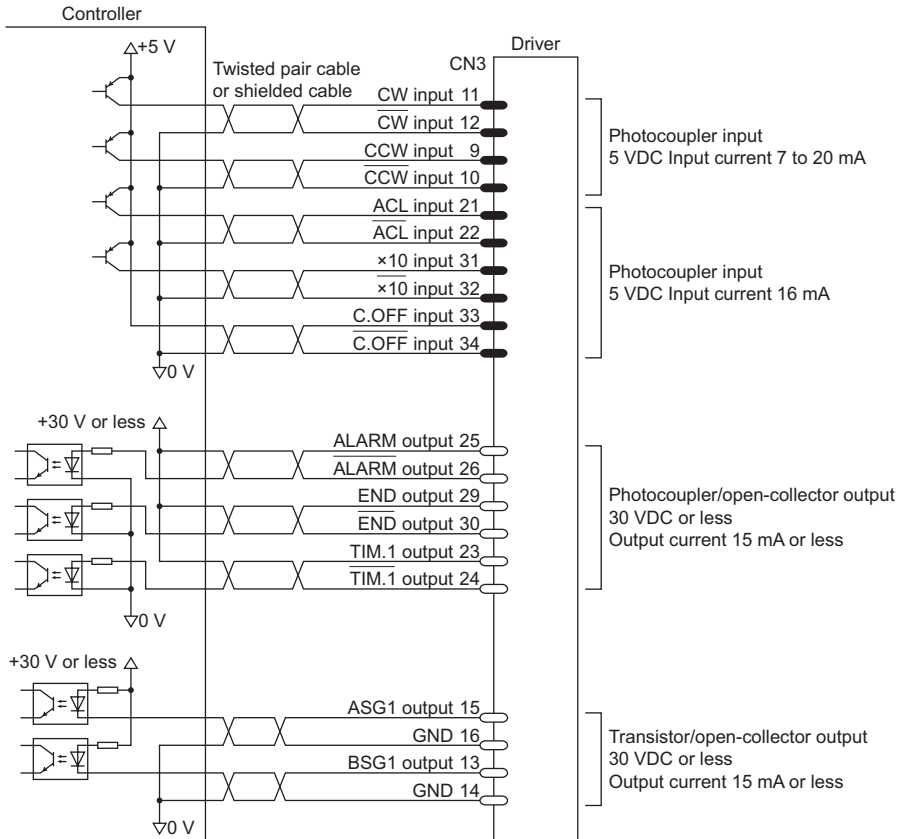

Note

- GND of ASG1, BSG1 is common.
- The output type of these signals is current sinking outputs. See page 37 for the wiring.

6.2 Connecting to the power supply

Use a power supply capable of supplying the power/current capacity as shown below.

Unit model	ASC34□□	ASC36□□	ASC46□□	ASC66□□
Input power supply voltage	24 VDC±10%			
Current capacity	1 A or more	1.1 A or more	1.7 A or more	3.7 A or more

* Each of the square boxes will contain a numerical or alphabetical character representing the availability of the electromagnetic brake, power supply input or gear type.

■ Crimping the crimp terminal

Securely crimp the terminal to the power supply connector using the crimping tool specified by the connector manufacturer. We do not provide crimping tools. Use a power supply cable of AWG20 (0.5 mm²) to AWG18 (0.75 mm²) in diameter.

When connecting the cable, be careful regarding the polarity of the power supply.

Incorrect power supply polarity could damage the driver.

Product number of the specified crimping tool manufactured by Molex:

57026-5000 (for UL 1007) or 57027-5000 (for UL 1015)

Note

- Have the connector plugged in securely. Insecure connection may cause malfunction or damage to the motor or driver.
- When pulling out a connector, pull it out by slightly expanding the latch part of the connectors using a precision screwdriver.
- Do not run the driver's power supply cable through a conduit containing other power supply lines or motor cables.
- Always wait at least 5 sec. after switching off the power supply before switching it back on again or connecting/disconnecting the motor cables connector.

■ Connector configuration

Power supply connector

Connector	Pin No.	Signal	Description
CN1	1	+24 V	24 VDC±10%
	2	GND	

Securely insert the crimp terminal into the power supply connector so that the terminal will not bend or be out of position. Failure to do so may damage the motor and driver.

■ Connecting the power supply connector

Plug of the power supply connector into the driver's power supply connector (CN1).

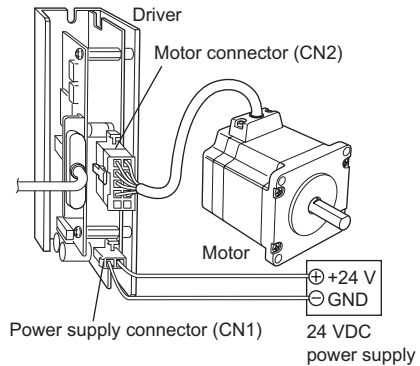

6.3 Connecting the standard type motor

Plug the connector of the motor cable into the driver's motor connector (CN2). Use an optional extension cable (sold separately) to extend the distance between the motor and driver. Refer to page 51 of 11 "Options (Sold separately)" for the extension cable.

Note

- Make the connector is plugged in securely. Insecure connection may cause malfunction or damage to the motor or driver.
- To disconnect the plug, pull the plug while using your fingers to press the latches on the plug.
- When installing the motor to a moving part, use an optional flexible extension cable offering excellent flexibility (sold separately). Refer to page 51 of 11 "Options (Sold separately)" for more information regarding the flexible extension cables.

6.4 Connecting the electromagnetic brake motor

■ ASM46

Connect the motor cable or an optional extension cable (for a standard motor) into the driver's motor connector (CN2).

■ ASM66

Connect an optional extension cable for electromagnetic brake type into the driver's motor connector (CN2).

6.5 Connecting the power supply for the electromagnetic brake

The electromagnetic brake operates via the ON/OFF state of its DC power supply. Provide a dedicated DC power supply of 24 VDC±5%, 0.3 A or more (**ASC46**: 0.1 A or more) for the electromagnetic brake. When connecting the electromagnetic brake to the DC power supply, use a shielded cable of AWG24 (0.2 mm²) or more, and keep it as short as possible.

■ ASM46

Connect the two lead wires [600 mm (23.6 in.)] from the motor to the DC power supply.

1. Connect the red lead wire to the +24 V terminal of the DC power supply.
2. Connect the black lead wire to the GND terminal of the DC power supply.
3. Connect the varistor (provided) in parallel across the +24 V and GND terminals of the DC power supply.

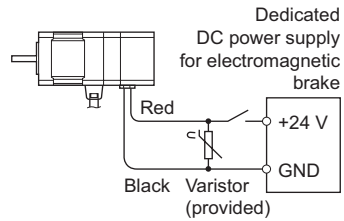

■ ASM66

Use an optional extension cable for electromagnetic brake type or flexible extension cable for electromagnetic brake type. Connect the two lead wires [40 mm (1.6 in.)] from the driver's connector side to the DC power supply.

1. Connect the lead wire (extension cable: orange/black, flexible extension cable: orange) to the +24 V terminal of the DC power supply.
2. Connect the gray lead wire to the GND terminal of the DC power supply.
3. Connect the varistor (provided) in parallel across the +24 V and GND terminals of the DC power supply.

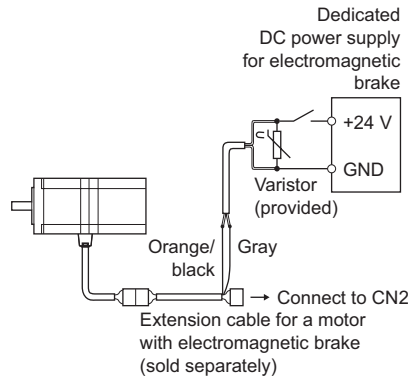

Note

- Applying a voltage over the specification will increase the temperature rise in the electromagnetic brake and may damage the motor. Conversely, insufficient voltage may prevent the brake from releasing.
- Be sure to connect the varistor (non-polarized) to protect the switch contacts and prevent noise.
- Connecting the lead wires in reversed polarity will not properly operate the electromagnetic brake. The lead wires for the electromagnetic brake are polarized.
- Provide separate power supplies for the control input/output and the electromagnetic brake.

6.6 Connecting the control input/output

■ Assembling the control input/output connector

Solder the control input/output cable (AWG28: 0.08 mm² or more) to the connector (36 pins). Assemble the connector and cover with the supplied screws. For the pin assignments, refer to page 32.

We provide optional driver cable allowing one-touch connection with a driver, as well as connector-terminal block conversion unit. Refer to page 51 for details.

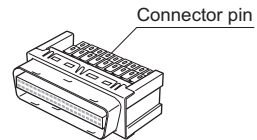

- Assembling the connector and the case

1. Attach the supplied screws (two pcs.) to the case and insert the connector with the control input/output cable soldered to it. Adjust the cable clamp to its correct position.

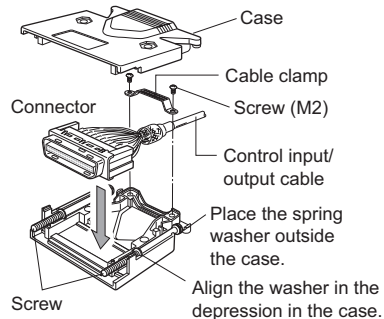

2. Attach the other cover and clamp both connector cases together with screws and nuts. Tightening torque: 0.5 to 0.55 N·m (71 to 78 oz-in)

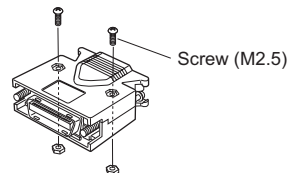

■ Connecting control input/output connector

Insert the control input/output connector into the control input/output connector CN3 on the driver side, and tighten the screw with a flat blade-parallel tip type screwdriver.

Tightening torque: 0.3 to 0.35 N·m
(42 to 49 oz-in)

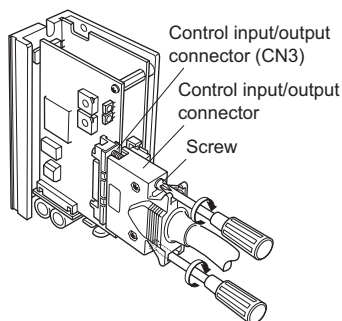

Connector pin assignments (Viewed from the soldering side)

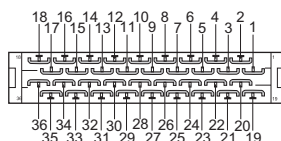

● Connector pin functions

Pin No.	Signal	Description	Direction	Pin No.	Signal	Description	Direction
1	—	Not used	—	19	—	Not used	—
2	GND	External power supply	Input	20	—	Not used	—
3	Vcc+24 V			21	ACL	Alarm clear	Input
4	—	Not used	—	22	$\overline{\text{ACL}}$		
5	—	Not used	—	23	TIM.1	Timing Open-collector	Output
6	—	Not used	—	24	$\overline{\text{TIM.1}}$		
7	—	Not used	—	25	ALARM	Alarm	Output
8	—	Not used	—	26	$\overline{\text{ALARM}}$		
9	CCW(DIR.)	CCW pulse (ON: CW, OFF: CCW)	Input	27	—	Not used	—
10	$\overline{\text{CCW(DIR.)}}$			28	—	Not used	—
11	CW(PLS)	CW pulse (Pulse)	Input	29	END	Positioning complete	Output
12	$\overline{\text{CW(PLS)}}$			30	$\overline{\text{END}}$		
13	BSG1	B-phase pulse output Open-collector	Output	31	$\times 10$	Resolution select	Input
14	GND			32	$\overline{\times 10}$		
15	ASG1	A-phase pulse output Open-collector	Output	33	C.OFF	All Windings Off	Input
16	GND			34	$\overline{\text{C.OFF}}$		
17	—	Not used	—	35	—	Not used	—
18	—	Not used	—	36	—	Not used	—

Note

The functions shown in parentheses are enabled when “1P: 1-Pulse Input Mode” is selected through the pulse input mode select switch.

6.7 About controll input/output

■ Input signals

All input signals of the driver are photocoupler inputs.

The signal state represents the “ON: Carrying current” or “OFF: Not carrying current” state of the internal photocoupler rather than the voltage level of the signal.

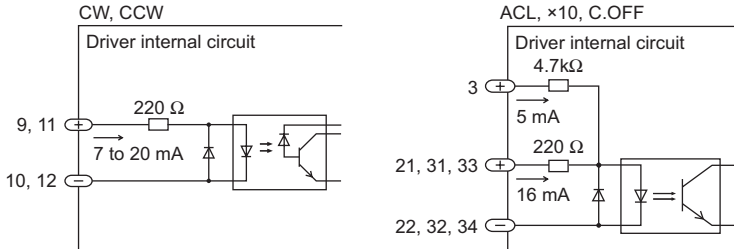

Note

- If no pulse is to be input, be sure to keep the photocoupler in “OFF” state. Do not input a CW pulse and CCW pulse simultaneously. If a pulse is input while the other photocoupler is in the “ON” state, the motor will not operate properly.
 - The direction of rotation is defined as the rotation direction of the motor shaft. The output shaft of the **TH** geared typed motors with ratios of 20:1 and 30:1, as well as all ratios of the harmonic geared type motors, rotate in the opposite direction of the motor shaft.
 - The factory setting of the pulse input mode depends on the destination country. Check the pulse input mode setting in accordance with the pulse mode in the controller used.
- CW input and CCW input

With this driver either 2-pulse input mode or 1-pulse input mode may be selected in accordance with the controller used. Refer to page 42 for details on how to set the pulse input mode.

ALARM output is in the “OFF” state immediately after the driver power is turned on. Check to see that ALARM output has been turned from “OFF” to “ON” before inputting pulse signals.

For the electromagnetic brake motor, wait at least 0.1 second after releasing the electromagnetic brake, then input pulse signals. When an electromagnetic brake motor is used, also refer to “Operating the electromagnetic brake” on page 39.

2-pulse input mode

Connect the CW pulse and CCW pulse of the controller to pin No.12, “CW input,” and pin No. 10, “CCW input,” respectively.

1. When the CW pulse input changes from the “OFF” state to “ON” state, the motor will rotate one step in the CW direction.
2. When the CCW pulse input changes from the “OFF” state to “ON” state, the motor will rotate one step in the CCW direction.

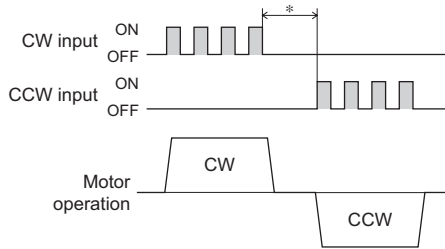

* The minimum interval time needed for switching the direction of rotation will vary, depending on the operating speed and size of the load. Do not shorten the interval time any more than is necessary.

Set the input pulse voltage to the CW and CCW pulse inputs at 5 VDC. If the voltage exceeds 5 VDC, insert an external resistor to limit the input current to nearly 10 mA.

$$R = \frac{V - 1.5}{10 \text{ mA}} - 220 [\Omega]$$

R: external resistor
V: Pulse voltage

1-pulse input mode

In 1-pulse input mode, the pin functions will be as follows: pin no. 11, “PLS input”; pin no. 12, “PLS input”; pin no. 9, “DIR. input”; and pin no. 10, “DIR. input.” Connect the pulse signal of the controller to pin No.12, and the rotating direction signal to pin No.10, respectively.

1. When the DIR. input is “ON,” a rise of the “PLS input” from “OFF” to “ON” will rotate the motor one step in the CW direction.
2. When the DIR. input is “OFF,” a rise of the “PLS pulse input” from “OFF” to “ON” will rotate the motor one step in the CCW direction.

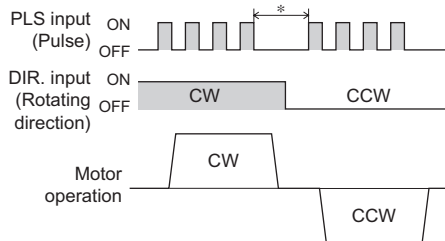

* The minimum interval time needed for switching the direction of rotation will vary, depending on the operating speed and size of the load. Do not shorten the interval time any more than is necessary.

The voltage of pulse and rotation direction input to the PLS input and DIR. input shall be 5 VDC. If the voltage exceeds 5 VDC, connect an external resistor to limit the input current to nearly 10 mA.

$$R = \frac{V - 1.5}{10 \text{ mA}} - 220 \text{ } [\Omega]$$

R: external resistor
V: Pulse voltage

Use an input-pulse signal with a waveform having a sharp rise and fall, as shown in the figure. The figure shows the voltage levels of pulse signals.

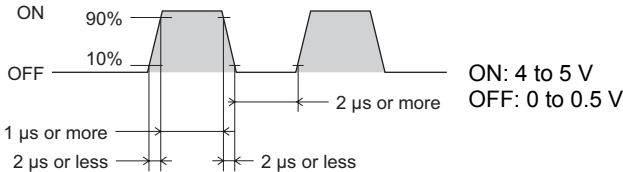

• C.OFF (All windings off) input

Use the signal only when the motor's output shaft must be rotated manually for position adjustment.

1. When the C.OFF input is turned "ON," the driver will shut off the output current and the motor will lose its excitation holding torque. This, however, will allow you to adjust the load position manually.
2. When the C.OFF input is turned "OFF," the driver will turn the output current to "ON" again and the motor's excitation holding torque will be restored. The C.OFF input must be "OFF" when operating the motor.

Note

- Normally, keep the C.OFF input in the "OFF" state or leave it disconnected.
- Turning the C.OFF input to "ON" resets the deviation counter in the driver.

- **×10 (Resolution select) input**

Selects and switches to 10 times either of the resolution “500: 0.72°/pulse” or “1000: 0.36°/ pulse” that has been selected with the resolution select switch.

For instance, if “1000: 0.36°/pulse” has been selected, this signal can switch between the 0.36° step rotation and 0.036° step rotation. Refer to page 41 for the selection of the resolution select switch.

1. Turning the ×10 input to “ON” will select and switch to “×10 resolution.”
2. Turning the ×10 input to “OFF” will select and switch to “×1 resolution.”

Note Be sure to set the resolution select switch to “×1” when “×10 input” is used. If the switch is set to “×10,” the resolution will remain at 10 times, regardless of the “ON” or “OFF” resolution select input.

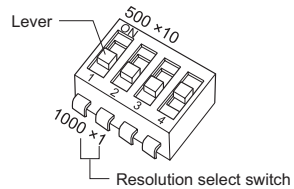

- **ACL (Alarm clear) input**

The input clears the ALARM output issued when a protective function has been triggered. The ALARM output remains “ON” when the driver is operating normally, then turns “OFF” when a protective function is triggered. For details, refer to “ALARM output” on page 37 and 8 “Protective functions” on page 45.

Setting the ACL input in the ON state clears the ALARM output. To cancel the ALARM output, be sure to remove the cause of the problem that has triggered the protective function before turning the power back on.

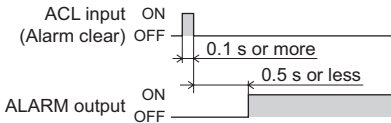

Note

- Turning the power back on will clear the ALARM output. To cancel the ALARM output, be sure to remove the cause of the problem that has triggered the protective function before turning the power back on. After the power has been shut off, wait at least 5 seconds before turning the power back on.
- The overcurrent protection, EEPROM data error and system error cannot be cleared using the ACL input. Clear these errors by cycling the power. If the problem persists, please contact the nearest office.

■ Output signals

Driver output signals are photocoupler/ open-collector output (ALARM, END and TIM.1) and transistor open-collector output (ASG1 and BSG1). The signal state represents the “ON: Carrying current” or “OFF: Not carrying current” state of the internal photocoupler rather than the voltage level of the signal.

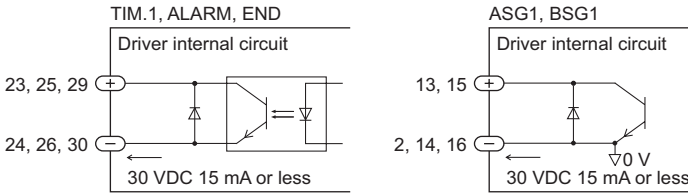

● ALARM output

ALARM output remains “ON” when the driver is operating normally, then turns “OFF” when a protective function is triggered. Detect this ALARM output on the controller side and cancel the command to operate the motor thereafter.

Error detection by the driver, such as overload and overcurrent during motor operation, turns the ALARM output “OFF,” blinks the ALARM LED on the driver, and simultaneously shuts off the motor current to stop motor operation. Count the number of the ALARM LED blinks to identify the particular protective function that has been triggered. For details, refer to 8 “Protective functions” on page 45.

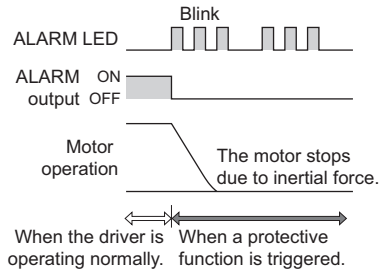

● END (Positioning complete) output

END output turns “ON” when motor movement is complete.

Conditions for the issuance of END output are as follows: END output is issued when the pulse speed is 500 Hz or less, and the rotor has positioned within $\pm 1.8^\circ$ of the commanded position.

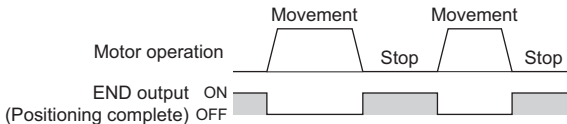

Note

The timing of the END output turning “ON” after the pulse stops will vary, depending on the conditions of the load, the pulse input, and the speed-filter setting.

- **TIM.1 (Timing) output**

TIM.1 output turns “ON” whenever the motor’s output shaft rotates 7.2°.

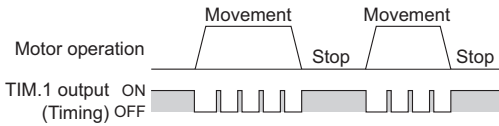

Note | If TIM.1 output is to be detected, set the pulse speed at 500 Hz or less. Use the ×10 input to switch the resolution only when TIM.1 output is in the “ON” state and the motor stops. If the resolution is switched under any other conditions, TIM.1 output may not turn “ON” even when the output shaft has rotated 7.2°.

- **ASG1 output and BSG1 output**

ASG1 and BSG1 outputs are available in transistor open-collector output. The output-pulse resolution will be the same as the motor resolution at the time power is supplied to the driver (as set by the resolution select switch). Counting the ASG1 output pulses allows the motor position to be monitored.

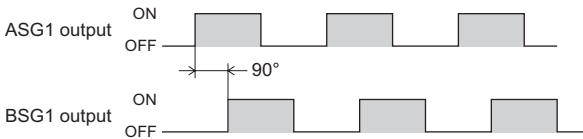

ASG1 output: Outputs pulse while the motor operates.

BSG1 output: Detects the direction of motor rotation. It has a 90° phase difference with regard to ASG1 output. The level of BSG1 output at the rise time of ASG1 output indicates the direction of motor rotation.

Note | The pulse-output delays behind motor rotation by up to 1 ms. The output may be used to verify the motor’s stop position.

■ Operating the electromagnetic brake

Operate the electromagnetic brake as follows:

1. ALARM output is in the “OFF” state immediately after the driver power is turned on. Check to see that ALARM output has been reset (turned from OFF to ON), then turn on the electromagnetic brake.
2. Before inputting pulse signals to operate the motor, set the motor in the ready state by “releasing” the electromagnetic brake.
3. To allow the electromagnetic brake to “hold” the load after the motor has completed its operation, turn the electromagnetic brake off only after verifying that END (positioning complete) output has turned from “OFF” to “ON.”

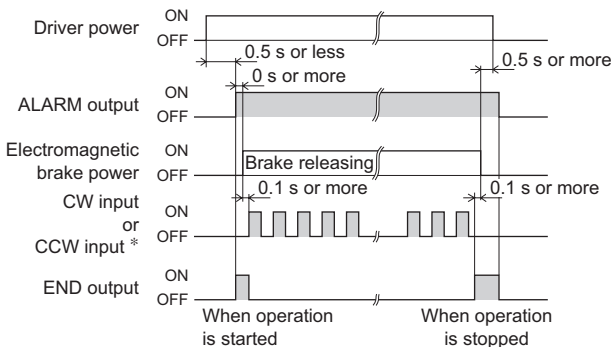

* CCW input is enabled when 2-pulse input mode is selected

Note

To hold the load in position, apply the electromagnetic brake only after the motor has stopped. Do not use the brake to bring the moving motor to a halt. Repeated braking for such a purpose will wear the brake hub excessively, causing a decrease in its ability to hold.

● About providing for ALARM output

When the driver-protection function is triggered, the motor stops as the current is turned off. The motor loses its holding ability, which in a vertical-travel application may cause the load to fall. The user must set a controller sequence that will cut off the power to the electromagnetic brake and hold the load in position upon detecting an “OFF” ALARM output.

6.8 Timing chart

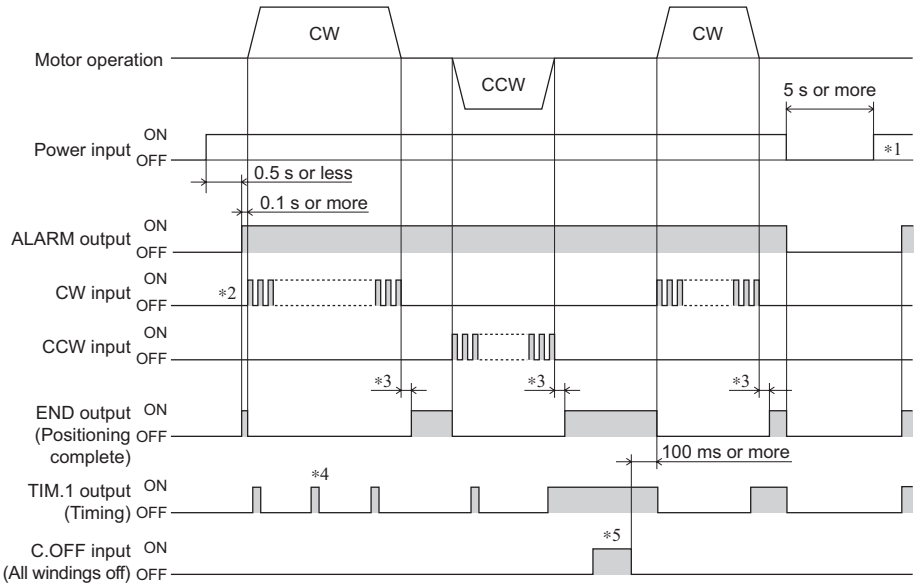

- *1 After the power has been shut off, wait at least 5 seconds before turning the power back on.
- *2 To input the CW or CCW signal pulse, wait at least 0.1 second after clearing the ALARM output.
- *3 The turning of END output to "ON" does not necessarily mean the motor has stopped. Provide enough of a time delay for a halt, which will vary, depending on the acceleration/deceleration rates and load condition.
- *4 Detect TIM.1 output only at a pulse speed of 500 Hz or less. No accurate detection is possible at a speed over 500 Hz.
- *5 Turning C.OFF input "ON" shuts off the motor current, at which time the motor loses its holding ability. It also clears the value on the deviation counter.

7 Setting

This section covers the selection and settings of driver functions.

7.1 Resolution

Use the resolution select switch “1000/500” and “ $\times 1/\times 10$ ” to set the motor resolution.

Factory settings

[1000]: 1000 P/R (0.36°/pulse)

[$\times 1$]: Multiplier 1

A total of four resolution levels may be selected, with $\times 10$ input “CN3 Pin No.31, 32” used to switch between 1000 and 10000 and between 500 and 5000.

Refer to page 36 for the use of $\times 10$ input.

Refer to the following table for details of the relationship between the setting of the resolution select switch and resolution of the geared output shaft in the geared type.

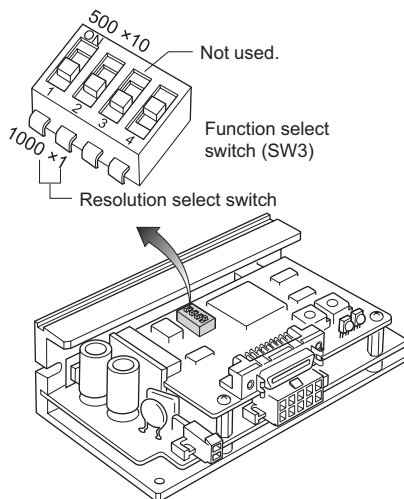

Note

- Be sure to shut off the power before using the resolution select switch. The new resolution takes effect when the power is turned on again.
- Be sure to set the resolution select switch to “ $\times 1$ ” when “ $\times 10$ ” input is used. If the switch is set to “ $\times 10$,” “ $\times 10$ ” input becomes invalid.

Gear ratio	Resolution			
	1000P/R	10000P/R	500P/R	5000P/R
3.6:1	0.1°/Pulse	0.01°/Pulse	0.2°/Pulse	0.02°/Pulse
5:1	0.072°/Pulse	0.0072°/Pulse	0.144°/Pulse	0.0144°/Pulse
7.2:1	0.05°/Pulse	0.005°/Pulse	0.1°/Pulse	0.01°/Pulse
10:1	0.036°/Pulse	0.0036°/Pulse	0.072°/Pulse	0.0072°/Pulse
20:1	0.018°/Pulse	0.0018°/Pulse	0.036°/Pulse	0.0036°/Pulse
25:1	0.0144°/Pulse	0.00144°/Pulse	0.0288°/Pulse	0.00288°/Pulse
30:1	0.012°/Pulse	0.0012°/Pulse	0.024°/Pulse	0.0024°/Pulse
36:1	0.01°/Pulse	0.001°/Pulse	0.02°/Pulse	0.002°/Pulse
50:1	0.0072°/Pulse	0.00072°/Pulse	0.0144°/Pulse	0.00144°/Pulse
100:1	0.0036°/Pulse	0.00036°/Pulse	0.0072°/Pulse	0.00072°/Pulse

7.2 Pulse input modes

Either the 2-pulse or 1-pulse input mode may be selected in accordance with the controller used.

When the motor is to be controlled through 2-pulse signal input via the CW pulse signal and CCW pulse signal, set the pulse input mode select switch to “2P.”

When the motor is to be controlled through the PLS (pulse) and the DIR. (rotating direction) input, set the pulse input mode select switch to “1P.”

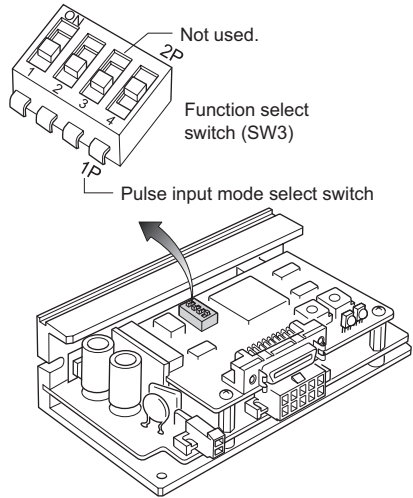

Note

- Be sure to shut off the power before using the pulse input mode select switch. The new pulse mode takes effect when the power is turned on again.
- The factory setting of the pulse input mode depends on the destination country. Check the pulse input mode setting in accordance with the pulse mode in the controller used.

7.3 Operating current

Use the operating-current adjustment switch “SW1” to set the motor’s operating current. Set the operating current as a product of the maximum driver output current “F,” which is 100%, multiplied by the operating current percentage corresponding to the given dial. The switch provides a selection of 16 levels ranging between “0” to “F.” If there is extra torque, the current may be set to a lower level in order to suppress increases in motor temperature.

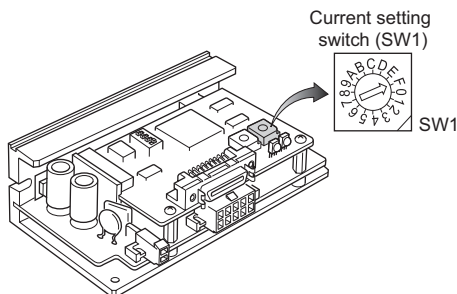

Factory setting

[F]: Driver’s maximum output-current value

The dial settings and corresponding levels of operating current rates are as follows:

Dial setting	Operating current rate [%]	Dial setting	Operating current rate [%]
0	6	8	56
1	13	9	63
2	19	A	69
3	25	B	75
4	31	C	81
5	38	D	88
6	44	E	94
7	50	F	100

Note

An excessively low operating current level may cause a problem when starting the motor or holding the load in position. Do not reduce the current any more than is necessary.

7.4 Speed filter

Use the speed-filter select switch “SW2” to select the filter time constant that determines the motor’s response to pulse input. The switch provides a selection of 16 levels ranging between “0” to “F.” When a larger value is selected, it will reduce shock when the motor is started and stopped, and will minimize low-speed vibration. The greater the filter time constant, the smoother the motor movement becomes. However, command synchronicity will decrease. Select an optimal value to fit the load and application.

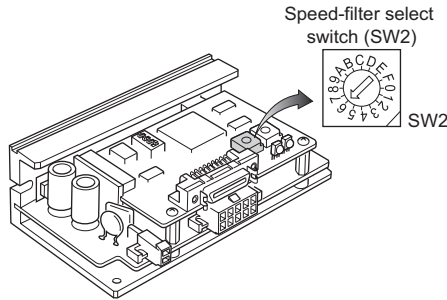

Factory setting

[6]: 1.20 ms

The dial settings and corresponding levels of filter time constants are as follows:

Dial setting	Filter time [ms]	Dial setting	Filter time [ms]
0	None	8	2.70
1	0.12	9	4.10
2	0.16	A	8.20
3	0.27	B	12.0
4	0.41	C	16.0
5	0.82	D	27.0
6	1.20	E	41.0
7	1.60	F	82.0

When the speed-filter select switch is set to [0]

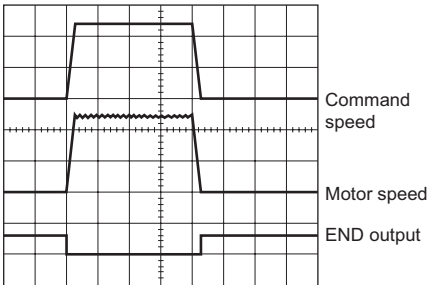

When the speed-filter select switch is set to [E]

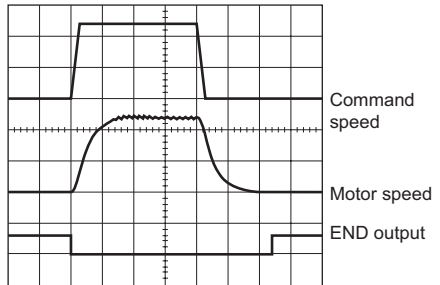

8 Protective functions

This section covers the driver-protection functions and methods used to clear the triggered function.

8.1 Descriptions of protective functions and numbers of LED blinks

The driver is provided with functions that protect the driver from improper power supply or motor cable connections, and the occurrence of operating errors.

When a protective function is triggered, the ALARM LED on the front panel blinks, ALARM output turns OFF, and simultaneously the motor current is shut off in order to stop the motor. ALARM output remains “ON” when the driver is operating normally, then turns “OFF” when a protective function is triggered. For details, refer to “ALARM output” on page 37.

ALARM LED blinking cycle (example: for overvoltage protection)

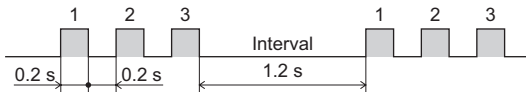

The number of ALARM LED blinks varies according to the nature of the triggered protective function, thereby facilitating action and recovery from the abnormal conditions causing the function to be triggered.

The table below gives descriptions of protective functions and their corresponding numbers of blinks.

Number of ALARM LED Blinks	Protective function	Conditions
2	Overload protection	When a load exceeding the maximum torque is applied to the motor for five seconds or more.
3	Overvoltage protection	When the voltage on the primary side of the driver inverter has exceeded the permissible value.
4	Speed error protection	When the motor has not normally followed up on pulse input.
6	Overspeed	When the motor shaft speed exceeds 5000 r/min.
7	EEPROM data error	When the motor parameter in the driver is damaged.
8	Sensor error	When power turns on without the connection of a motor cable to the driver.
ALARM LED turns on.	System error	When the driver is out of order.

8.2 How to clear a protective function

When a driver-protection function is triggered, turning the ALARM output OFF by employing either of the following methods may clear ALARM output (return to “ON”):

- Give a one-shot ACL (Alarm clear) input to clear the ALARM output.
- Turn the power back on.

Note

- To clear the ALARM output, be sure to remove the cause of the problem that has triggered the protective function before either giving a one-shot ACL input or turning the power back on. After turning off the power, wait at least 5 seconds before turning the power back on.
- The overcurrent protection, EEPROM data error and system error cannot be cleared using the ACL input. Clear these errors by cycling the power. If the problem persists, please contact the nearest office.

9 Inspection

It is recommended that periodic inspections be conducted for the items listed below after each operation of the motor. If an abnormal condition is noted, discontinue any use and contact your nearest office.

■ During inspection

- Are any of the motor mounting screws loose?
- Check for any unusual noises in the motor's bearings (ball bearings) or other moving parts.
- Are there any scratches, signs of stress or loose driver connections in the motor cable?
- Are the motor's output shaft (or gear output shaft) and load shaft out of alignment?
- Check for a blocked opening of the driver case.
- Are any of the driver mounting screws loose?
- Are there any strange smells or other abnormalities at the driver?

Note

The driver uses semiconductor elements, so be extremely careful when handling them. Static electricity may damage the driver.

10 Troubleshooting and remedial actions

During motor operation, the motor or driver may fail to function properly due to an improper speed setting or wiring. When the motor cannot be operated correctly, refer to the contents provided in this section and take appropriate action. If the problem persists, contact your nearest office.

■ If ALARM LED is not blinking

If the motor does not operate properly even though the ALARM LED is not blinking, refer to the table below:

Phenomenon	Possible cause	Remedial action
<ul style="list-style-type: none"> The motor is not excited. The motor can be turned with the hands. 	C.OFF input is "ON."	Turn the C.OFF input to "OFF" and confirm that the motor is excited.
The motor does not run.	Bad connection for CW or CCW input.	<ul style="list-style-type: none"> Check the connections of the controller and driver. Review the specifications (voltage and width) for the input pulse.
	In 2-pulse input mode, the CW and CCW pulse inputs are both "ON" at the same time.	Input the pulse signal either to the CW or CCW input. Make sure the terminal with no input is set to "OFF."
	In 1-pulse input mode, the pulse signal is connected to the DIR. input.	Connect the pulse signal to the PLS input.
	Electromagnetic brake is holding (electromagnetic brake motor only).	Release the electromagnetic brake by turning the power on.
The motor rotates in the direction opposite that which is specified.	When 2-pulse input mode is selected, the CW and CCW pulse inputs are connected in reverse.	Connect the CW pulse input to the CW pulse input and CCW pulse input to CCW pulse input.
	When 1-pulse input mode is selected, the rotating direction input is set in reverse.	Set to "ON" when setting the CW direction or "OFF" when setting the CCW direction.

Phenomenon	Possible cause	Remedial action
The geared output shaft rotates in the direction opposite motor rotation.	A geared type is used whose rotating direction is opposite that of the motor shaft.	<ul style="list-style-type: none"> • TH geared type rotates in the direction opposite motor rotation at gear ratios of 20:1 and 30:1. • All harmonic geared types rotate in the direction opposite motor rotation.
Motor operation is unstable.	Bad connection of the pulse signal line.	<ul style="list-style-type: none"> • Check the connections of the controller and driver. • Review the specifications (voltage and width) for input pulse.
Vibration is great.	Small load.	Reduce the current by adjusting the driver's current adjustment switch. If the motor's output torque is too great for the load, vibration will increase.
The electromagnetic brake does not hold.	The electromagnetic brake is turned on.	To use an electromagnetic brake to hold the load in position after the motor has stopped, turn off the electromagnetic brake.
The TIM.1 output does not turn "ON."	The "×10" input is turned "OFF" during operation.	When the "×10" input is turned "OFF," the TIM.1 output may not turn "ON."

■ If the ALARM LED is blinking

If the ALARM LED is blinking, count the number of blinks and refer to the table below: The ALARM LED blinks in two modes: blinking in groups of between 2 and 8 times (0.2 second on and 0.2 second off) and repeating the same number after 1.2 second each; and the ALARM LED turns on.

Number of ALARM LED Blinks	Type of alarm and possible cause	Remedial action
2	Overload protection Overloading.	Reduce the motor load.
3	Overvoltage protection Incorrect power connection or loading beyond the regenerative ability of the driver.	<ul style="list-style-type: none"> • Check power-supply connections. • Reduce load in a vertical-travel application.
4	Speed error protection Overloading or incorrect speed filter setting.	Reduce load or slightly increase the speed-filter setting.
6	Excessive speed Excessively high operating-pulse speed.	Set the speed of the motor shaft at 5000 r/min or less.
7	EEPROM data error Error in driver.	Turn on the driver power. If the error persists, please contact the nearest office.
8	Sensor error Bad motor-cable connection or open line.	Shut off the driver power and check the motor cable and driver connectors. Then turn the driver power back on.
ALARM LED turns on.	System error The driver is out of order.	Turn the driver power on. If the error persists, please contact the nearest office.

11 Options (Sold separately)

- Extension cable

Required to extend the distance between the motor and driver.

- Extension cable

Model	Length [m (ft.)]
CC01AIP	1 (3.3)
CC02AIP	2 (6.6)
CC03AIP	3 (9.8)
CC05AIP	5 (16.4)
CC07AIP	7 (23)
CC10AIP	10 (32.8)

- Extension cable for electromagnetic brake

Model	Length [m (ft.)]
CC01AIPM	1 (3.3)
CC02AIPM	2 (6.6)
CC03AIPM	3 (9.8)
CC05AIPM	5 (16.4)
CC07AIPM	7 (23)
CC10AIPM	10 (32.8)

- Flexible extension cable

Highly flexible cable required to extend the distance between the motor and driver.

- Flexible extension cable

Model	Length [m (ft.)]
CC01SAR	1 (3.3)
CC02SAR	2 (6.6)
CC03SAR	3 (9.8)
CC05SAR	5 (16.4)
CC07SAR	7 (23)
CC10SAR	10 (32.8)

- Flexible extension cable for electromagnetic brake

Model	Length [m (ft.)]
CC01SARM2	1 (3.3)
CC02SARM2	2 (6.6)
CC03SARM2	3 (9.8)
CC05SARM2	5 (16.4)
CC07SARM2	7 (23)
CC10SARM2	10 (32.8)

- Driver cable

Cable with connectors for driver control input/output (36 pins), providing excellent noise resistance.

Model	Length [m (ft.)]
CC36D1-1	1 (3.3)
CC36D2-1	2 (6.6)

- Connector-terminal block conversion unit

Use this cable to connect the driver to a host controller via the terminal block.

[Cable length: 1 m (3.3 ft.)]

Model: **CC36T1**

- Unauthorized reproduction or copying of all or part of this manual is prohibited. If a new copy is required to replace an original manual that has been damaged or lost, please contact your nearest Oriental Motor branch or sales office.
- Oriental Motor shall not be liable whatsoever for any problems relating to industrial property rights arising from use of any information, circuit, equipment or device provided or referenced in this manual.
- Characteristics, specifications and dimensions are subject to change without notice. While we make every effort to offer accurate information in the manual, we welcome your input. Should you find unclear descriptions, errors or omissions, please contact the nearest office.
- **Orientalmotor** is a trademark of Oriental Motor Co., Ltd.
QSTEP is a trademark of Oriental Motor Co., Ltd., and is registered in Japan and other countries.
Other product names and company names mentioned in this manual may be trademarks or registered trademarks of their respective companies and are hereby acknowledged. The third-party products mentioned in this manual are recommended products, and references to their names shall not be construed as any form of performance guarantee. Oriental Motor is not liable whatsoever for the performance of these third-party products.

© Copyright ORIENTAL MOTOR CO., LTD. 2006

- Please contact your nearest Oriental Motor office for further information.

ORIENTAL MOTOR U.S.A. CORP.
Technical Support Line Tel:(800)468-3982
Available from 7:30 AM to 5:00 PM, P.S.T.
E-mail: techsupport@orientalmotor.com
www.orientalmotor.com

ORIENTAL MOTOR (EUROPA) GmbH
Headquarters and Düsseldorf Office
Tel:0211-5206700 Fax:0211-52067099
Munich Office
Tel:08131-59880 Fax:08131-598888
Hamburg Office
Tel:040-76910443 Fax:040-76910445

ORIENTAL MOTOR (UK) LTD.
Tel:01256-347090 Fax:01256-347099

ORIENTAL MOTOR (FRANCE) SARL
Tel:01 47 86 97 50 Fax:01 47 82 45 16

ORIENTAL MOTOR ITALIA s.r.l.
Tel:02-93906346 Fax:02-93906348

TAIWAN ORIENTAL MOTOR CO.,LTD.
Tel:(02)8228-0707 Fax:(02)8228-0708

SINGAPORE ORIENTAL MOTOR PTE LTD
Tel:(6745)7344 Fax:(6745)9405

ORIENTAL MOTOR (MALAYSIA) SDN. BHD.
Tel:(03)22875778 Fax:(03)22875528

INA ORIENTAL MOTOR CO.,LTD.
KOREA
Tel:(032)822-2042~3 Fax:(032)819-8745

ORIENTAL MOTOR CO.,LTD.
Headquarters Tokyo, Japan
Tel:(03)3835-0684 Fax:(03)3835-1890