

HBL Series

This slim line motor and compact driver produces constant torque throughout its speed range of 300~2000 r/min.

The **HBL** series is suitable for smaller size applications.

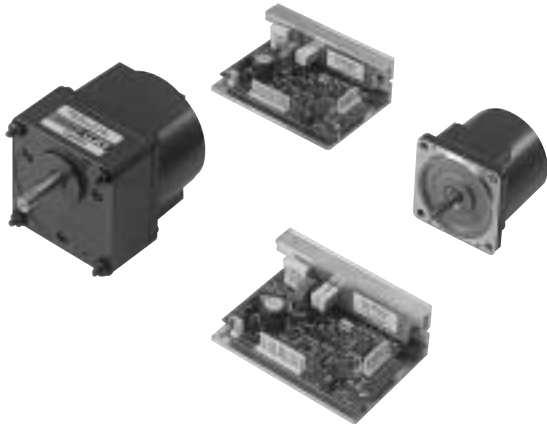

In the **HBL** series, a driver is provided with a motor as a package. (Gearhead shown in the picture is sold separately.)



■Features

- Compact board level driver is suitable for smaller sized applications.
- In addition to the “Overload protection” the HBL series also incorporates “Out-of-Phase protection.” In the event of a problem, the motor is brought to a stop and an alarm signal is output.
- To improve the reliability of feedback signals over longer distances, an optional extension cable is available. This increases the distance between the motor and driver to 16.4 ft. (5m)[60W, 100W] and 6.6 ft. (2m)[10W~40W]
- The motor features a compact design, enabling it to be installed in tight spaces.
- DC24V (DC48V) input makes it possible to switch to a backup power supply in the event of a power failure.
- Speed can be varied over a continuous range from 300 r/min to 2000 r/min with uniform torque throughout.
- The motor can be started, reversed and brought to an instantaneous stop using an electrical input control from the PLC.
- The pinion shaft model can be used with **GN** gearheads, thus enabling it to be combined with a wide range of gear ratios.
- For easy installation, 60W or 100W motors and gearhead come pre-assembled in the combination type.

■Product Number Code

HBL 5 40 K - GN

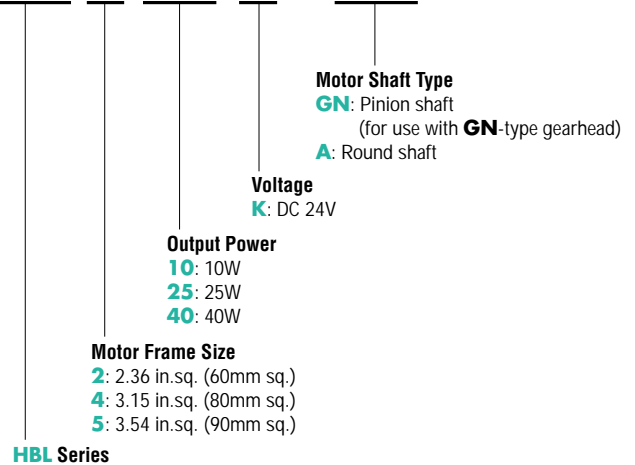

HBL 5 60 N - 5

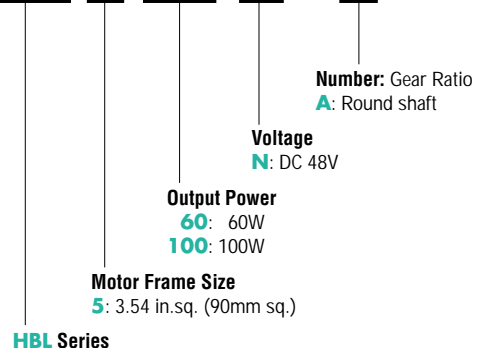

■ Type

● For 10W, 25W, 40W

Output Power		Pinion shaft type	Round shaft type
HP	W		
1/75	10	HBL210K-GN	HBL210K-AA
1/30	25	HBL425K-GN	HBL425K-AA
1/18.7	40	HBL540K-GN	HBL540K-AA

● When connecting gearheads, be sure to match the pinion shafts and frame sizes.

● GN Type Gearheads

Model
2GN3KA~2GN180KA
2GN10XK (Decimal Gearhead)
4GN3KA~4GN180KA
4GN10XK (Decimal Gearhead)
5GN3KA~5GN180KA
5GN10XK (Decimal Gearhead)

● For 60W, 100W Combination model type

Output Power		Model
HP	W	
1/12.4	60W	HBL560N-5~20
		HBL560N-30~100
		HBL560N-200
1/7.5	100W	HBL5100N-5~20
		HBL5100N-30~100
		HBL5100N-200

● For 60W, 100W Round shaft type

Output Power		Model
HP	W	
1/12.4	60W	HBL560N-A
1/7.5	100W	HBL5100N-A

■ Construction

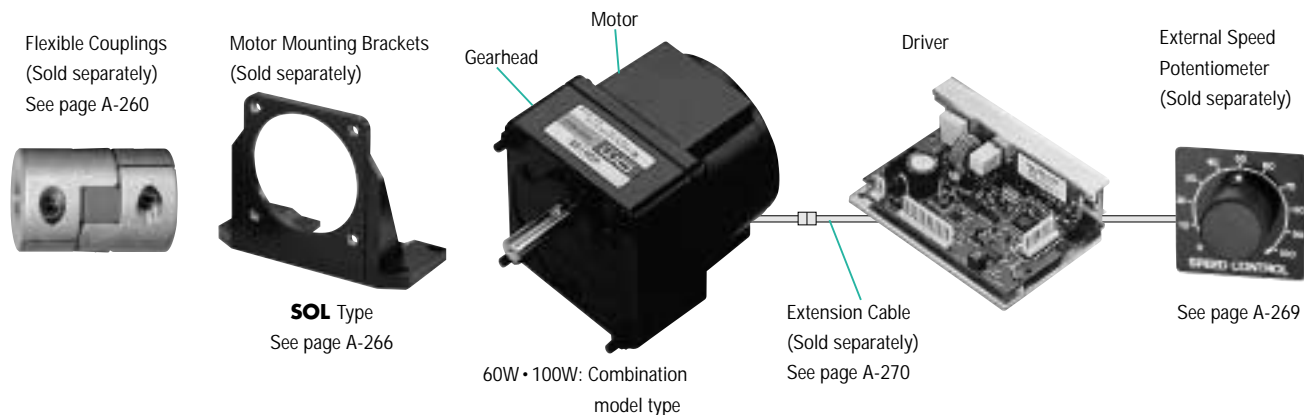

■ List of Motor and Driver Combinations

Model numbers for motor / driver combinations are shown below.

● For 10W, 25W, 40W Pinion shaft type

Output Power		Model	Motor Model	Driver Model
HP	W			
1/75	10	HBL210K-GN	HBLM210K-GN	HBLD10K
1/30	25	HBL425K-GN	HBLM425K-GN	HBLD25K
1/18	40	HBL540K-GN	HBLM540K-GN	HBLD40K

● For Round shaft type

Output Power		Model	Motor Model	Driver Model
HP	W			
1/75	10	HBL210K-AA	HBLM210K-AA	HBLD10K
1/30	25	HBL425K-AA	HBLM425K-AA	HBLD25K
1/18.7	40	HBL540K-AA	HBLM540K-AA	HBLD40K
1/12.4	60	HBL560N-A	HBLM560N-A	HBLD60N
1/7.5	100	HBL5100N-A	HBLM5100N-A	HBLD100N

● For 60W, 100W Combination model type

Output Power		Model	Motor Model	Gearhead Model	Driver Model
HP	W				
1/12.4	60	HBL560N-□	HBLM560N-GFH	GFH5G□	HBLD60N
1/7.5	100	HBL5100N-□	HBLM5100N-GFH	GFH5G□	HBLD100N

● When connecting gearheads, be sure to match the pinion shafts and frame sizes.
● Enter the gear ratio in the box (□) within the model number.

■ Specifications

Model	Pinion Shaft Type		HBL210K-GN	HBL425K-GN	HBL540K-GN	HBL560N-□	HBL5100N-□					
	Round Shaft Type		HBL210K-AA	HBL425K-AA	HBL540K-AA	HBL560N-A	HBL5100N-A					
Rated Speed	r/min		2000									
Rated Output Power	HP	W	1/75	10	1/30	25	1/18.7	40	1/12.4	60	1/7.5	100
Rated Torque	oz-in	(N·m)	6.9	(0.05)	17.4	(0.125)	27.8	(0.2)	41.6	(0.3)	69.4	(0.5)
Starting Torque	oz-in	(N·m)	8.3	(0.06)	20.8	(0.15)	33.3	(0.24)	50	(0.36)	83.3	(0.6)
Permissible Inertial Load	J	kgm ²	5×10 ⁻⁵		1.8×10 ⁻⁴		3.3×10 ⁻⁴		3.75×10 ⁻⁴		5.6×10 ⁻⁴	
		oz-in ²	2.7		9.8		18		20.5		30.6	
Variable Speed Range	r/min		300~2000									
Input Power	Voltage		DC24V±10%					DC48V±10%				
	Current		2.0A		3.5A		4.5A		3A		5A	
Input Power for Signals	DC5V±5%, 100mA min.											
Speed Control Methods	1. By built-in potentiometer 2. By external potentiometer 3. By DC voltage (0-5V DC)											
Speed Regulation	Load		-3% Max. (0-rated torque, at 2000 r/min)									
	Voltage		±2% Max. (Power supply voltage DC24V±10%, at 2000 r/min with no load)									
	Temperature		±2% Max. (32°F~104°F / 0°C~+40°C, at 2000 r/min with no load)									
Input Signal	C-MOS level negative logic		L (ON): 0~0.5V,		H (OFF): 4~5V							
	START/STOP		L: Start		H: Stop							
	BRAKE		L: Run		H: Brake							
	Direction of Rotation		L: CW		H: CCW							
	Speed Potentiometer Selection		L: Internal		H: External (HBL560, 5100 Type)							
Output Signal	Open collector output External use condition: DC26.4V, 10mA max. SPEED, ALARM											
Protection Functions	When the following are activated, the alarm signal will be output and the motor will come to a stop: ●Overload Protection: This will be activated within approximately 5 seconds of the motor load exceeding rated torque. ●Out-of-Phase Protection: This will be activated when motor signals are abnormal, due to disconnection of cable, etc.											
Motor Insulation Class	Class E [248°F(120°C)]											
Rating	Continuous											

Caution: HBL Series motors should not be used in gravitational applications in which they are driven by the load since doing so can cause the inverter's primary voltage to exceed the maximum limit and damage the driver.

■ General Specifications

Item	Motor	Driver
Insulation Resistance	100MΩ or more when 500V DC is applied between the windings and the frame.	100MΩ or more when 500V DC is applied between the FG and the power supply input terminal.
Dielectric Strength	Sufficient to withstand 0.5kV at 50Hz applied between the windings and the frame for 1 minute.	Sufficient to withstand 0.5kV at 50Hz applied between the FG and the power supply input terminal for 1 minute.
Operating Environmental Conditions	Ambient Temperature	32°F~122°F (0~+50°C), nonfreezing
	Humidity	85% maximum, noncondensing
	Atmosphere	No corrosive gases or dust

■ Gearmotor — Torque Table

Unit = Upper values: lb-in / Lower values: N·m

Model	Speed r/min	100	83	60	50	40	33	24	20	17	12	10	8.3	6	5	4	3.3	3	2.5	2	1.7
		667	556	400	333	267	222	160	133	111	80	67	56	40	33	27	22	20	17	13	11
Gear Ratio		3	3.6	5	6	7.5	9	12.5	15	18	25	30	36	50	60	75	90	100	120	150	180
HBL210K-GN/2GN □ KA	1	1.3	1.7	2.1	2.6	3.1	4.4	5.2	6.3	7.9	9.4	11	14	17	21	26	26	26	26	26	26
	0.12	0.15	0.2	0.24	0.3	0.36	0.51	0.61	0.73	0.91	1.1	1.3	1.7	2	2.5	3	3	3	3	3	3
HBL425K-GN/4GN □ KA	2.6	3.2	4.4	5.3	6.6	7.9	11	13	16	20	24	29	36	43	54	65	69	69	69	69	69
	0.3	0.36	0.51	0.61	0.76	0.91	1.3	1.5	1.8	2.3	2.7	3.3	4.1	5	6.2	7.4	8	8	8	8	8
HBL540K-GN/5GN □ KA	4.2	5.1	7	8.4	11	13	18	21	25	32	38	46	57	69	86	87	87	87	87	87	87
	0.49	0.58	0.81	0.97	1.2	1.5	2	2.4	2.9	3.7	4.4	5.3	6.6	7.9	9.9	10	10	10	10	10	10

- Enter the gear ratio in the box (□) within the model number.
- A colored background indicates gear shaft rotation in the same direction as the motor shaft; a white background indicates rotation in the opposite direction.

Unit = Upper values: lb-in / Lower values: N·m

Model	Gear Ratio	5	10	15	20	30	50	100	200
		Speed r/min	60~400	30~200	20~133	15~100	10~67	6~40	3~20
HBL560N -□	12	23	35	47	67	112	224	260	
	1.4	2.7	4.1	5.4	7.7	13	26	30	
HBL5100N -□	20	39	59	78	112	187	260	260	
	2.3	4.5	6.8	9	13	22	30	30	

- Enter the gear ratio in the box (□) within the model number.
- A colored background indicates gear shaft rotation in the same direction as the motor shaft; a white background indicates rotation in the opposite direction.

■ Permissible Overhung Load and Permissible Thrust Load

Gearhead Model	Gear Ratio	Permissible Overhung Load		Permissible Thrust Load	
		lb	(N)	lb	(N)
2GN □ KA	3~18	11	(50)	6.7	(30)
	25~180	26	(120)		
4GN □ KA	3~18	22	(100)	11	(50)
	25~180	44	(200)		
5GN □ KA	3~18	55	(250)	22	(100)
	25~180	66	(300)		
HBL560N -□	5	66	(300)	33	(150)
	10~20	88	(400)		
HBL5100N -□	30~200	110	(500)		

- Enter the gear ratio in the box (□) within the model number.

■ Permissible Inertial Load (J)

Unit = Upper values: lb-in² / Lower values: ×10⁻⁴kgm²

Model	Gear Ratio	3	3.6	5	6	7.5	9	12.5	15	18	25	30	36	50	60	75	90	100	120	150	180
		HBL210K-GN/2GN □ KA	0.189	0.272	0.525	0.756	1.18	1.7	3.28	4.73	6.8	13.1	18.9	27.2	52.5	52.5	52.5	52.5	52.5	52.5	52.5
HBL425K-GN/4GN □ KA	0.558	0.804	1.55	2.23	3.49	5.02	9.69	14	20.1	38.8	55.8	80.4	155	155	155	155	155	155	155	155	155
HBL540K-GN/5GN □ KA	0.684	0.985	1.9	2.74	4.28	6.16	11.9	17.1	24.6	47.5	68.4	98.5	190	190	190	190	190	190	190	190	190
	1.98	2.85	5.5	7.92	12.4	17.8	34.4	49.5	71.3	138	198	285	550	550	550	550	550	550	550	550	550
HBL560N -□	1.17	1.68	3.25	4.68	7.31	10.5	20.3	29.3	42.1	81.3	117	168	325	325	325	325	325	325	325	325	325
	3.6	5.18	10	14.4	22.5	32.4	62.5	90	130	250	360	518	1000	1000	1000	1000	1000	1000	1000	1000	1000
HBL5100N -□	5	34	76.5	136	306	850	850	850													
	25	100	225	400	900	2500	2500	2500													

- Enter the gear ratio in the box (□) within the model number.

■ Torque-Speed Characteristics

● Continuous Duty Region

Continuous operation is possible in this region.

● Limited Duty Region

This region is used primarily when accelerating. When a load that exceeds the rated torque is applied continuously for approximately 5 seconds, overload protection is activated and the motor comes to stop.

HBL210K-GN
HBL210K-AA

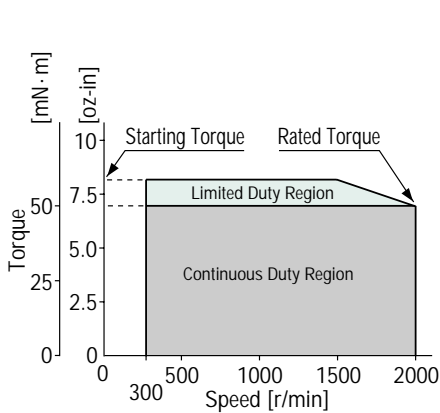

HBL425K-GN
HBL425K-AA

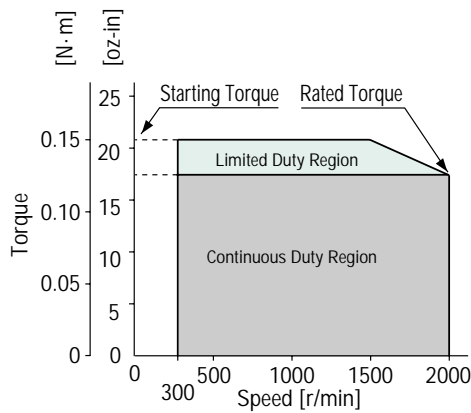

HBL540K-GN
HBL540K-AA

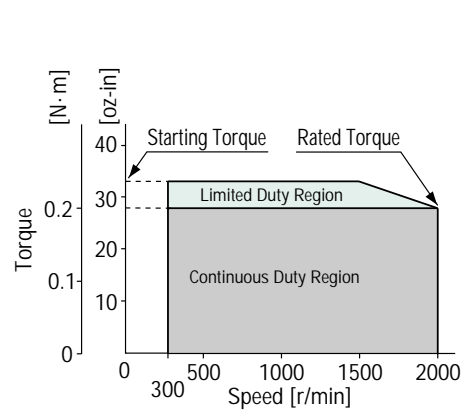

HBL560N-□
HBL560N-A

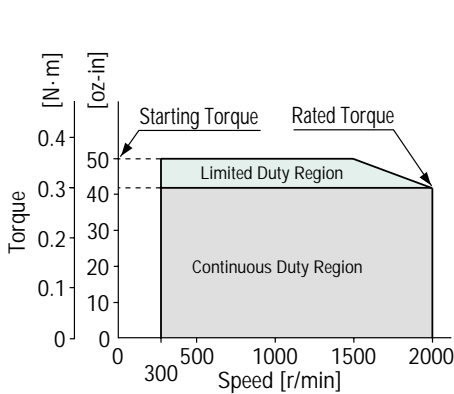

HBL5100N-□
HBL5100N-A

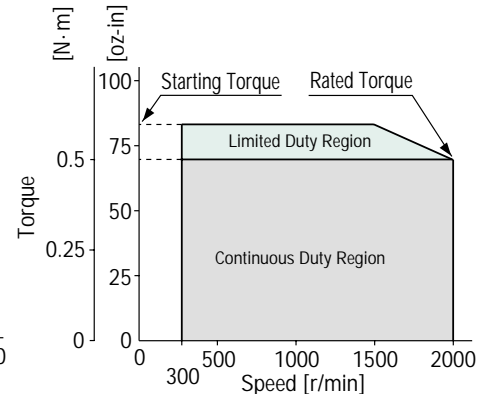

* The combination type is the value for the motor alone.

■ Wiring Diagrams

● HBL210, HBL425, HBL540

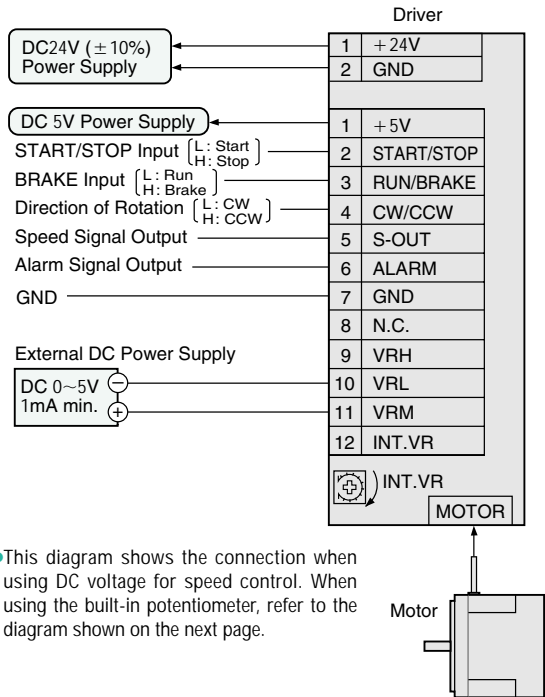

● HBL560, HBL5100

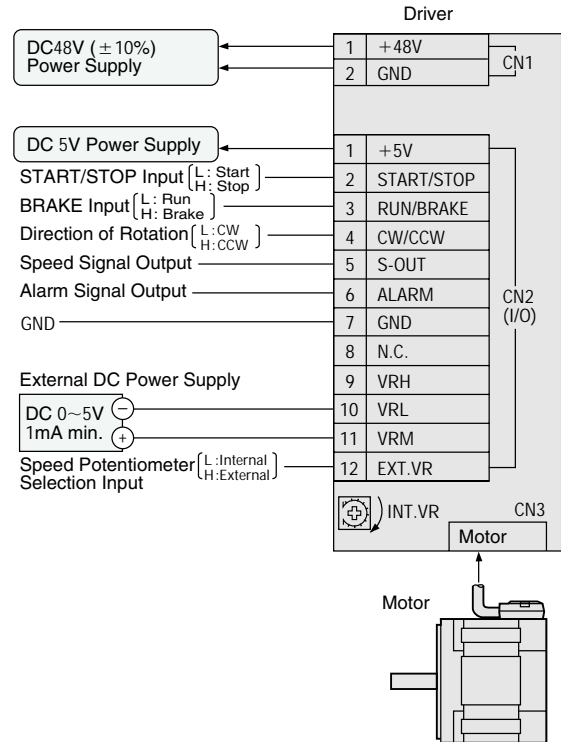

■ Signal Input Timing Chart

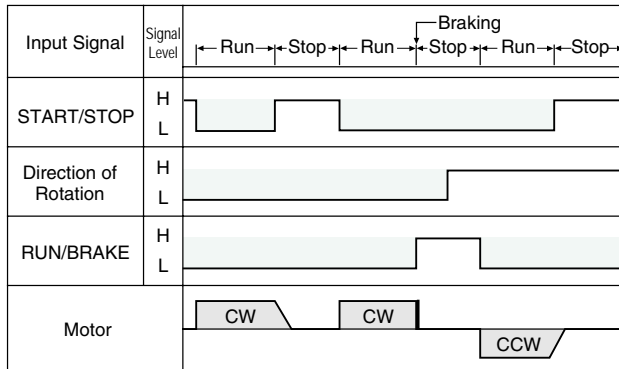

● RUN/BRAKE

The brake input runs or stops the motor when START/STOP input has been set to "L" level, the motor rotates at the speed selected; if set to "H" level, the motor stops instantaneously.

● Direction of Rotation

The direction of rotation can be changed by the direction of rotation input. The diagram shows the direction of motor shaft rotation as viewed from the motor shaft.

■ Control by Small Capacity Relays or Switches

● HBL210, HBL425, HBL540

Switch Capacity: DC24V 10mA

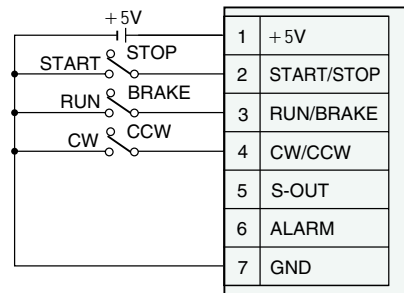

● HBL560, HBL5100

Switch Capacity: DC24V 10mA

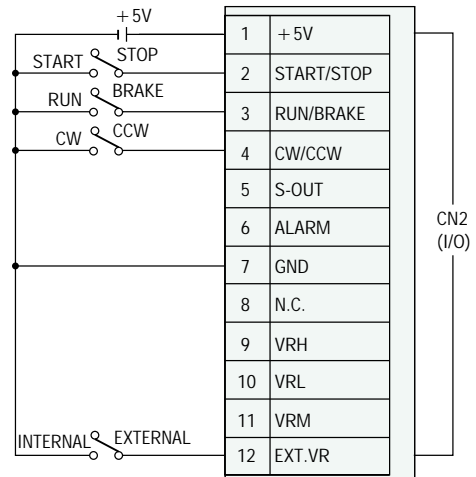

■ Speed Control

① Speed Control by Built-in Potentiometer

● HBL210, HBL425, HBL540

Connect terminals 11 and 12, and turn the potentiometer clockwise to increase the speed.

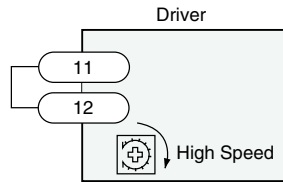

● HBL560, HBL5100

The EXT, VR input has been set to OFF ("L"Level), and turn the potentiometer clockwise to increase the speed.

② Speed Control by External Potentiometer

To control the speed of the motor when it is separated from the driver, connect the external potentiometer provided with the motor as follows.

External Potentiometer **PAVR-20KY** (Sold separately)

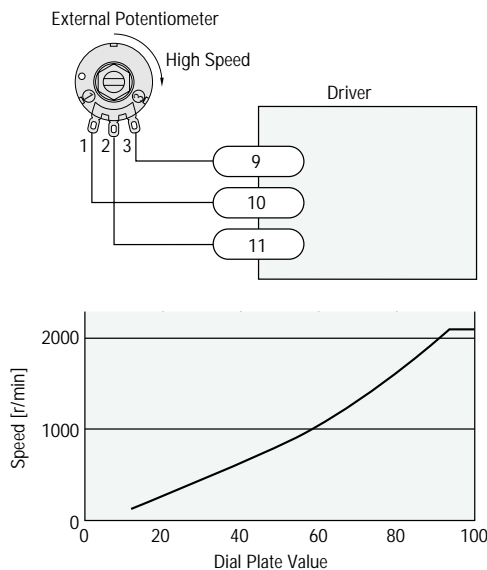

③ Speed Control by DC Voltage

To control the speed of the motor by DC voltage, connect the DC power supply as follows.

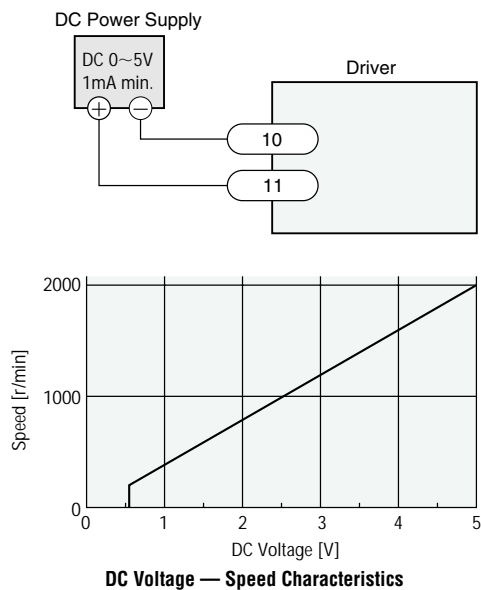

■ Connection of Output Signals

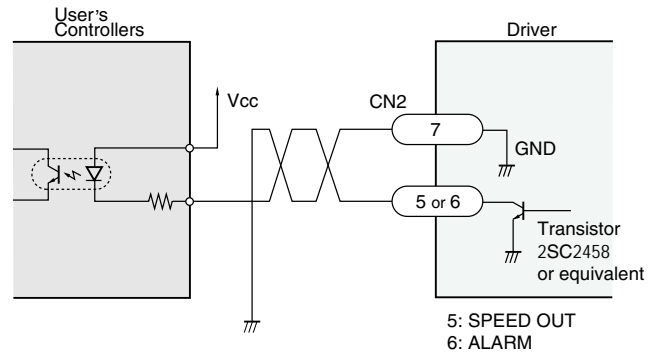

Speed Signal Output:

It is output at a rate of 12 pulses per motor rotation. Motor speed can be determined using the following formula:

$$\text{Motor speed} = \frac{\text{Speed output frequency [Hz]}}{12} \times 60 [\text{r/min}]$$

Alarm Signal Output:

This signal is output when protection for overload or out-of-phase has been activated.

Note:

- Signal output is done through an open collector transistor which requires an external power source.
- The external power source should be less than DC 26.4V. The transistor in the driver requires less than 10mA.

■ Dimensions Scale 1/4, Unit = inch (mm)

HBL210K-GN (Pinion Shaft Type)

Motor: HBLM210K-GN Weight (Mass): 1.32 lb. (0.6 kg) /

Driver: HBLD10K

Gearhead: **2GN□KA** Weight (Mass): 0.88 lb. (0.4 kg)

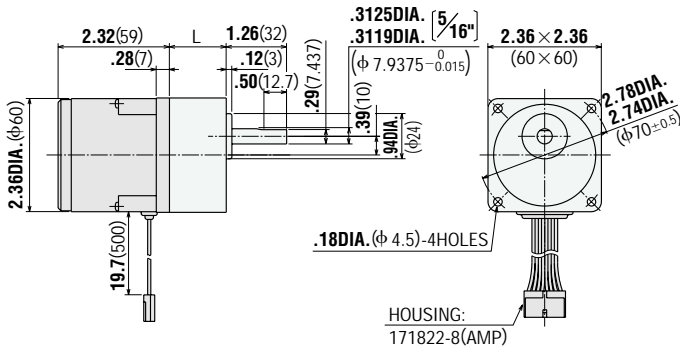

$L = 1.18$ (30) **2GN3KA~18KA**

$L = 1.57$ (40) **2GN25KA~180KA**

HBL210K-AA (Round Shaft Type)

Motor: HBLM210K-AA Weight (Mass): 1.32 lb. (0.6 kg)

Driver: HBLD10K

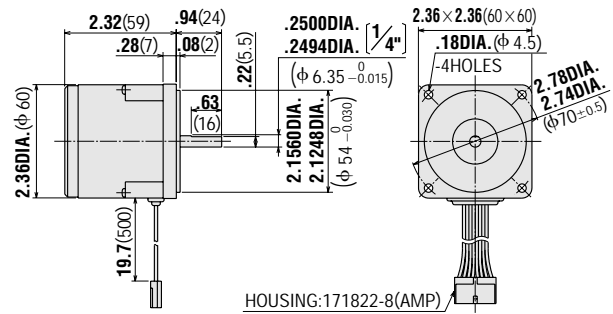

HBL425K-GN (Pinion Shaft Type)

Motor: HBLM425K-GN Weight (Mass): 2.2 lb. (1.0 kg) /

Driver: HBLD25K

Gearhead: **4GN□KA** Weight (Mass): 1.32 lb. (0.6 kg)

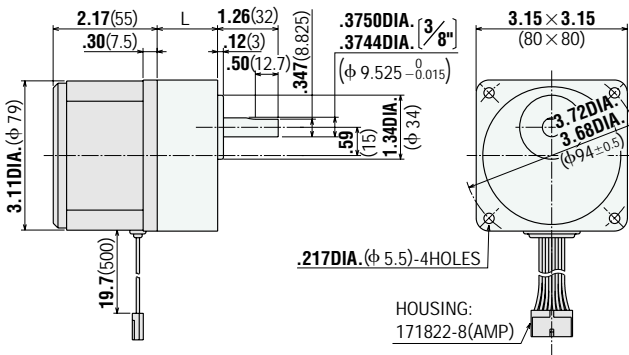

$L = 1.26$ (32) **4GN3KA~18KA**

$L = 1.67$ (42.5) **4GN25KA~180KA**

HBL425K-AA (Round Shaft Type)

Motor: HBLM425K-AA Weight (Mass): 2.2 lb. (1.0 kg)

Driver: HBLD25K

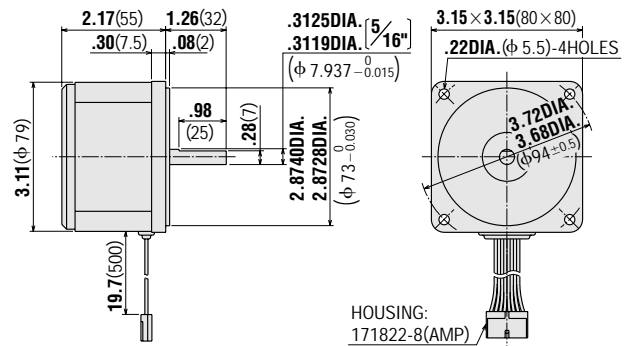

HBL540K-GN (Pinion Shaft Type)

Motor: HBLM540K-GN Weight (Mass): 2.9 lb. (1.3 kg) /

Driver: HBLD40K

Gearhead: **5GN□KA** Weight (Mass): 3.3 lb. (1.5 kg)

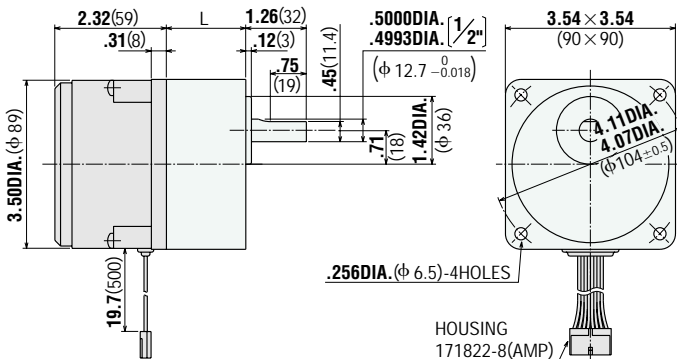

$L = 1.65$ (42) **5GN3KA~18KA**

$L = 2.36$ (60) **5GN25KA~180KA**

HBL540K-AA (Round Shaft Type)

Motor: HBLM540K-AA Weight (Mass): 2.9 lb. (1.3 kg)

Driver: HBLD40K

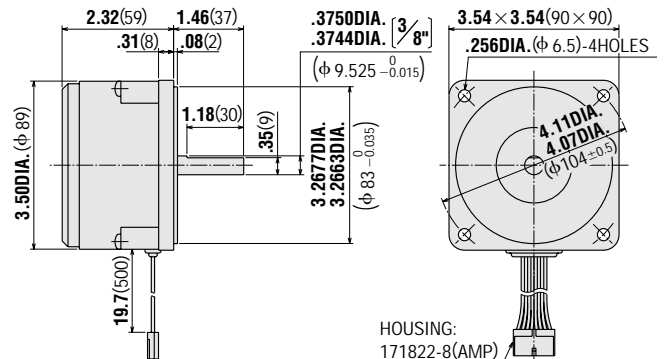

● **HBL560N**-□ (Combination Model)

Motor: HBLM560N-GFH / Gearhead: GFH5G□

Driver: HBLD60N

Weight (Mass): 6.6 lb. (3.0kg)

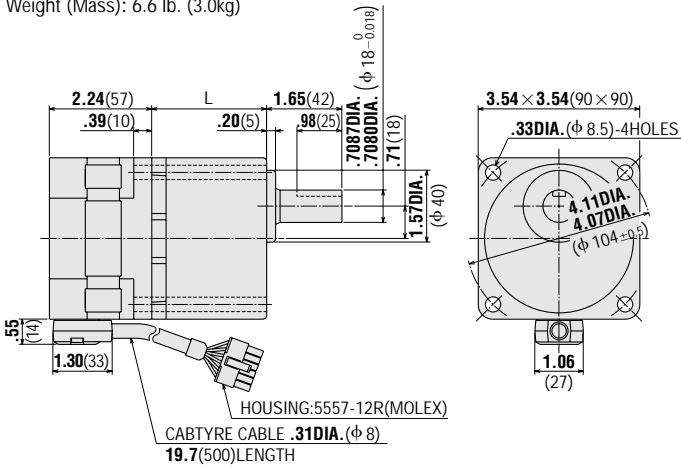

- L = 1.77 (45) **HBL560N-5~20**
- L = 2.28 (58) **HBL560N-30~100**
- L = 2.52 (64) **HBL560N-200**

● **HBL560N-A** (Round Shaft Type)

Motor: HBLM560N-A

Driver: HBLD60N

Weight (Mass): 3.3 lb. (1.5kg)

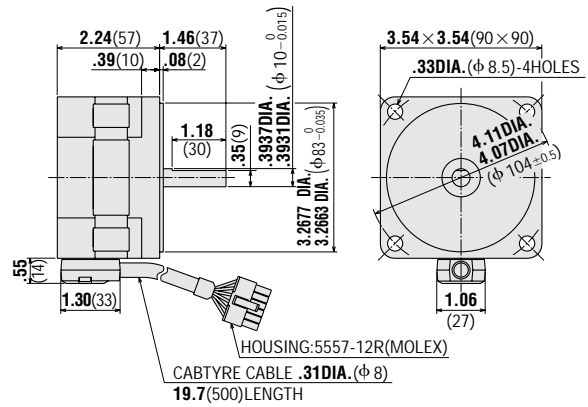

● **HBL5100N**-□ (Combination Model)

Motor: HBLM5100N-GFH / Gearhead: GFH5G□

Driver: HBLD100N

Weight (Mass): 8.8 lb. (4.0kg)

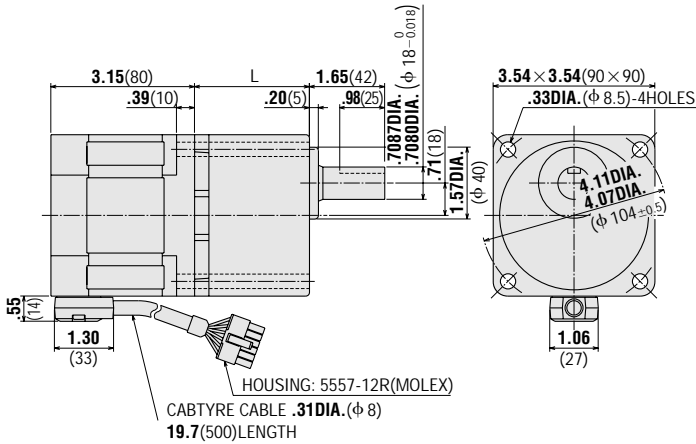

- L = 1.77 (45) **HBL5100N-5~20**
- L = 2.28 (58) **HBL5100N-30~100**
- L = 2.52 (64) **HBL5100N-200**

● **HBL5100N-A** (Round Shaft Type)

Motor: HBLM5100N-A

Driver: HBLD100N

Weight (Mass): 5.5 lb. (2.5kg)

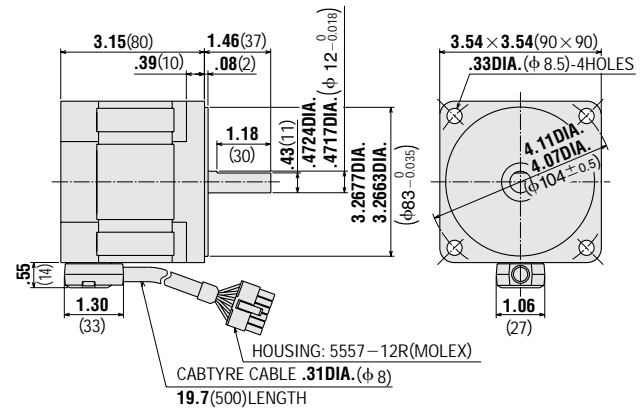

● Key and Key Slot

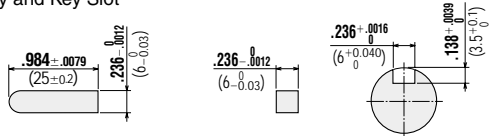

● Driver

HBLD10K, HBLD25K, HBLD40K

Weight (Mass): 0.4 lb. (0.2kg)

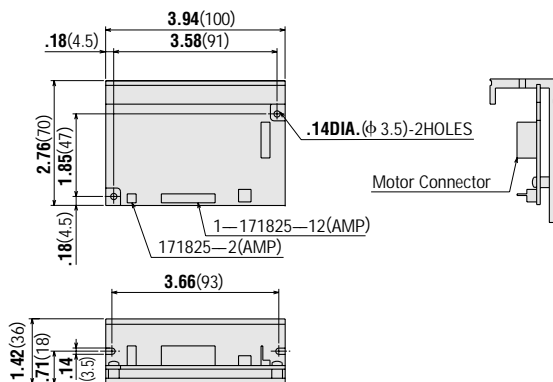

HBLD60N, HBLD100N

Weight (Mass): 0.5 lb. (0.24kg)

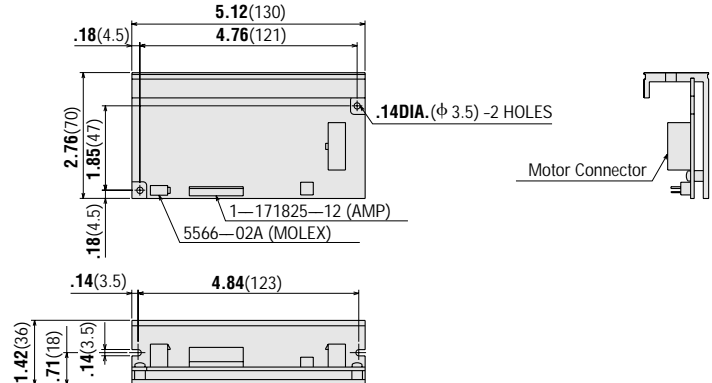

● Input Signal Cable (included)

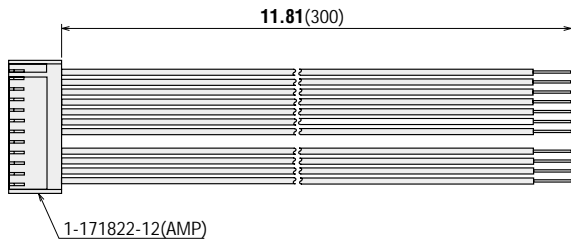

● Power Supply Cable (included)
HBL210, HBL425, HBL540

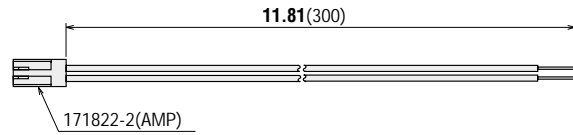

HBL560, HBL5100

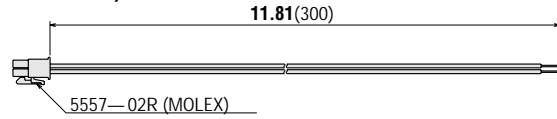

■ Accessories (sold separately)

● Extension Cable

● **HBL210, HBL425, HBL540** (Motor model)
FC02HBL (Cable model)

Using the extension cable allows the motor and driver to be separated by up to 6.6 ft. (2m)

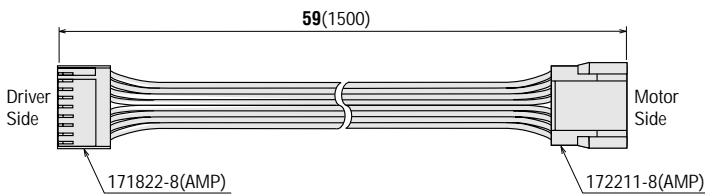

● **HBL560, HBL5100** (Motor model)

Using the extension cable allows the motor and driver to be separated by up to 18 ft. (5.5m)

Cable Model	Length	
	ft.	m
CC01FBL	3.3	1
CC02FBL	6.6	2
CC03FBL	9.8	3
CC05FBL	16.4	5

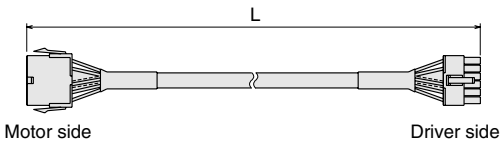

● Motor Mounting Brackets



Optional die-cast aluminum mounting brackets are available. They can be used to install motors without gearheads. See page A-266 for more information.

Motor Model	Mounting Bracket
HBL210	SOL2U08
HBL425	SOL4U10
HBL540	SOL5UA
HBL560	SOL5M8
HBL5100	SOL5M8

● Flexible couplings

Optional flexible couplings are available. See page [A-260] for more information.



● External Speed Potentiometer

PAVR-20KY



● Dimensions Weight (Mass): 0.08 lb. (35g)

