

Component Package Type Speed Control Motor Unit

SC Series

This speed control unit allows speed control and acceleration/deceleration operation in combination with speed control motors with an output power of 6W~60W. The control packs can be directly mounted on the control board.

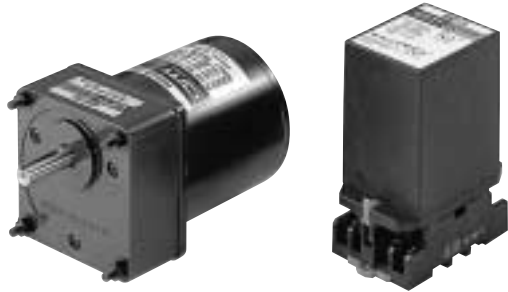

• The gearhead in the photograph is sold separately.



Product Number Code

SC 4 25 -4 0 1W U

Provided Capacitor
U: 110V/115V
E: 220V/230V

Voltage
1W: Single-Phase 110V/115V
2W: Single-Phase 220V/230V

Motor Type
O: Induction Motor (Continuous Rating)
T: Reversible Motor (30 Minute Rating)

Shaft Type
O: Round Shaft
4: GN type pinion shaft
5: GU type pinion shaft

Output Power
06: 6W **40:** 40W
15: 15W **60:** 60W
25: 25W

Motor Frame Size
2: 2.36 in.sq.(60mm sq.)
3: 2.76 in.sq.(70mm sq.)
4: 3.15 in.sq.(80mm sq.)
5: 3.54 in.sq.(90mm sq.)

SC series Speed Control Motor Unit

Note : The "U" and "E" at the end of the model number indicate that the unit includes a capacitor. These two letters are not listed on the motor nameplate.

Features

- Speed Range: 90 r/min~1400 r/min (50Hz), 90 r/min~1600 r/min (60Hz)
- Connection is simplified by a compact plug-in construction (11 pins).
- The control packs have an acceleration/deceleration function that enables smooth starts and stops. Setting and adjustment are easy since they have a built-in timing potentiometer for acceleration time and deceleration time.
- Multiple motors can be operated by a single speed potentiometer.
- Compatible with voltages in all major countries.
- The design conforms to typical global safety standards.
- The CE Marking is used in accordance with the low voltage directive.

Safety Standards and CE Marking

Approved Standards

Motor			
Standards	Certification Body	Standards File No.	CE Marking
UL1004 UL519 (SC206 type) UL547 (SC315, SC425, SC540, SC560 type) CAN/CSA-C22.2 No.100 CAN/CSA-C22.2 No.77	UL	E64199 (SC206 type) E64197 (SC315, US425, SC540, SC560 type)	Low voltage Directive
EN60950	VDE	114919UG (SC206 type) 6751UG (SC315, SC425, SC540, SC560 type)	
EN60034-1 EN60034-5 IEC60034-11	Conform to EN/IEC Standards (EN/IEC certifications are scheduled.)		

Speed control pack			
Standards	Certification Body	Standards File No.	CE Marking
UL508 CAN/CSA-C22.2 No.14	UL	E91291	Low voltage Directive
EN60950 DIN VDE 0160	TÜV Rheinland	R9551853	

- Note :**
- Each component is recognized individually and as a package.
 - The EMC measurements required under standard DIN VDE 0160 are not performed for motors and speed control packs. Perform the EMC test when they are incorporated into the final product.
 - The over-voltage protection test required under standard DIN VDE 0160 is not performed. Perform the test when incorporated into the final product.
 - For installations for EN/IEC standards, see page D-2.

■ Type

● Induction Motor Single-Phase 110V/115V

Output Power		Model	
HP	(W)	Pinion shaft	Round shaft
1/124	(6)	SC206-401WU	SC206-001WU
1/50	(15)	SC315-401WU	SC315-001WU
1/30	(25)	SC425-401WU	SC425-001WU
1/18.5	(40)	SC540-401WU	SC540-001WU
1/12.5	(60)	SC560-501WU	SC560-001WU

● Induction Motor Single-Phase 220V/230V

Output Power		Model	
HP	(W)	Pinion shaft	Round shaft
1/124	(6)	SC206-402WE	SC206-002WE
1/50	(15)	SC315-402WE	SC315-002WE
1/30	(25)	SC425-402WE	SC425-002WE
1/18.5	(40)	SC540-402WE	SC540-002WE
1/12.5	(60)	SC560-502WE	SC560-002WE

● Gearheads

Motor Model	Gearhead Model
SC206	2GN3KA ~ 2GN180KA
	2GN10XK (Decimal Gearhead)
SC315	3GN3KA ~ 3GN180K
	3GN10XK (Decimal Gearhead)
SC425	4GN3KA ~ 4GN180KA
	4GN10XK (Decimal Gearhead)
SC540	5GN3KA ~ 5GN180KA
	5GN10XK (Decimal Gearhead)
SC560	5GU3KA ~ 5GU180KA
	5GU10XKB (Decimal Gearhead)

● Reversible Motor Single-Phase 110V/115V

Output Power		Model	
HP	(W)	Pinion shaft	Round shaft
1/124	(6)	SC206-411WU	SC206-011WU
1/50	(15)	SC315-411WU	SC315-011WU
1/30	(25)	SC425-411WU	SC425-011WU
1/18.5	(40)	SC540-411WU	SC540-011WU
1/12.5	(60)	SC560-511WU	SC560-011WU

● Reversible Motor Single-Phase 220V/230V

Output Power		Model	
HP	(W)	Pinion shaft	Round shaft
1/124	(6)	SC206-412WE	SC206-012WE
1/50	(15)	SC315-412WE	SC315-012WE
1/30	(25)	SC425-412WE	SC425-012WE
1/18.5	(40)	SC540-412WE	SC540-012WE
1/12.5	(60)	SC560-512WE	SC560-012WE

■ Construction

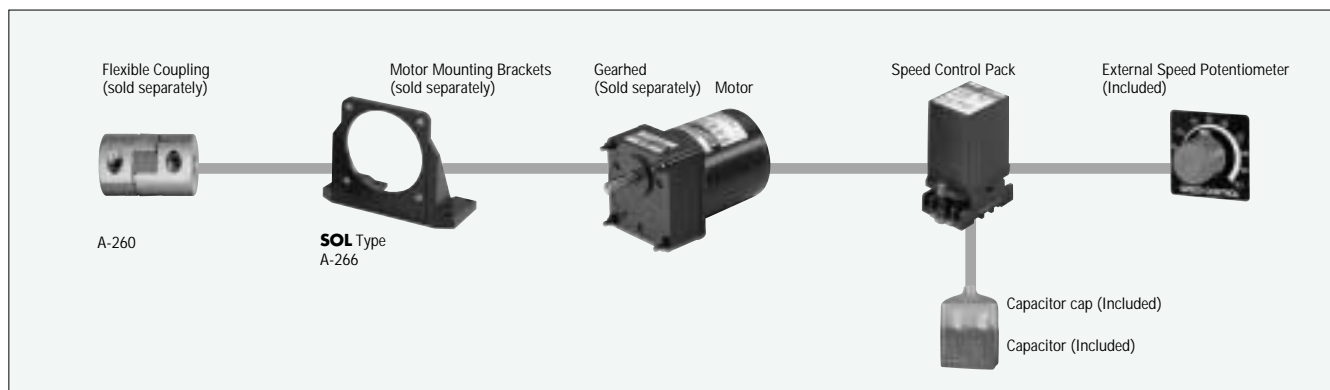

■ Specifications

● Induction Motors – Continuous Rating



Unit Model		Maximum Output Power HP W	Voltage V	Frequency Hz	Speed Range r/min	Permissible Torque				Starting Torque Current		Power Consumption W	Capacitor μF
Pinion Shaft Type	Round Shaft Type					1200 r/min	90 r/min	oz-in	mN·m	oz-in	mN·m		
ZP	SC206-401WU	1/124 6	Single-Phase110	60	90~1600	6.9	50	4.2	30	4.9	35	0.26	24
			Single-Phase115	60	90~1600	6.9	50	4.2	30	4.9	35	0.29	29
TP	SC315-401WU	1/50 15	Single-Phase110	60	90~1600	17.4	125	4.2	30	7.6	55	0.50	46
			Single-Phase115	60	90~1600	17.4	125	4.7	34	9.0	65	0.51	48
TP	SC425-401WU	1/30 25	Single-Phase110	60	90~1600	20.1	145	5.6	40	12.5	90	0.72	65
			Single-Phase115	60	90~1600	22.2	160	6.0	43	13.9	100	0.74	67
TP	SC540-401WU	1/18.5 40	Single-Phase110	60	90~1600	31.9	230	7.6	55	22.2	160	1.1	101
			Single-Phase115	60	90~1600	44.4	320	7.6	55	23.6	170	1.1	103
TP	SC560-501WU	1/12.5 60	Single-Phase110	60	90~1600	54.2	390	13.2	95	45.8	330	1.60	160
			Single-Phase115	60	90~1600	54.2	390	13.2	95	48.6	350	1.60	160
ZP	SC206-402WE	1/124 6	Single-Phase220	60	90~1600	6.9	50	4.2	30	4.2	30	0.14	29
			Single-Phase230	50	90~1400	6.9	50	4.2	30	4.9	35	0.14	30
			Single-Phase230	60	90~1600	6.9	50	4.2	30	4.9	35	0.14	30
TP	SC315-402WE	1/50 15	Single-Phase220	60	90~1600	15.3	110	4.2	30	8.1	58	0.23	44
			Single-Phase230	50	90~1400	17.4	125	4.7	34	9.0	65	0.23	44
			Single-Phase230	60	90~1600	17.4	125	4.7	34	9.0	65	0.23	47
TP	SC425-402WE	1/30 25	Single-Phase220	60	90~1600	20.1	145	5.6	40	13.9	100	0.35	65
			Single-Phase230	50	90~1400	28.5	205	6.0	43	15.3	110	0.34	61
			Single-Phase230	60	90~1600	22.2	160	6.0	43	15.3	110	0.35	65
TP	SC540-402WE	1/18.5 40	Single-Phase220	60	90~1600	31.9	230	8.3	60	25.0	180	0.55	97
			Single-Phase230	50	90~1400	44.4	320	9.0	65	27.8	200	0.55	92
			Single-Phase230	60	90~1600	33.3	240	9.0	65	27.8	200	0.56	98
TP	SC560-502WE	1/12.5 60	Single-Phase220	60	90~1600	68.0	490	25.0	180	44.4	320	0.92	180
			Single-Phase230	50	90~1400	68.0	490	26.4	190	48.6	350	0.98	186
			Single-Phase230	60	90~1600	68.0	490	26.4	190	48.6	350	0.93	186

● Reversible Motors – 30 Minutes Rating



Unit Model		Maximum Output Power HP W	Voltage V	Frequency Hz	Speed Range r/min	Permissible Torque				Starting Torque Current		Power Consumption W	Capacitor μF
Pinion Shaft Type	Round Shaft Type					1200 r/min	90 r/min	oz-in	mN·m	oz-in	mN·m		
ZP	SC206-411WU	1/124 6	Single-Phase110	60	90~1600	6.9	50	6.9	50	5.6	40	0.32	31
			Single-Phase115	60	90~1600	6.9	50	6.9	50	6.2	45	0.32	31
TP	SC315-411WU	1/50 15	Single-Phase110	60	90~1600	17.4	125	9.7	70	10.4	75	0.58	56
			Single-Phase115	60	90~1600	17.4	125	9.7	70	11.8	85	0.58	56
TP	SC425-411WU	1/30 25	Single-Phase110	60	90~1600	28.5	205	13.2	95	13.9	100	0.93	90
			Single-Phase115	60	90~1600	28.5	205	13.2	95	15.3	110	0.93	90
TP	SC540-411WU	1/18.5 40	Single-Phase110	60	90~1600	44.4	320	18.1	130	27.8	200	1.4	131
			Single-Phase115	60	90~1600	44.4	320	18.1	130	29.2	210	1.4	133
TP	SC560-511WU	1/12.5 60	Single-Phase110	60	90~1600	55.5	400	16.7	120	44.4	320	1.70	160
			Single-Phase115	60	90~1600	55.5	400	16.7	120	50.0	360	1.70	170
ZP	SC206-412WE	1/124 6	Single-Phase220	60	90~1600	6.9	50	6.9	50	5.3	38	0.16	30
			Single-Phase230	50	90~1400	6.9	50	6.9	50	6.2	45	0.16	33
			Single-Phase230	60	90~1600	6.9	50	6.9	50	6.0	43	0.16	33
TP	SC315-412WE	1/50 15	Single-Phase220	60	90~1600	17.4	125	9.7	70	12.5	90	0.29	53
			Single-Phase230	50	90~1400	17.4	125	9.7	70	13.9	100	0.3	63
			Single-Phase230	60	90~1600	17.4	125	9.7	70	13.9	100	0.29	53
TP	SC425-412WE	1/30 25	Single-Phase220	60	90~1600	28.5	205	13.2	95	18.1	130	0.44	84
			Single-Phase230	50	90~1400	28.5	205	13.2	95	20.8	150	0.44	82
			Single-Phase230	60	90~1600	28.5	205	13.2	95	19.4	140	0.44	86
TP	SC540-412WE	1/18.5 40	Single-Phase220	60	90~1600	44.4	320	19.4	140	36.1	260	0.73	129
			Single-Phase230	50	90~1400	44.4	320	18.1	130	41.7	300	0.71	120
			Single-Phase230	60	90~1600	44.4	320	19.4	140	40.3	290	0.73	129
TP	SC560-512WE	1/12.5 60	Single-Phase220	60	90~1600	68.0	490	31.9	230	50.0	360	1.1	215
			Single-Phase230	50	90~1400	68.0	490	30.6	220	56.9	410	1.1	205
			Single-Phase230	60	90~1600	68.0	490	31.9	230	55.5	400	1.1	218

ZP : These motors are impedance protected.

TP : These motors contain a built-in thermal protector. If a motor overheats for any reason, the thermal protector is opened and the motor stops. When the motor temperature drops, the thermal protector closes and the motor restarts. Be sure to turn the motor off before inspecting.

● The speed range is under no load conditions.

● The "U" and "E" at the end of the model number indicate that the unit includes a capacitor. These two letters are not listed on the motor nameplate.

■ General Specifications of Motors

After the rated motor operation under normal ambient temperature and humidity.

Item	Specifications
Insulation Resistance	100MΩ or more when 500V DC is applied between the windings and the frame.
Dielectric Strength	Sufficient to withstand 1.5kV at 50Hz and 60Hz applied between the windings and the frame for 1 minute.
Temperature Rise	Induction Motor: 144°F (80°C) or less measured by the resistance change method under no load operation of motor with connecting a gearhead or equivalent heat radiation plate.* Reversible Motor: 144°F (80°C) or less measured by the resistance change method under no load operation for 30 minutes of motor with connecting a gearhead or equivalent heat radiation plate.*
Insulation Class	Class B [266°F (130°C)]
Overheating Protection Device	SC206 type is impedance protected. The other types contain a built-in thermal protector (automatic return type). Open : 266°F±9°F (130°C±5°C) Close: 179.6°F±27°F (82°C±15°C)
Ambient Temperature Range	14°F~104°F (10°C~+40°C)
Ambient Humidity	85% maximum (noncondensing)
Degree of protection	SC206, SC315, SC425, SC540 type IP20 SC560 type IP40

*See page (A-37) for heat radiation plate sizes.

■ General Specifications of Speed Control Pack

Item	Specifications
Insulation Resistance	100MΩ or more when 500V DC is applied between all the pins and the frame.
Dielectric Strength	Sufficient to withstand 2.3kV at 60Hz (Single-Phase 220, 230V : 3.0kV at 50Hz) applied between all the pins and the frame for 1 minute.
Ambient Temperature Range	32°F~104°F (0°C~+40°C)
Ambient Humidity	85% maximum (noncondensing)
Degree of protection	Speed Control Pack: IP20 (after connecting to surface connection socket) Surface connection socket: IP10

■ Gearmotor — Torque Table

● Induction Motors

Unit = Upper values: lb-in/Lower values: N-m

Model	Gear Ratio	3	3.6	5	6	7.5	9	12.5	15	18	25	30	36	50	60	75	90	100	120	150	180
SC206-401WU /2GN□KA	1200r/min	1 0.12	1.3 0.15	1.7 0.2	2.1 0.24	2.6 0.3	3.1 0.36	4.4 0.51	5.2 0.61	6.3 0.73	7.9 0.91	9.4 1.1	11 1.3	14 1.7	17 2	21 2.5	26 3	26 3	26 3	26 3	26 3
	90r/min	0.64 0.073	0.77 0.087	1.1 0.12	1.3 0.15	1.6 0.18	1.9 0.22	2.7 0.3	3.2 0.36	3.8 0.44	4.8 0.55	5.7 0.66	6.9 0.79	8.7 0.99	10 1.2	13 1.5	16 1.8	17 2	21 2.4	26 3	26 3
SC206-402WE /2GN□KA	1200r/min	1 0.12	1.3 0.15	1.7 0.2	2.1 0.24	2.6 0.3	3.1 0.36	4.4 0.51	5.2 0.61	6.3 0.73	7.9 0.91	9.4 1.1	11 1.3	14 1.7	17 2	21 2.5	26 3	26 3	26 3	26 3	26 3
	90r/min	0.64 0.073	0.77 0.087	1.1 0.12	1.3 0.15	1.6 0.18	1.9 0.22	2.7 0.3	3.2 0.36	3.8 0.44	4.8 0.55	5.7 0.66	6.9 0.79	8.7 0.99	10 1.2	13 1.5	16 1.8	17 2	21 2.4	26 3	26 3
SC315-401WU /3GN□KA	1200r/min	2.6 0.3	3.2 0.36	4.4 0.51	5.3 0.61	6.6 0.76	7.9 0.91	11 1.3	13 1.5	16 1.8	20 2.3	24 2.7	29 3.3	36 4.1	43 5	43 5	43 5	43 5	43 5	43 5	43 5
	90r/min	0.71 0.083	0.86 0.099	1.2 0.14	1.4 0.17	1.8 0.21	2.1 0.25	3 0.34	3.6 0.41	4.3 0.5	5.4 0.62	6.4 0.74	7.7 0.89	9.7 1.1	12 1.3	15 1.7	17 2	19 2.2	23 2.7	29 3.4	35 4
SC315-402WE /3GN□KA	1200r/min	2.6 0.3	3.2 0.36	4.4 0.51	5.3 0.61	6.6 0.76	7.9 0.91	11 1.3	13 1.5	16 1.8	20 2.3	24 2.7	29 3.3	36 4.1	43 5	43 5	43 5	43 5	43 5	43 5	43 5
	90r/min	0.71 0.083	0.86 0.099	1.2 0.14	1.4 0.17	1.8 0.21	2.1 0.25	3 0.34	3.6 0.41	4.3 0.5	5.4 0.62	6.4 0.74	7.7 0.89	9.7 1.1	12 1.3	15 1.7	17 2	19 2.2	23 2.7	29 3.4	35 4
SC425-401WU /4GN□KA	1200r/min	3.4 0.39	4 0.47	5.6 0.65	6.7 0.78	8.4 0.97	10 1.2	14 1.6	17 1.9	20 2.3	25 2.9	30 3.5	36 4.2	46 5.3	55 6.3	69 7.9	69 8	69 8	69 8	69 8	69 8
	90r/min	0.91 0.1	1.1 0.13	1.5 0.17	1.8 0.21	2.3 0.26	2.7 0.31	3.8 0.44	4.6 0.52	5.5 0.63	6.8 0.78	8.2 0.94	9.9 1.1	12 1.4	15 1.7	19 2.1	22 2.6	25 2.8	30 3.4	37 4.3	45 5.1
SC425-402WE /4GN□KA	1200r/min 230V	4.3	5.2	7.2	8.7	11	13	18	22	26	33	39	47	59	69	69	69	69	69	69	69
	50Hz	0.5	0.6	0.83	1	1.2	1.5	2.1	2.5	3	3.7	4.5	5.4	6.8	8	8	8	8	8	8	8
	230V	3.4	4	5.6	6.7	8.4	10	14	17	20	25	30	36	46	55	69	69	69	69	69	69
	60Hz	0.39	0.47	0.65	0.78	0.97	1.2	1.6	1.9	2.3	2.9	3.5	4.2	5.3	6.3	7.9	8	8	8	8	8
SC540-401WU /5GN□KA	1200r/min	6.7 0.78	8.1 0.93	11 1.3	13 1.6	17 1.9	20 2.3	28 3.2	34 3.9	40 4.7	51 5.8	61 7	73 8.4	87 10	87 10	87 10	87 10	87 10	87 10	87 10	87 10
	90r/min	1.2 0.13	1.4 0.16	1.9 0.22	2.3 0.27	2.9 0.33	3.5 0.4	4.8 0.56	5.8 0.67	6.9 0.8	8.7 1	10 1.2	12 1.4	16 1.8	19 2.2	24 2.7	28 3.3	31 3.6	38 4.4	47 5.4	56 6.5

Unit = Upper values: lb-in/Lower values:N·m

Model	Gear Ratio	3	3.6	5	6	7.5	9	12.5	15	18	25	30	36	50	60	75	90	100	120	150	180		
SC540-402WE /5GN□KA	1200r/min 230V	6.7	8.1	11	13	17	20	28	34	40	51	61	73	87	87	87	87	87	87	87	87	87	
		0.78	0.93	1.3	1.6	1.9	2.3	3.2	3.9	4.7	5.8	7	8.4	10	10	10	10	10	10	10	10	10	10
	90r/min	5.1	6.1	8.4	10	13	15	21	25	30	38	46	55	69	82	87	87	87	87	87	87	87	87
		0.58	0.7	0.97	1.2	1.5	1.7	2.4	2.9	3.5	4.4	5.3	6.3	7.9	9.5	10	10	10	10	10	10	10	10
SC560-501WU /5GU□KA	1200r/min	1.4	1.6	2.3	2.7	3.4	4.1	5.7	6.8	8.2	10	12	15	19	22	28	33	37	45	56	67	77	
		0.16	0.19	0.26	0.32	0.39	0.47	0.66	0.79	0.95	1.2	1.4	1.7	2.1	2.6	3.2	3.9	4.3	5.1	6.4	7.7	8.8	
	90r/min	8.2	9.9	14	16	21	25	31	37	45	56	67	80	112	134	150	174	174	174	174	174	174	174
		0.95	1.1	1.6	1.9	2.4	2.8	3.6	4.3	5.1	6.4	7.7	9.3	13	15	17	20	20	20	20	20	20	20
SC560-502WE /5GU□KA	1200r/min	2	2.4	3.3	4	5	6	7.5	9	11	14	16	20	27	33	37	44	49	58	73	88	88	
		0.23	0.28	0.38	0.46	0.58	0.69	0.87	1	1.2	1.6	1.9	2.3	3.1	3.8	4.2	5	5.6	6.7	8.4	10	10	
	90r/min	10	12	17	21	26	31	39	47	56	70	84	101	140	168	174	174	174	174	174	174	174	174
		1.2	1.4	2	2.4	3	3.6	4.5	5.4	6.4	8.1	9.7	12	16	19	20	20	20	20	20	20	20	20
SC560-512WE /5GU□KA	1200r/min	4	4.8	6.7	8	10	12	15	18	22	27	33	39	54	65	73	88	97	117	146	174	174	
		0.46	0.55	0.77	0.92	1.2	1.4	1.7	2.1	2.5	3.1	3.8	4.5	6.3	7.5	8.4	10	11	13	17	20	20	
	90r/min	10	12	17	21	26	31	39	47	56	70	84	101	140	168	174	174	174	174	174	174	174	174
		1.2	1.4	2	2.4	3	3.6	4.5	5.4	6.4	8.1	9.7	12	16	19	20	20	20	20	20	20	20	20

● **Reversible Motors**

Unit = Upper values: lb-in/Lower values: N·m

Model	Gear Ratio	3	3.6	5	6	7.5	9	12.5	15	18	25	30	36	50	60	75	90	100	120	150	180		
SC206-411WU /2GN□KA	1200r/min	1	1.3	1.7	2.1	2.6	3.1	4.4	5.2	6.3	7.9	9.4	11	14	17	21	26	26	26	26	26	26	
		0.12	0.15	0.2	0.24	0.3	0.36	0.51	0.61	0.73	0.91	1.1	1.3	1.7	2	2.5	3	3	3	3	3	3	3
	90r/min	0.64	1.3	1.7	2.1	2.6	3.1	4.4	5.2	6.3	7.9	9.4	11	14	17	21	26	26	26	26	26	26	26
		0.073	0.15	0.2	0.24	0.3	0.36	0.51	0.61	0.73	0.91	1.1	1.3	1.7	2	2.5	3	3	3	3	3	3	3
SC206-412WE /2GN□KA	1200r/min	1	1.3	1.7	2.1	2.6	3.1	4.4	5.2	6.3	7.9	9.4	11	14	17	21	26	26	26	26	26	26	
		0.12	0.15	0.2	0.24	0.3	0.36	0.51	0.61	0.73	0.91	1.1	1.3	1.7	2	2.5	3	3	3	3	3	3	
	90r/min	0.64	1.3	1.7	2.1	2.6	3.1	4.4	5.2	6.3	7.9	9.4	11	14	17	21	26	26	26	26	26	26	26
		0.073	0.15	0.2	0.24	0.3	0.36	0.51	0.61	0.73	0.91	1.1	1.3	1.7	2	2.5	3	3	3	3	3	3	3
SC315-411WU /3GN□KA	1200r/min	2.6	3.2	4.4	5.3	6.6	7.9	11	13	16	20	24	29	36	43	43	43	43	43	43	43	43	
		0.3	0.36	0.51	0.61	0.76	0.91	1.3	1.5	1.8	2.3	2.7	3.3	4.1	5	5	5	5	5	5	5	5	5
	90r/min	1.5	1.8	2.5	2.9	3.7	4.4	6.1	7.4	8.8	11	13	16	20	24	30	36	40	43	43	43	43	43
		0.17	0.2	0.28	0.34	0.43	0.51	0.71	0.85	1	1.3	1.5	1.8	2.3	2.8	3.5	4.2	4.6	5	5	5	5	5
SC315-412WE /3GN□KA	1200r/min	2.6	3.2	4.4	5.3	6.6	7.9	11	13	16	20	24	29	36	43	43	43	43	43	43	43	43	
		0.3	0.36	0.51	0.61	0.76	0.91	1.3	1.5	1.8	2.3	2.7	3.3	4.1	5	5	5	5	5	5	5	5	5
	90r/min	1.5	1.8	2.5	2.9	3.7	4.4	6.1	7.4	8.8	11	13	16	20	24	30	36	40	43	43	43	43	43
		0.17	0.2	0.28	0.34	0.43	0.51	0.71	0.85	1	1.3	1.5	1.8	2.3	2.8	3.5	4.2	4.6	5	5	5	5	5
SC425-411WU /4GN□KA	1200r/min	4.3	5.2	7.2	8.7	11	13	18	22	26	33	39	47	59	69	69	69	69	69	69	69	69	
		0.5	0.6	0.83	1	1.2	1.5	2.1	2.5	3	3.7	4.5	5.4	6.8	8	8	8	8	8	8	8	8	8
	90r/min	2	2.4	3.3	4	5	6	8.4	10	12	15	18	22	27	33	41	49	54	65	69	69	69	69
		0.23	0.28	0.38	0.46	0.58	0.69	0.96	1.2	1.4	1.7	2.1	2.5	3.1	3.8	4.7	5.6	6.3	7.5	8	8	8	8
SC425-412WE /4GN□KA	1200r/min	4.3	5.2	7.2	8.7	11	13	18	22	26	33	39	47	59	69	69	69	69	69	69	69	69	
		0.5	0.6	0.83	1	1.2	1.5	2.1	2.5	3	3.7	4.5	5.4	6.8	8	8	8	8	8	8	8	8	8
	90r/min	2	2.4	3.3	4	5	6	8.4	10	12	15	18	22	27	33	41	49	54	65	69	69	69	69
		0.23	0.28	0.38	0.46	0.58	0.69	0.96	1.2	1.4	1.7	2.1	2.5	3.1	3.8	4.7	5.6	6.3	7.5	8	8	8	8
SC540-411WU /5GN□KA	1200r/min	6.7	8.1	11	13	17	20	28	34	40	51	61	73	87	87	87	87	87	87	87	87	87	
		0.78	0.93	1.3	1.6	1.9	2.3	3.2	3.9	4.7	5.8	7	8.4	10	10	10	10	10	10	10	10	10	10
	90r/min	2.7	3.3	4.6	5.5	6.9	8.2	11	14	16	21	25	30	37	45	56	67	75	87	87	87	87	87
		0.32	0.38	0.53	0.63	0.79	0.95	1.3	1.6	1.9	2.4	2.8	3.4	4.3	5.1	6.4	7.7	8.6	10	10	10	10	10
SC540-412WE /5GN□KA	1200r/min	6.7	8.1	11	13	17	20	28	34	40	51	61	73	87	87	87	87	87	87	87	87	87	
		0.78	0.93	1.3	1.6	1.9	2.3	3.2	3.9	4.7	5.8	7	8.4	10	10	10	10	10	10	10	10	10	10
	90r/min 230V	2.7	3.3	4.6	5.5	6.9	8.2	11	14	16	21	25	30	37	45	56	67	75	87	87	87	87	87
		0.32	0.38	0.53	0.63	0.79	0.95	1.3	1.6	1.9	2.4	2.8	3.4	4.3	5.1	6.4	7.7	8.6	10	10	10	10	10
SC560-511WU /5GU□KA	1200r/min	8.4	10	14	17	21	25	32	38	46	57	69	82	114	137	153	174	174	174	174	174	174	
		0.97	1.2	1.6	1.9	2.4	2.9	3.7	4.4	5.3	6.6	7.9	9.5	13	16	18	20	20	20	20	20	20	20
	90r/min	2.5	3	4.2	5.1	6.3	7.6	9.5	11	14	17	21	25	34	41	46	55	62	74	92	111	111	111
		0.29	0.34	0.49	0.58	0.73	0.87	1.1	1.3	1.6	2	2.4	2.9	4	4.8	5.3	6.4	7.1	8.5	11	13	13	13
SC560-512WE /5GU□KA	1200r/min	10	12	17	21	26	31	39	47	56	70	84	101	140	168	174	174	174	174	174	174	174	
		1.2	1.4	2	2.4	3	3.6	4.5	5.4	6.4	8.1	9.7	12	16	19	20	20	20	20	20	20	20	20
	90r/min 230V	4.6	5.6	7.7	9.3	12	14	17	21	25	32	38	45	63	76	85	102	113	135	169	174	174	174
		0.53	0.64	0.89	1.1	1.3	1.6	2	2.4	2.9	3.6	4.4	5.2	7.3	8.7	9.7	12	13	16	19	20	20	20
220V/230V	4.8	5.8	8.1	9.7	12	15	18	22	26	33	39	47	66	79	88	106	118	141	174	174	174	174	
	0.56	0.67	0.93	1.1	1.4	1.7	2.1	2.5	3	3.8	4.6	5.5	7.6	9.1	10	12	14	16	20	20	20	20	

● Gearheads and decimal gearheads are sold separately.

● Enter the gear ratio in the box (□) within the model number. A colored background indicates gear shaft rotation in the same direction as the motor shaft; a white background indicates rotation in the opposite direction.

● Values for permissible torque are calculated by taking the permissible torque at high speed (1200r/min) and low speed (90r/min) and multiplying by the gear ratio and gearhead efficiency.

Torque-Speed Characteristics

Induction Motors

Single-Phase 110V/115V

SC206-401WU
SC206-001WU

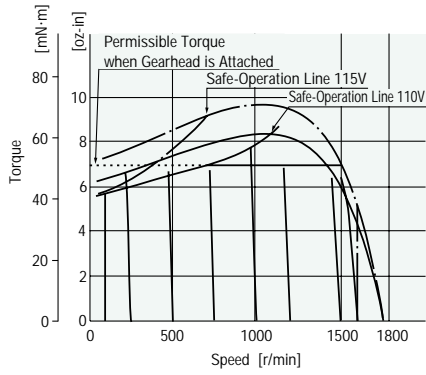

SC315-401WU
SC315-001WU

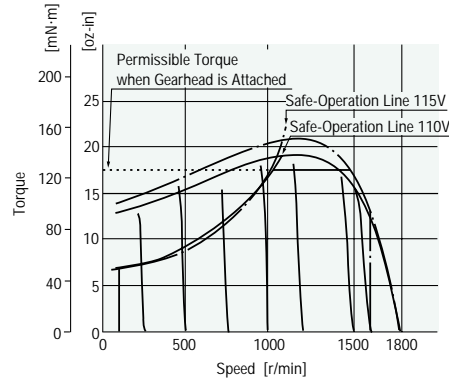

SC425-401WU
SC425-001WU

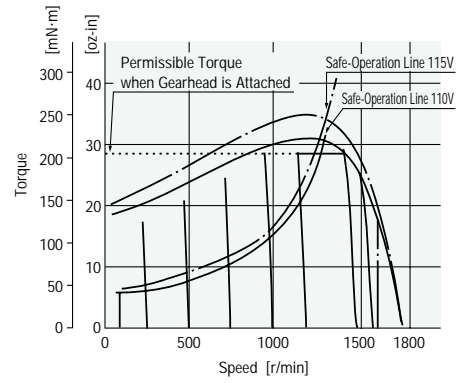

SC540-401WU
SC540-001WU

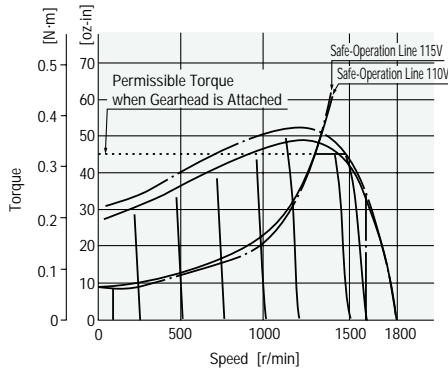

SC560-501WU
SC560-001WU

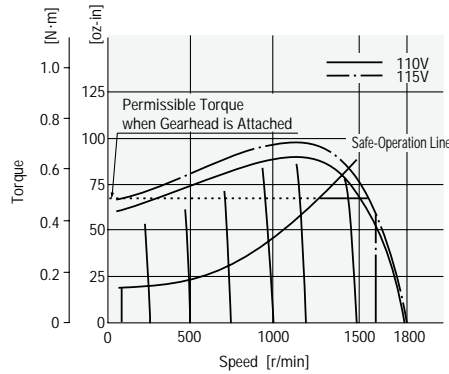

Single-Phase 220V/230V

SC206-402WE
SC206-002WE

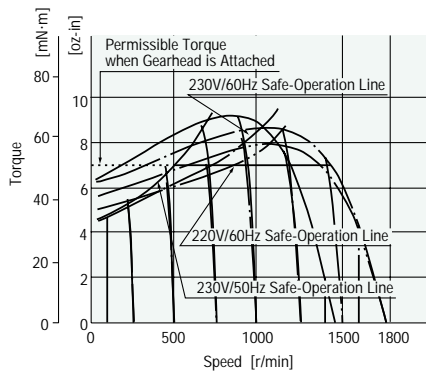

SC315-402WE
SC315-002WE

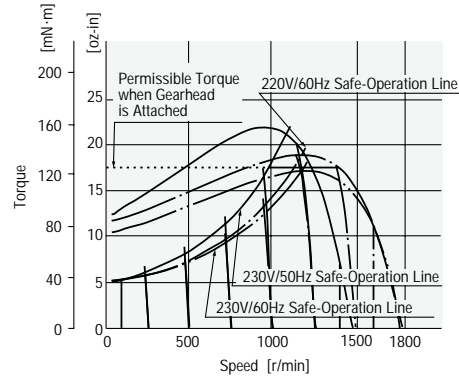

SC425-402WE
SC425-002WE

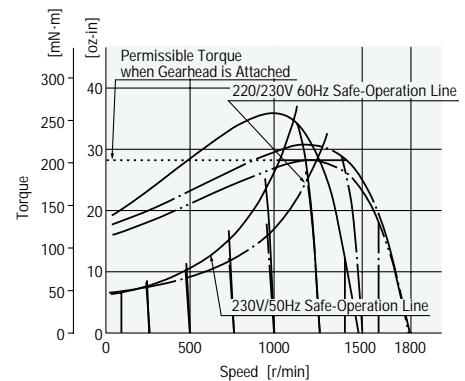

SC540-402WE
SC540-002WE

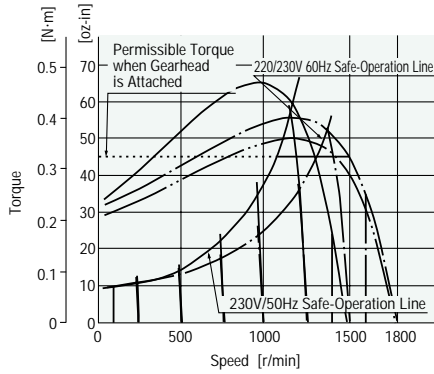

SC560-502WE
SC560-002WE

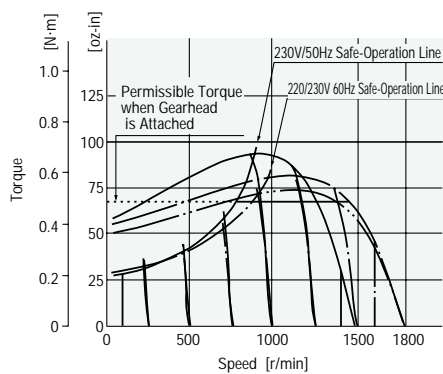

● **Reversible Motors**
Single-Phase 110V/115V
SC206-411WU
SC206-011WU

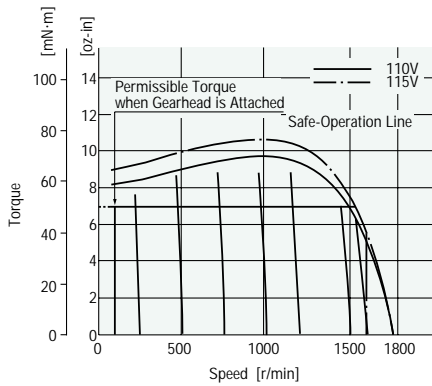

SC315-411WU
SC315-011WU

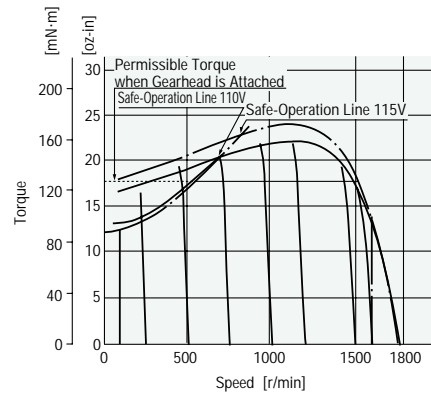

SC425-411WU
SC425-011WU

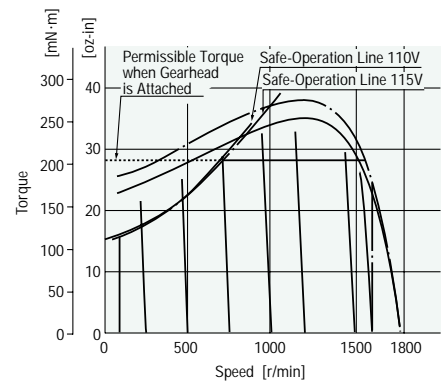

SC540-411WU
SC540-011WU

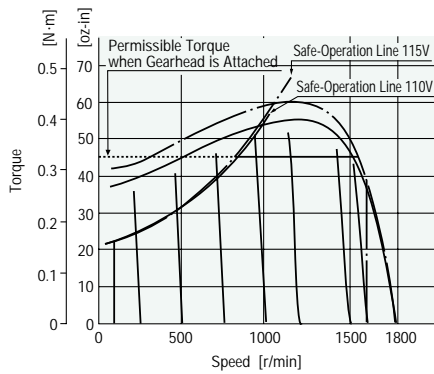

SC560-511WU
SC560-011WU

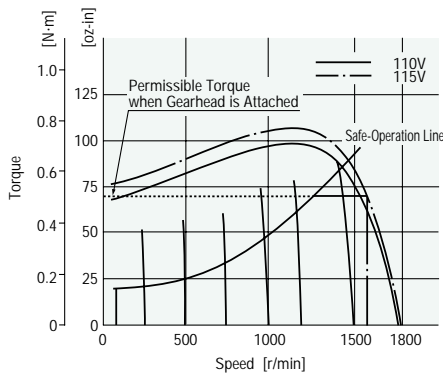

Single-Phase 220V/230V

SC206-412WE

SC206-012WE

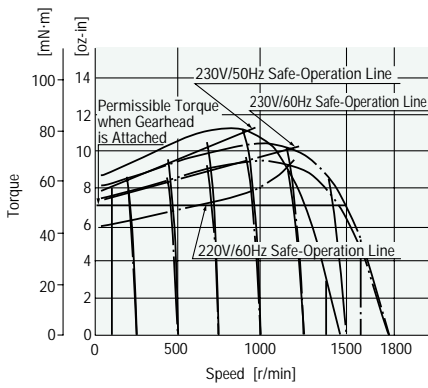

SC315-412WE

SC315-012WE

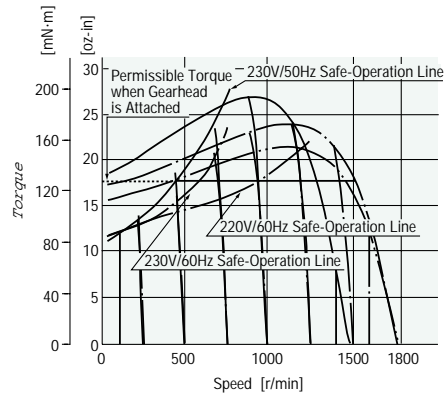

SC425-412WE

SC425-012WE

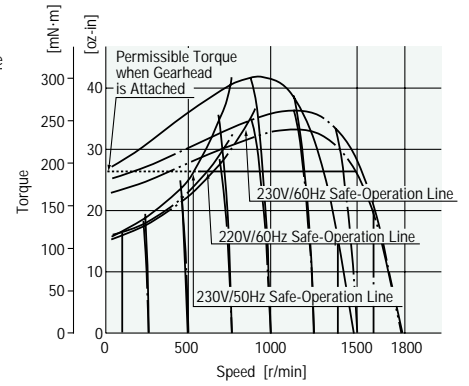

SC540-412WE

SC540-012WE

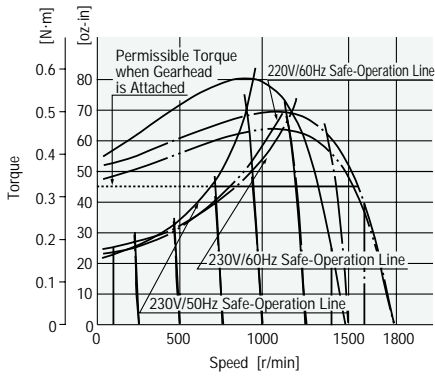

SC560-512WE

SC560-012WE

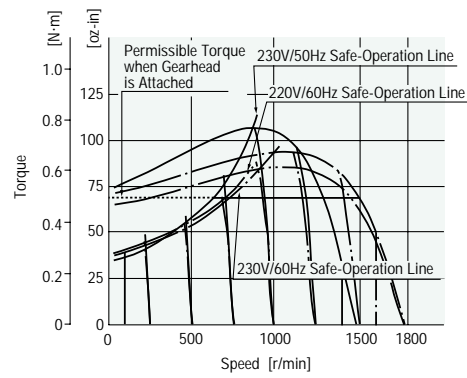

■ Wiring Diagrams

● Induction Motor

Uni-directional Operation, Speed Control

● 6W, 15W, 25W, 40W type

Speed

Control Pack

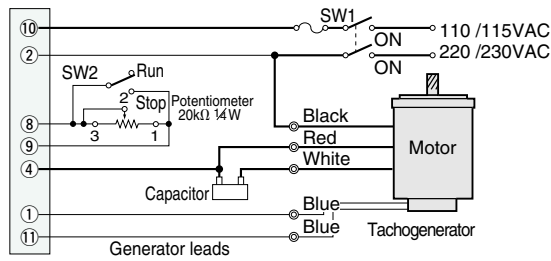

● Operation Chart

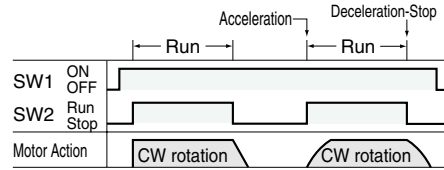

Run/Stop

Motor rotates at a speed set on the external speed potentiometer when switch SW2 is flipped to RUN (open). When SW2 is flipped to STOP (short circuit), the motor stops (natural stop).

Direction of Rotation

These wiring diagrams refer to clockwise (CW) rotation as viewed from the front shaft end of the motor. To rotate the motor in a counterclockwise (CCW) direction, reverse the red and white wires.

Run (Acceleration)/Stop (Deceleration)

To operate or stop the motor, use switch SW2. When SW2 is flipped to RUN (open), the motor accelerates to the speed set on the external speed potentiometer. When SW2 is flipped to STOP (short circuit), the motor decelerates to a stop.

Switch No	Specifications
SW1	125VAC, 5A Min or 250VAC, 5A Min
SW2	DC20V 10mA

Note: The direction of rotation should not be reversed when the power supply is first turned on.

● 60W type

Speed

Control Pack

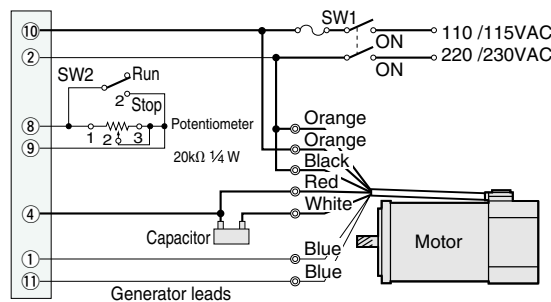

● Reversible Motors

Bi-directional Operation, Speed Control

● 6W, 15W, 25W, 40W type

Speed

Control Pack

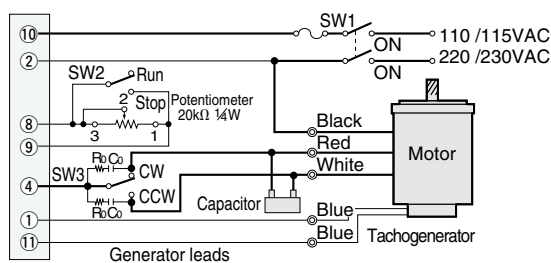

● Operation Chart

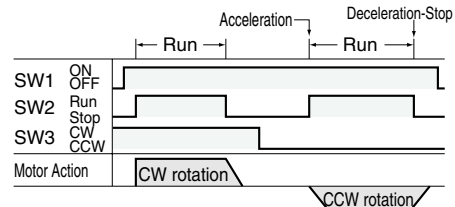

Run/Stop

Motor rotates at a speed set on the external speed potentiometer when switch SW2 is flipped to RUN (open). When SW2 is flipped to STOP (short circuit), the motor stops (natural stop).

Direction of Rotation

To rotate the motor in a clockwise (CW) direction, flip switch SW3 to CW. To rotate it in a counterclockwise (CCW) direction, flip SW3 to CCW. The direction of rotation is as viewed from the shaft end of the motor.

Run (Acceleration)/Stop (Deceleration)

To operate or stop the motor, use switch SW2. When SW2 is flipped to RUN (open), the motor accelerates to the speed set on the external speed potentiometer. When SW2 is flipped to STOP (short circuit), the motor decelerates to a stop.

Acceleration time and deceleration time are set with the built-in timing potentiometer located on the front surface.

Switch No	Specifications	Note
SW1	125VAC 5A Min or 250VAC 5A Min	—
SW2	DC20V 10mA	—
SW3	125VAC 5A Min or 250VAC 5A Min	—
Ro · Co	Ro=5~200 Ω	Accessory
Surge Suppressor	Co=0.1~0.2μ F 200WV (400WV)	EPCR1201-2

Note: The direction of rotation should not be reversed when the power supply is first turned on.

Speed Control

Setting Speed Using External Speed Potentiometer

The changes in speed are caused by resistance values. These changes are shown on the graph. In actual use, the circuit error and the error in the voltage produced by rate generator may cause an error in the set speed of $\pm 10\%$

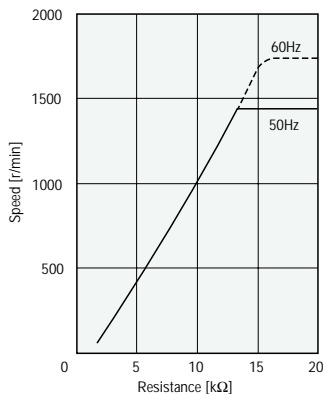

Speed Potentiometer Resistance-Value Speed Characteristics

Speed Control by External DC Control Voltage

The following figures show the connection for speed control using an external DC control voltage.

When using this method, make certain that the DC power supply is isolated from the AC input of the motor.

For SELV Circuit

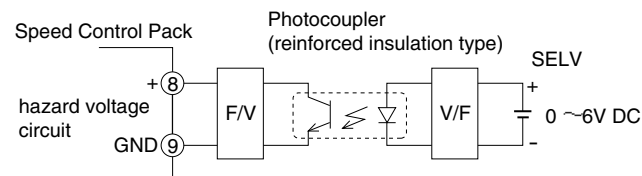

For Non-SELV Circuit

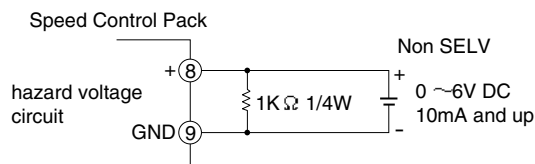

Note:

- Speed setting input terminals (8) and (9) are not insulated from dangerous voltages. You must use a reinforced isolation system between the speed control pack and a SELV circuit*.
- Check that the DC power supply comes from an AC power supply through a transformer and is insulated.
- *A SELV (Safety Extra Low Voltage) circuit (Max. DC60V or 42.4V peak) is isolated by reinforced insulation from hazardous voltage.

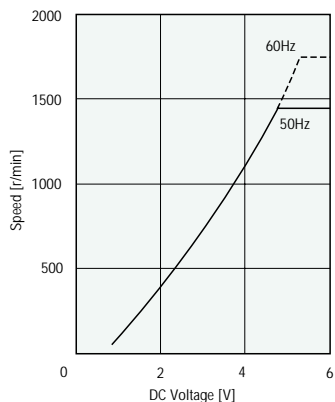

Speed Setting Voltage-Speed Characteristics

Installing the Speed Control Pack

Installing the Speed Control Pack

Use the flush mounting socket to install the control pack. The protection class of the flush mounting socket is IP10. When adjusting the acceleration/deceleration time with the power on, install an insulation cover to prevent touching the terminal connections as shown in the diagram below.

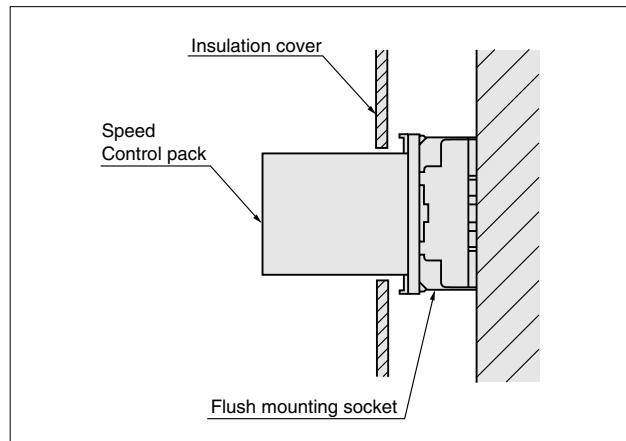

Acceleration / Deceleration Function

The **SC** Series has a special function allowing slow linear acceleration from start to operating speed and slow linear deceleration from the operating speed down to zero.

This makes it possible to prevent shock to the load and to accelerate/decelerate smoothly.

The desired values for acceleration and deceleration can be set independently using the built-in timing potentiometers on the top of the speed control pack.

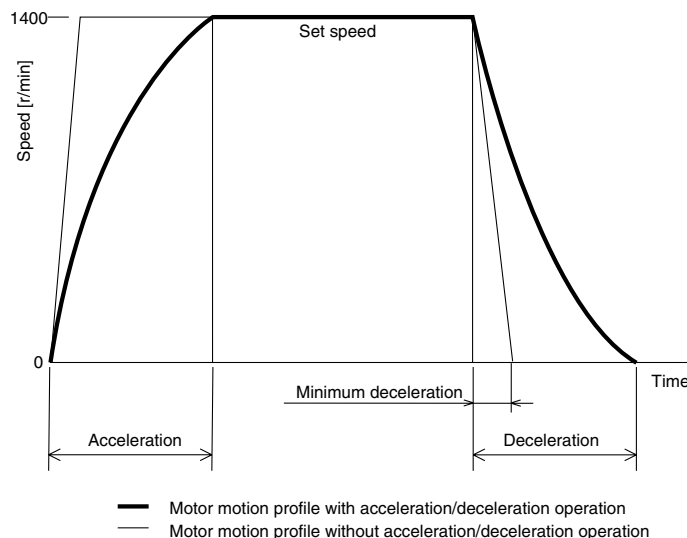

Turning the dial in a clockwise direction extends the acceleration/deceleration time. Acceleration and deceleration time can be adjusted within a range of 2 to 10 seconds. The dials are set to 0 before being shipped from the factory. Set the dial to 0 when not performing acceleration/deceleration operation.

Note: Use an insulated miniature screwdriver for adjusting the timing potentiometers.

■ List of Motor and Speed Control Pack Combination

● Induction Motors Single-Phase 110V/115V

Unit Model	Motor Model	Control Pack Model
SC206-401WU	MSM206-401W	SSP-1
SC206-001WU	MSM206-001W	
SC315-401WU	MSM315-401W	
SC315-001WU	MSM315-001W	
SC425-401WU	MSM425-401W	
SC425-001WU	MSM425-001W	
SC540-401WU	MSM540-401W	
SC540-001WU	MSM540-001W	
SC560-501WU	MSM560-501W	
SC560-001WU	MSM560-001W	

● Induction Motors Single-Phase 220V/230V

Unit Model	Motor Model	Control Pack Model
SC206-402WE	MSM206-402W	SSP-2
SC206-002WE	MSM206-002W	
SC315-402WE	MSM315-402W	
SC315-002WE	MSM315-002W	
SC425-402WE	MSM425-402W	
SC425-002WE	MSM425-002W	
SC540-402WE	MSM540-402W	
SC540-002WE	MSM540-002W	
SC560-502WE	MSM560-502W	
SC560-002WE	MSM560-002W	

● Reversible Motors Single-Phase 110V/115V

Unit Model	Motor Model	Control Pack Model
SC206-411WU	MSM206-411W	SSP-1
SC206-011WU	MSM206-011W	
SC315-411WU	MSM315-411W	
SC315-011WU	MSM315-011W	
SC425-411WU	MSM425-411W	
SC425-011WU	MSM425-011W	
SC540-411WU	MSM540-411W	
SC540-011WU	MSM540-011W	
SC560-511WU	MSM560-511W	
SC560-011WU	MSM560-011W	

● Reversible Motors Single-Phase 220V/230V

Unit Model	Motor Model	Control Pack Model
SC206-412WE	MSM206-412W	SSP-2
SC206-012WE	MSM206-012W	
SC315-412WE	MSM315-412W	
SC315-012WE	MSM315-012W	
SC425-412WE	MSM425-412W	
SC425-012WE	MSM425-012W	
SC540-412WE	MSM540-412W	
SC540-012WE	MSM540-012W	
SC560-512WE	MSM560-512W	
SC560-012WE	MSM560-012W	

■ Dimensions Scale 1/4, Unit= inch (mm)

SC206-4□1WU (Pinion shaft)

SC206-4□2WE

Motor

MSM206-4 □1W

MSM206-4 □2W

Weight (Mass) : 1.8 lb. (0.8kg)

Gearhead

2GN□KA (sold separately)

Weight (Mass) : 0.88 lb. (0.4kg)

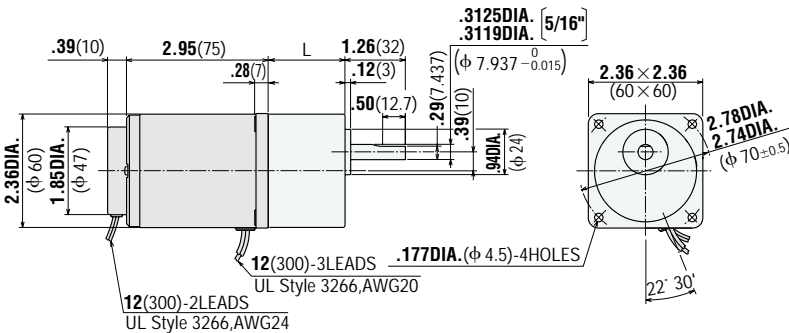

L=1.18(30) **2GN3KA~18KA**

L=1.57(40) **2GN25KA~180KA**

● Round shaft Type

SC206-0□1WU

SC206-0□2WE

Weight (Mass) : 1.8 lb. (0.8kg)

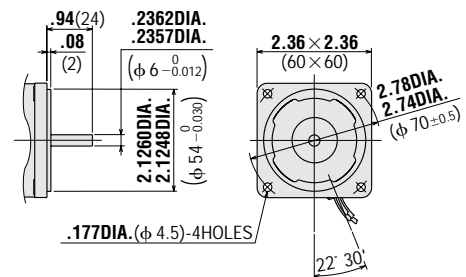

SC315-4 □ **1WU** (Pinion shaft)

SC315-4 □ **2WE**

Motor

MSM315-4 □ **1W**

MSM315-4 □ **2W**

Weight (Mass): 2.6 lb. (1.2kg)

Gearhead

3GN □ **KA**

Weight (Mass): 1.21 lb. (0.55kg)

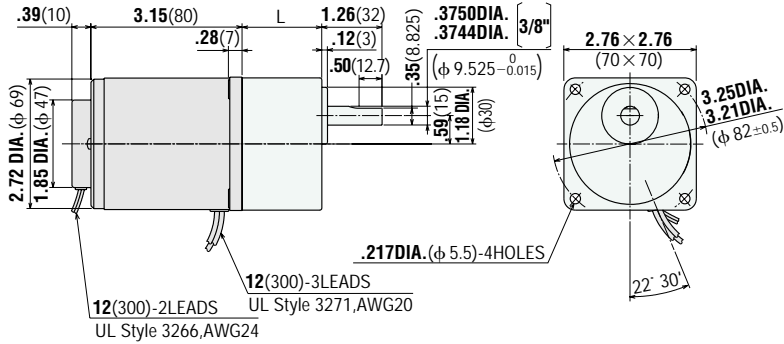

L=1.26(32) **3GN3KA ~ 18KA**

L=1.65(42) **3GN25KA ~ 180KA**

SC425-4 □ **1WU** (Pinion shaft)

SC425-4 □ **2WE**

Motor

MSM425-4 □ **1W**

MSM425-4 □ **2W**

Weight (Mass): 3.5 lb. (1.6kg)

Gearhead

4GN □ **KA**

Weight (Mass): 1.43 lb. (0.65kg)

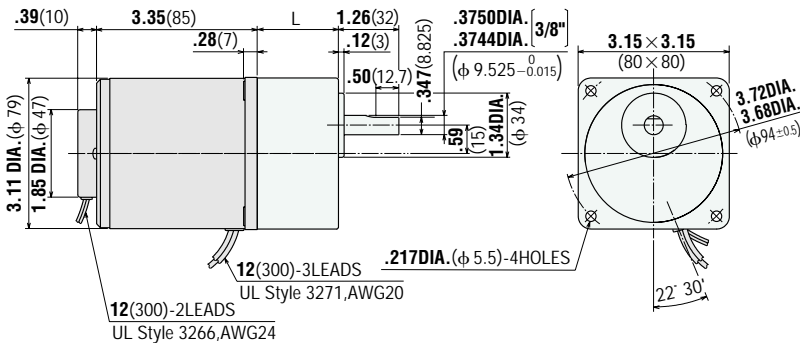

L=1.26(32) **4GN3KA ~ 18KA**

L=1.67(42.5) **4GN25KA ~ 180KA**

SC540-4 □ **1WU** (Pinion shaft)

SC540-4 □ **2WE**

Motor

MSM540-4 □ **1W**

MSM540-4 □ **2W**

Weight (Mass): 5.7 lb. (2.6kg)

Gearhead

5GN □ **KA**

Weight (Mass): 3.3 lb. (1.5kg)

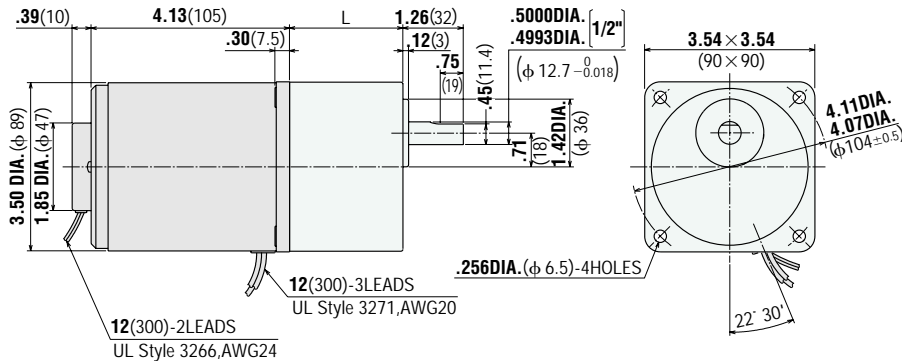

L=1.65(42) **5GN3KA ~ 18KA**

L=2.36(60) **5GN25KA ~ 180KA**

● Round shaft Type

SC315-0 □ **1WU**

SC315-0 □ **2WE**

Weight (Mass): 2.6 lb. (1.2kg)

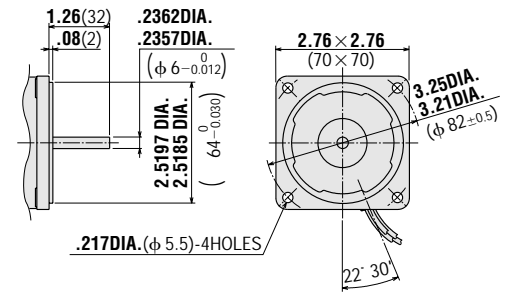

● Round shaft Type

SC425-0 □ **1WU**

SC425-0 □ **2WE**

Weight (Mass): 3.5 lb. (1.6kg)

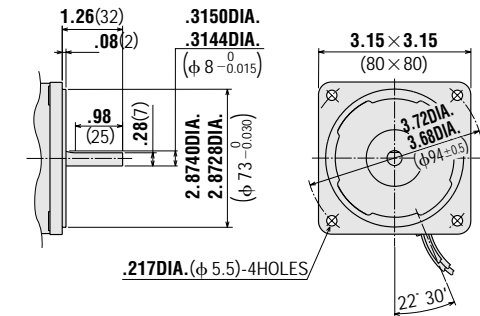

● Round Shaft Type

SC540-0 □ **1WU**

SC540-0 □ **2WE**

Weight (Mass): 5.7 lb. (2.6kg)

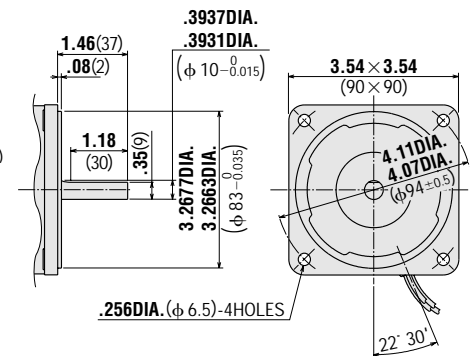

SC560-5□1WU (Pinion shaft)

SC560-5□2WE

Motor
MSM560-5□1W / **5GU□KA**
MSM560-5□2W / **5GU□KA**
Weight (Mass): 3.3 lb. (1.5kg)
Weight (Mass): 7.1 lb. (3.2kg)

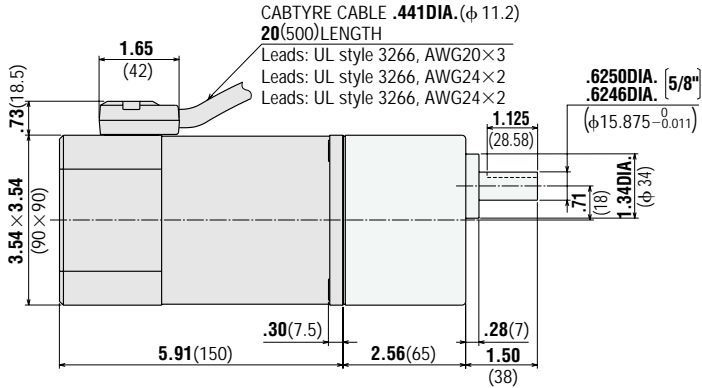

● **Round Shaft Type**

SC560-0□1WU

SC560-0□2WE

Weight (Mass): 7.1 lb. (3.2kg)

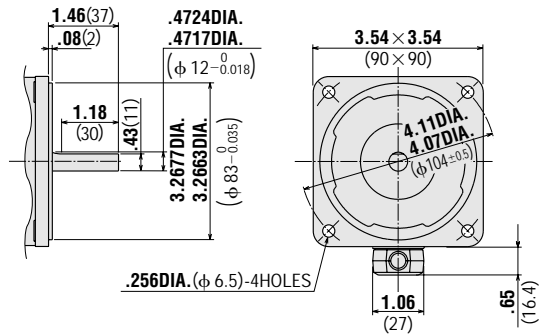

● **Key and Key Slot** (Scale 1/2)

The key is provided **5GU□KA** gearhead.

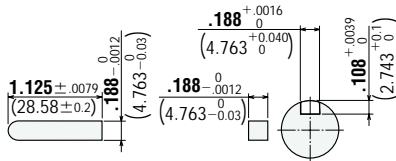

■ **Dimensions of Speed Control Pack** Scale 1/4, Unit = inch (mm)

Speed Control Pack SSP-1 Weight (Mass): 0.44 lb. (0.2kg)
SSP-2

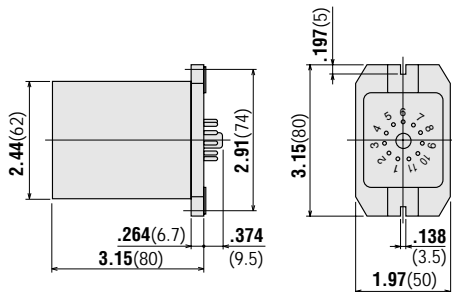

● **Flush Mounting Socket** (Provided with speed control pack)

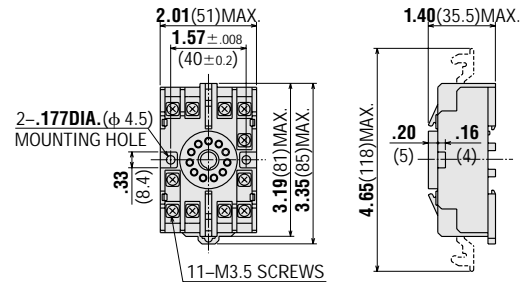

● **Potentiometer** (Provided with speed control pack)

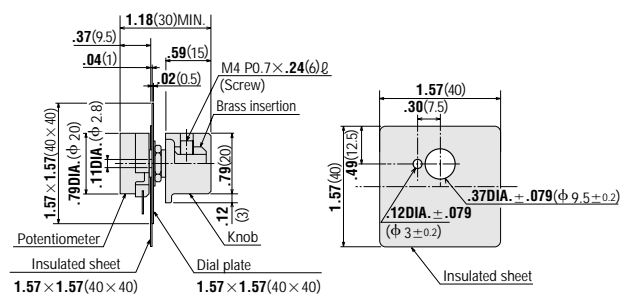

● **Capacitor** (included with the motor)

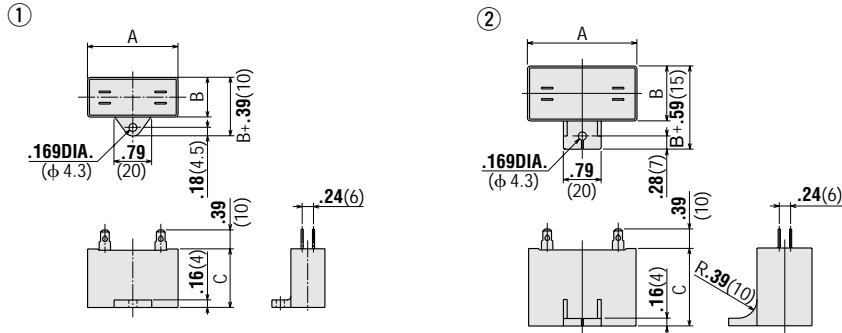

Dimensions

Unit = inch (mm)

Unit Model	Capacitor Model	A	B	C	Weight (Mass) oz (g)	Dimension No.	
SC206-401WU	SC206-001WU	CH25FAUL	1.22 (31)	0.67 (17)	1.06 (27)	0.71 (20)	
SC206-411WU	SC206-011WU	CH35FAUL	1.22 (31)	0.67 (17)	1.06 (27)	0.88 (25)	
SC315-401WU	SC315-001WU	CH45FAUL	1.46 (37)	0.71 (18)	1.06 (27)	1.06 (30)	
SC315-411WU	SC315-011WU	CH60CFAUL	1.50 (38)	0.83 (21)	1.22 (31)	1.41 (40)	①
SC425-401WU	SC425-001WU	CH65CFAUL	1.50 (38)	0.83 (21)	1.22 (31)	1.23 (35)	
SC425-411WU	SC425-011WU	CH80CFAUL	1.89 (48)	0.75 (19)	1.14 (29)	1.41 (40)	
SC540-401WU	SC540-001WU	CH90CFAUL	1.89 (48)	0.83 (21)	1.22 (31)	1.41 (40)	
SC540-411WU	SC540-011WU	CH120CFAUL	2.28 (58)	0.83 (21)	1.22 (31)	1.76 (50)	
SC560-501WU	SC560-001WU	CH180CFAUL	2.28 (58)	0.93 (23.5)	1.46 (37)	2.47 (70)	②
SC560-511WU	SC560-011WU	CH200CFAUL	2.28 (58)	1.14 (29)	1.61 (41)	3.35 (95)	
SC206-402WE	SC206-002WE	CH06BFAUL	1.22 (31)	0.57 (14.5)	0.93 (23.5)	0.53 (15)	
SC206-412WE	SC206-012WE	CH08BFAUL	1.22 (31)	0.67 (17)	1.06 (27)	0.88 (25)	
SC315-402WE	SC315-002WE	CH10BFAUL	1.46 (37)	0.71 (18)	1.06 (27)	1.06 (30)	
SC315-412WE	SC315-012WE	CH15BFAUL	1.50 (38)	0.83 (21)	1.22 (31)	1.23 (35)	①
SC425-402WE	SC425-002WE	CH15BFAUL	1.50 (38)	0.83 (21)	1.22 (31)	1.23 (35)	
SC425-412WE	SC425-012WE	CH20BFAUL	1.89 (48)	0.75 (19)	1.14 (29)	1.23 (35)	
SC540-402WE	SC540-002WE	CH23BFAUL	1.89 (48)	0.83 (21)	1.22 (31)	1.41 (40)	
SC540-412WE	SC540-012WE	CH35BFAUL	2.28 (58)	0.87 (22)	1.38 (35)	1.94 (55)	
SC560-502WE	SC560-002WE	CH40BFAUL	2.28 (58)	0.93 (23.5)	1.46 (37)	2.47 (70)	②
SC560-512WE	SC560-012WE	CH50BFAUL	2.28 (58)	1.14 (29)	1.61 (41)	3.00 (85)	

Capacitor cap is provided with the capacitor.

■ **Right-Angle Gearheads (sold separately)**

The right-angle gearhead provides an output shaft at a right angle to the motor's output shaft.

See page [A-216] for more information.

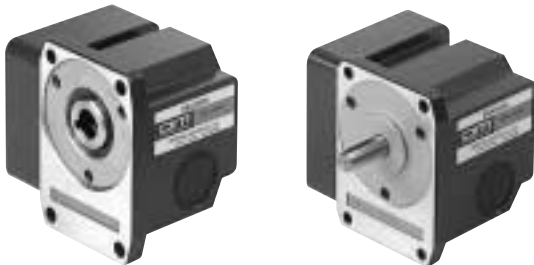

■ **Accessories (sold separately)**

● **Motor Mounting Brackets**

Optional die-cast aluminum mounting brackets are available. They can be used to install motors without gearheads.

See page [A-266] for more information.



● **Flexible Couplings**

Optional flexible couplings are available.

See page [A-260] for more information.

