

# Brushless Motors BLE Series

● Connection Information ●  
 Technical reference → Page G-1  
 Safety standards → Page H-2

The **BLE Series** sets a new standard for brushless motors by contributing to energy savings in a compact yet powerful package. By using the control module (sold separately), further improvements in performance and functions are possible. The electromagnetic brake option is ideal for vertical drive applications.



● For detailed product safety standard information including standards, file number and certification body, please visit [www.orientalmotor.com](http://www.orientalmotor.com).



## Features

### ● Speed Control Range of 100 to 4000 r/min and Speed Ratio of 40:1

Compared with conventional models, the speed control range of the **BLE Series** is greatly expanded.

Use in high-speed applications, even at the maximum speed of 4000 r/min, is possible.

Speed Control Range **BLE Series:** 100 to 4000 r/min (speed ratio 40:1)  
 Conventional Model: 300 to 3000 r/min (speed ratio 10:1)

[Comparison Using 120 W (1/6 HP) Output Model]

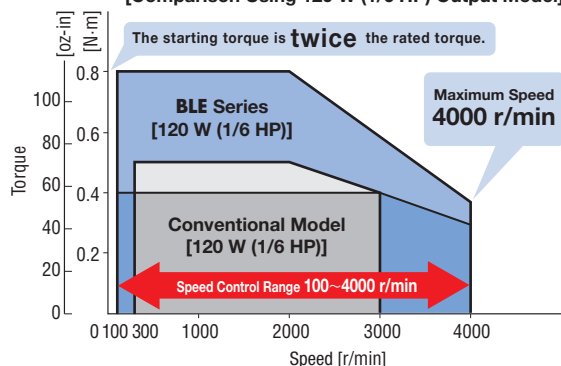

### ● Excellent Speed Stability

The speed regulation (load) is  $\pm 0.5\%$ .

For this reason, this mechanism ensures that the motor drives at a stable speed over its entire speed range from low to high, even when the load condition fluctuates.

[Conventional Model]	[BLE Series]
Load $-1\%$	Load $\pm 0.5\%$
Voltage $\pm 1\%$	Voltage $\pm 0.5\%$
Temperature $\pm 1\%$	Temperature $\pm 0.5\%$

### ● Energy Savings

Brushless motors use permanent magnets in the rotor. In comparison with an inverter-controlled motor, there is high efficiency and little loss, which means that energy savings is possible.

### ● Compact yet Powerful

In comparison with conventional models, high power is achieved with a slim body, efficient gearhead and lightweight size allowing for additional space savings.

[BLE Series 120 W (1/6 HP)]  
 Mass: 3.0 kg (6.6 lb.)

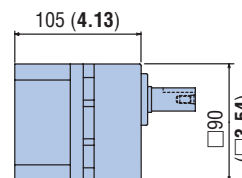

### ● Features of Gearheads

#### ◇ Long Life Gearhead Rated Life of 10000 Hours

The rated life of the parallel shaft gearhead and hollow shaft flat gearhead is 10000 hours. The parallel shaft gearhead achieves a long life that is twice as long as that of a conventional model.

● The parallel shaft gearhead for 60 W (1/12 HP) and 120 W (1/6 HP) models has a tapped hole at the shaft end.

#### ◇ Space Saving is Achieved with a Hollow Shaft Flat Gearhead

Direct connection to the drive shaft is possible without using a coupling, which enables equipment space saving.

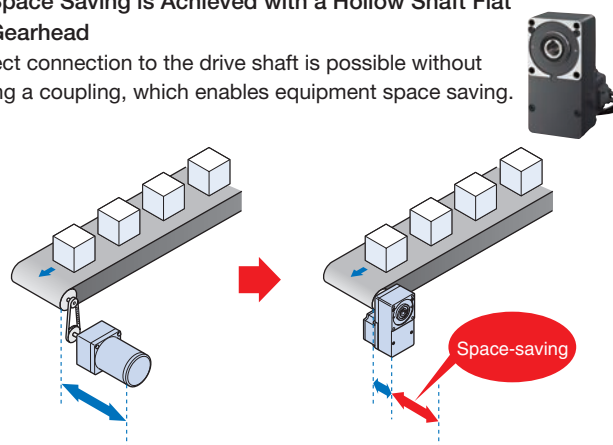

[For Three-Phase Motor and Parallel Shaft Gearhead]

[For Brushless Motor and Hollow Shaft Flat Gearhead]

# Brushless Motors/AC Speed Control Motors

## ● Use of Control Module Extends Specifications and Functions

Use in combination with a control module (sold separately) extends specifications and functions and makes the following possible:



● Control Module **OPX-2A** (Sold separately) ● Data Setting Software **MEXE02** (Sold separately)

Functions	-Various Displaying Functions: Operating Speed (Setting of gear ratio and speed increasing ratio), Conveyor Transportation Speed, Load Factor, Alarm Code, Alarm History, Warning Code, Warning History, I/O Monitor
	-Speed (8 speeds max.) -Torque Limiting Function -I/O Signal Assignment Change and Extension -Test Operation -Data Copy

## ◇ Expansion of Speed Control Range to 80 to 4000 r/min

The digital speed setting function expands the speed control range to cover 80 to 4000 r/min (speed ratio 50:1).

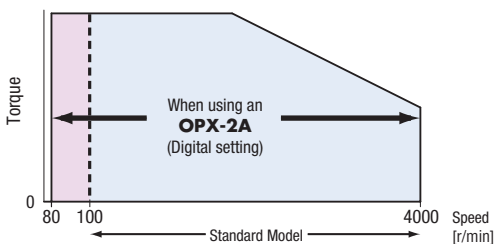

## ◇ Improved Speed Control Accuracy

[BLE Series]	[When using control module*]
Load $\pm 0.5\%$	Load $\pm 0.2\%$
Voltage $\pm 0.5\%$	Voltage $\pm 0.2\%$
Temperature $\pm 0.5\%$	Temperature $\pm 0.2\%$

\*When digital speed setting is used

## ◇ Multi-Speed Operation up to 8 Speeds is Possible

Using the control module (sold separately), multi-speed operation up to 8 speeds is possible. Speed setting in 1 r/min units as well as separate setting of the acceleration and deceleration time are also possible.

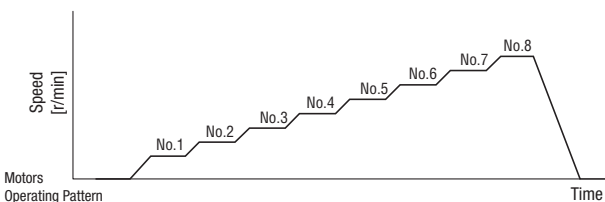

## ◇ Limiting the Motor Output Torque

The motor output torque can be suppressed in accordance with the application and use condition.

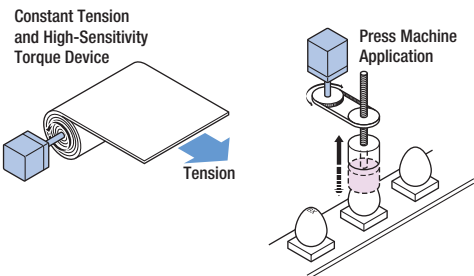

## ◇ Various Digital Displays are Possible (OPX-2A)

Speed, load factor, alarm code, etc. can be displayed digitally.

● The speed can be displayed as the speed of the gearhead output shaft.

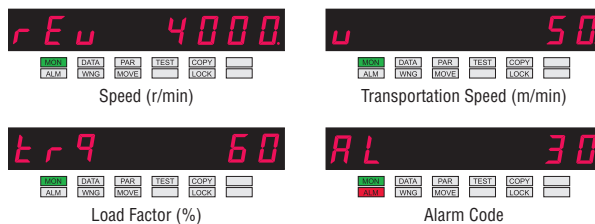

## ● Speed Control during Vertical Drive

The motor with an electromagnetic brake enables stable speed control even during vertical drive (gravitational operation). When the power is turned off, the motor stops instantaneously to hold the load in place. The electromagnetic brake is automatically controlled via the driver in accordance with ON/OFF of the operation command signal.

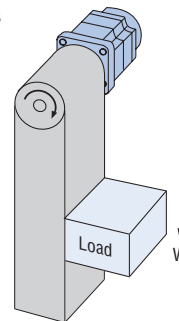

### Note

● Regeneration energy generates during vertical drive. If the BLE Series will be used in applications that require vertical drive, be sure to use a regeneration unit (sold separately).

## ● Cable Accessory

A 3 m (9.8 ft.) cable is included for connecting the motor and the driver.

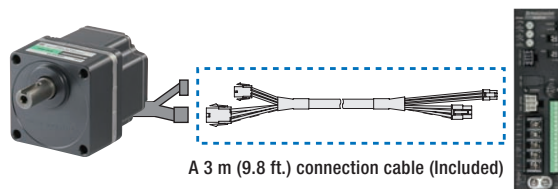

A 3 m (9.8 ft.) connection cable (Included)

## ● Select the Cable Length or a Flexible Connection Cable

### ◇ Cables up to 20 m (65.6 ft.) are Available (Sold separately)

When the distance between the motor and the driver is extended, the accessory (sold separately) connection cable must be used. The distance between the motor and the driver can be extended up to 20 m (65.6 ft.).

● Connection cables → Page D-228

### ◇ Flexible Connection Cables are Also Available (Sold separately)

Use a flexible connection cable if the cable will be bent.

● Flexible connection cables → Page D-228

System Configuration

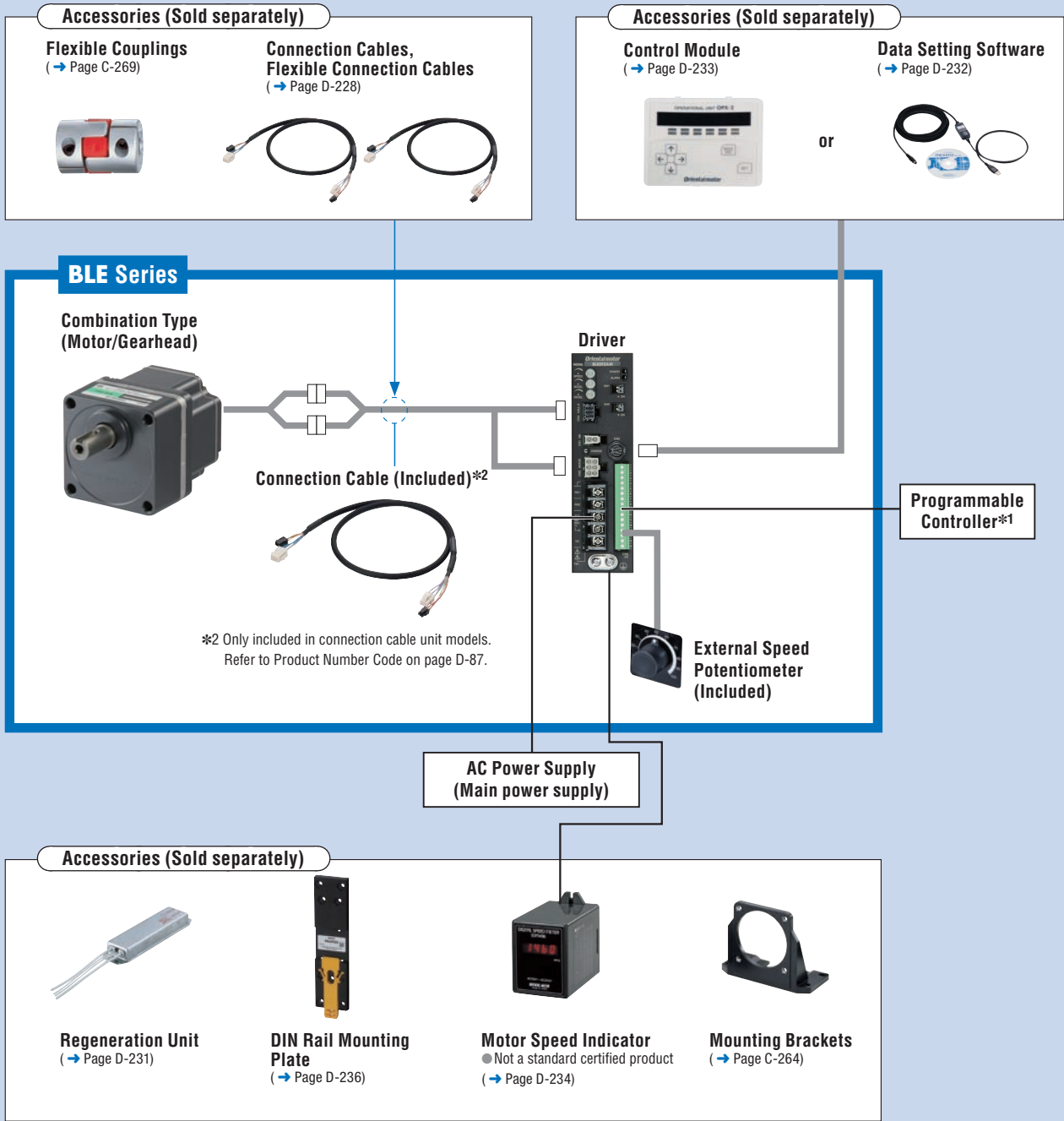

●Example of System Configuration

<b>BLE Series</b> Combination Type- Parallel Shaft <b>BLE46C50S-3</b>	+	<b>Sold Separately</b>			
		Connection Cable 7 m (23.0 ft.) <b>CC07BLE</b>	DIN Rail Mounting Plate <b>PADP03</b>	Mounting Bracket <b>SOL4M6</b>	Flexible Coupling <b>MCL515F10</b>

●The system configuration shown above is an example. Other combinations are available.

\*1 Not supplied

## Product Number Code

# BLE 5 12 A M 200 F - 3

①    ②    ③    ④    ⑤    ⑥    ⑦    ⑧

①	Series	<b>BLE: BLE</b> Series
②	Motor Frame Size	<b>2:</b> 60 mm (2.36 in.) <b>4:</b> 80 mm (3.15 in.) <b>5:</b> 90 mm (3.54 in.)
③	Output Power (W)	<b>3:</b> 30 W (1/25 HP) <b>6:</b> 60 W (1/12 HP) <b>12:</b> 120 W (1/6 HP)
④	Power Supply Voltage	<b>A:</b> Single-Phase 100-120 VAC <b>C:</b> Single-Phase 200-240 VAC <b>S:</b> Three-Phase 200-240 VAC
⑤	<b>M:</b> With Electromagnetic Brake Type	None: Standard type
⑥	Gear Ratio, Motor Shaft Type	Number: Gear Ratio for Combination Types: 8 types from <b>5</b> to <b>200</b> <b>A:</b> Round Shaft Type
⑦	Gearhead Type (Combination type only)	<b>S:</b> Parallel Shaft Gearhead <b>F:</b> Hollow Shaft Flat Gearhead
⑧	Connection Cable	<b>3:</b> The length of the connection cable is <b>3:</b> 3 m (9.8 ft.) None: No connection cable is included

- Examples with and without connection cables and showing the cable length.  
A 3 m (9.8 ft.) connection cable is included → **BLE512AM200F-3**  
No connection cable → **BLE512AM200F**

## Product Line

**Combination Type** The combination type comes with the motor and its dedicated gearhead pre-assembled which simplifies installation in equipment. Motors and gearheads are also available separately to facilitate changes or repairs.

### ● Standard Type

#### ◇ Combination Type – Parallel Shaft Gearhead

Output Power	Power Supply Voltage	Model	Gear Ratio
30 W (1/25 HP)	Single-Phase 100-120 VAC	<b>BLE23A□S-3</b> <b>BLE23A□S</b>	<b>5, 10, 15, 20, 30,</b> <b>50, 100, 200</b>
	Single-Phase 200-240 VAC	<b>BLE23C□S-3</b> <b>BLE23C□S</b>	<b>5, 10, 15, 20, 30,</b> <b>50, 100, 200</b>
	Three-Phase 200-240 VAC	<b>BLE23S□S-3</b> <b>BLE23S□S</b>	<b>5, 10, 15, 20, 30,</b> <b>50, 100, 200</b>
60 W (1/12 HP)	Single-Phase 100-120 VAC	<b>BLE46A□S-3</b> <b>BLE46A□S</b>	<b>5, 10, 15, 20, 30,</b> <b>50, 100, 200</b>
	Single-Phase 200-240 VAC	<b>BLE46C□S-3</b> <b>BLE46C□S</b>	<b>5, 10, 15, 20, 30,</b> <b>50, 100, 200</b>
	Three-Phase 200-240 VAC	<b>BLE46S□S-3</b> <b>BLE46S□S</b>	<b>5, 10, 15, 20, 30,</b> <b>50, 100, 200</b>
120 W (1/6 HP)	Single-Phase 100-120 VAC	<b>BLE512A□S-3</b> <b>BLE512A□S</b>	<b>5, 10, 15, 20, 30,</b> <b>50, 100, 200</b>
	Single-Phase 200-240 VAC	<b>BLE512C□S-3</b> <b>BLE512C□S</b>	<b>5, 10, 15, 20, 30,</b> <b>50, 100, 200</b>
	Three-Phase 200-240 VAC	<b>BLE512S□S-3</b> <b>BLE512S□S</b>	<b>5, 10, 15, 20, 30,</b> <b>50, 100, 200</b>

The following items are included in each product.  
Motor, Driver, Gearhead, Connection Cable\*, External Speed Potentiometer (With signal line), Mounting Screws, Parallel Key, Operating Manual  
\* Only for models with a connection cable included.

- When the distance between the motor and the driver is extended, the accessory (sold separately) connection cable or flexible connection cable must be used. Cables → Page D-228

#### ◇ Round Shaft Type

Output Power	Power Supply Voltage	Model
30 W (1/25 HP)	Single-Phase 100-120 VAC	<b>BLE23AA-3</b> <b>BLE23AA</b>
	Single-Phase 200-240 VAC	<b>BLE23CA-3</b> <b>BLE23CA</b>
	Three-Phase 200-240 VAC	<b>BLE23SA-3</b> <b>BLE23SA</b>
60 W (1/12 HP)	Single-Phase 100-120 VAC	<b>BLE46AA-3</b> <b>BLE46AA</b>
	Single-Phase 200-240 VAC	<b>BLE46CA-3</b> <b>BLE46CA</b>
	Three-Phase 200-240 VAC	<b>BLE46SA-3</b> <b>BLE46SA</b>

#### ◇ Combination Type – Hollow Shaft Flat Gearhead

Output Power	Power Supply Voltage	Model	Gear Ratio
30 W (1/25 HP)	Single-Phase 100-120 VAC	<b>BLE23A□F-3</b> <b>BLE23A□F</b>	<b>5, 10, 15, 20, 30,</b> <b>50, 100, 200</b>
	Single-Phase 200-240 VAC	<b>BLE23C□F-3</b> <b>BLE23C□F</b>	<b>5, 10, 15, 20, 30,</b> <b>50, 100, 200</b>
	Three-Phase 200-240 VAC	<b>BLE23S□F-3</b> <b>BLE23S□F</b>	<b>5, 10, 15, 20, 30,</b> <b>50, 100, 200</b>
60 W (1/12 HP)	Single-Phase 100-120 VAC	<b>BLE46A□F-3</b> <b>BLE46A□F</b>	<b>5, 10, 15, 20, 30,</b> <b>50, 100, 200</b>
	Single-Phase 200-240 VAC	<b>BLE46C□F-3</b> <b>BLE46C□F</b>	<b>5, 10, 15, 20, 30,</b> <b>50, 100, 200</b>
	Three-Phase 200-240 VAC	<b>BLE46S□F-3</b> <b>BLE46S□F</b>	<b>5, 10, 15, 20, 30,</b> <b>50, 100, 200</b>
120 W (1/6 HP)	Single-Phase 100-120 VAC	<b>BLE512A□F-3</b> <b>BLE512A□F</b>	<b>5, 10, 15, 20, 30,</b> <b>50, 100, 200</b>
	Single-Phase 200-240 VAC	<b>BLE512C□F-3</b> <b>BLE512C□F</b>	<b>5, 10, 15, 20, 30,</b> <b>50, 100, 200</b>
	Three-Phase 200-240 VAC	<b>BLE512S□F-3</b> <b>BLE512S□F</b>	<b>5, 10, 15, 20, 30,</b> <b>50, 100, 200</b>

The following items are included in each product.  
Motor, Driver, Gearhead, Connection Cable\*, External Speed Potentiometer (With signal line), Mounting Screws, Parallel Key, Safety Cover (Screws included), Operating Manual  
\* Only for models with a connection cable included.

- When the distance between the motor and the driver is extended, the accessory (sold separately) connection cable or flexible connection cable must be used. Cables → Page D-228

Output Power	Power Supply Voltage	Model
120 W (1/6 HP)	Single-Phase 100-120 VAC	<b>BLE512AA-3</b> <b>BLE512AA</b>
	Single-Phase 200-240 VAC	<b>BLE512CA-3</b> <b>BLE512CA</b>
	Three-Phase 200-240 VAC	<b>BLE512SA-3</b> <b>BLE512SA</b>

The following items are included in each product.  
Motor, Driver, Connection Cable\*, External Speed Potentiometer (Signal line included), Operating Manual  
\* Only for models with a connection cable included.

- When the distance between the motor and the driver is extended, the accessory (sold separately) connection cable or flexible connection cable must be used. Cables → Page D-228

- Enter the gear ratio in the box (□) within the model name.

## ● With Electromagnetic Brake Type

### ◇ Combination Type – Parallel Shaft Gearhead

Output Power	Power Supply Voltage	Model	Gear Ratio
30 W (1/25 HP)	Single-Phase 100-120 VAC	<b>BLE23AM</b> □S-3 <b>BLE23AM</b> □S	<b>5, 10, 15, 20, 30, 50, 100, 200</b>
	Single-Phase 200-240 VAC	<b>BLE23CM</b> □S-3 <b>BLE23CM</b> □S	<b>5, 10, 15, 20, 30, 50, 100, 200</b>
	Three-Phase 200-240 VAC	<b>BLE23SM</b> □S-3 <b>BLE23SM</b> □S	<b>5, 10, 15, 20, 30, 50, 100, 200</b>
60 W (1/12 HP)	Single-Phase 100-120 VAC	<b>BLE46AM</b> □S-3 <b>BLE46AM</b> □S	<b>5, 10, 15, 20, 30, 50, 100, 200</b>
	Single-Phase 200-240 VAC	<b>BLE46CM</b> □S-3 <b>BLE46CM</b> □S	<b>5, 10, 15, 20, 30, 50, 100, 200</b>
	Three-Phase 200-240 VAC	<b>BLE46SM</b> □S-3 <b>BLE46SM</b> □S	<b>5, 10, 15, 20, 30, 50, 100, 200</b>
120 W (1/6 HP)	Single-Phase 100-120 VAC	<b>BLE512AM</b> □S-3 <b>BLE512AM</b> □S	<b>5, 10, 15, 20, 30, 50, 100, 200</b>
	Single-Phase 200-240 VAC	<b>BLE512CM</b> □S-3 <b>BLE512CM</b> □S	<b>5, 10, 15, 20, 30, 50, 100, 200</b>
	Three-Phase 200-240 VAC	<b>BLE512SM</b> □S-3 <b>BLE512SM</b> □S	<b>5, 10, 15, 20, 30, 50, 100, 200</b>

The following items are included in each product.  
 Motor, Driver, Gearhead, Connection Cable\*, External Speed Potentiometer (With signal line), Mounting Screws, Parallel Key, Operating Manual  
 \* Only for models with a connection cable included.

● When the distance between the motor and the driver is extended, the accessory (sold separately) connection cable or flexible connection cable must be used. Cables → Page D-228

### ◇ Round Shaft Type

Output Power	Power Supply Voltage	Model
30 W (1/25 HP)	Single-Phase 100-120 VAC	<b>BLE23AMA-3</b> <b>BLE23AMA</b>
	Single-Phase 200-240 VAC	<b>BLE23CMA-3</b> <b>BLE23CMA</b>
	Three-Phase 200-240 VAC	<b>BLE23SMA-3</b> <b>BLE23SMA</b>
60 W (1/12 HP)	Single-Phase 100-120 VAC	<b>BLE46AMA-3</b> <b>BLE46AMA</b>
	Single-Phase 200-240 VAC	<b>BLE46CMA-3</b> <b>BLE46CMA</b>
	Three-Phase 200-240 VAC	<b>BLE46SMA-3</b> <b>BLE46SMA</b>
120 W (1/6 HP)	Single-Phase 100-120 VAC	<b>BLE512AMA-3</b> <b>BLE512AMA</b>
	Single-Phase 200-240 VAC	<b>BLE512CMA-3</b> <b>BLE512CMA</b>
	Three-Phase 200-240 VAC	<b>BLE512SMA-3</b> <b>BLE512SMA</b>

The following items are included in each product.  
 Motor, Driver, Connection Cable\*, External Speed Potentiometer (Signal line included), Operating Manual  
 \* Only for models with a connection cable included.

● When the distance between the motor and the driver is extended, the accessory (sold separately) connection cable or flexible connection cable must be used. Cables → Page D-228

### ◇ Combination Type – Hollow Shaft Flat Gearhead

Output Power	Power Supply Voltage	Model	Gear Ratio
30 W (1/25 HP)	Single-Phase 100-120 VAC	<b>BLE23AM</b> □F-3 <b>BLE23AM</b> □F	<b>5, 10, 15, 20, 30, 50, 100, 200</b>
	Single-Phase 200-240 VAC	<b>BLE23CM</b> □F-3 <b>BLE23CM</b> □F	<b>5, 10, 15, 20, 30, 50, 100, 200</b>
	Three-Phase 200-240 VAC	<b>BLE23SM</b> □F-3 <b>BLE23SM</b> □F	<b>5, 10, 15, 20, 30, 50, 100, 200</b>
60 W (1/12 HP)	Single-Phase 100-120 VAC	<b>BLE46AM</b> □F-3 <b>BLE46AM</b> □F	<b>5, 10, 15, 20, 30, 50, 100, 200</b>
	Single-Phase 200-240 VAC	<b>BLE46CM</b> □F-3 <b>BLE46CM</b> □F	<b>5, 10, 15, 20, 30, 50, 100, 200</b>
	Three-Phase 200-240 VAC	<b>BLE46SM</b> □F-3 <b>BLE46SM</b> □F	<b>5, 10, 15, 20, 30, 50, 100, 200</b>
120 W (1/6 HP)	Single-Phase 100-120 VAC	<b>BLE512AM</b> □F-3 <b>BLE512AM</b> □F	<b>5, 10, 15, 20, 30, 50, 100, 200</b>
	Single-Phase 200-240 VAC	<b>BLE512CM</b> □F-3 <b>BLE512CM</b> □F	<b>5, 10, 15, 20, 30, 50, 100, 200</b>
	Three-Phase 200-240 VAC	<b>BLE512SM</b> □F-3 <b>BLE512SM</b> □F	<b>5, 10, 15, 20, 30, 50, 100, 200</b>

The following items are included in each product.  
 Motor, Driver, Gearhead, Connection Cable\*, External Speed Potentiometer (With signal line), Mounting Screws, Parallel Key, Safety Cover (Screws included), Operating Manual  
 \* Only for models with a connection cable included.

● When the distance between the motor and the driver is extended, the accessory (sold separately) connection cable or flexible connection cable must be used. Cables → Page D-228

● Enter the gear ratio in the box (□) within the model name.

## Specifications

### Standard Type

◇ 30 W (1/25 HP) (RoHS)



Model	Combination Type – Parallel Shaft Gearhead		BLE23A□S-3, BLE23A□S	BLE23C□S-3, BLE23C□S	BLE23S□S-3, BLE23S□S
	Combination Type – Hollow Shaft Flat Gearhead		BLE23A□F-3, BLE23A□F	BLE23C□F-3, BLE23C□F	BLE23S□F-3, BLE23S□F
	Round Shaft Type		BLE23AA-3, BLE23AA	BLE23CA-3, BLE23CA	BLE23SA-3, BLE23SA
Rated Output Power (Continuous)		W (HP)	30 (1/25)		
Power Source	Rated Voltage	VAC	Single-Phase 100-120	Single-Phase 200-240	Three-Phase 200-240
	Permissible Voltage Range		-15~+10%		
	Rated Frequency	Hz	50/60		
	Permissible Frequency Range		±5%		
	Rated Input Current	A	1.3	0.8	0.45
Maximum Input Current		A	3.5	2.1	1.2
Rated Torque		N·m (oz·in)	0.1 (14.2)		
Starting Torque*1		N·m (oz·in)	0.2 (28)		
Rated Speed		r/min	3000		
Speed Control Range		r/min	100~4000 (Analog setting), 80~4000 (Digital setting can be set in 1 r/min increments)*2		
Round Shaft Type					
Permissible Load Inertia J		×10 <sup>-4</sup> kg·m <sup>2</sup> (oz·in <sup>2</sup> )	1.8 (9.8)		
Rotor Inertia J		×10 <sup>-4</sup> kg·m <sup>2</sup> (oz·in <sup>2</sup> )	0.087 (0.48)		
Speed Regulation	Load	±0.5% (±0.2%)*2 max. (0~Rated torque, at rated speed, at rated voltage, at normal ambient temperature)			
	Voltage	±0.5% (±0.2%)*2 max. (Rated voltage -15~+10%, at rated speed, with no load, at normal ambient temperature)			
	Temperature	±0.5% (±0.2%)*2 max. [0~+50°C (+32~+122°F), at rated speed, with no load, at rated voltage]			

◇ 60 W (1/12 HP) (RoHS)



Model	Combination Type – Parallel Shaft Gearhead		BLE46A□S-3, BLE46A□S	BLE46C□S-3, BLE46C□S	BLE46S□S-3, BLE46S□S
	Combination Type – Hollow Shaft Flat Gearhead		BLE46A□F-3, BLE46A□F	BLE46C□F-3, BLE46C□F	BLE46S□F-3, BLE46S□F
	Round Shaft Type		BLE46AA-3, BLE46AA	BLE46CA-3, BLE46CA	BLE46SA-3, BLE46SA
Rated Output Power (Continuous)		W (HP)	60 (1/12)		
Power Source	Rated Voltage	VAC	Single-Phase 100-120	Single-Phase 200-240	Three-Phase 200-240
	Permissible Voltage Range		-15~+10%		
	Rated Frequency	Hz	50/60		
	Permissible Frequency Range		±5%		
	Rated Input Current	A	2.0	1.2	0.7
Maximum Input Current		A	4.5	2.6	1.5
Rated Torque		N·m (oz·in)	0.2 (28)		
Starting Torque*1		N·m (oz·in)	0.4 (56)		
Rated Speed		r/min	3000		
Speed Control Range		r/min	100~4000 (Analog setting), 80~4000 (Digital setting can be set in 1 r/min increments)*2		
Round Shaft Type					
Permissible Load Inertia J		×10 <sup>-4</sup> kg·m <sup>2</sup> (oz·in <sup>2</sup> )	3.75 (21)		
Rotor Inertia J		×10 <sup>-4</sup> kg·m <sup>2</sup> (oz·in <sup>2</sup> )	0.24 (1.31)		
Speed Regulation	Load	±0.5% (±0.2%)*2 max. (0~Rated torque, at rated speed, at rated voltage, at normal ambient temperature)			
	Voltage	±0.5% (±0.2%)*2 max. (Rated voltage -15~+10%, at rated speed, with no load, at normal ambient temperature)			
	Temperature	±0.5% (±0.2%)*2 max. [0~+50°C (+32~+122°F), at rated speed, with no load, at rated voltage]			

◇ 120 W (1/6 HP) (RoHS)



Model	Combination Type – Parallel Shaft Gearhead		BLE512A□S-3, BLE512A□S	BLE512C□S-3, BLE512C□S	BLE512S□S-3, BLE512S□S
	Combination Type – Hollow Shaft Flat Gearhead		BLE512A□F-3, BLE512A□F	BLE512C□F-3, BLE512C□F	BLE512S□F-3, BLE512S□F
	Round Shaft Type		BLE512AA-3, BLE512AA	BLE512CA-3, BLE512CA	BLE512SA-3, BLE512SA
Rated Output Power (Continuous)		W (HP)	120 (1/6)		
Power Source	Rated Voltage	VAC	Single-Phase 100-120	Single-Phase 200-240	Three-Phase 200-240
	Permissible Voltage Range		-15~+10%		
	Rated Frequency	Hz	50/60		
	Permissible Frequency Range		±5%		
	Rated Input Current	A	3.3	2.0	1.2
Maximum Input Current		A	8.2	4.4	2.5
Rated Torque		N·m (oz·in)	0.4 (56)		
Starting Torque*1		N·m (oz·in)	0.8 (113)		
Rated Speed		r/min	3000		
Speed Control Range		r/min	100~4000 (Analog setting), 80~4000 (Digital setting can be set in 1 r/min increments)*2		
Round Shaft Type					
Permissible Load Inertia J		×10 <sup>-4</sup> kg·m <sup>2</sup> (oz·in <sup>2</sup> )	5.6 (31)		
Rotor Inertia J		×10 <sup>-4</sup> kg·m <sup>2</sup> (oz·in <sup>2</sup> )	0.61 (3.3)		
Speed Regulation	Load	±0.5% (±0.2%)*2 max. (0~Rated torque, at rated speed, at rated voltage, at normal ambient temperature)			
	Voltage	±0.5% (±0.2%)*2 max. (Rated voltage -15~+10%, at rated speed, with no load, at normal ambient temperature)			
	Temperature	±0.5% (±0.2%)*2 max. [0~+50°C (+32~+122°F), at rated speed, with no load, at rated voltage]			

\*1 The starting torque can be used a maximum duration of approximately five seconds.

\*2 These specifications apply when a control module (sold separately) is used.

- The values for each specification apply to the motor only.
- Enter the gear ratio in the box (□) within the model name.

## ● With Electromagnetic Brake Type

### ◇ 30 W (1/25 HP) (RoHS)



Model	Combination Type – Parallel Shaft Gearhead		<b>BLE23AM□S-3, BLE23AM□S</b>	<b>BLE23CM□S-3, BLE23CM□S</b>	<b>BLE23SM□S-3, BLE23SM□S</b>
	Combination Type – Hollow Shaft Flat Gearhead		<b>BLE23AM□F-3, BLE23AM□F</b>	<b>BLE23CM□F-3, BLE23CM□F</b>	<b>BLE23SM□F-3, BLE23SM□F</b>
	Round Shaft Type		<b>BLE23AMA-3, BLE23AMA</b>	<b>BLE23CMA-3, BLE23CMA</b>	<b>BLE23SMA-3, BLE23SMA</b>
Rated Output Power (Continuous)	W (HP)	30 (1/25)			
Power Source	Rated Voltage	VAC	Single-Phase 100-120	Single-Phase 200-240	Three-Phase 200-240
	Permissible Voltage Range		-15~+10%		
	Rated Frequency	Hz	50/60		
	Permissible Frequency Range		±5%		
	Rated Input Current	A	1.3	0.8	0.45
	Maximum Input Current	A	3.5	2.1	1.2
Rated Torque	N·m (oz-in)	0.1 (14.2)			
Starting Torque*1	N·m (oz-in)	0.2 (28)			
Rated Speed	r/min	3000			
Speed Control Range	r/min	100~4000 (Analog setting), 80~4000 (Digital setting can be set in 1 r/min increments)*2			
Round Shaft Type					
Permissible Load Inertia J	×10 <sup>-4</sup> kg·m <sup>2</sup> (oz-in <sup>2</sup> )	1.8 (9.8)			
Rotor Inertia J	×10 <sup>-4</sup> kg·m <sup>2</sup> (oz-in <sup>2</sup> )	0.087 (0.48)			
Speed Regulation	Load	±0.5% (±0.2%)*2 max. (0~Rated torque, at rated speed, at rated voltage, at normal ambient temperature)			
	Voltage	±0.5% (±0.2%)*2 max. (Rated voltage -15~+10%, at rated speed, with no load, at normal ambient temperature)			
	Temperature	±0.5% (±0.2%)*2 max. [0~+50°C (+32~+122°F), at rated speed, with no load, at rated voltage]			
Gravitational Operation Ability	Continuous Regenerative Power	W (HP)	100 (1/8)		
	Instantaneous Regenerative Power	W (HP)	240 (1/3)		
	Applicable Regeneration Unit*3		<b>EPRC-400P</b>		
Electromagnetic Brake*4	Brake Type	Active when the power is off, automatically controlled by the driver			
	Static Friction Torque	N·m (oz-in)	0.1 (14.2)		

### ◇ 60 W (1/12 HP) (RoHS)



Model	Combination Type – Parallel Shaft Gearhead		<b>BLE46AM□S-3, BLE46AM□S</b>	<b>BLE46CM□S-3, BLE46CM□S</b>	<b>BLE46SM□S-3, BLE46SM□S</b>
	Combination Type – Hollow Shaft Flat Gearhead		<b>BLE46AM□F-3, BLE46AM□F</b>	<b>BLE46CM□F-3, BLE46CM□F</b>	<b>BLE46SM□F-3, BLE46SM□F</b>
	Round Shaft Type		<b>BLE46AMA-3, BLE46AMA</b>	<b>BLE46CMA-3, BLE46CMA</b>	<b>BLE46SMA-3, BLE46SMA</b>
Rated Output Power (Continuous)	W (HP)	60 (1/12)			
Power Source	Rated Voltage	VAC	Single-Phase 100-120	Single-Phase 200-240	Three-Phase 200-240
	Permissible Voltage Range		-15~+10%		
	Rated Frequency	Hz	50/60		
	Permissible Frequency Range		±5%		
	Rated Input Current	A	2.0	1.2	0.7
	Maximum Input Current	A	4.5	2.6	1.5
Rated Torque	N·m (oz-in)	0.2 (28)			
Starting Torque*1	N·m (oz-in)	0.4 (56)			
Rated Speed	r/min	3000			
Speed Control Range	r/min	100~4000 (Analog setting), 80~4000 (Digital setting can be set in 1 r/min increments)*2			
Round Shaft Type					
Permissible Load Inertia J	×10 <sup>-4</sup> kg·m <sup>2</sup> (oz-in <sup>2</sup> )	3.75 (21)			
Rotor Inertia J	×10 <sup>-4</sup> kg·m <sup>2</sup> (oz-in <sup>2</sup> )	0.24 (1.31)			
Speed Regulation	Load	±0.5% (±0.2%)*2 max. (0~Rated torque, at rated speed, at rated voltage, at normal ambient temperature)			
	Voltage	±0.5% (±0.2%)*2 max. (Rated voltage -15~+10%, at rated speed, with no load, at normal ambient temperature)			
	Temperature	±0.5% (±0.2%)*2 max. [0~+50°C (+32~+122°F), at rated speed, with no load, at rated voltage]			
Gravitational Operation Ability	Continuous Regenerative Power	W (HP)	100 (1/8)		
	Instantaneous Regenerative Power	W (HP)	240 (1/3)		
	Applicable Regeneration Unit*3		<b>EPRC-400P</b>		
Electromagnetic Brake*4	Brake Type	Active when the power is off, automatically controlled by the driver			
	Static Friction Torque	N·m (oz-in)	0.2 (28)		

\*1 The starting torque can be used a maximum duration of approximately five seconds.

\*2 These specifications apply when a control module (sold separately) is used.

\*3 Install the regeneration unit in the place which has the same heat radiation capability as heat radiation plate [material: aluminum 350×350 mm (13.8×13.8 in.), 3 mm (0.12 in.) thick].

\*4 Do not start or stop the motor by turning on/off the power supply, as it will cause the electromagnetic brake to wear abnormally.

● The values for each specification apply to the motor only.

● Enter the gear ratio in the box (□) within the model name.

◇ 120 W (1/6 HP) (RoHS)



Model	Combination Type – Parallel Shaft Gearhead		BLE512CM□S-3, BLE512CM□S		BLE512SM□S-3, BLE512SM□S		
	Combination Type – Hollow Shaft Flat Gearhead		BLE512AM□F-3, BLE512AM□F		BLE512SM□F-3, BLE512SM□F		
Round Shaft Type		BLE512AMA-3, BLE512AMA		BLE512CMA-3, BLE512CMA		BLE512SMA-3, BLE512SMA	
Rated Output Power (Continuous)		W (HP)		120 (1/6)			
Power Source	Rated Voltage	VAC	Single-Phase 100-120	Single-Phase 200-240	Three-Phase 200-240		
	Permissible Voltage Range		-15~+10%				
	Rated Frequency	Hz	50/60				
	Permissible Frequency Range		±5%				
	Rated Input Current	A	3.3	2.0	1.2		
	Maximum Input Current	A	8.2	4.4	2.5		
Rated Torque		N·m (oz·in)	0.4 (56)				
Starting Torque*1		N·m (oz·in)	0.8 (113)				
Rated Speed		r/min	3000				
Speed Control Range		r/min	100~4000 (Analog setting), 80~4000 (Digital setting can be set in 1 r/min increments)*2				
Round Shaft Type							
Permissible Load Inertia J		×10 <sup>-4</sup> kg·m <sup>2</sup> (oz·in <sup>2</sup> )	5.6 (31)				
Rotor Inertia J		×10 <sup>-4</sup> kg·m <sup>2</sup> (oz·in <sup>2</sup> )	0.61 (3.3)				
Speed Regulation	Load	±0.5% (±0.2%)*2 max. (0~Rated torque, at rated speed, at rated voltage, at normal ambient temperature)					
	Voltage	±0.5% (±0.2%)*2 max. (Rated voltage -15~+10%, at rated speed, with no load, at normal ambient temperature)					
	Temperature	±0.5% (±0.2%)*2 max. [0~+50°C (+32~+122°F), at rated speed, with no load, at rated voltage]					
Gravitational Operation Ability	Continuous Regenerative Power	W (HP)	100 (1/8)				
	Instantaneous Regenerative Power	W (HP)	240 (1/3)				
	Applicable Regeneration Unit*3	<b>EPRC-400P</b>					
Electromagnetic Brake*4	Brake Type	Active when the power is off, automatically controlled by the driver					
	Static Friction Torque	N·m (oz·in)	0.4 (56)				

\*1 The starting torque can be used a maximum duration of approximately five seconds.

\*2 These specifications apply when a control module (sold separately) is used.

\*3 Install the regeneration unit in the place which has the same heat radiation capability as heat radiation plate [material: aluminum 350×350 mm (13.8×13.8 in.), 3 mm (0.12 in.) thick].

\*4 Do not start or stop the motor by turning on/off the power supply, as it will cause the electromagnetic brake to wear abnormally.

● The values for each specification apply to the motor only.

## Speed – Torque Characteristics

Continuous Duty Region: Continuous operation is possible in this region.

Limited Duty Region: This region is used primarily when accelerating. When a load that exceeds the rated torque is applied continuously for approximately five seconds, overload protection is activated and the motor coasts to a stop.

### ● 30 W (1/25 HP)

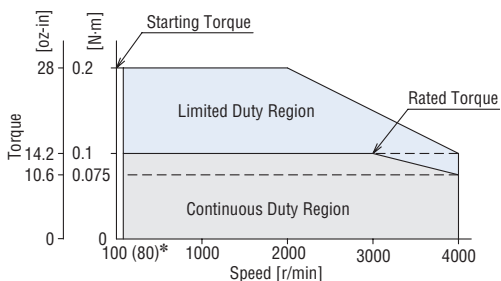

### ● 60 W (1/12 HP)

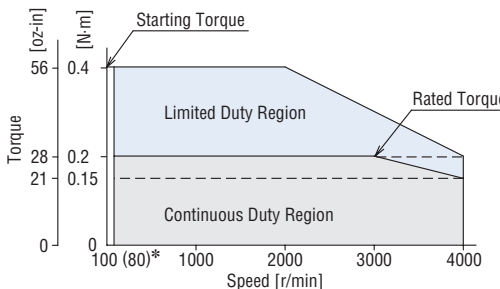

### ● 120 W (1/6 HP)

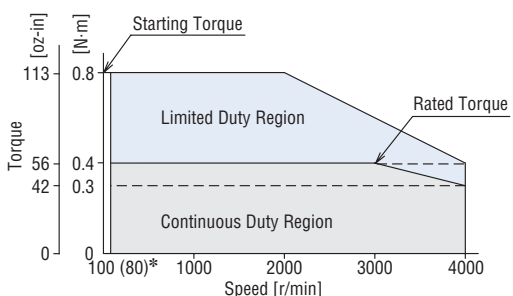

\* ( ) indicates: These specifications apply when a control module (sold separately) is used.

● The characteristics shown above apply to the motor only.



## Vertical Drive (Gravitational Operation)

The **BLE** Series provides stable speed control during gravitational operation.

During vertical drive shown in the figure to the right, normally an external force causes the motor to rotate and function as a power generator. If this energy is applied to the driver, an error will occur. The accessory regeneration unit (sold separately) can convert regenerative energy into thermal energy for dissipation. Use the accessory regeneration unit when using the motor for vertical applications or when braking a large inertial load quickly.

Regeneration resistor: **EPRC-400P**

Continuous regenerative power: 100 W (1/8 HP)

Instantaneous regenerative power: 240 W (1/3 HP)

- Attach to a location having the same radiation capability as the heat sink [material: aluminum 350×350 mm (13.8×13.8 in.), 3 mm (0.12 in.) thick].

### Note

- If using in a lift, the load may drop if it exceeds the rating or if the control module (sold separately) is used to set the torque limit to a small value. Depending on the load condition even if not exceeding the rated load, reversing may occur momentarily during startup or shutdown.

### Regenerative Power

The regenerative power can be estimated using the formula below. Use the calculated value as a guideline.

$$\text{Regenerative Power (W)} = 0.1047 \times T_L \text{ [N}\cdot\text{m]} \times N \text{ [r/min]}$$

$T_L$ : Load torque  $N$ : Speed

- Use the electromagnetic brake type for gravitational operation.

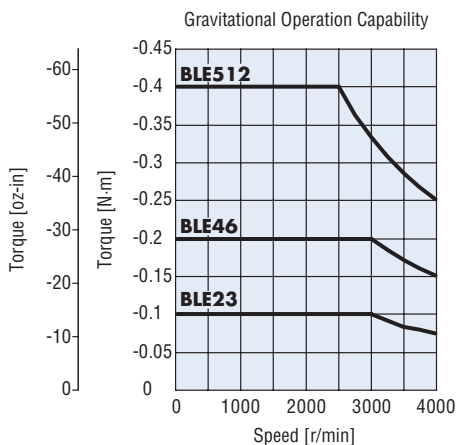
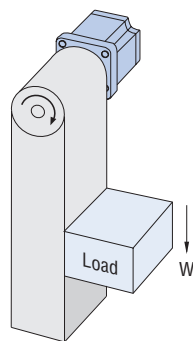

- Gravitational operation exceeding the range of continuous regeneration capability will trigger the built-in thermal protector [150°C (302°F)].

## General Specifications

Item	Motor	Driver
Insulation Resistance	100 MΩ or more when 500 VDC megger is applied between the windings and the case after continuous operation under normal ambient temperature and humidity.	The measured value is 100 MΩ or more when a 500 VDC megger is applied between the power supply terminal and the protective earth terminal and between the power supply terminal and the I/O signal terminal after continuous operation under normal ambient temperature and humidity.
Dielectric Strength	Sufficient to withstand 1.5 kVAC at 50 Hz applied between the windings and the case for 1 minute after continuous operation under normal ambient temperature and humidity.	No abnormality is judged even with application of 1834 VAC at 50 Hz between the power supply terminal and the protective earth terminal and with application of 3 kVAC at 50 Hz between the power supply terminal and the I/O terminal for 1 minute after continuous operation under normal ambient temperature and humidity.
Temperature Rise	Temperature rise of the windings and the case are 50°C (90°F) or less, and 40°C (72°F) or less*1 respectively measured by the thermocouple method after continuous operation under normal ambient temperature and humidity.	Temperature rise of the heat radiation plate is 50°C (90°F) or less measured by the thermocouple method after continuous operation under normal ambient temperature and humidity.
Operating Environment	Ambient Temperature	0~+50°C (+32~+122°F)
	Ambient Humidity	85% or less (non-condensing)
	Altitude	Up to 1000 m (3300 ft.) above sea level
	Atmosphere	No corrosive gases or dust. Cannot be used in a radioactive area, magnetic field, vacuum or other special environment
	Vibration	Not subject to continuous vibration or excessive impact In conformance with JIS C 60068-2-6, "Sine-wave vibration test method" Frequency range: 10~55 Hz Pulsating amplitude: 0.15 mm (0.006 in.) Sweep direction: 3 directions (X, Y, Z) Number of sweeps: 20 times
Storage Condition*2	Ambient Temperature	-25~+70°C (-13~+158°F) (non-freezing)
	Ambient Humidity	85% or less (non-condensing)
	Altitude	Up to 3000 m (10000 ft.) above sea level
Thermal Class	UL/CSA standards: 105 (A), EN standards: 120 (E)	—
Degree of Protection	IP65 (Excluding the mounting surface of the round shaft type and connectors)	IP20

\*1 For round shaft types, please attach to the heat radiation plate (material: aluminum) of the following sizes to maintain a maximum motor case temperature of 90°C (194°F).

- 30 W (1/25 HP) Standard Type: 115×115 mm (4.53×4.53 in.), 5 mm (0.20 in.) thick
- 30 W (1/25 HP) With Electromagnetic Brake Type: 135×135 mm (5.31×5.31 in.), 5 mm (0.20 in.) thick
- 60 W (1/12 HP) Type: 135×135 mm (5.31×5.31 in.), 5 mm (0.20 in.) thick
- 120 W (1/6 HP) Type: 165×165 mm (6.50×6.50 in.), 5 mm (0.20 in.) thick

\*2 The storage condition applies to a short period such as a period during transportation.

### Note

- Do not measure insulation resistance or perform the dielectric strength test while the motor and driver are connected.

## Common Specifications

- Standard Model: These specifications apply when the basic motor/driver package is used.
- Extended Functions: These specifications apply when a control module (sold separately) is used.

Item	Standard Model	Extended Functions
Speed Setting Methods	Select one of the following methods. ·Set using the internal speed potentiometer ·Set using an external speed potentiometer (included): <b>PAVR-20KZ</b> (20 kΩ, 1/4 W) ·Set using external DC voltage: 0~5 VDC or 0~10 VDC, 1 mA min.	Select one of the following methods. ·Digital Setting ( <b>OPX-2A</b> or <b>MEXE02</b> ) ·Set using the internal speed potentiometer ·Set using an external speed potentiometer (included): <b>PAVR-20KZ</b> (20 kΩ, 1/4 W) ·Set using external DC voltage: 0~5 VDC or 0~10 VDC, 1 mA min.
Acceleration and Deceleration Time	Set using acceleration and deceleration time potentiometer: 0.2~15 seconds (3000 r/min at no load)	Select one of the following methods: ·Digital Setting ( <b>OPX-2A</b> or <b>MEXE02</b> ): 0.2~15 seconds (time until setting speed is achieved) ·Set using acceleration and deceleration time potentiometer: 0.2~15 seconds (3000 r/min with no load)
Multi-Speed Setting Methods	2 Speeds: 1 speed set by the internal speed potentiometer and 1 speed set by the external speed potentiometer (20 kΩ, 1/4 W) or external DC voltage (0~5 VDC or 0~10 VDC)	Select one of the following methods: ·8 Speeds: 8 speeds set by digital setting ( <b>OPX-2A</b> or <b>MEXE02</b> ) ·8 Speeds: 6 speeds set by digital setting ( <b>OPX-2A</b> or <b>MEXE02</b> ) and 2 speeds set by analog setting*1
Input Signals	Photocoupler Input Input Resistance 5.1 kΩ Operated by Internal Power Supply: 17 VDC±10% Connectable External DC Power Supply: 24 VDC -15~+20% Current 100 mA min.	
	Forward input (FWD), Reverse input (REV), Stop mode selection input, Speed setting selection input (MO), Alarm reset input, Electromagnetic brake release input (MB-FREE), Regeneration unit thermal input (TH)	Arbitrary signal assignment to general purpose input X0~X6 (7 points) is possible Forward input (FWD), Reverse input (REV), Stop mode selection input, Speed setting selection input (MO, M1, M2), Alarm reset input, Electromagnetic brake release input (MB-FREE), Regeneration unit thermal input (TH), External error input (EXT-ERROR)
Output Signals	Open-collector output External Use Condition: Voltage control 4.5~30.0 VDC Current 40 mA max. Speed Output: 5 mA min.	
	Speed output, Alarm output 1	Arbitrary signal assignment to general purpose output Y0, Y1 (2 points) is possible Speed output, Alarm output 1, Motor running output (MOVE), Speed attainment output (VA), Alarm output 2, Warning output (WNG), Torque limit output (TLC)
Protective Functions	When the following protective functions are activated, the motor will coast to a stop and the ALARM output will be OFF. The alarm LED on the driver will blink for the corresponding number of times shown in (.) ·Overload Protective Function (2): Activated when the motor load has exceeded rated torque for approximately 5 seconds min. ·Sensor Error (3): Activated when an abnormality occurs with the signal from the motor such as when the sensor signal line of the motor disconnects during operation or when the connector for the signal comes off. ·Initial Sensor Error (3): Activated when an abnormality occurs with the signal from the motor before the main power supply was turned on such as when the sensor signal line of the motor disconnects during operation or when the connector for the signal comes off. ·Overvoltage Protective Function (4): Activated when the main power supply voltage applied exceeds the rated voltage by approximately 20%, a gravitational operation was performed or a load exceeding the permissible load inertia was driven. ·Undervoltage Protective Function (5): Activated when the main power supply voltage drops below the rated voltage by 40% or less. ·Overspeed Protective Function (6): Activated when the motor speed exceeds approximately 4800 r/min. ·Overcurrent Protective Function (7): Activated when an excessive current flowed through the driver due to ground fault, etc. ·EEPROM Error (8): Activated when data can not be written or read due to damage to saved data. ·Regeneration Unit Overheat Protective Function (9): Activated when regeneration unit overheat is detected or when the thermal protector output lead wire is disconnected during operation. ·External Stop*2 (10): Activated when external error input (EXT-ERROR) is turned OFF. ·Initial Operation Inhibition*3 (11): Activated when FWD input or REV input turns ON or when the main power supply is turned on again (initial value invalid). ·Main Circuit Output Error*4 (14): Activated when operation signal is input while the motor power line is disconnected or the power connector has come off.	
Maximum Extension Distance	Motor and Driver Distance 20.4 m (66.9 ft.)	
Time Rating	Continuous	

\*1 One speed set by the internal speed potentiometer and one speed set by the external speed potentiometer (20 kΩ, 1/4 W) or external DC voltage (0~5 VDC or 0~10 VDC).

\*2 Limited to when the control module (sold separately) is used for assigning the external error input (EXT-ERROR).

\*3 Activates only when the control module (sold separately) is used and the function has been set to be available. Invalid when the **FBL II** compatibility mode is set.

\*4 Does not activate when the control module (sold separately) is used to set the torque limiting value to less than 200%.

## Torque Limiting Function Specifications

A limit can be set on the output torque of the motor by using a control module (sold separately).

Item	Specifications
Torque Limiting Setting Methods	Select one of the following methods · Digital Independent Setting: A torque limiting value can be set independently for each data set of 8 data. · External Analog Common Setting: A torque limiting value can be set for all data sets in one operation via external speed potentiometer <b>PAVR-20KZ</b> (20 kΩ, 1/4 W) or with external DC voltage (0~5 VDC or 0~10 VDC). This torque limiting value applies to all operation data.
Torque Limiting Setting Range	Assuming that the rated torque of the motor is 100%, torque limiting values can be set by one of the following settings. (Initial value 200%) · Digital Setting: 0~200% (can be set in 1% units) · External Analog Common Setting: Set from 0~200% with an external speed potentiometer <b>PAVR-20KZ</b> (20 kΩ, 1/4 W) or with external DC voltage (0~5 VDC or 0~10 VDC)

### Note

- An error up to a maximum of approximately ±20% (during rated torque and rated speed) may occur between the setting value and generated torque due to the setting speed, power supply voltage and motor cable extension length.

## ■ Gearmotor – Torque Table of Combination Type

### ● Combination Type – Parallel Shaft Gearhead

Unit = N-m (lb-in)

Model	Gear Ratio	5	10	15	20	30	50	100	200
	100 r/min	20	10	6.7	5	3.3	2	1	0.5
	3000 r/min	600	300	200	150	100	60	30	15
	4000 r/min	800	400	267	200	133	80	40	20
<b>BLE23</b> <input type="checkbox"/> <b>S-3</b>	100~3000 r/min	0.45 (3.9)	0.90 (7.9)	1.4 (12.3)	1.8 (15.9)	2.6 (23)	4.3 (38)	6 (53)	6 (53)
<b>BLE23</b> <input type="checkbox"/> <b>S</b>	4000 r/min	0.34 (3.0)	0.68 (6.0)	1.0 (8.8)	1.4 (12.3)	1.9 (16.8)	3.2 (28)	5.4 (47)	5.4 (47)
<b>BLE46</b> <input type="checkbox"/> <b>S-3</b>	100~3000 r/min	0.90 (7.9)	1.8 (15.9)	2.7 (23)	3.6 (31)	5.2 (46)	8.6 (76)	16 (141)	16 (141)
<b>BLE46</b> <input type="checkbox"/> <b>S</b>	4000 r/min	0.68 (6.0)	1.4 (12.3)	2.0 (17.7)	2.7 (23)	3.9 (34)	6.5 (57)	12.9 (114)	14 (123)
<b>BLE512</b> <input type="checkbox"/> <b>S-3</b>	100~3000 r/min	1.8 (15.9)	3.6 (31)	5.4 (47)	7.2 (63)	10.3 (91)	17.2 (152)	30 (260)	30 (260)
<b>BLE512</b> <input type="checkbox"/> <b>S</b>	4000 r/min	1.4 (12.3)	2.7 (23)	4.1 (36)	5.4 (47)	7.7 (68)	12.9 (114)	25.8 (220)	27 (230)

● A colored background (  ) indicates gear shaft rotation in the same direction as the motor shaft, while the others rotate in the opposite direction.

### ● Combination Type – Hollow Shaft Gearhead

Unit = N-m (lb-in)

Model	Gear Ratio	5	10	15	20	30	50	100	200
	100 r/min	20	10	6.7	5	3.3	2	1	0.5
	3000 r/min	600	300	200	150	100	60	30	15
	4000 r/min	800	400	267	200	133	80	40	20
<b>BLE23</b> <input type="checkbox"/> <b>F-3</b>	100~3000 r/min	0.4 (3.5)	0.85 (7.5)	1.3 (11.5)	1.7 (15.0)	2.6 (23)	4.3 (38)	8.5 (75)	17 (150)
<b>BLE23</b> <input type="checkbox"/> <b>F</b>	4000 r/min	0.3 (2.6)	0.64 (5.6)	0.96 (8.4)	1.3 (11.5)	1.9 (16.8)	3.2 (28)	6.4 (56)	12.8 (113)
<b>BLE46</b> <input type="checkbox"/> <b>F-3</b>	100~3000 r/min	0.85 (7.5)	1.7 (15.0)	2.6 (23)	3.4 (30)	5.1 (45)	8.5 (75)	17 (150)	34 (300)
<b>BLE46</b> <input type="checkbox"/> <b>F</b>	4000 r/min	0.64 (5.6)	1.3 (11.5)	1.9 (16.8)	2.6 (23)	3.8 (33)	6.4 (56)	12.8 (113)	25.5 (220)
<b>BLE512</b> <input type="checkbox"/> <b>F-3</b>	100~3000 r/min	1.7 (15.0)	3.4 (30)	5.1 (45)	6.8 (60)	10.2 (90)	17 (150)	34 (300)	68 (600)
<b>BLE512</b> <input type="checkbox"/> <b>F</b>	4000 r/min	1.3 (11.5)	2.6 (23)	3.8 (33)	5.1 (45)	7.7 (68)	12.8 (113)	25.5 (220)	51 (450)

● The flat gearhead rotates in the opposite direction to the motor when viewed from the front face of the gearhead. It rotates in the same direction as the motor when viewed from the rear (motor mounting surface) of the gearhead. Rotation direction of hollow shaft flat gearhead → Page D-243

## ■ Permissible Overhung Load and Permissible Thrust Load

### ● Combination Type – Parallel Shaft Gearhead

Model	Gear Ratio		Permissible Overhung Load				Permissible Thrust Load	
			10 mm (0.39 in.) from shaft end		20 mm (0.79 in.) from shaft end			
			N	lb.	N	lb.	N	lb.
<b>BLE23</b> <input type="checkbox"/> <b>S-3</b> <b>BLE23</b> <input type="checkbox"/> <b>S</b>	5	100~3000 r/min	100	22	150	33	40	9
		4000 r/min	90	20	110	24		
	10, 15, 20	100~3000 r/min	150	33	200	45		
		4000 r/min	130	29	170	38		
	30, 50, 100, 200	100~3000 r/min	200	45	300	67		
		4000 r/min	180	40	230	51		
<b>BLE46</b> <input type="checkbox"/> <b>S-3</b> <b>BLE46</b> <input type="checkbox"/> <b>S</b>	5	100~3000 r/min	200	45	250	56	100	22
		4000 r/min	180	40	220	49		
	10, 15, 20	100~3000 r/min	300	67	350	78		
		4000 r/min	270	60	330	74		
	30, 50, 100, 200	100~3000 r/min	450	101	550	123		
		4000 r/min	420	94	500	112		
<b>BLE512</b> <input type="checkbox"/> <b>S-3</b> <b>BLE512</b> <input type="checkbox"/> <b>S</b>	5	100~3000 r/min	300	67	400	90	150	33
		4000 r/min	230	51	300	67		
	10, 15, 20	100~3000 r/min	400	90	500	112		
		4000 r/min	370	83	430	96		
	30, 50, 100, 200	100~3000 r/min	500	112	650	146		
		4000 r/min	450	101	550	123		

● Enter the power supply voltage **A**, **C** or **S** (**AM**, **CM**, or **SM**: Electromagnetic brake type) in the box (  ) within the model name.  
Enter the gear ratio in the box (  ) within the model name.

## ● Combination Type – Hollow Shaft Flat Gearhead

Model	Gear Ratio		Permissible Overhung Load				Permissible Thrust Load	
			10 mm (0.39 in.) from mounting surface of gearhead		20 mm (0.79 in.) from mounting surface of gearhead			
			N	lb.	N	lb.	N	lb.
<b>BLE23</b> □□ <b>F-3</b> <b>BLE23</b> □□ <b>F</b>	<b>5, 10</b>	100~3000 r/min	450	101	370	83	200	45
		4000 r/min	410	92	330	74		
	<b>15, 20, 30, 50, 100, 200</b>	100~3000 r/min	500	112	400	90		
		4000 r/min	460	103	370	83		
<b>BLE46</b> □□ <b>F-3</b> <b>BLE46</b> □□ <b>F</b>	<b>5, 10</b>	100~3000 r/min	800	180	660	148	400	90
		4000 r/min	730	164	600	135		
	<b>15, 20, 30, 50, 100, 200</b>	100~3000 r/min	1200	270	1000	220		
		4000 r/min	1100	240	910	200		
<b>BLE512</b> □□ <b>F-3</b> <b>BLE512</b> □□ <b>F</b>	<b>5, 10</b>	100~3000 r/min	900	200	770	173	500	112
		4000 r/min	820	184	700	157		
	<b>15, 20</b>	100~3000 r/min	1300	290	1110	240		
		4000 r/min	1200	270	1020	220		
	<b>30, 50, 100, 200</b>	100~3000 r/min	1500	330	1280	280		
		4000 r/min	1400	310	1200	270		

● The permissible overhung load can also be calculated with a formula. Permissible overhung load calculation → Page D-242

## ● Round Shaft Type

Model	Permissible Overhung Load				Permissible Thrust Load
	10 mm (0.39 in.) from shaft end		20 mm (0.79 in.) from shaft end		
	N	lb.	N	lb.	
<b>BLE23</b> □□ <b>A-3</b> <b>BLE23</b> □□ <b>A</b>	80	18	100	22	The permissible thrust load should not be greater than half the motor mass.
<b>BLE46</b> □□ <b>A-3</b> <b>BLE46</b> □□ <b>A</b>	110	24	130	29	
<b>BLE512</b> □□ <b>A-3</b> <b>BLE512</b> □□ <b>A</b>	150	33	170	38	

## ■ Permissible Load Inertia: J of Combination Type

### ● Combination Type – Parallel Shaft Gearhead

Unit =  $\times 10^{-4}$ kg·m<sup>2</sup> (oz·in<sup>2</sup>)

Model	Gear Ratio	5	10	15	20	30	50	100	200
		<b>BLE23</b> □□ <b>S-3</b> <b>BLE23</b> □□ <b>S</b>	12 (66)	50 (270)	110 (600)	200 (1090)	370 (2000)	920 (5000)	2500 (13700)
<b>BLE46</b> □□ <b>S-3</b> <b>BLE46</b> □□ <b>S</b>	When instantaneous stop or instantaneous bi-directional operation is performed	1.55 (8.5)	6.2 (34)	14.0 (77)	24.8 (136)	55.8 (310)	155 (850)	155 (850)	155 (850)
	22 (120)	95 (520)	220 (1200)	350 (1910)	800 (4400)	2200 (12000)	6200 (34000)	12000 (66000)	
<b>BLE512</b> □□ <b>S-3</b> <b>BLE512</b> □□ <b>S</b>	When instantaneous stop or instantaneous bi-directional operation is performed	5.5 (30)	22 (120)	49.5 (270)	88 (480)	198 (1080)	550 (3000)	550 (3000)	550 (3000)
	45 (250)	190 (1040)	420 (2300)	700 (3800)	1600 (8800)	4500 (25000)	12000 (66000)	25000 (137000)	
<b>BLE512</b> □□ <b>S-3</b> <b>BLE512</b> □□ <b>S</b>	When instantaneous stop or instantaneous bi-directional operation is performed	25 (137)	100 (550)	225 (1230)	400 (2200)	900 (4900)	2500 (13700)	2500 (13700)	2500 (13700)
	25 (137)	100 (550)	225 (1230)	400 (2200)	900 (4900)	2500 (13700)	2500 (13700)	2500 (13700)	

### ● Combination Type – Hollow Shaft Gearhead

Unit =  $\times 10^{-4}$ kg·m<sup>2</sup> (oz·in<sup>2</sup>)

Model	Gear Ratio	5	10	15	20	30	50	100	200
		<b>BLE23</b> □□ <b>F-3</b> <b>BLE23</b> □□ <b>F</b>	12 (66)	50 (270)	110 (600)	200 (1090)	370 (2000)	920 (5000)	2500 (13700)
<b>BLE46</b> □□ <b>F-3</b> <b>BLE46</b> □□ <b>F</b>	When instantaneous stop or instantaneous bi-directional operation is performed	1.55 (8.5)	6.2 (34)	14.0 (77)	24.8 (136)	55.8 (310)	155 (850)	155 (850)	155 (850)
	22 (120)	95 (520)	220 (1200)	350 (1910)	800 (4400)	2200 (12000)	6200 (34000)	12000 (66000)	
<b>BLE512</b> □□ <b>F-3</b> <b>BLE512</b> □□ <b>F</b>	When instantaneous stop or instantaneous bi-directional operation is performed	5.5 (30)	22 (120)	49.5 (270)	88 (480)	198 (1080)	550 (3000)	550 (3000)	550 (3000)
	45 (250)	190 (1040)	420 (2300)	700 (3800)	1600 (8800)	4500 (25000)	12000 (66000)	25000 (137000)	
<b>BLE512</b> □□ <b>F-3</b> <b>BLE512</b> □□ <b>F</b>	When instantaneous stop or instantaneous bi-directional operation is performed	25 (137)	100 (550)	225 (1230)	400 (2200)	900 (4900)	2500 (13700)	2500 (13700)	2500 (13700)
	25 (137)	100 (550)	225 (1230)	400 (2200)	900 (4900)	2500 (13700)	2500 (13700)	2500 (13700)	

● Enter the power supply voltage **A**, **C** or **S** (**AM**, **CM**, or **SM**: Electromagnetic brake type) in the box (□) within the model name.  
Enter the gear ratio in the box (□) within the model name.

## Dimensions Unit = mm (in.)

● Mounting screws are included with the combination type. Dimensions for mounting screws → Page D-242

● Standard Type 30 W (1/25 HP)

◇ Motor/Parallel Shaft Gearhead

Model	Motor Model	Gearhead Model	Gear Ratio	L	Mass kg (lb.)	DXF
<b>BLE23A□S-3, BLE23A□S</b> <b>BLE23C□S-3, BLE23C□S</b> <b>BLE23S□S-3, BLE23S□S</b>	BLEM23-GFS	GFS2G□	<b>5~20</b>	34 (1.34)	1.1 (2.4)	A694A
<b>30~100</b>			38 (1.50)	A694B		
<b>200</b>			43 (1.69)	A694C		

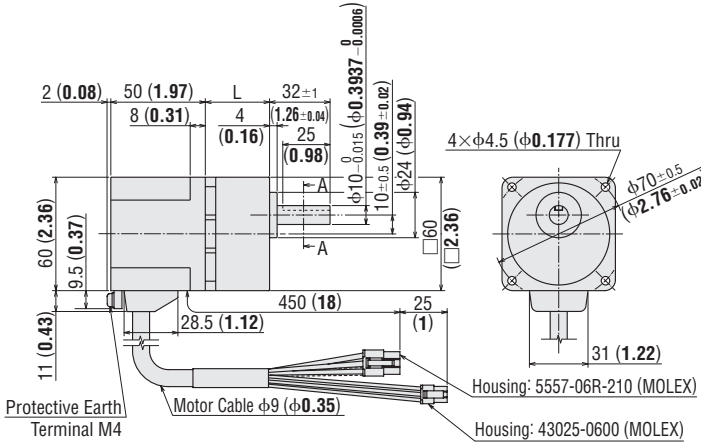

### ◇ Key and Key Slot (Included)

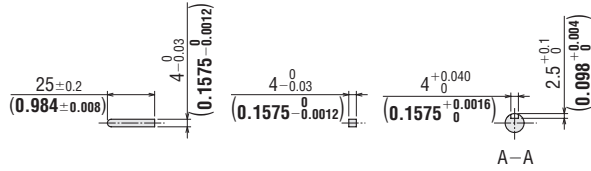

### ◇ Motor/Hollow Shaft Flat Gearhead

**BLE23A□F-3, BLE23A□F, BLE23C□F-3, BLE23C□F, BLE23S□F-3, BLE23S□F**

Motor: BLEM23-GFS

Gearhead: GFS2G□FR

Mass: 1.4 kg (3.1 lb.) (Including gearhead)

DXF A695

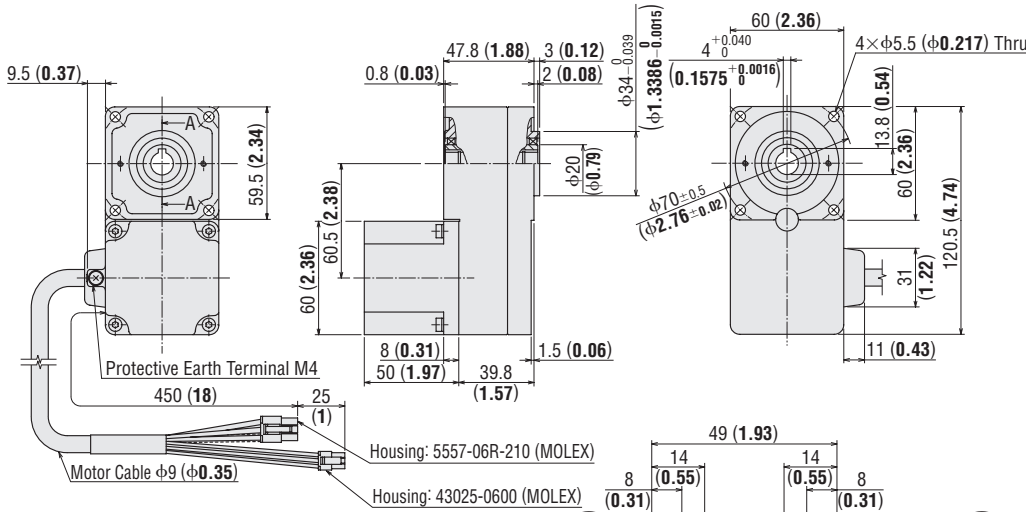

### ◇ Key (Included)

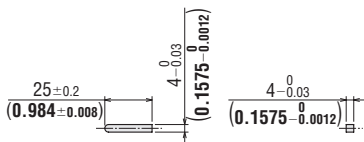

● Enter the gear ratio in the box (□) within the model name.

## ◇ Round Shaft Type

**BLE23AA-3, BLE23AA, BLE23CA-3, BLE23CA, BLE23SA-3, BLE23SA**

Motor: BLEM23-A

Mass: 0.6 kg (1.32 lb.)

**DXF** A696

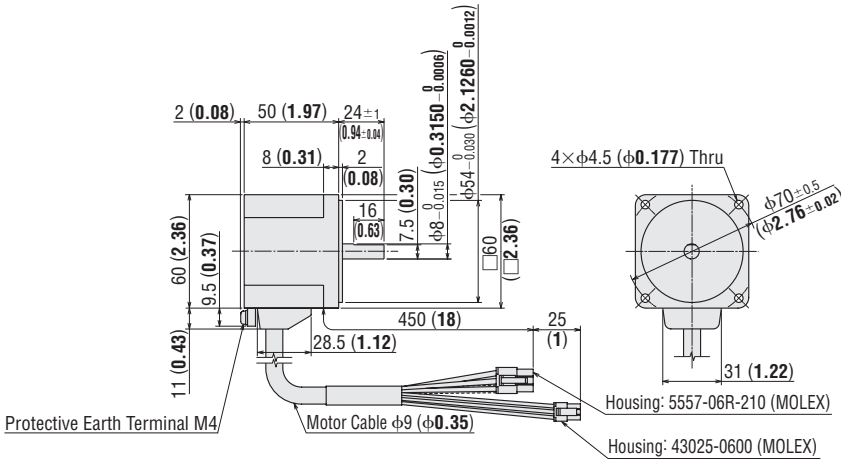

## ● Standard Type 60 W (1/12 HP)

### ◇ Motor/Parallel Shaft Gearhead

Model	Motor Model	Gearhead Model	Gear Ratio	L	Mass kg (lb.)	DXF
<b>BLE46A□S-3, BLE46A□S</b>	BLEM46-GFS	GFS4G□	<b>5~20</b>	41 (1.61)	1.9 (4.2)	A697A
<b>BLE46C□S-3, BLE46C□S</b>			<b>30~100</b>	46 (1.81)		A697B
<b>BLE46S□S-3, BLE46S□S</b>			<b>200</b>	51 (2.01)		A697C

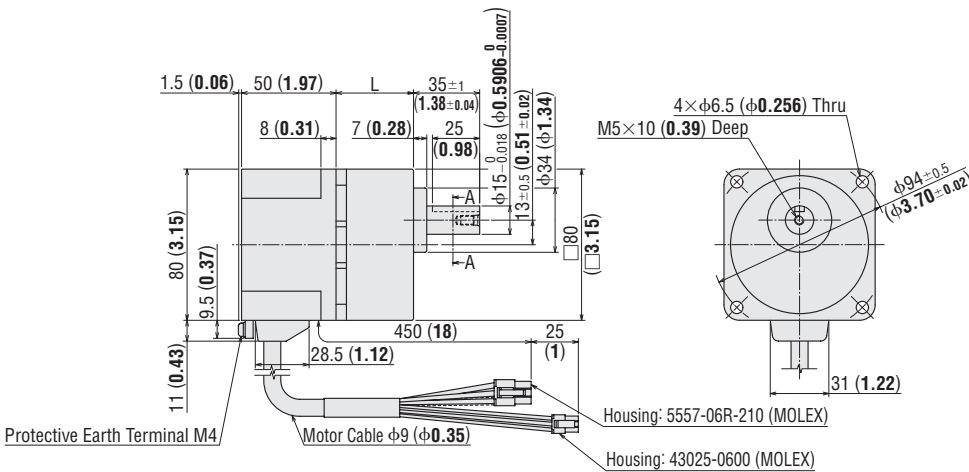

## ◇ Key and Key Slot (Included)

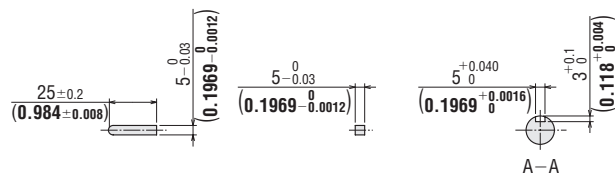

● Enter the gear ratio in the box (□) within the model name.

## ◇ Motor/Hollow Shaft Flat Gearhead

**BLE46A□F-3, BLE46A□F, BLE46C□F-3, BLE46C□F, BLE46S□F-3, BLE46S□F**

Motor: BLEM46-GFS

Gearhead: GFS4G□FR

Mass: 2.5 kg (5.5 lb.) (Including gearhead)

**DXF** A698

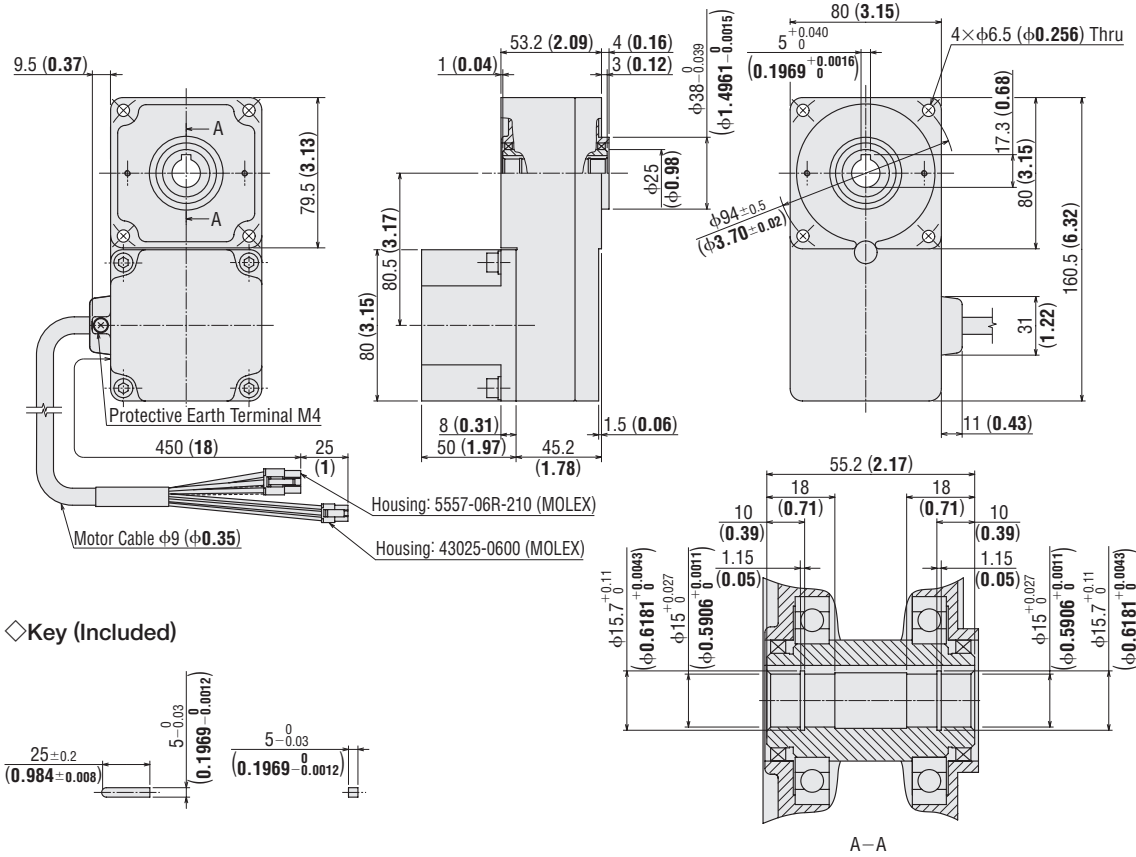

## ◇ Key (Included)

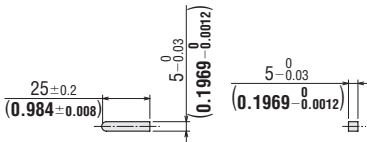

## ◇ Round Shaft Type

**BLE46AA-3, BLE46AA, BLE46CA-3, BLE46CA, BLE46SA-3, BLE46SA**

Motor: BLEM46-A

Mass: 0.9 kg (2.0 lb.)

**DXF** A699

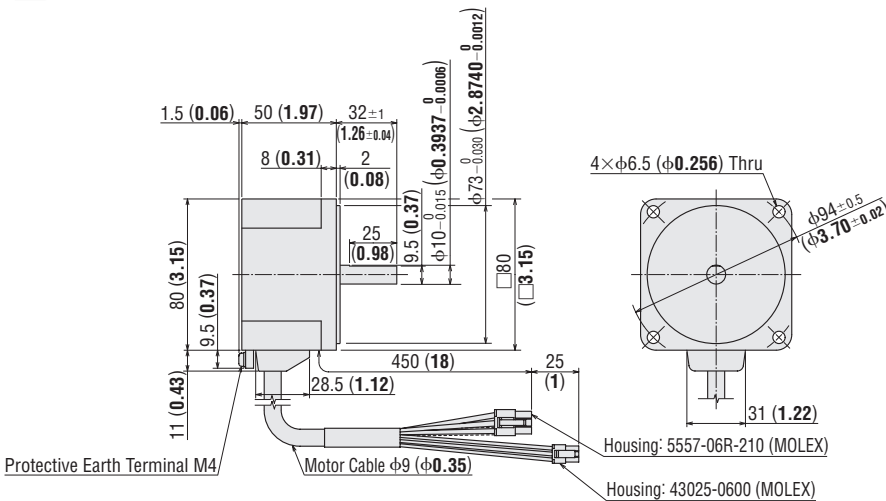

● Enter the gear ratio in the box (□) within the model name.

● Standard Type 120 W (1/6 HP)

◇ Motor/Parallel Shaft Gearhead

Model	Motor Model	Gearhead Model	Gear Ratio	L	Mass kg (lb.)	DXF
<b>BLE512A□S-3, BLE512A□S</b>	BLEM512-GFS	GFS5G□	<b>5~20</b>	45 (1.77)	3.0 (6.6)	A700A
<b>BLE512C□S-3, BLE512C□S</b>			<b>30~100</b>	58 (2.28)		A700B
<b>BLE512S□S-3, BLE512S□S</b>			<b>200</b>	64 (2.52)		A700C

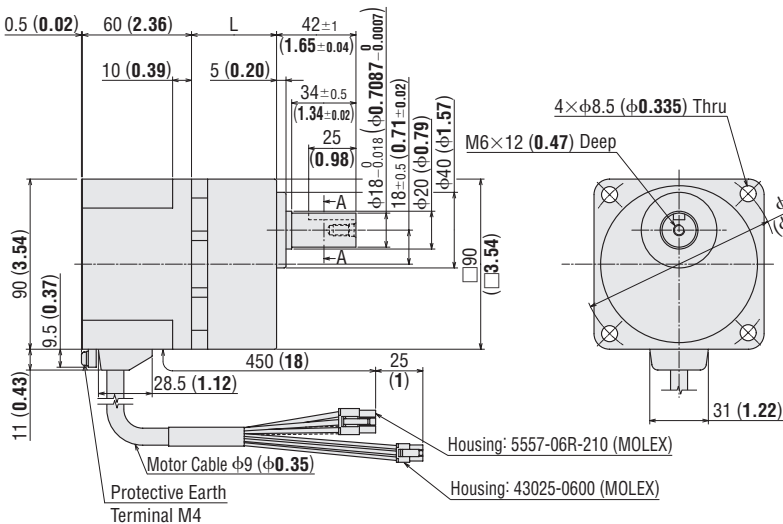

◇ Key and Key Slot (Included)

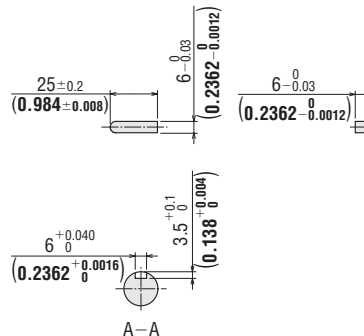

◇ Motor/Hollow Shaft Flat Gearhead

**BLE512A□F-3, BLE512A□F, BLE512C□F-3, BLE512C□F, BLE512S□F-3, BLE512S□F**

Motor: BLEM512-GFS

Gearhead: GFS5G□FR

Mass: 3.7 kg (8.1 lb.) (Including gearhead)

**DXF** A701

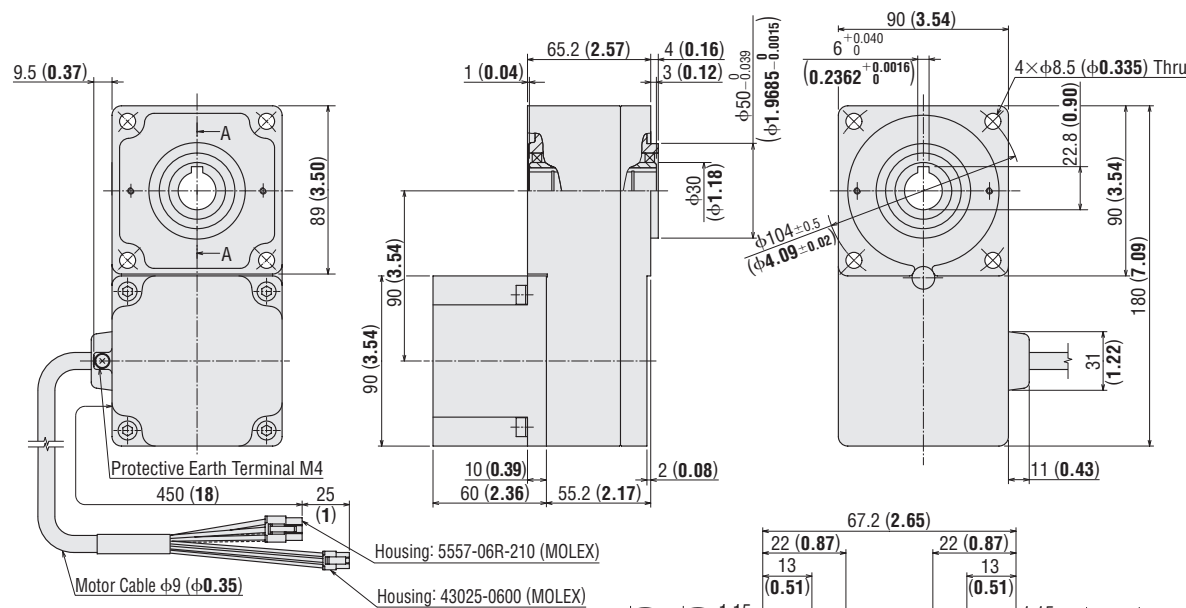

◇ Key (Included)

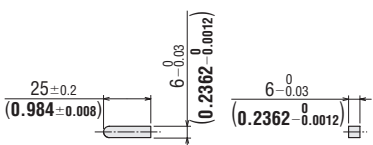

● Enter the gear ratio in the box (□) within the model name.



## ◇ Round Shaft Type

**BLE512AA-3, BLE512AA, BLE512CA-3, BLE512CA, BLE512SA-3, BLE512SA**

Motor: BLEM512-A

Mass: 1.5 kg (3.3 lb.)

**DXF** A702

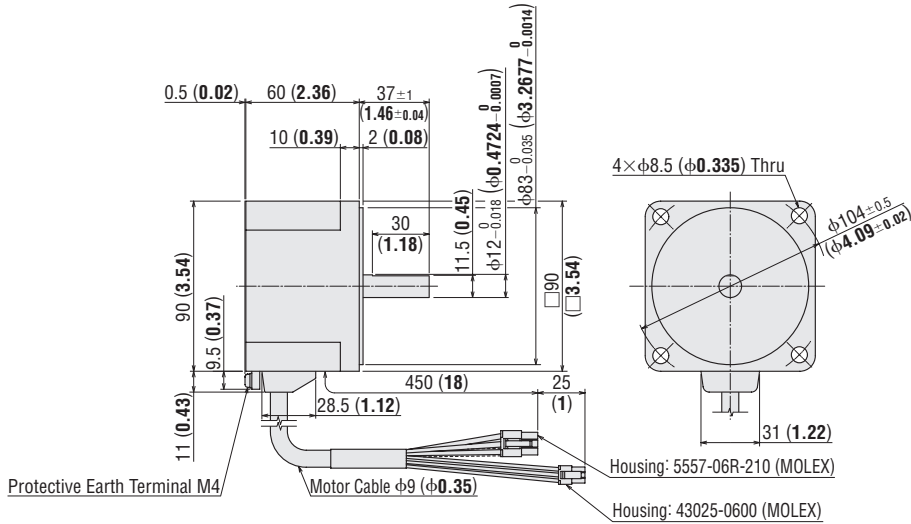

## ● With Electromagnetic Brake Type 30 W (1/25 HP)

### ◇ Motor/Parallel Shaft Gearhead

Model	Motor Model	Gearhead Model	Gear Ratio	L	Mass kg (lb.)	DXF
<b>BLE23AM□S-3, BLE23AM□S</b>	BLEM23M2-GFS	GFS2G□	<b>5-20</b>	34 (1.34)	1.4 (3.1)	A1132A
<b>BLE23CM□S-3, BLE23CM□S</b>			<b>30-100</b>	38 (1.50)		A1132B
<b>BLE23SM□S-3, BLE23SM□S</b>			<b>200</b>	43 (1.69)		A1132C

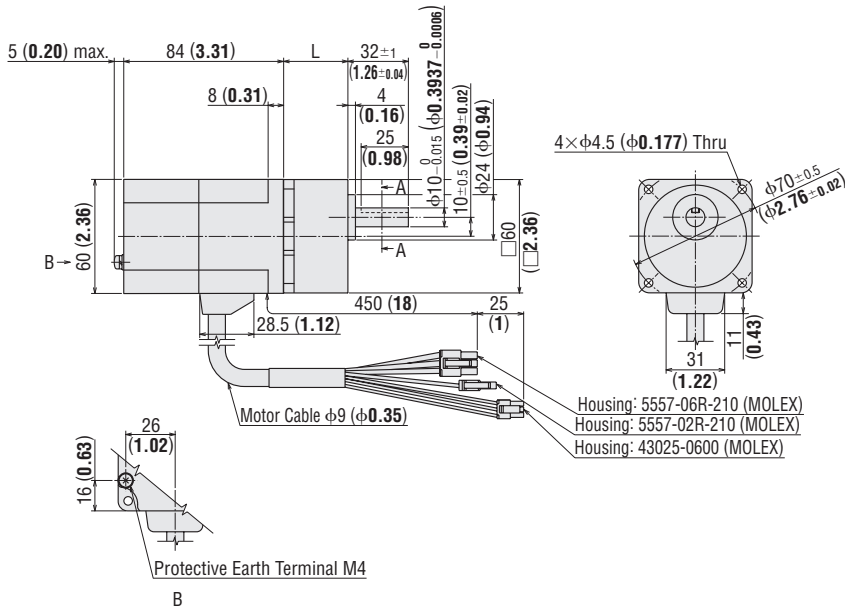

### ◇ Key and Key Slot (Included)

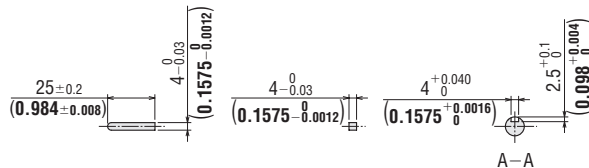

● Enter the gear ratio in the box (□) within the model name.

## ◇ Motor/Hollow Shaft Flat Gearhead

**BLE23AM□F-3, BLE23AM□F, BLE23CM□F-3, BLE23CM□F, BLE23SM□F-3, BLE23SM□F**

Motor: BLEM23M2-GFS

Gearhead: GFS2G□FR

Mass: 1.7 kg (3.7 lb.) (Including gearhead)

**DXF** A1133

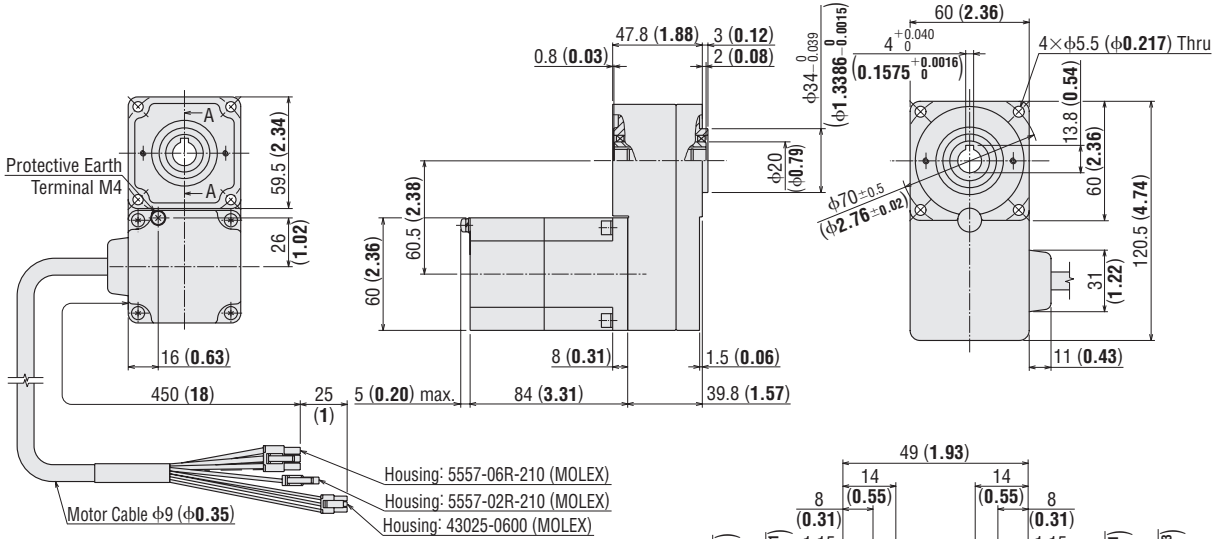

## ◇ Key (Included)

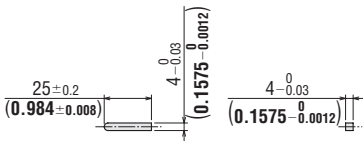

## ◇ Round Shaft Type

**BLE23AMA-3, BLE23AMA, BLE23CMA-3, BLE23CMA, BLE23SMA-3, BLE23SMA**

Motor: BLEM23M2-A

Mass: 0.9 kg (2.0 lb.)

**DXF** A1134

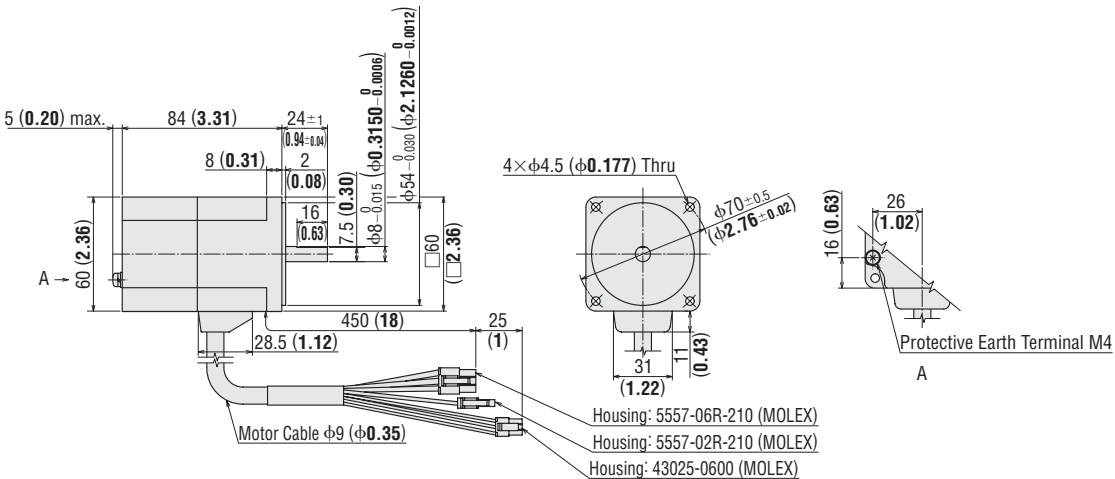

● Enter the gear ratio in the box (□) within the model name.

## ● With Electromagnetic Brake Type 60 W (1/12 HP)

### ◇ Motor/Parallel Shaft Gearhead

Model	Motor Model	Gearhead Model	Gear Ratio	L	Mass kg (lb.)	DXF
<b>BLE46AM□S-3, BLE46AM□S</b> <b>BLE46CM□S-3, BLE46CM□S</b> <b>BLE46SM□S-3, BLE46SM□S</b>	BLEM46M2-GFS	GFS4G□	<b>5~20</b>	41 (1.61)	2.5 (5.5)	A1135A
<b>30~100</b>			46 (1.81)	A1135B		
<b>200</b>			51 (2.01)	A1135C		

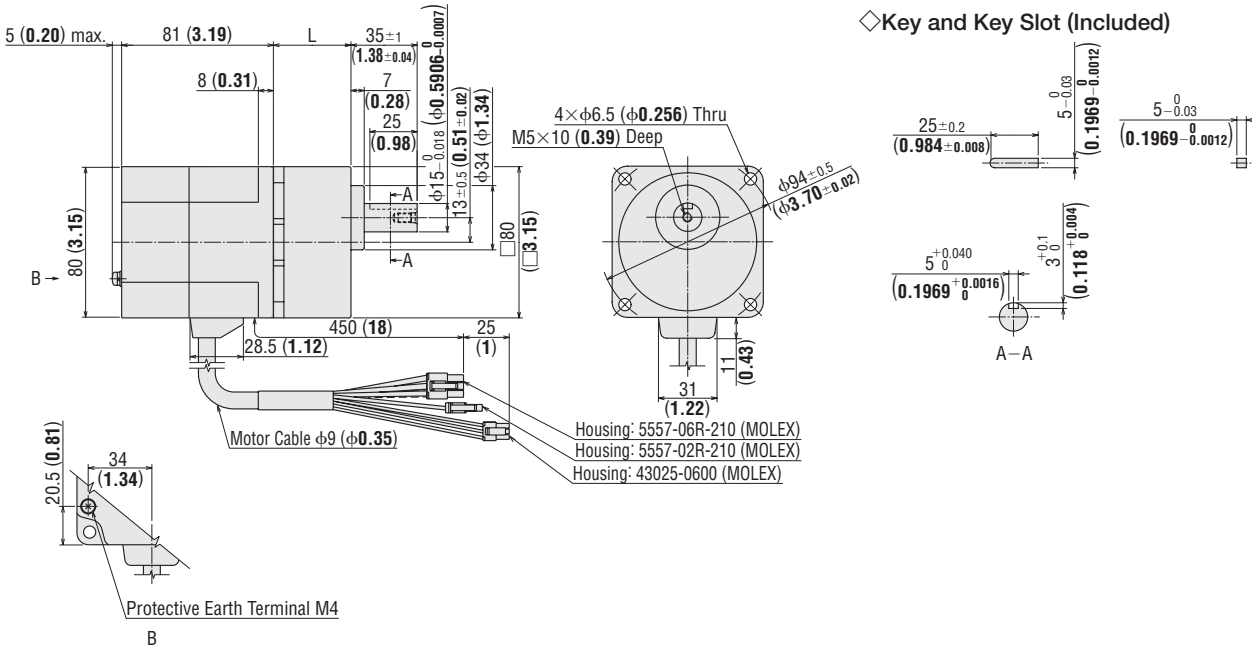

### ◇ Key and Key Slot (Included)

### ◇ Motor/Hollow Shaft Flat Gearhead

**BLE46AM□F-3, BLE46AM□F, BLE46CM□F-3, BLE46CM□F, BLE46SM□F-3, BLE46SM□F**

Motor: BLEM46M2-GFS

Gearhead: GFS4G□FR

Mass: 3.1 kg (6.8 lb.) (Including gearhead)

DXF A1136

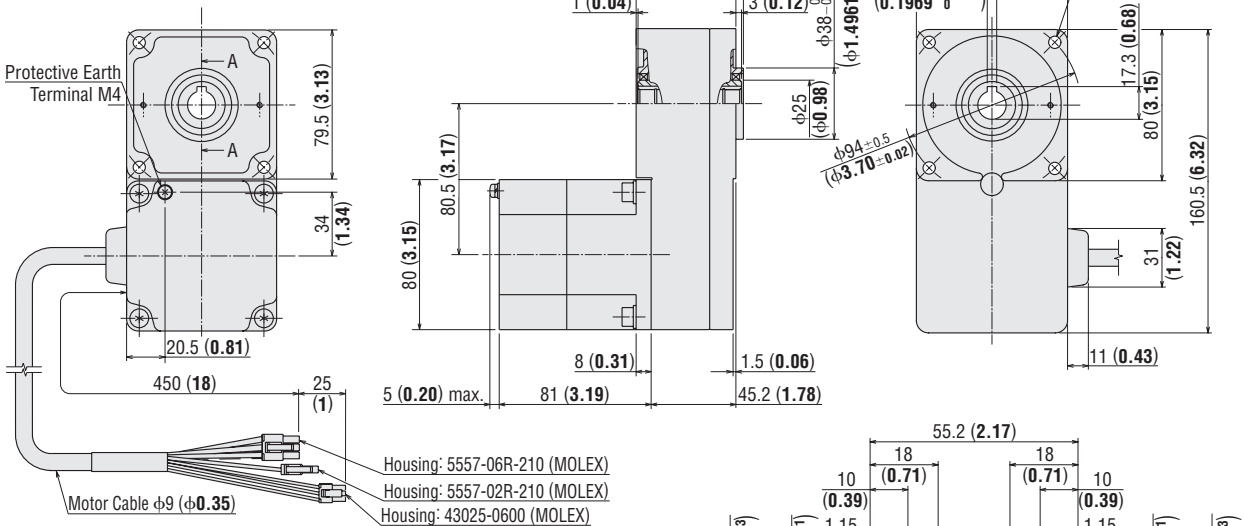

### ◇ Key (Included)

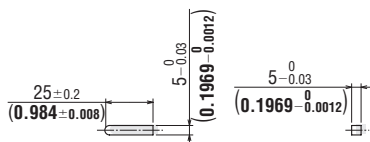

● Enter the gear ratio in the box (□) within the model name.

## ◇ Round Shaft Type

**BLE46AMA-3, BLE46AMA, BLE46CMA-3, BLE46CMA, BLE46SMA-3, BLE46SMA**

Motor: BLEM46M2-A

Mass: 1.5 kg (3.3 lb.)

**DXF** A1137

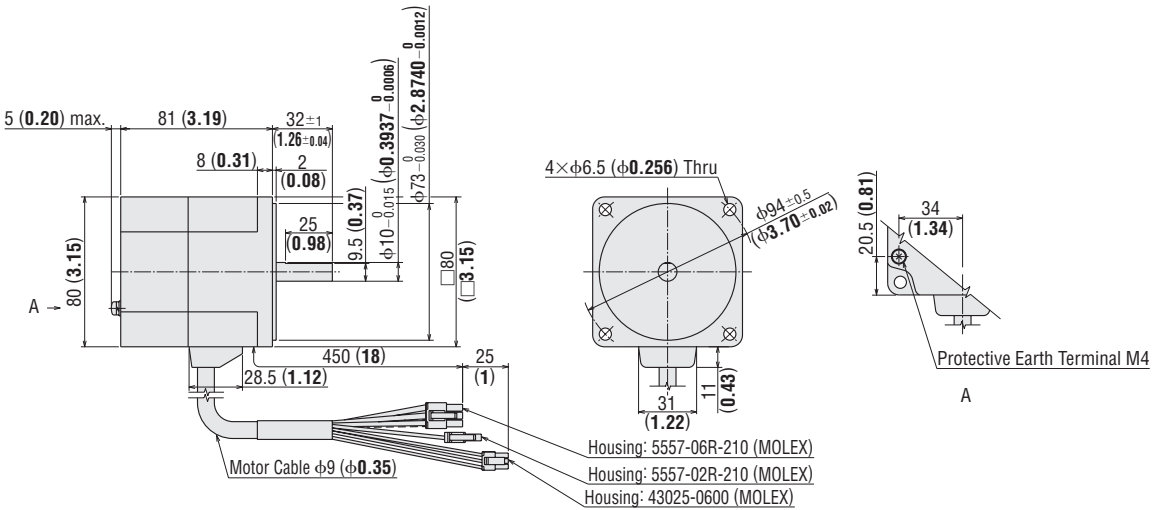

## ● With Electromagnetic Brake Type 120 W (1/6 HP)

### ◇ Motor/Parallel Shaft Gearhead

Model	Motor Model	Gearhead Model	Gear Ratio	L	Mass kg (lb.)	DXF
<b>BLE512AM□S-3, BLE512AM□S</b> <b>BLE512CM□S-3, BLE512CM□S</b> <b>BLE512SM□S-3, BLE512SM□S</b>	BLEM512M2-GFS	GFS5G□	<b>5-20</b>	45 (1.77)	3.6 (7.9)	A1093A
			<b>30-100</b>	58 (2.28)		A1093B
			<b>200</b>	64 (2.52)		A1093C

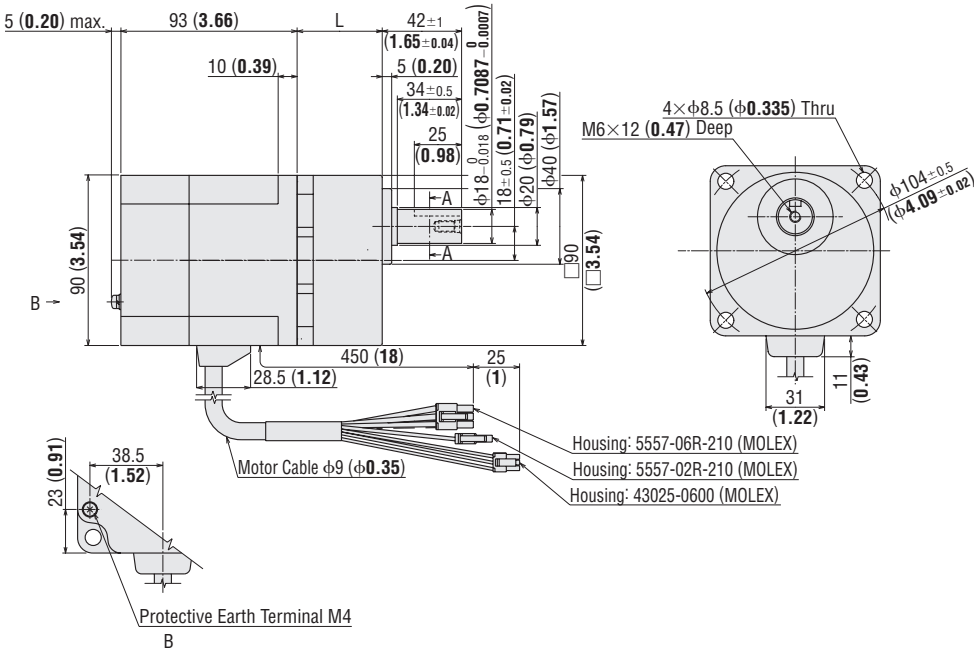

### ◇ Key and Key Slot (Included)

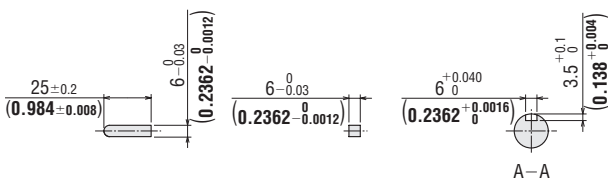

● Enter the gear ratio in the box (□) within the model name.

## ◇ Motor/Hollow Shaft Flat Gearhead

**BLE512AM□F-3, BLE512AM□F, BLE512CM□F-3, BLE512CM□F, BLE512SM□F-3, BLE512SM□F**

Motor: BLEM512M2-GFS

Gearhead: GFS5G□FR

Mass: 4.3 kg (9.5 lb.) (Including gearhead)

**DXF** A1096

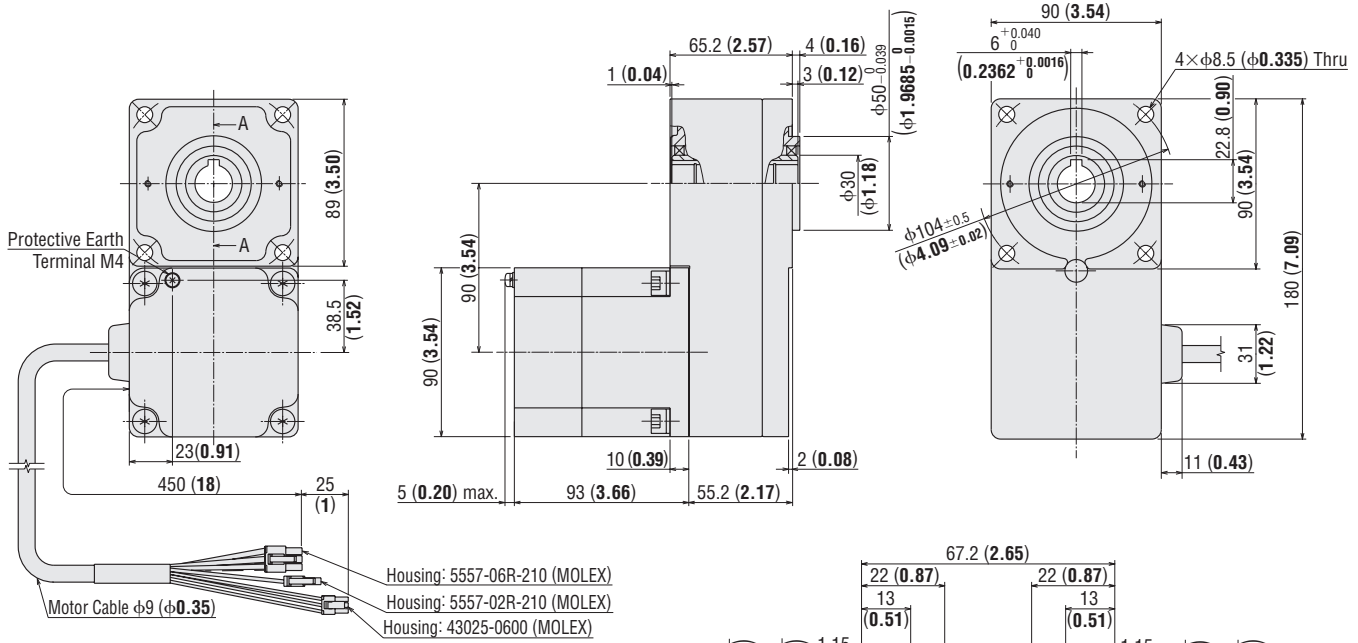

## ◇ Key (Included)

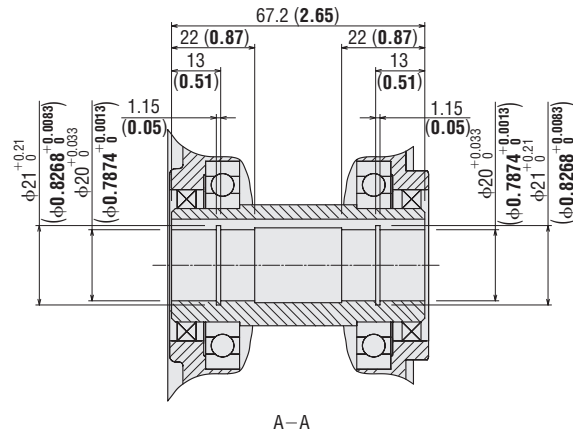
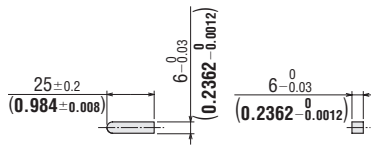

## ◇ Round Shaft Type

**BLE512AMA-3, BLE512AMA, BLE512CMA-3, BLE512CMA, BLE512SMA-3, BLE512SMA**

Motor: BLEM512M2-A

Mass: 2.1 kg (4.6 lb.)

**DXF** A1099

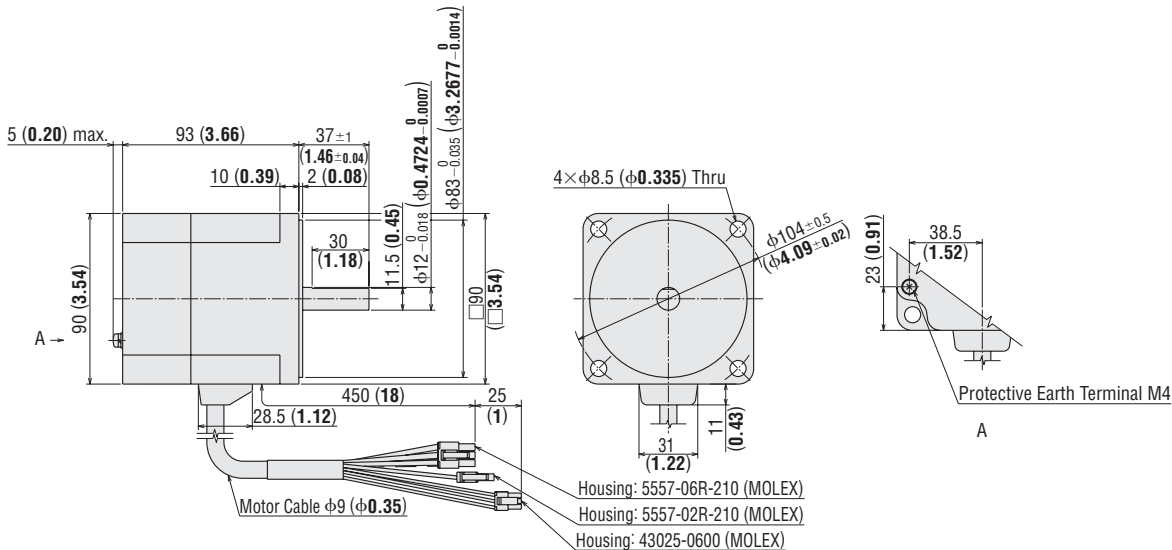

● Enter the gear ratio in the box (□) within the model name.

## ● Driver

BLED3A, BLED3C, BLED3S, BLED6A, BLED6C, BLED6S, BLED12A, BLED12C, BLED12S  
 BLED3AM, BLED3CM, BLED3SM, BLED6AM, BLED6CM, BLED6SM  
 BLED12AM, BLED12CM, BLED12SM

Mass: 0.7 kg (1.54 lb.)

**DXF** A916

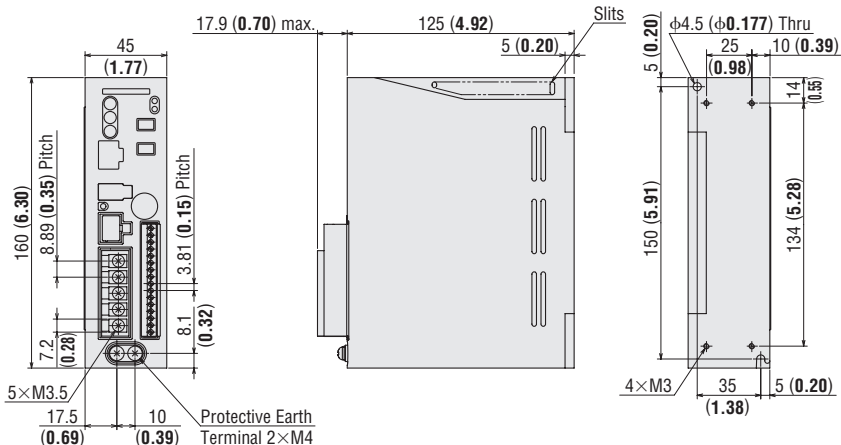

## ● Connection Cable (Included)

● Only included in connection cable unit models. Refer to Product Number Code on page D-87.

### ◇ For Standard Motors

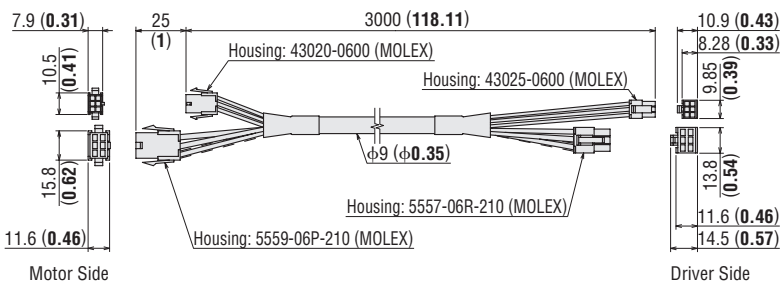

### ◇ For Electromagnetic Brake Motors

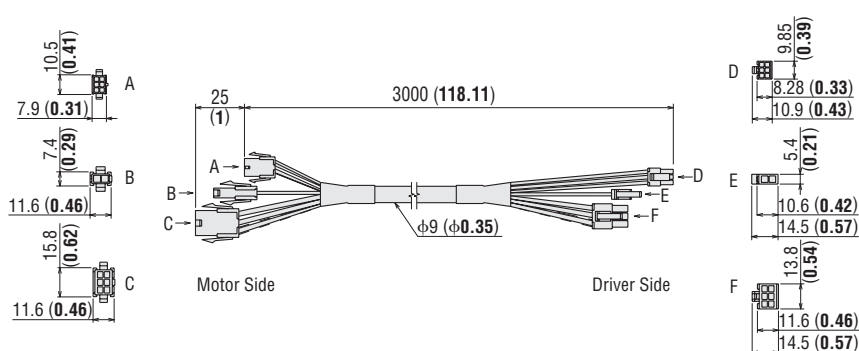

Code	Housing Model	Manufacturer
A	43020-0600	MOLEX
B	5559-02P-210	
C	5559-06P-210	
D	43025-0600	
E	5557-02R-210	
F	5557-06R-210	

## ● External Speed Potentiometer (Included)

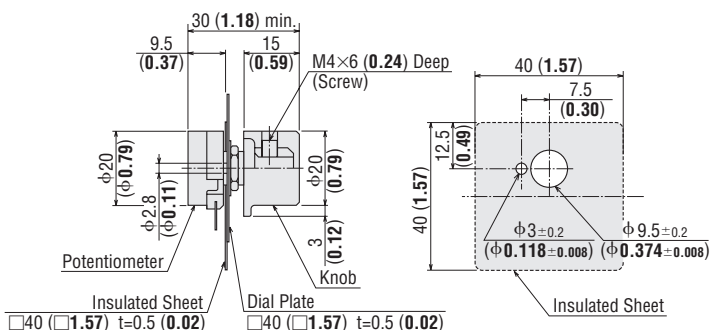

Recommended thickness of a mounting plate is a maximum of 4.5 mm (0.18 in.).

## Connection and Operation

### Names and Functions of Driver Parts

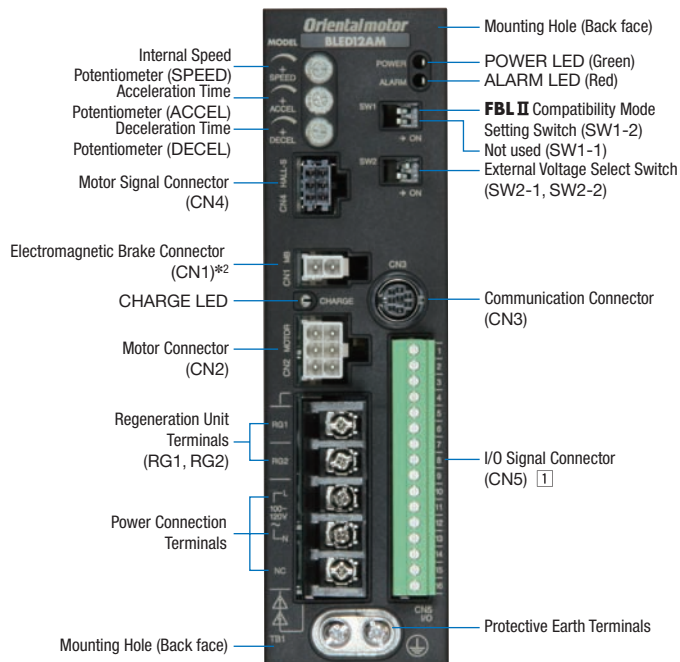

Name	Description
Internal Speed Potentiometer [SPEED]	Sets the motor speed
Acceleration Time Potentiometer [ACCEL]	Sets the acceleration time at starting of motor
Deceleration Time Potentiometer [DECEL]	Sets the deceleration time at stopping of motor
POWER LED (Green)	Lights when main power supply is on
ALARM LED (Red)	Blinks when protective functions are activated
Motor Signal Connector (CN4)	Connects the signal cable connector
<b>FBLII</b> Compatibility Mode Setting Switch (SW1)*1	SW1-1: Not used SW1-2: Sets the <b>FBLII</b> compatibility mode
External Voltage Select Switch (SW2)	SW2-1: Switches power supply for input signal Selects either external power supply or driver built-in power supply  SW2-2: Switches according to external DC voltage select either 5 VDC or 10 VDC.
Electromagnetic Brake Connector (CN1)*2	The electromagnetic brake connector of the motor cable or connection cable is connected
CHARGE LED (Red)	Lights when main power supply is on Turns off after main power supply is turned off and internal residual voltage is reduced to a stable level
Motor Connector (CN2)	Connects the cable motor connector
Regeneration Unit Connection Terminal (TB1) [RG1, RG2]	Connects the accessory regeneration unit <b>EPRC-400P</b> (sold separately)
Main Power Supply Input Terminal (TB1) [L, N] (Single-Phase Input) [L1, L2, L3] (Three-Phase Input)	Connects the main power supply ● Single-Phase 100-120 VAC: Connects single-phase 100-120 VAC to L, N ● Single-Phase 200-240 VAC: Connects single-phase 200-240 VAC to L, N ● Three-Phase 200-240 VAC: Connects three-phase 200-240 VAC to L1, L2, L3
Communication Connector (CN3)	The control module <b>OPX-2A</b> or data setting software <b>MEXE02</b> is connected
I/O Signal Connector (CN5)	Connects when external I/O signals are used
Protective Earth Terminal	Grounds with AWG18~14 (0.75~2.0 mm <sup>2</sup> ) grounding conductor

\*1 Settings can be changed to the same as the **FBLII** Series using the **FBLII** compatibility mode.

\*2 Only the electromagnetic brake type is connected.

## 1 I/O Signals

CN5 Terminal Number	Signal Type	Terminal Name	Signal Name*2	Name	Description
1	Input	C0	IN-COM0	Input Signal Common	—
2		X0	FWD	Forward Input	The motor rotates in the clockwise direction.
3		X1	REV	Reverse Input	The motor rotates in the counterclockwise direction.
4		X2	STOP-MODE	Stop Mode Selection Input	Instantaneous stop or deceleration stop is selected.
5		X3	M0	Speed Setting Selection Input	The internal speed potentiometer or external speed potentiometer (external DC voltage) is selected.
6		X4	ALARM-RESET	Alarm Reset Input	Alarms are reset.
7		X5	MB-FREE	Electromagnetic Brake Release Input	The electromagnetic brake operation is selected when the motor is stopped. Not used with the standard type.
8		X6	TH	Regeneration Unit Thermal Input	The thermostat output of a regeneration unit is connected when using the regeneration unit (normally closed).
9		VH	VH	External Speed Setting Input	Speed is set with an external speed potentiometer (external DC voltage).
10		VM	VM		
11		VL	VL		
12		C1	IN-COM1	Input Common (0 V)	—
—		—	M1*1	Speed Setting Input	For multi-speed operation, the M0, M1, and M2 signals are used in combination.
—		—	M2*1		
—		—	EXT-ERROR*1	External Error Input	When an external error signal is input, the motor stops.
13	Output	Y0+	SPEED-OUT (+)	Speed Output	30 pulses are output per each rotation of the motor output shaft. (12 pulses are output if the <b>FBLI</b> compatibility mode is used.)
14		Y0-	SPEED-OUT (-)		
15		Y1+	ALARM-OUT1 (+)	Alarm Output 1	This signal is output when an alarm is generated (normally closed). (Normally open if the <b>FBLI</b> compatibility mode is used.)
16		Y1-	ALARM-OUT1 (-)		
—		—	MOVE*1	Motor Running Output	This signal is output during motor rotation.
—		—	VA*1	Speed Attainment Output	This signal is output if the motor speed reaches a speed within the speed attainment range that has been set.
—		—	ALARM-OUT2*1	Alarm Output 2	This signal is output when the overload warning level is exceed when the overload warning function is set to enable. In addition, also outputs if an overload alarm is generated even when the overload warning function is set to disable (normally closed).
—		—	WNG*1	Warning Output	This signal is output if a warning is generated (overload warning function is activated). While, it turns OFF if the warning is released.
—	—	TLC*1	Torque Limit Output	This signal is output when the motor output torque reaches the torque limiting value.	

\*1 The control module (sold separately) may be used to extend the functions.

\*2 The control module (sold separately) may be used to assign the required signals out of the seven input terminals (X0 to X6) and the two output signal terminals (Y0 and Y1).

7 types for the 10 types of input signals (FWD/REV/STOP-MODE/M0/ALARM-RESET/MB-FREE/TH/M1/M2/EXT-ERROR)

2 types for the 7 types of output signals (SPEED-OUT/ALARM-OUT1/MOVE/VA/ALARM-OUT2/WNG/TLC)



## ● Connection Diagram

The figure shows a connection example for when a single-phase 100-120 VAC internal power supply and an external speed potentiometer are used to set speed.

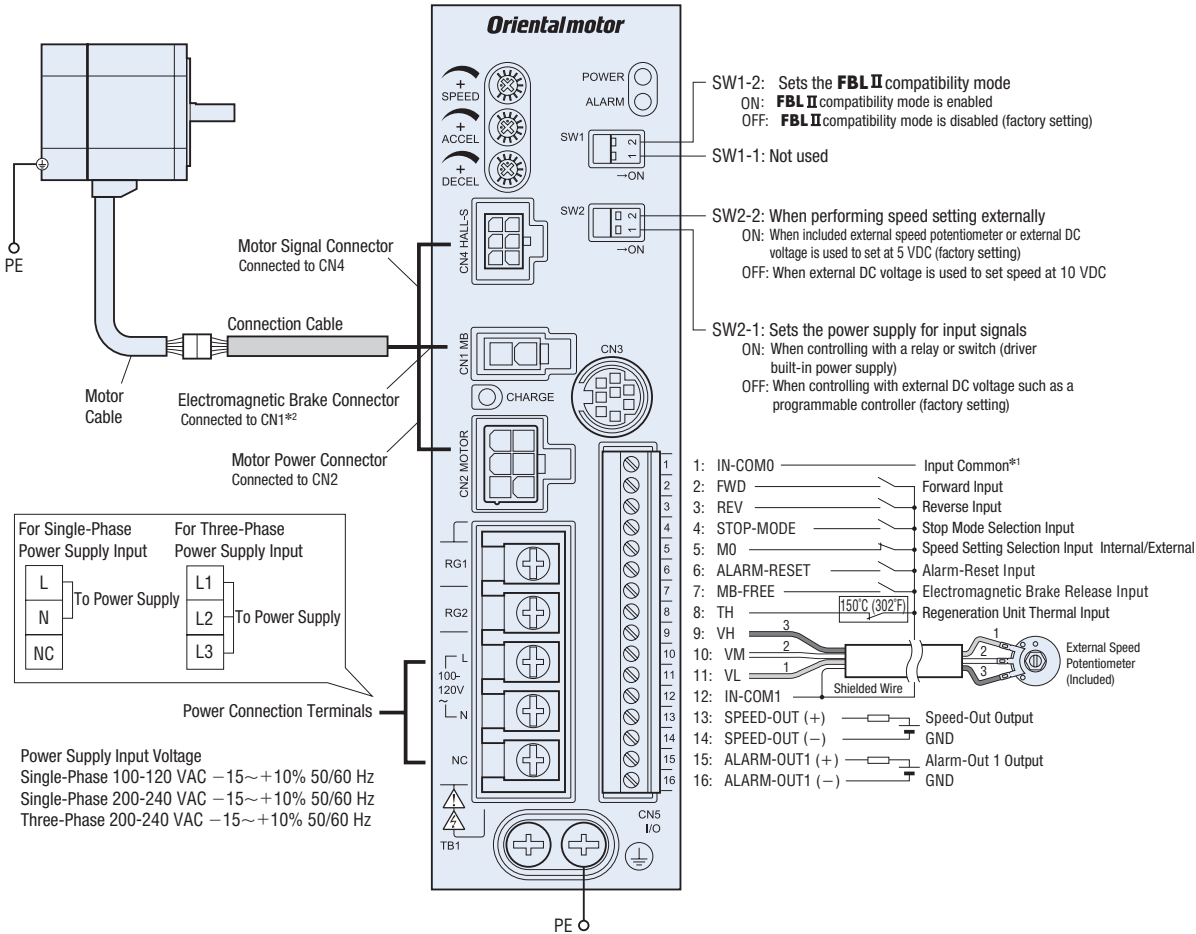

\*1 When a built-in power supply is used, connection is not necessary.  
 \*2 Only the electromagnetic brake type is connected.

## ◇ Applicable Crimp Terminals

### ● Power Supply Connection Terminals (M3.5): Round Terminal with Insulation

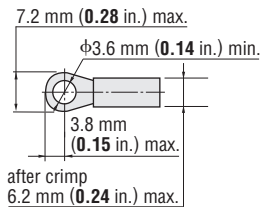

### ● Protective Earth Terminals (M4): Round Terminal with Insulation

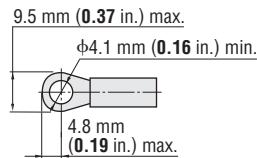

### ● I/O Terminals

Use the terminals specified below for connection using crimp terminals. Please note that the applicable crimp terminal will vary depending on the size of the wire. The following terminals can be used with wires of AWG24 to 20 in size.

- [Manufacturer: PHOENIX CONTACT Inc.]  
 AI 0.25-6 Applicable Cable Size: AWG24 (0.2 mm<sup>2</sup>)  
 AI 0.34-6 Applicable Cable Size: AWG22 (0.3 mm<sup>2</sup>)  
 AI 0.5-6 Applicable Cable Size: AWG20 (0.5 mm<sup>2</sup>)

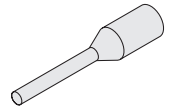

## ● Timing Chart

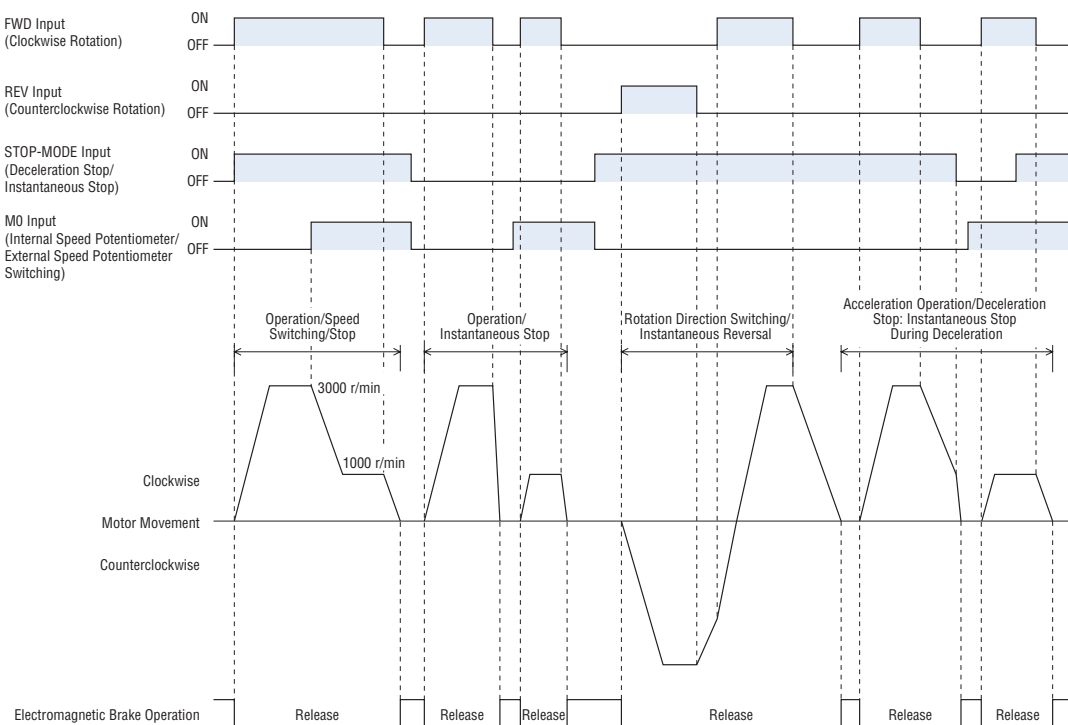

- FWD input, REV input and STOP-MODE input can be used to control all operations, such as run, stop, rotation direction switching, deceleration stop and instantaneous stop.
- Switching the FWD input to ON will cause the motor to turn clockwise as viewed from the motor shaft, while switching the REV input to ON will cause the motor to turn counterclockwise. Switching each signal OFF will stop the motor. If both the FWD input and REV input are turned ON simultaneously, the motor will stop instantaneously. The starting time is the time set by the acceleration time potentiometer (ACCEL).
- If STOP-MODE input is turned ON, the motor comes to deceleration stop over the time set by the deceleration time potentiometer (DECEL). Switching the STOP-MODE input to OFF will cause the motor to stop instantaneously.
- For electromagnetic brake types, the brakes operate at the same time the motor comes to a standstill.

## ● Input/Output Signal Circuits

Select sink logic or source logic according to the external control device you will be using.

### ◇ Input Circuit

FWD/REV-MODE/M0/ALARM-RESET/MB-FREE/TH (M1\*/M2\*/EXT-ERROR\*)

\* Asterisked items indicate control module (sold separately) use

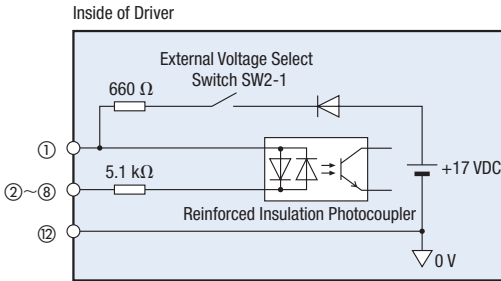

### ◇ Connection to Programmable Controller

#### ● Sink Logic

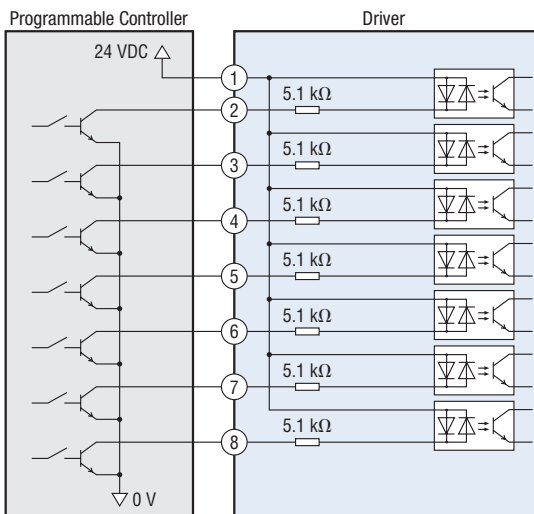

#### ● Source Logic

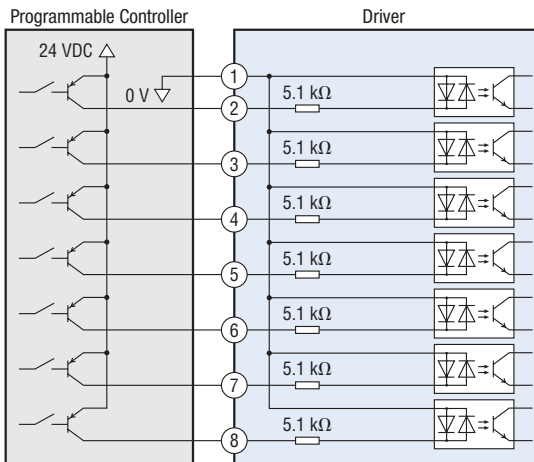

### ◇ Output Circuit

SPEED-OUT/ALARM-OUT1/(MOVE\*/VA\*/ALARM-OUT2\*/WNG\*/TLC\*)

\* Asterisked items indicate control module (sold separately) use

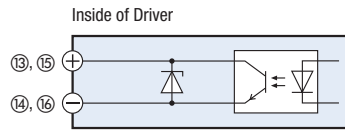

### ◇ Programmable Controller Connection Examples

#### ● Sink Logic

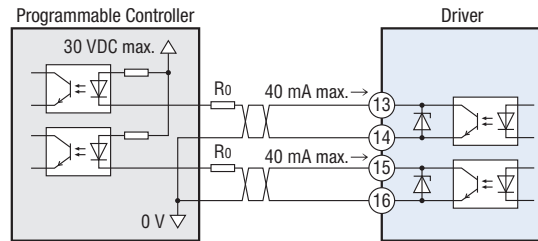

#### ● Source Logic

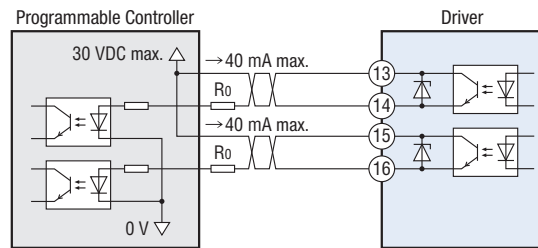

### ◇ When an External Control Device with a Built-In Clamp Diode is Used

When an external control device with a built-in clamp diode is used, if the power is being supplied to the driver, current may flow and cause the motor to run, even if the power supply of the external control device is off. When the power supply is turned ON or OFF simultaneously, the motor may run temporarily due to differences in power supply capacity. The external control device power supply must be turned ON first, and driver power supply must be turned OFF first.

#### ● Example of Sink Logic

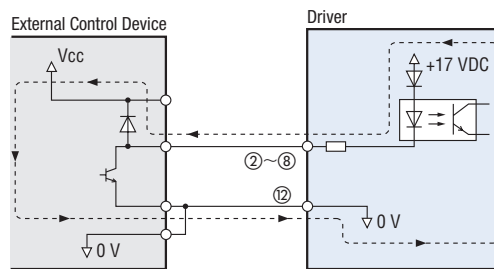

## ◇ Speed Output (SPEED-OUT)

Pulse signals of 30 pulses (Pulse Width: 0.2 ms) are output per each rotation of the motor output shaft in synchronization with the motor operation.

You can measure the speed output frequency and calculate the motor speed.

$$\text{Speed Output Frequency (Hz)} = \frac{1}{T}$$

$$\text{Motor Shaft Speed (r/min)} = \frac{\text{Speed Output Frequency}}{30} \times 60$$

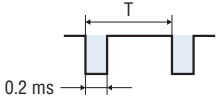

- To display or monitor the speed of the output shaft of the motor and gearhead, use the accessory **SDM496** motor speed indicator (sold separately).  
Motor speed indicator → Page D-234

## ◇ Alarm Output 1 (ALARM-OUT 1)

When any of the driver's protective functions is activated, alarm output turns OFF and the alarm LED will blink. The motor will coast to a stop.

## ● Speed Setting Methods

### ◇ Set Speeds Using the Internal Speed Potentiometer

When setting is performed with the internal speed potentiometer, set the M0 input to OFF.

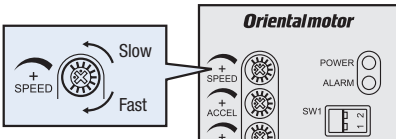

### ◇ Set Speeds Using an External Speed Potentiometer

Connect the included external speed potentiometer to the I/O signal connector (CN5).

For connection, use the included signal line [1 m (3.3 ft.)].

When setting is performed with the external speed potentiometer, set the M0 input to ON.

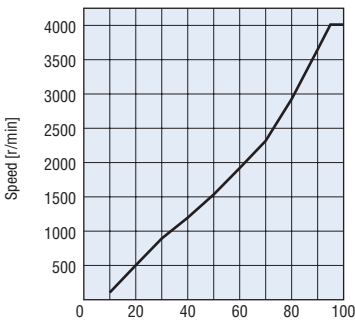
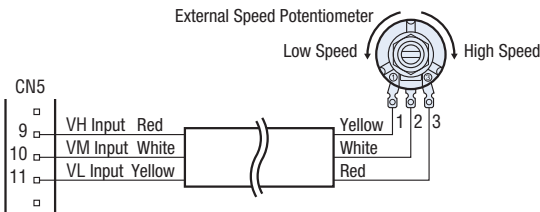

External Speed Potentiometer Scale – Speed Characteristics (Representative values)

### Note

- The speed in the graph represents the speed of a motor alone. The gearhead output shaft speed of the combination type is calculated by dividing the graph speed by the gear ratio.

## ◇ Set Speeds Using External DC Voltage

Set the external voltage select switch on the driver in accordance with the external DC voltage to be supplied. Switch it to 5 VDC or 10 VDC.

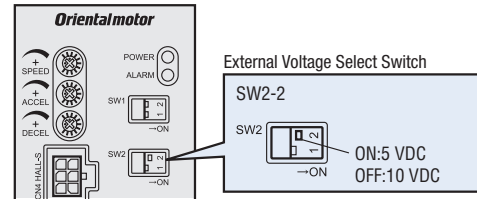

Use external DC voltage and connect to the I/O signal connector (CN5) using the included signal line [1 m (3.3 ft.)].

When setting is performed with the external DC voltage, set the M0 input to ON.

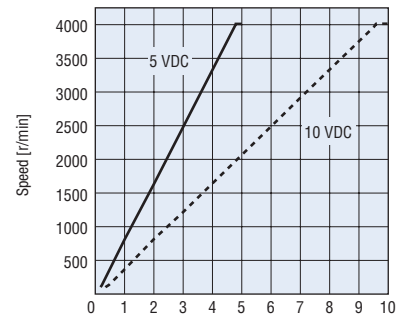
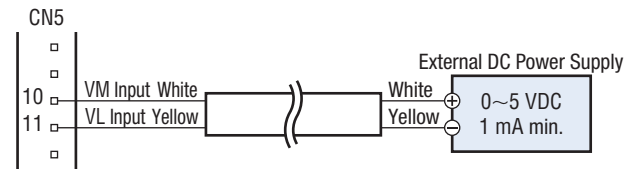

External DC Voltage – Speed Characteristics (Representative values)

### Note

- The speed in the graph represents the speed of a motor alone. The gearhead output shaft speed of the combination type is calculated by dividing the graph speed by the gear ratio.

## ● Multi-Motor Control

When you want to operate two or more sets of motors and drivers at the same speed by using a single speed potentiometer, you need to use an external speed potentiometer or external DC voltage.

The figure below shows an example of the single-phase power supply specification. For three-phase power supply specification, change the power supply line to three-phase power supply. The motor and operation control unit are not illustrated in the figure.

### ◇ When Using an External Speed Potentiometer

Connect all drivers using a common power supply line and common speed control line, as shown in the figure, and set a speed using the external speed potentiometer VRx.

The resistance value of the external speed potentiometer is determined using the formula below.

Resistance value when the number of drivers is n:

$$VRx = 20/n \text{ (k}\Omega\text{)}, n/4 \text{ (W)}$$

Example: When two drivers are connected

$$VRx = 20/2 = 10 \text{ (k}\Omega\text{)}, 2/4 = 1/2 \text{ (W)}$$

Resistance is 10 kΩ, 1/2 W

To adjust the speed difference among the motors, connect a resistor of 470 Ω, 1/4 W to the VM terminal on the first driver and connect a potentiometer of 1 kΩ, 1/4 W (VRn) to the VM terminal on each of the remaining drivers.

Twenty motors or less can be operated in parallel using an external speed potentiometer.

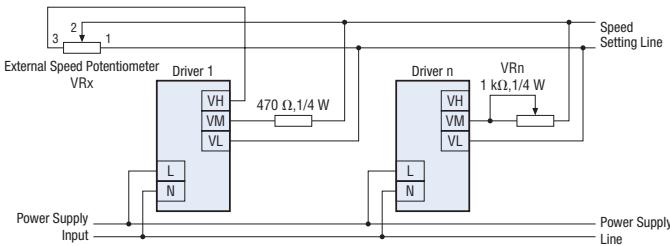

### ◇ When Using an External DC Voltage

Connect all drivers using a common power supply line and common speed control line, as shown in the figure, and connect a 5 VDC or 10 VDC power supply.

The power supply capacity of the external DC power supply is determined as follows:

Power supply capacity when the number of drivers is n:  $I = 1 \times n \text{ (mA)}$

Example: When two drivers are connected

$$I = 1 \times 2 = 2 \text{ (mA)}$$

Power supply capacity is 2 mA or more

To adjust the speed difference among the motors, connect a resistor of 470 Ω, 1/4 W to the VM terminal on the first driver, and connect a potentiometer of 1 kΩ, 1/4 W (VRn) to the VM terminal on each of the remaining drivers.

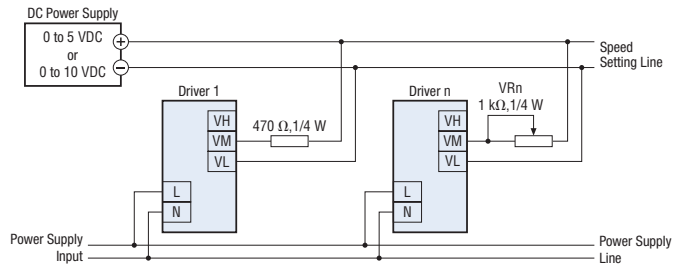

## List of Motor and Driver Combinations

### ● Standard Type

#### ◇ Combination Type – Parallel Shaft Gearhead

The combination type comes with the motor and parallel shaft gearhead pre-assembled.

Output Power	Model	Motor Model	Gearhead Model	Driver Model
30 W (1/25 HP)	BLE23A□S-3 BLE23A□S	BLEM23-GFS	GFS2G□	BLED3A
	BLE23C□S-3 BLE23C□S			BLED3C
	BLE23S□S-3 BLE23S□S			BLED3S
60 W (1/12 HP)	BLE46A□S-3 BLE46A□S	BLEM46-GFS	GFS4G□	BLED6A
	BLE46C□S-3 BLE46C□S			BLED6C
	BLE46S□S-3 BLE46S□S			BLED6S
120 W (1/6 HP)	BLE512A□S-3 BLE512A□S	BLEM512-GFS	GFS5G□	BLED12A
	BLE512C□S-3 BLE512C□S			BLED12C
	BLE512S□S-3 BLE512S□S			BLED12S

#### ◇ Combination Type – Hollow Shaft Flat Gearhead

The combination type comes with the motor and hollow shaft flat gearhead pre-assembled.

Output Power	Model	Motor Model	Gearhead Model	Driver Model
30 W (1/25 HP)	BLE23A□F-3 BLE23A□F	BLEM23-GFS	GFS2G□FR	BLED3A
	BLE23C□F-3 BLE23C□F			BLED3C
	BLE23S□F-3 BLE23S□F			BLED3S
60 W (1/12 HP)	BLE46A□F-3 BLE46A□F	BLEM46-GFS	GFS4G□FR	BLED6A
	BLE46C□F-3 BLE46C□F			BLED6C
	BLE46S□F-3 BLE46S□F			BLED6S
120 W (1/6 HP)	BLE512A□F-3 BLE512A□F	BLEM512-GFS	GFS5G□FR	BLED12A
	BLE512C□F-3 BLE512C□F			BLED12C
	BLE512S□F-3 BLE512S□F			BLED12S

#### ◇ Round Shaft Type

Output Power	Model	Motor Model	Driver Model
30 W (1/25 HP)	BLE23AA-3 BLE23AA	BLEM23-A	BLED3A
	BLE23CA-3 BLE23CA		BLED3C
	BLE23SA-3 BLE23SA		BLED3S
60 W (1/12 HP)	BLE46AA-3 BLE46AA	BLEM46-A	BLED6A
	BLE46CA-3 BLE46CA		BLED6C
	BLE46SA-3 BLE46SA		BLED6S
120 W (1/6 HP)	BLE512AA-3 BLE512AA	BLEM512-A	BLED12A
	BLE512CA-3 BLE512CA		BLED12C
	BLE512SA-3 BLE512SA		BLED12S

### ● With Electromagnetic Brake Type

#### ◇ Combination Type – Parallel Shaft Gearhead

The combination type comes with the motor and parallel shaft gearhead pre-assembled.

Output Power	Model	Motor Model	Gearhead Model	Driver Model
30 W (1/25 HP)	BLE23AM□S-3 BLE23AM□S	BLEM23M2-GFS	GFS2G□	BLED3AM
	BLE23CM□S-3 BLE23CM□S			BLED3CM
	BLE23SM□S-3 BLE23SM□S			BLED3SM
60 W (1/12 HP)	BLE46AM□S-3 BLE46AM□S	BLEM46M2-GFS	GFS4G□	BLED6AM
	BLE46CM□S-3 BLE46CM□S			BLED6CM
	BLE46SM□S-3 BLE46SM□S			BLED6SM
120 W (1/6 HP)	BLE512AM□S-3 BLE512AM□S	BLEM512M2-GFS	GFS5G□	BLED12AM
	BLE512CM□S-3 BLE512CM□S			BLED12CM
	BLE512SM□S-3 BLE512SM□S			BLED12SM

#### ◇ Combination Type – Hollow Shaft Flat Gearhead

The combination type comes with the motor and hollow shaft flat gearhead pre-assembled.

Output Power	Model	Motor Model	Gearhead Model	Driver Model
30 W (1/25 HP)	BLE23AM□F-3 BLE23AM□F	BLEM23M2-GFS	GFS2G□FR	BLED3AM
	BLE23CM□F-3 BLE23CM□F			BLED3CM
	BLE23SM□F-3 BLE23SM□F			BLED3SM
60 W (1/12 HP)	BLE46AM□F-3 BLE46AM□F	BLEM46M2-GFS	GFS4G□FR	BLED6AM
	BLE46CM□F-3 BLE46CM□F			BLED6CM
	BLE46SM□F-3 BLE46SM□F			BLED6SM
120 W (1/6 HP)	BLE512AM□F-3 BLE512AM□F	BLEM512M2-GFS	GFS5G□FR	BLED12AM
	BLE512CM□F-3 BLE512CM□F			BLED12CM
	BLE512SM□F-3 BLE512SM□F			BLED12SM

#### ◇ Round Shaft Type

Output Power	Model	Motor Model	Driver Model
30 W (1/25 HP)	BLE23AMA-3 BLE23AMA	BLEM23M2-A	BLED3AM
	BLE23CMA-3 BLE23CMA		BLED3CM
	BLE23SMA-3 BLE23SMA		BLED3SM
60 W (1/12 HP)	BLE46AMA-3 BLE46AMA	BLEM46M2-A	BLED6AM
	BLE46CMA-3 BLE46CMA		BLED6CM
	BLE46SMA-3 BLE46SMA		BLED6SM
120 W (1/6 HP)	BLE512AMA-3 BLE512AMA	BLEM512M2-A	BLED12AM
	BLE512CMA-3 BLE512CMA		BLED12CM
	BLE512SMA-3 BLE512SMA		BLED12SM

● Enter the gear ratio in the box (□) within the model name.

## Brushless Motors/AC Speed Control Motors

# Accessories

	<u>Page</u>
Cables.....	D-226
External Speed Potentiometer.....	D-230
Regeneration Units.....	D-231
Remote-Control kit.....	D-232
Data Setting Software.....	D-232
Control Modules.....	D-233
Motor Speed Indicator.....	D-234
DIN Rail Mounting Plates.....	D-236
Front Cover.....	D-237
Motor/Gearhead Mounting Brackets.....	D-238
Flexible Couplings.....	D-238

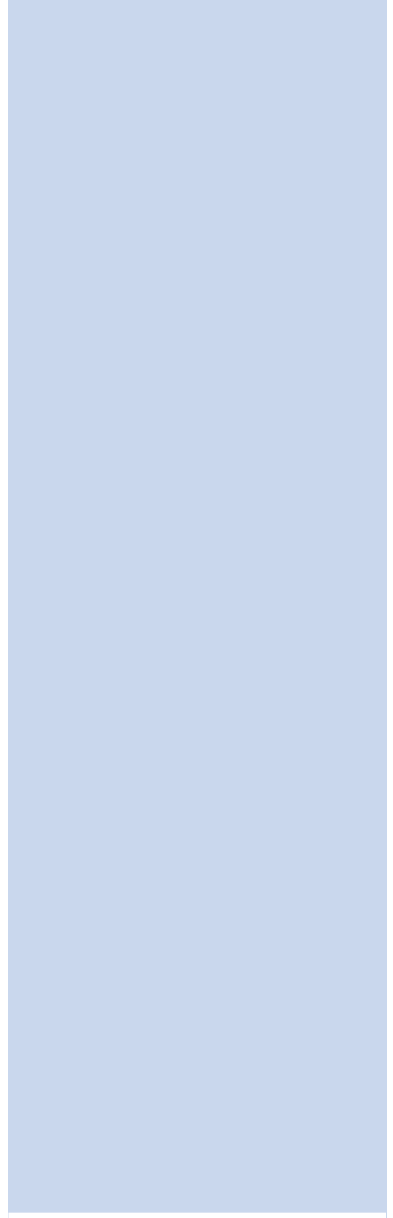

## Accessories

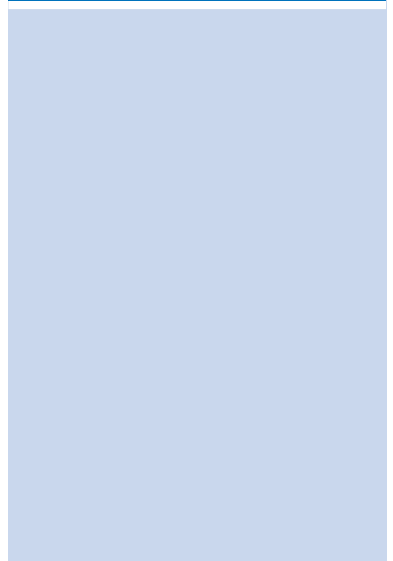

Introduction	
AC Input	Brushless Motors
BX	
BLF	
BLE	
BLU	
BLH	DC Input
BLV	
BHIF	AC Speed Control Motors
FE100/ FE200	
ES01/ ES02	
US	
Accessories	
Installation	

# Cables

## ■ Connection Cables for BX Series (RoHS)

These cables are used to extend the wiring distance between the motor and driver. The maximum extension length is 20.4 m (66.9 ft.). Use the flexible connection cable in applications where the cable is bent and flexed. All connection cables and flexible connection cables come as a set of motor and encoder cables.

### ● Cable System Configuration

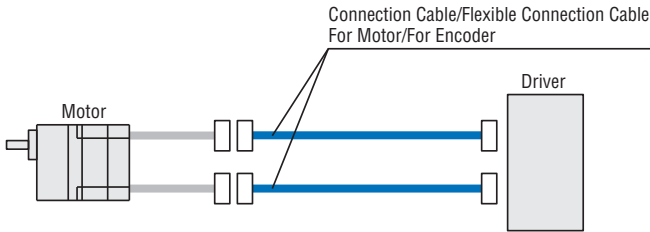

### ● Product Line

#### ◇ Connection Cables (CC\_SBF)



Model	Length L [m (ft.)]
CC01SBF	1 (3.3)
CC02SBF	2 (6.6)
CC03SBF	3 (9.8)
CC05SBF	5 (16.4)
CC07SBF	7 (23.0)
CC10SBF	10 (32.8)
CC15SBF	15 (49.2)
CC20SBF	20 (65.6)

#### ◇ Flexible Connection Cables (CC\_SBR)

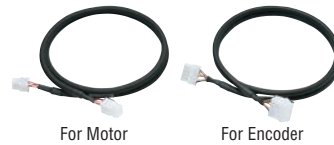

Model	Length L [m (ft.)]
CC01SBR	1 (3.3)
CC02SBR	2 (6.6)
CC03SBR	3 (9.8)
CC05SBR	5 (16.4)
CC07SBR	7 (23.0)
CC10SBR	10 (32.8)
CC15SBR	15 (49.2)
CC20SBR	20 (65.6)

### ● Dimensions Unit = mm (in.)

#### ◇ For Motor

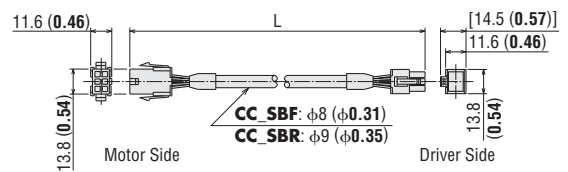

#### ◇ For Encoder

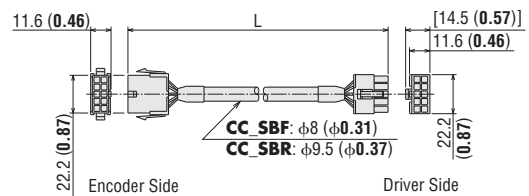

## ■ Notes on Use of Flexible Connection Cables

① Do not allow the cable to bend at the cable connector.

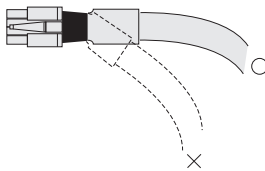

② For the bending radius, use at six times or more of the cable diameter.

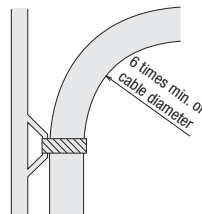

③ Connection cables are not flexible. If regularly bending of the cable is required, use the flexible cable only (sold separately).

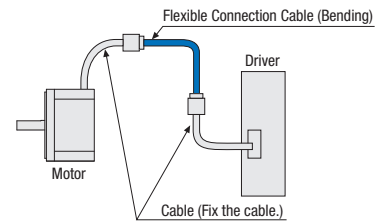



## Connection Cables for BLF Series (RoHS)

These cables are used to extend the wiring distance between the motor and driver. The maximum extension length is 20.4 m (66.9 ft.).

### Cable System Configuration

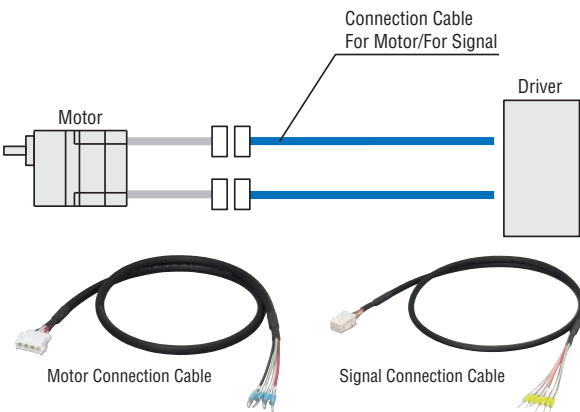

### Product Line

The cable set consists of two cables including a motor connection cable and a signal connection cable.

Model	Length L [m (ft.)]
CC01BLF	1 (3.3)
CC02BLF	2 (6.6)
CC03BLF	3 (9.8)
CC05BLF	5 (16.4)
CC07BLF	7 (23.0)
CC10BLF	10 (32.8)
CC15BLF	15 (49.2)
CC20BLF	20 (65.6)

### Dimensions Unit = mm (in.)

#### Motor Connection Cable L: 1 to 7 m (3.3 to 23.0 ft.)

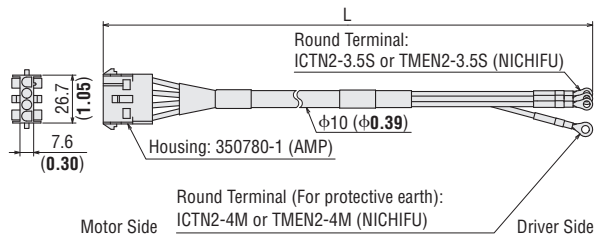

#### Motor Connection Cable L: 10 to 20 m (32.8 to 65.6 ft.)

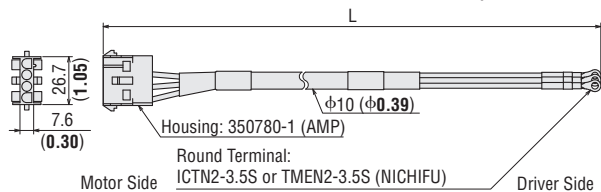

#### Signal Connection Cable

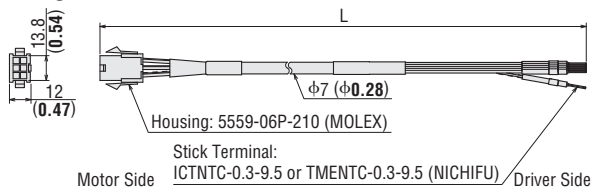

## ■ Connection Cables for BLE Series (RoHS)

The **BLE** series is available with or without a 3 m (9.8 ft.) connection cable for motor and driver connection.  
 When the distance between the motor and the driver is extended, the accessory (sold separately) connection cable must be used.  
 Use the accessory (sold separately) flexible connection cable in applications where the cable is bent and flexed.

### ● Cable System Configuration

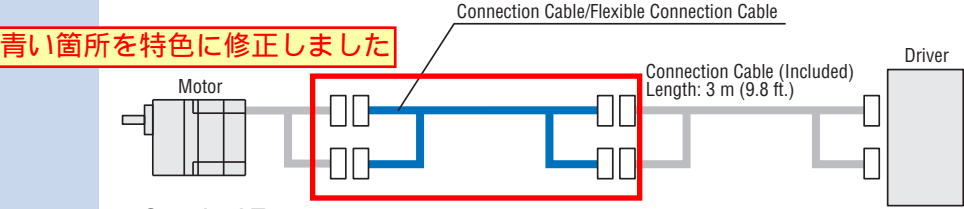

### ● Standard Type

#### ◇ Connection Cables (CC\_BLE)

Model	Length L [m (ft.)]
CC01BLE	1 (3.3)
CC02BLE	2 (6.6)
CC03BLE	3 (9.8)
CC05BLE	5 (16.4)
CC07BLE	7 (23.0)
CC10BLE	10 (32.8)
CC15BLE	15 (49.2)
CC20BLE	20 (65.6)

#### ◇ Flexible Connection Cables (CC\_BLER)

Model	Length L [m (ft.)]
CC01BLER	1 (3.3)
CC02BLER	2 (6.6)
CC03BLER	3 (9.8)
CC05BLER	5 (16.4)
CC07BLER	7 (23.0)
CC10BLER	10 (32.8)
CC15BLER	15 (49.2)
CC20BLER	20 (65.6)



Connection Cables



Flexible Connection Cables

● Notes on use of flexible connection cables → Page D-226

#### Note

● When connecting the connection cable, keep the overall length of the cable at 20 m (65.6 ft.) or less (maximum 3 cables).

#### ◇ Dimensions Unit = mm (in.)

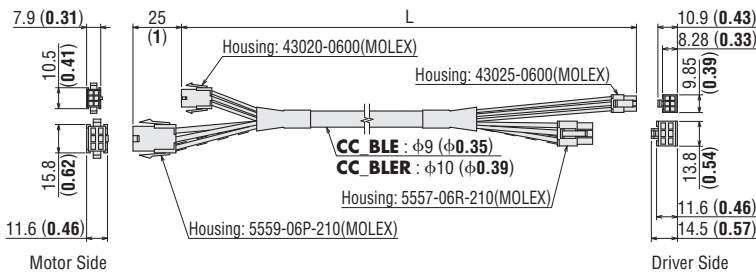

### ● With Electromagnetic Brake Type

#### ◇ Connection Cables (CC\_BLEM)

Model	Length L [m (ft.)]
CC01BLEM	1 (3.3)
CC02BLEM	2 (6.6)
CC03BLEM	3 (9.8)
CC05BLEM	5 (16.4)
CC07BLEM	7 (23.0)
CC10BLEM	10 (32.8)
CC15BLEM	15 (49.2)
CC20BLEM	20 (65.6)

#### ◇ Flexible Connection Cables (CC\_BLEMR)

Model	Length L [m (ft.)]
CC01BLEMR	1 (3.3)
CC02BLEMR	2 (6.6)
CC03BLEMR	3 (9.8)
CC05BLEMR	5 (16.4)
CC07BLEMR	7 (23.0)
CC10BLEMR	10 (32.8)
CC15BLEMR	15 (49.2)
CC20BLEMR	20 (65.6)



Connection Cables



Flexible Connection Cables

● Notes on use of flexible connection cables → Page D-226

#### Note

● When connecting the connection cable, keep the overall length of the cable at 20 m (65.6 ft.) or less (maximum 3 cables).

#### ◇ Dimensions Unit = mm (in.)

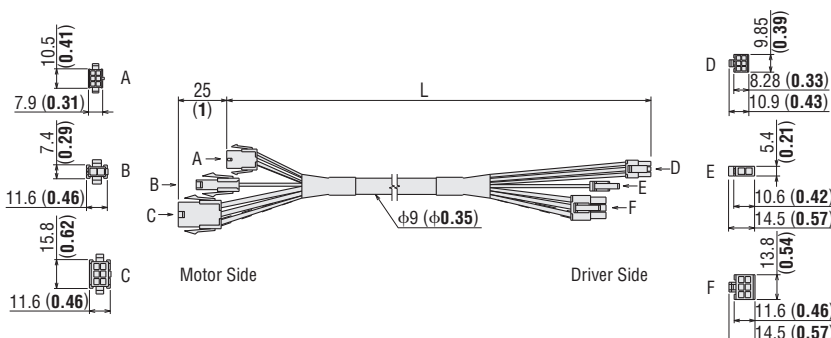

Code	Housing Model	Manufacturer
A	43020-0600	MOLEX
B	5559-02P-210	MOLEX
C	5559-06P-210	MOLEX
D	43025-0600	MOLEX
E	5557-02R-210	MOLEX
F	5557-06R-210	MOLEX

## Connection Cables for BLU Series (RoHS)

These cables are used to extend the wiring distance between the motor and driver. The maximum extension length is 10.5 m (34.4 ft.). Use the flexible connection cable in applications where the cable is bent and flexed.

### 1 Connection Cables

#### Product Line (CC\_AXU)



Model	Length L [m (ft.)]
<b>CC01AXU</b>	1 (3.3)
<b>CC02AXU</b>	2 (6.6)
<b>CC03AXU</b>	3 (9.8)
<b>CC05AXU</b>	5 (16.4)
<b>CC10AXU</b>	10 (32.8)

### 2 Flexible Connection Cables

#### Product Line (CC\_BLUR)



Model	Length L [m (ft.)]
<b>CC01BLUR</b>	1 (3.3)
<b>CC02BLUR</b>	2 (6.6)
<b>CC03BLUR</b>	3 (9.8)
<b>CC05BLUR</b>	5 (16.4)
<b>CC10BLUR</b>	10 (32.8)

● Notes on use of flexible connection cables → Page D-226

#### Dimensions Unit = mm (in.)

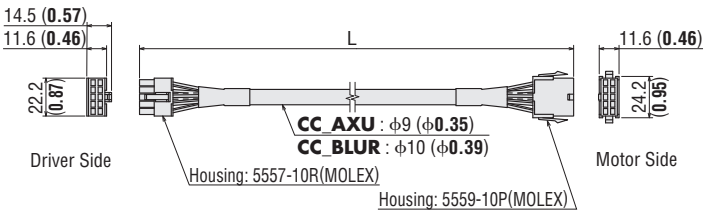

## Connection Cables for BLH Series (RoHS)

These cables are used to extend the wiring distance between the motor and driver. The maximum extension length is 2 m (6.6 ft.). Use the flexible connection cable in applications where the cable is bent and flexed.

### 1 Connection Cables

#### Product Line



Applicable Products	Model
<b>BLH015</b>	<b>CC02BLH</b>
<b>BLH230</b>	
<b>BLH450</b>	
<b>BLH5100</b>	<b>CC02AXH2</b>

#### Dimensions Unit = mm (in.)

##### BLH015/BLH230/BLH450

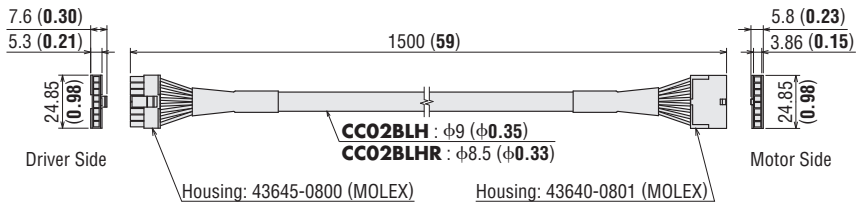

##### BLH5100

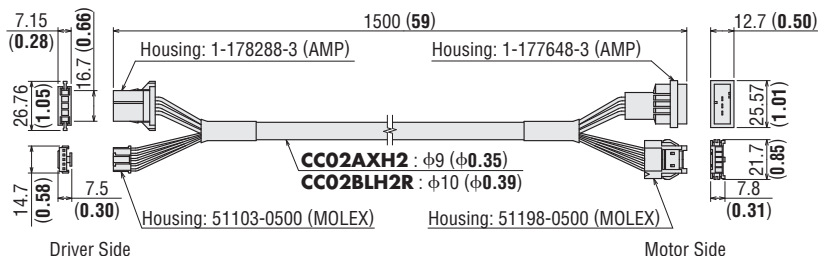

### 2 Flexible Connection Cables

#### Product Line



Applicable Products	Model
<b>BLH015</b>	<b>CC02BLHR</b>
<b>BLH230</b>	
<b>BLH450</b>	
<b>BLH5100</b>	<b>CC02BLH2R</b>

● Notes on use of flexible connection cables → Page D-226

## ■ Connection Cables for FE100/FE200, BHF Series RoHS

These cables are used to extend the wiring distance between the motor and speed controller.

### ● Cable System Configuration

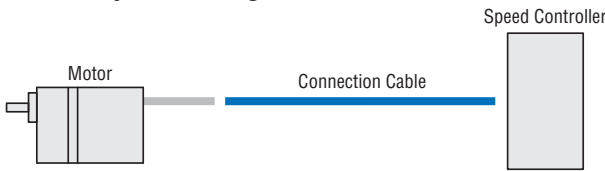

### ● Product Line

Speed Controller	Model	Cable Length L [m (ft.)]
FE100/FE200 BHF Series*	CC01AC04	1 (3.3)
	CC02AC04	2 (6.6)
	CC03AC04	3 (9.8)
	CC05AC04	5 (16.4)
	CC10AC04	10 (32.8)
	CC20AC04	20 (65.6)

Outer sheath: Oil-resistant and heat-resistant vinyl chloride

\* Excluding BHF series electromagnetic brake types.

### ● Dimensions Unit = mm (in.)

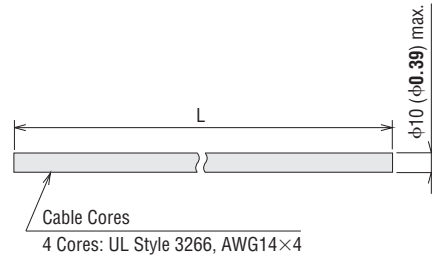

## External Speed Potentiometer RoHS

This is a potentiometer used for setting the speed control motor.

### ■ Product Line

(20 kΩ 1/4 W, with a linear resistance vs. angle curve)

Model	Applicable Products
PAVR-20KZ	BX Series*1
	BLF Series*2
	BLE Series*1
	BLH Series*2
	ES01/ES02*1
	BHF Series*2

#### Notes

\*1 One external speed potentiometer set is included.

Use when setting the speed in multiple stages.

\*2 The external speed potentiometer is not included.

Use when setting the speed with the external speed potentiometer.

### ■ Dimensions Unit = mm (in.)

Mass: 20 g (0.71 oz.)

DXF A714

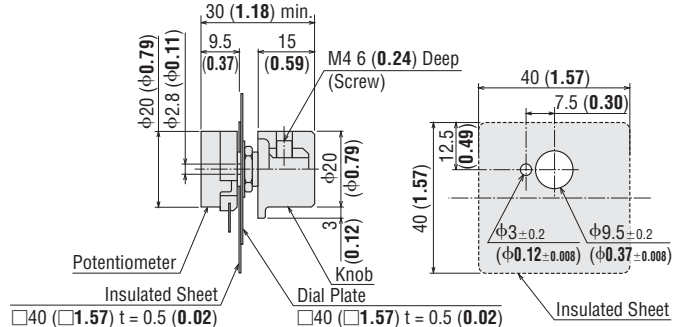

Recommended thickness of a mounting plate is a maximum of 4.5 mm (0.18 in.).



## Regeneration Units RoHS

During vertical drive (gravitational operation) and when starting and stopping large inertia loads rapidly, external forces cause the motor to rotate and function as a power generator. When that occurs, if the regenerative power exceeds the capacity of the driver to absorb, failure may result. In such cases, the regeneration unit is connected to the driver and the regenerative power is released as heat energy.

### Product Line

Model	Applicable Products
<b>EPRC-400P</b>	<b>BX230, BX460, BX5120</b>
	<b>BLE Series</b>
	<b>BHF Series</b>
<b>RGB100</b>	<b>BX6200, BX6400</b>



### Specifications

Model	EPRC-400P	RGB100
Continuous Regenerative Power	100 W (1/8 HP)	100 W (1/8 HP)
Resistance Value	400 Ω	150 Ω
Thermostat Operating Temperature	Open: 150 ± 7°C (302 ± 13°F) Close: 145 ± 12°C (293 ± 22°F) (Normally closed)	Open: 150 ± 7°C (302 ± 13°F) Close: 145 ± 12°C (293 ± 22°F) (Normally closed)
Thermostat Electrical Rating	120 VAC 4 A 30 VDC 4 A (Minimum current 5 mA)	120 VAC 4 A 30 VDC 4 A (Minimum current 5 mA)

● Install the regeneration unit in the place which has the same heat radiation capability as heat radiation plate

[Material: Aluminum 350 mm × 350 mm (13.8 in. × 13.8 in.), 3 mm (0.12 in.) thick].

### Dimensions Unit = mm (in.)

Mass: 250 g (8.8 oz.)

**DXF** C194

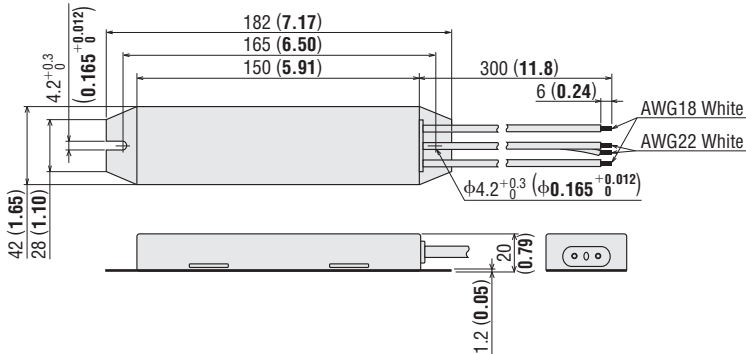

校正記号通りに修正してあります。  
モトイキでしたら修正いたします。

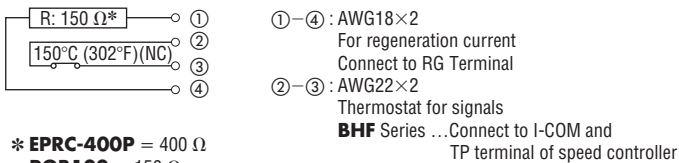

\* **EPRC-400P** = 400 Ω  
**RGB100** = 150 Ω

Introduction

BX

BLE

AC Input

BLE

BLU

Brushless Motors

BLH

DC Input

BLV

BHF

AC Speed Control Motors

FE100/  
FE200

ES01/  
ES02

US

Accessories

Installation

# Remote-Control Kit RoHS

The remote-control kit is useful if you want to detach the digital operator from the driver and install it on the frame of the equipment, etc., for remote operation.

The kit includes a connection cable for digital operator/driver connection [2 or 5 m (6.6 or 16.4 ft.)] and a rubber gasket.

## Product Line

Model	Length [m (ft.)]	Applicable Products
<b>BLFHS-02</b>	2 (6.6)	<b>BLF Series</b>
<b>BLFHS-05</b>	5 (16.4)	



Example of use



# Data Setting Software RoHS

In addition to setting and editing operating data and parameters, a computer can monitor the I/O and operating speed waveform.

●The settings and monitoring content differ depending on the applicable product.

## Product Line

Model	Applicable Products
<b>MEXE02</b>	<b>BLE Series</b>



## Connection between Computer and Driver

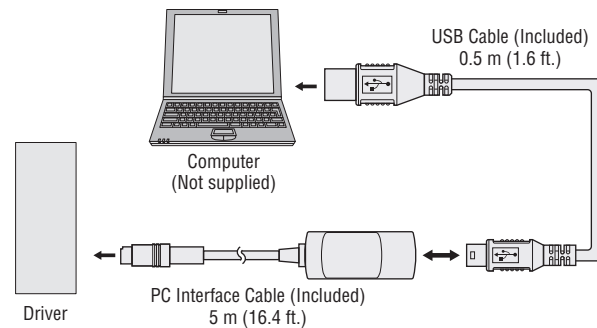

## Specifications (Operating Environment)

Operating Systems	The OS supports 32-bit (x86) and 64-bit (x64) versions only. Windows® 2000 Professional Service Pack 4 or later*1 Windows® XP Home Edition Service Pack 3 or later Windows® XP Professional Service Pack 2 Windows® XP Professional Service Pack 3*2 or later Windows® Vista Home Basic Service Pack 2 or later Windows® Vista Home Premium Service Pack 2 or later Windows® Vista Business Service Pack 2 or later Windows® Vista Ultimate Service Pack 2 or later Windows® Vista Enterprise Service Pack 2 or later Windows® 7 Starter Service Pack 1 or later Windows® 7 Home Premium Service Pack 1 or later Windows® 7 Professional Service Pack 1 or later Windows® 7 Ultimate Service Pack 1 or later Windows® 7 Enterprise Service Pack 1 or later
CPU*3	Intel Core Processor 2 GHz or more (The OS must be supported.)
Memory	32-bit (x86) version: 1 GB or more 64-bit (x64) version: 2 GB or more
Hard Disk*4	Available disk space of 30 MB or more
Disk Device	CD-ROM drive
Serial Interface	USB 1.1 1 port

\*1 Rollup 1 must be applied.

\*2 Service Pack 3 supports 32-bit (x86) version only.

\*3 The OS operating conditions must be satisfied.

\*4 Microsoft .NET Framework 2.0 Service Pack 2 is required to use **MEXE02**. If it is not already installed, it will be installed automatically, in which case up to 500 MB in additional space is required.

●Windows and Windows Vista are registered trademarks of Microsoft Corporation in the United States and other countries. Pentium is a registered trademark of Intel Corporation.

## Control Modules

### OPX-1A (RoHS)

#### Features

- Can be used as a monitor for speed, alarm codes and more.
- The speed can be set digitally.
- The speed control range and other characteristics are improved.
- More functions can be added including positioning operation and torque limiting.

#### Product Line

Model	Applicable Products
<b>OPX-1A</b>	<b>BX</b> Series

- With communication cable [2 m (6.6 ft.)]

#### Specifications

Display	LED
Cable Length	2 m (6.6 ft.)
Ambient Temperature	0~+50°C (+32~+122°F) (non-freezing)

#### Dimensions Unit = mm (in.)

##### ◇ Control Module

Mass: 0.07 kg (0.154 lb.)

**DXF** C142

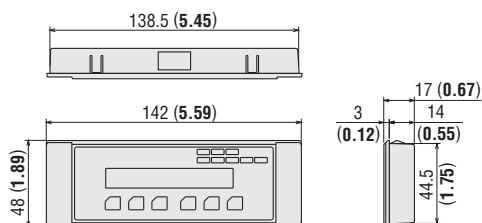

##### ◇ Panel Cut-Out

[Thickness of the mounting plate: 1 to 3 mm (0.04 to 0.12 in.)]

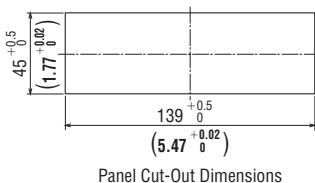

Panel Cut-Out Dimensions



### OPX-2A (RoHS)

#### Features

The driver internal parameter settings and data settings can be changed.  
May be used as a speed or I/O monitor.

- The settings and monitor content differ depending on the applicable product.

#### Product Line

Model	Applicable Products
<b>OPX-2A</b>	<b>BLE</b> Series <b>BLV</b> Series

#### Specifications

Display	LED
Cable Length	5 m (16.4 ft.)
Ambient Temperature	0~+40°C (+32~+104°F) (non-freezing)

#### Dimensions Unit = mm (in.)

##### ◇ Control Module

Mass: 0.25 kg (0.55 lb.)

**DXF** B453

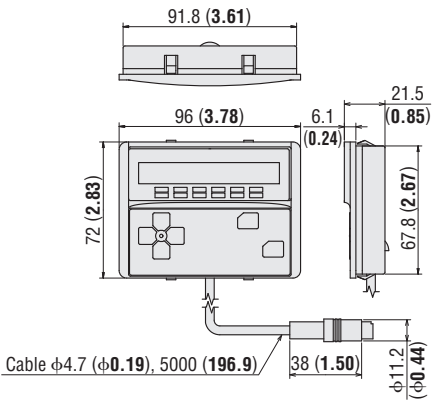

##### ◇ Panel Cut-Out

[Thickness of the mounting plate: 1 to 3 mm (0.04 to 0.12 in.)]

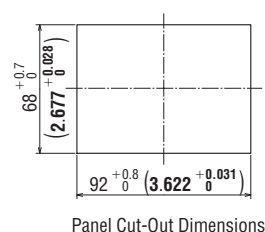

Panel Cut-Out Dimensions



Enlarged view

# Motor Speed Indicator

## SDM496 (RoHS)

This is the speed indicator for speed control motor models.

### Features

- The gear ratio is set with the digital switch of the body, and the output shaft speed of the motor and gearhead can be indicated digitally.
- If the surface installation socket (**EP11PF**, sold separately) is used, attachment to the DIN Rail is possible.
- This is not a standard certified product.



### Product Line

Model	Applicable Products
<b>SDM496</b>	<b>BLE</b> Series
	<b>BLU</b> Series
	<b>BLH</b> Series
	<b>ES01/ES02</b>
	<b>BHF</b> Series

The following items are included in each product.  
 Motor Speed Indicator, Adapter for Recessed Mounting,  
 Round Shape Socket, Unit Seal, Operating Manual

### Dimensions Unit = mm (in.)

Mass: 200 g (7.1 oz.) **DXF** A100

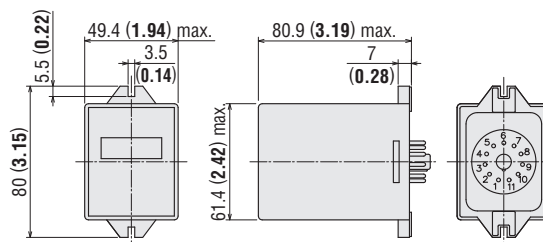

### Dimensions with Adapter Attached Unit = mm (in.)

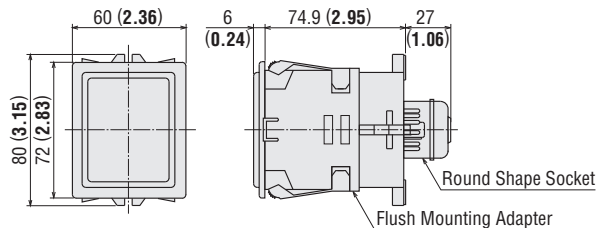

### Specifications

Power Supply Voltage (VAC)	Single-Phase 100~240
Permissible Voltage Range	-15~+10%
Rated Frequency (Hz)	50/60
Rated Input Current (A)	0.1
Display	Four Digits
Set Gear Ratio	96 Types
Ambient Temperature	0~+40°C (+32~+104°F)

### Panel Cut-Out

[Thickness of the mounting plate: 1 to 3.2 mm (0.04 to 0.13 in.)]

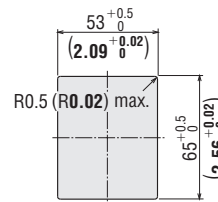

### Example of Connection

#### BLE Series

(30 pulses/rotation)

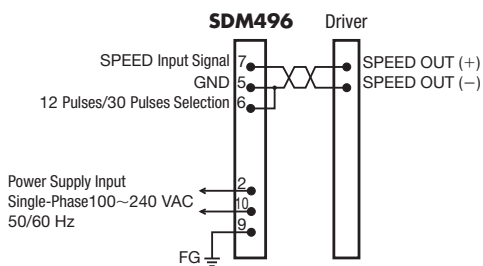

#### BLE Series - FBLII Compatibility Mode

(12 pulses/rotation)

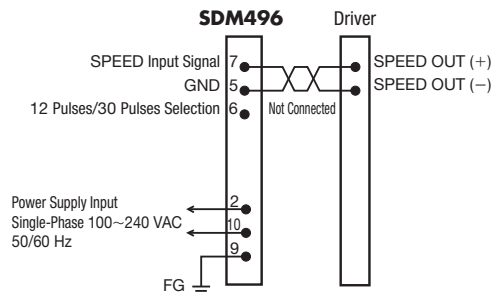



## ◇ BLU Series, BLH Series (30 pulses/rotation)

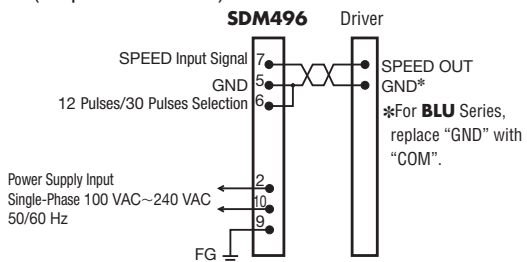

### Note

● The BLU series can use only sink logic. Source logic cannot be used.

## ◇ ES01/ES02

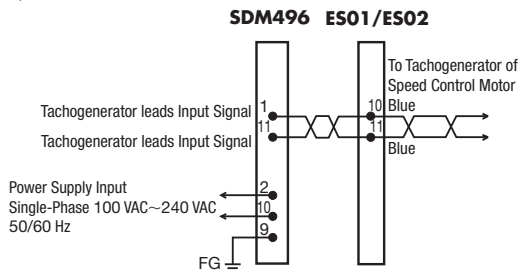

## ■ Flush Mounting Socket for Mounting DIN Rail (RoHS)

Use when installing the motor speed indicator on a DIN Rail.

### ● Product Line

Model	Applicable Products
EP11PF	Motor Speed Indicator <b>SDM496</b>

### ● Dimensions Unit = mm (in.)

Mass: 75 g (2.6 oz.)

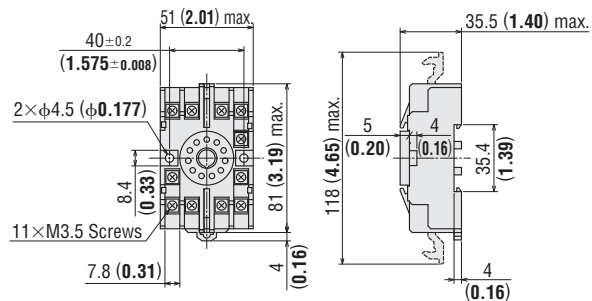

## ◇ BHF Series

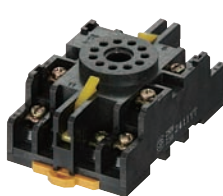
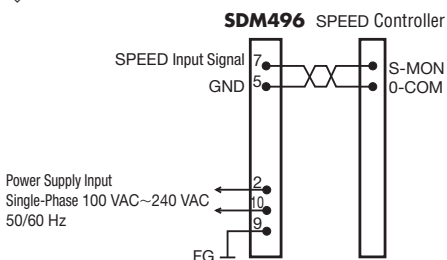

Example of use

# DIN Rail Mounting Plates

This is a DIN Rail installation plate for the driver and speed controller.

- Made of plastic, it is lightweight.
- DIN Rail attachment and removal are easy.

## PADP01 (RoHS)

### Product Line

Materials: Resin

Model	Applicable Products
<b>PADP01</b>	<b>BHF Series</b>

### Dimensions Unit = mm (in.)

Mass: 20 g (0.71 oz.)

DXF A1019

● Screws (Included)

M3 Length 8 mm (0.31 in.) ... 3 pieces

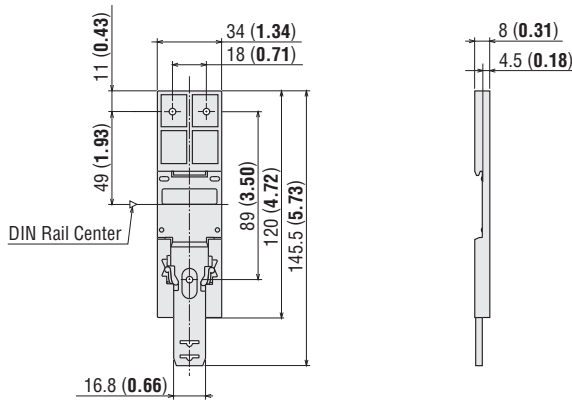

## PADP03 (RoHS)

### Product Line

Materials: Resin

Model	Applicable Products
<b>PADP03</b>	<b>BX Series</b> <b>BLE Series</b>

### Dimensions Unit = mm (in.)

Mass: 30 g (1.06 oz.)

DXF A1020

● Screws (Included)

M3 Length 8 mm (0.31 in.) ... 4 pieces

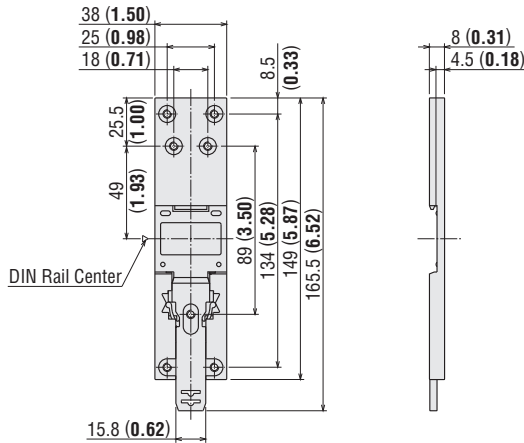

## Front Cover RoHS

A clear cover placed over the front panel of speed controller **FE100/FE200**.  
 This cover prevents accidental contact with the speed potentiometer and resulting shift in the set speed.  
 The front cover is not waterproof.

### Product Line

Model	Applicable Products
<b>PAFC01</b>	<b>FE100 FE200</b>



Example of use

### Dimensions Unit = mm (in.)

Mass: 10 g (0.35 oz.)

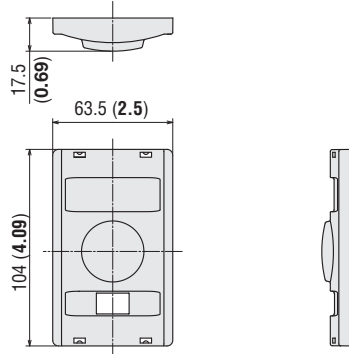

Introduction	
BX	
BLF	Brushless Motors
BLE	
BLU	
BLH	DC Input
BLV	
BHF	
FE100/ FE200	AC Speed Control Motors
ES01/ ES02	
US	
Accessories	
Installation	

## Motor/Gearhead Mounting Brackets RoHS

Dedicated mounting brackets for attaching and securing a motor and gearhead. They are a high-strength type, which can be used with high powered motors and gearheads. These brackets come with tapped holes. To mount the motor and gearhead, simply fasten with the screws provided to the gearhead. To mount the motor alone, mounting screws must be purchased separately.



### ■ Product Line

→ Page C-264

### ■ Dimensions

→ Page C-266

## Flexible Couplings RoHS

These products are clamp type couplings to connect a motor or gearhead shaft to the shaft of the equipment. Once the motor or gearhead is determined, the proper coupling can be selected.



### ■ Applicable Products

→ Page C-270

### ■ Specifications

→ Page C-271

### ■ Dimensions

→ Page C-272