

Speed Control Systems

Installation

Introduction

AC Input
BX

AC Input
BLF

AC Input
BLU

AC Input
FBLI

DC Input
BLH

BHF

FE100/
FE200

ES01/
ES02

US

Installation

Installation

Installation

Handling the Motor

Handling

Always carry the motor by placing it in the original package. If the motor must be carried by itself during testing or for assembly into equipment, take note of the following points:

- Hold the motor so that the output shaft points upward.
- Hold the motor not by its output shaft or motor cable, but by the motor body.

Storage

Temperature and humidity are important considerations since the storage condition has an influence on the life of motors.

Storage in places where there are large temperature and humidity variations will reduce the stator's insulation performance.

Moreover, leaving the motor for extended periods in places with high temperature and humidity, is likely to lead to grease deterioration inside the ball bearing and corrosion. When storing for long periods, it is recommended to coat the output shaft with an anti-corrosion agent, seal the motor in a polyethylene bag and store in a place with normal temperature and humidity.

Installation Conditions

Install the motor, gearhead and control circuit in a location that meets the following conditions. Use in a location that does not satisfy these conditions could damage the products.

- Indoors (This product is designed and manufactured to be installed within another device.)
- Ambient temperature: 0~+50°C (+32~+122°F) (non-freezing)
The ambient temperature range varies with each product. Refer to the pages where each product is listed.
- Ambient humidity: 85% or less (non-condensing)
- Not exposed to explosive, flammable or corrosive gases
- Not exposed to direct sunlight
- Not exposed to dust
- Not exposed to water, oil or other liquids
- A place where heat can escape easily
- Not exposed to continuous vibration or excessive impact
- Installation Category III, Pollution Degree 2, Class I Equipment
Only for the products that are certified by EN/IEC Standards and conform to EN/IEC Standards.
Installation Category II, Pollution Degree 3 for some products

Gearhead and Motor Installation

For connecting gearheads to motors and mounting motor to machinery, refer to page A-306.

Mounting Gearmotor to Machinery

The following figures show the mounting examples of the motor and gearhead onto machinery.

For Parallel Shaft Gearhead

Brushless Motor Systems and **BHF** Series parallel shaft type are combination type in which the motor and gearhead are pre-assembled. Mount to machinery using the "mounting screws" included.

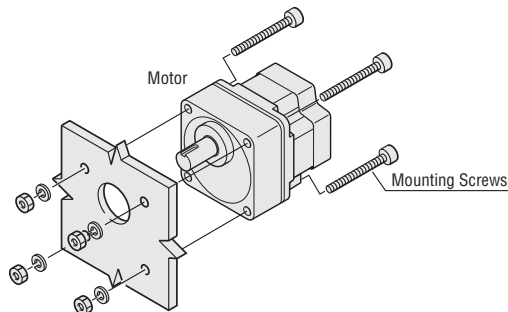

For GN Gearheads, 5GE□SA and 5GU□KA FE100/FE200, ES01/ES02 and US Series → Page A-307

For Geared Type

For mounting to machinery, obtain M4 mounting screws. The effective screw depth is 8 mm (0.31 in.).

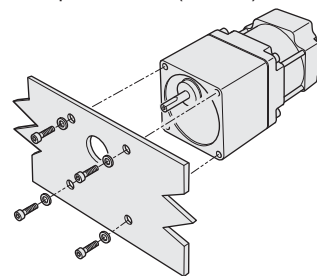

For Hollow Shaft Flat Gearhead

Installing from the Front Face

The output shaft pilot can be used to align the shaft.

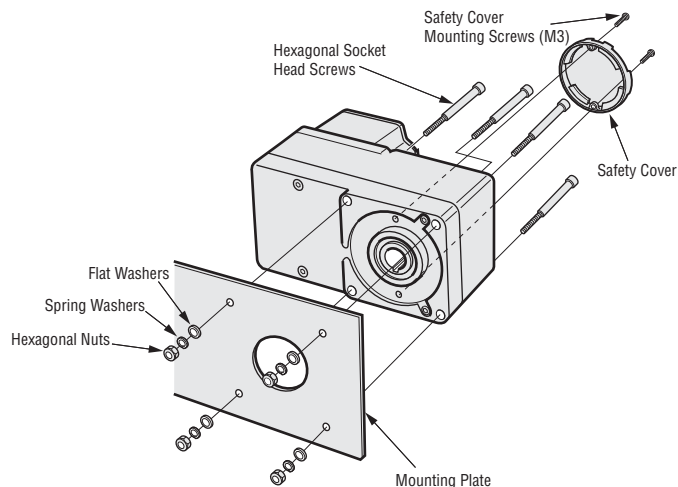

● Installing from the Rear Face

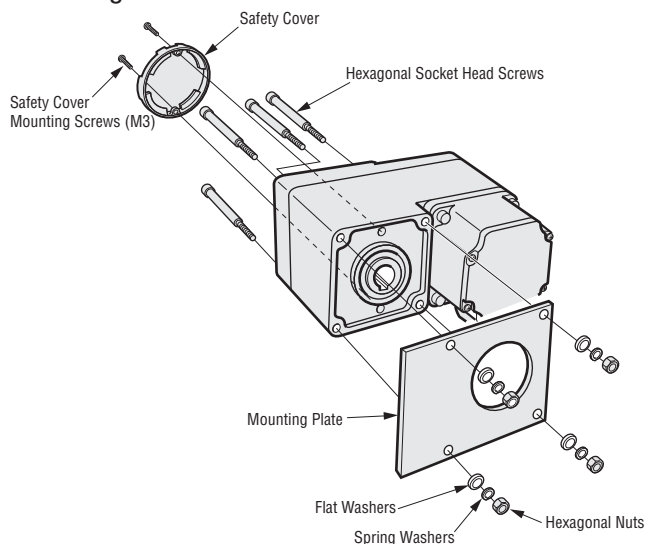

◇ For Right-Angle Gearheads

BHF Series right-shaft combination type → Page A-307

● Dimensions of Mounting Holes

◇ For Parallel Shaft Gearhead, Round Shaft Type

The dimension of the four motor mounting holes is shown as pitch diameter in the dimensions of each product.

The distance between the mounting holes is shown in the table below.

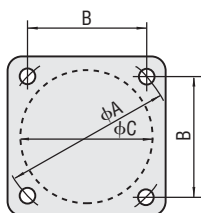

Motor Frame Size	A	B	C*1
□42 (□1.65)	48 (1.89) [43.8 (1.72)]*2	33.94 (1.336) [31 (1.220)]*2	37.6 (1.4803)
□60 (□2.36)	70 (2.76)	49.50 (1.949)	54 (2.1260)
□70 (□2.76)	82 (3.23)	57.98 (2.283)	64 (2.5197)
□80 (□3.15)	94 (3.70)	66.47 (2.617)	73 (2.8740)
□90 (□3.54)	104 (4.09)	73.54 (2.895)	83 (3.2677)
□104 (□4.09)	120 (4.72)	84.85 (3.341)	94 (3.7008)
□110 (□4.33)*3			

*1 "C" indicates the dimensions of flange pilot diameter of round shaft type.

*2 Figures in brackets [] indicate the dimensions for the geared type.

*3 The figure in brackets [] indicates the frame size for the gearhead.

◇ For Hollow Shaft Flat Gearhead

● Front Face

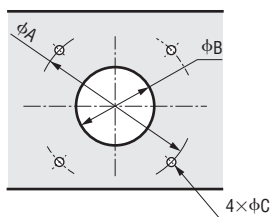

● Rear Face

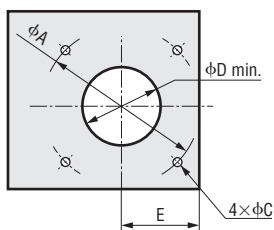

Mounting Hole Dimensions

Unit = mm (in.)

Gearhead Model	GFS2G□FR	GFS4G□FR	GFS5G□FR
Nominal Bolt Size	M5	M6	M8
φA	70 (2.76)	94 (3.70)	104 (4.09)
φB	34 ^{+0.039} ₀ (1.34 ^{+0.0015})	38 ^{+0.039} ₀ (1.50 ^{+0.0015})	50 ^{+0.039} ₀ (1.97 ^{+0.0015})
φC	5.5 (0.217)	6.5 (0.256)	8.5 (0.335)
φD	25 (0.98)	30 (1.18)	35 (1.38)
E	29 (1.14)	39 (1.54)	44 (1.73)

● Enter the gear ratio in the box (□) within the model name.

Note:

● When installing the hollow shaft flat gearhead from the rear face, provide dimension "E" to prevent the mounting plate from contacting the motor.

● Mounting the Load

◇ For Parallel Shaft Gearhead, Round Shaft Gearhead

→ Page A-308

◇ For Hollow Shaft Flat Gearhead

- Install the load shaft to the hollow output shaft by aligning the center of the hollow shaft with that of the load shaft.
- The hollow output shaft has a key slot. Machine a matching key slot on the load shaft and use the supplied key to affix the two shafts across the slots.
- If the motor is intended to receive large impacts due to frequent instantaneous stops or carry a large overhung load, use a stepped load shaft.

Notes:

- When installing the load shaft to the hollow output shaft, be careful not to damage the hollow output shaft or bearing.
- To prevent seizure, apply a coat of molybdenum disulfide grease on the exterior surface of the load shaft and interior surface of the hollow output shaft.
- Do not attempt to modify or machine the hollow output shaft. Doing so may damage the bearing and cause the hollow shaft flat gearhead to break.

● Stepped Load Shaft

Install a hexagonal socket head screw over a stopper ring, spacer, flat washer and spring washer, and tighten the screw to affix the load shaft.

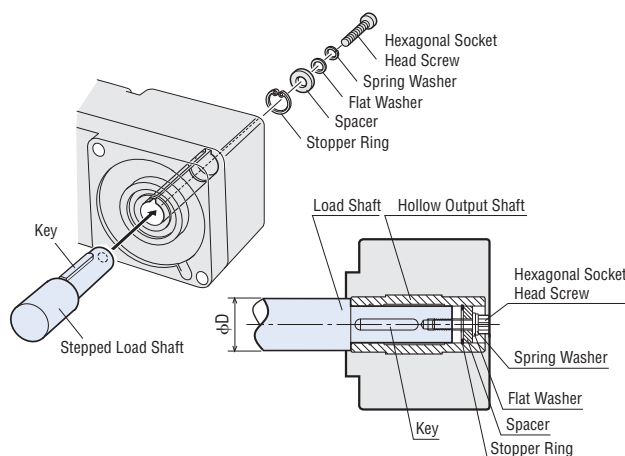

• Straight Load Shaft

Install a hexagonal socket head screw over a stopper ring, spacer, flat washer and spring washer, with a spacer also inserted underneath the load shaft, and tighten the screw to affix the load shaft.

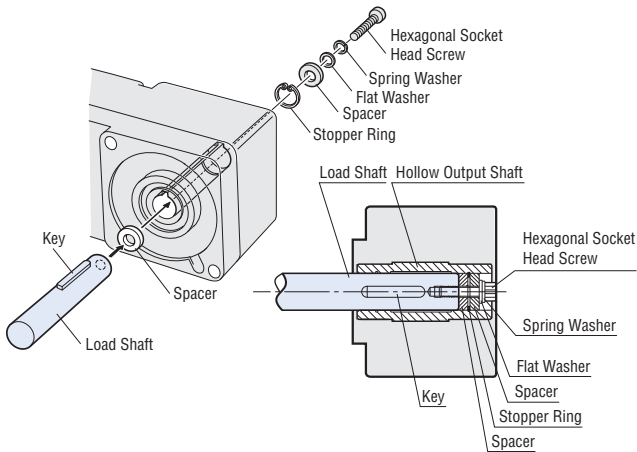

Recommended Load Shaft Installation Dimensions

Unit = mm (in.)

Gearhead Model	GFS2G□FR	GFS4G□FR	GFS5G□FR
Inner Diameter of Hollow Shaft	$\phi 12^{+0.027}_{-0.018}$ ($\phi 0.4724^{+0.0011}_{-0.0007}$)	$\phi 15^{+0.027}_{-0.018}$ ($\phi 0.5906^{+0.0011}_{-0.0007}$)	$\phi 20^{+0.033}_{-0.021}$ ($\phi 0.7874^{+0.0013}_{-0.0008}$)
Recommended Tolerance of Load Shaft	$\phi 12^{0}_{-0.018}$ ($\phi 0.4724^{0}_{-0.0007}$)	$\phi 15^{0}_{-0.018}$ ($\phi 0.5906^{0}_{-0.0007}$)	$\phi 20^{0}_{-0.021}$ ($\phi 0.7874^{0}_{-0.0008}$)
Nominal Diameter of Stopper Ring	$\phi 12$ ($\phi 0.47$), C-shaped	$\phi 15$ ($\phi 0.59$), C-shaped	$\phi 20$ ($\phi 0.79$), C-shaped
Applicable Screw	M4	M5	M6
Spacer Thickness*	3 (0.12)	4 (0.16)	5 (0.20)
Outer Diameter of Step Part ϕD	20 (0.79)	25 (0.98)	30 (1.18)

* Determine the spacer thickness in conformance with the table. If the spacer is thicker than the specified dimension, the screw will project from the surface and interfere with the safety cover.

- Enter the gear ratio in the box (□) within the model name.
- Screws or other parts used to install the load shaft are not included. They must be purchased separately.

◇ For Right-Angle Gearheads

BHF Series right-shaft combination type → Page A-309

● Dimensions for Mounting Screws

◇ Parallel Shaft Gearhead

BX, BLF, BLU, FBLII and **BLH** Series

The screw shown below is included with the motor.

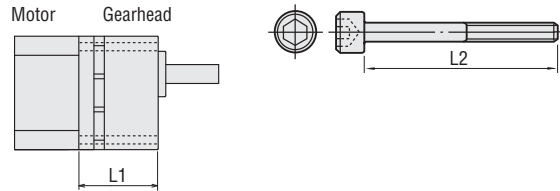

Gearhead Model	Gearhead		Mounting Screw	
	L1 [mm (in.)]	L2 [mm (in.)]	Screw Size	
GFS2G5~20	42 (1.65)	50 (1.97)	M4 P0.7	
GFS2G30~100	46 (1.81)	55 (2.17)		
GFS2G200	51 (2.01)	60 (2.36)		
GFS4G5~20	49 (1.93)	65 (2.56)	M6 P1.0	
GFS4G30~100	54 (2.13)	70 (2.76)		
GFS4G200	59 (2.32)	75 (2.95)		
GFS5G5~20	55 (2.17)	75 (2.95)	M8 P1.25	
GFS5G30~100	68 (2.68)	90 (3.54)		
GFS5G200	74 (2.91)	95 (3.74)		
GFS6G5~20	70 (2.76)	95 (3.74)		
GFS6G30, 50	82 (3.23)	110 (4.33)		
GFS6G100, 200	96 (3.78)	120 (4.72)		
GFB5G5~20	55 (2.17)	75 (2.95)		
GFB5G30~100	68 (2.68)	90 (3.54)		
GFB5G200	74 (2.91)	95 (3.74)		

● Mounting screws: 4 flat washers, spring washers and hexagonal nuts are included.

◇ Hollow Shaft Flat Gearhead

BX, BLF, BLU, and **BLH** Series

The screw shown below is included with the motor.

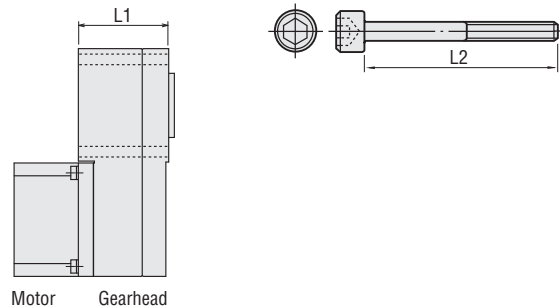

Gearhead Model	Gearhead		Mounting Screw	
	L1 [mm (in.)]	L2 [mm (in.)]	Screw Size	
GFS2G5~200FR	47.8 (1.88)	65 (2.56)	M5 P0.8	
GFS4G5~200FR	53.2 (2.09)	70 (2.76)	M6 P1.0	
GFS5G5~200FR	65.2 (2.57)	90 (3.54)	M8 P1.25	

● Mounting screws: 4 flat washers, spring washers and hexagonal nuts are included.

◇ For **BHF** Series → Page A-310

◇ For **GN** Gearheads, **GE** Gearheads, **GU** Gearheads and Right-Angle Gearheads → Page A-310

◇ For **V** Series → Page A-310

Control Circuit Installation

Mounting Method of Control Circuit

The following figures show the mounting examples of control circuit, such as driver, speed controller and control unit inside a machinery. Mounting screws to machinery are not included. They must be purchased separately.

Note:

- When mounting the control circuits in an enclosed space such as a control box or somewhere close to a heat-radiating object, vent holes should be used to prevent the control circuit from overheating. If the ambient temperature listed in the installation conditions for the control circuit is exceeded, use forced air cooling with a fan.

Mounting with Mounting Brackets

Use the mounting holes of the control circuit with four screws (M4: not included) that there is no gap between them and the metal plate.

Back Mounting

Applicable Products:

- BX** Series
- FBLI** Series
- BHF** Series

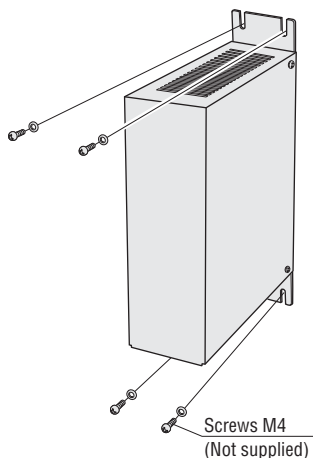

Base Mounting

Applicable Products:

- FBLI** Series

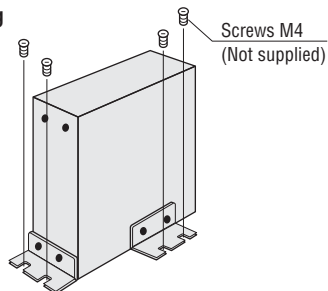

Notes:

- The mounting holes (M3-4 places) on the back of a control circuit must only be used for installation.
- Use the mounting screws included when installing the mounting bracket to the control circuit.
- To improve ventilation, mount the control circuit in an upright position as shown in the figure.

Mounting to DIN Rail

Attach the accessory DIN rail mounting plate (**PADP01**) to the back of the control circuit using the screws supplied with the plate.

Hang the control circuit onto a DIN rail (①), and fix the bottom onto the rail (②).

Applicable Products:

- BX** Series
- FBLI** Series
- BHF** Series
- ES01/ES02**

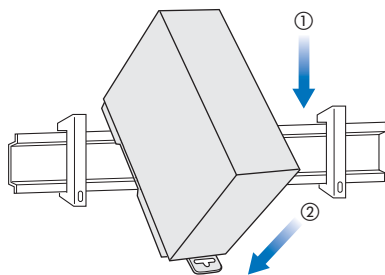

Notes:

- The mounting holes (M3-3 places) on the back of a control circuit must only be used for installing a DIN Rail Mounting Plate.
- Use the mounting screws included when installing the DIN Rail Mounting Plate to the control circuit.

DIN rail mounting plate **PADP01** → Page A-301

Mounting with Mounting Screws

To fasten the driver with screws, use the two screw holes. For mounting to machinery, obtain M4 mounting screws. They must be purchased separately.

Box Type

Applicable Product:

- BLF** Series

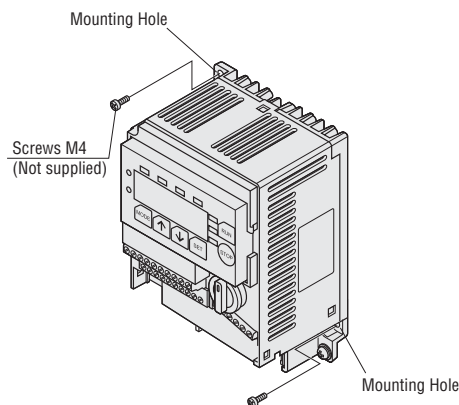

Board Type

For mounting to machinery, obtain M3 mounting screws.

Applicable Product:

- BLH** Series

Using Mounting Holes on Circuit Board

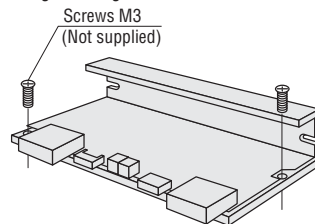

Using Mounting Holes at the Back

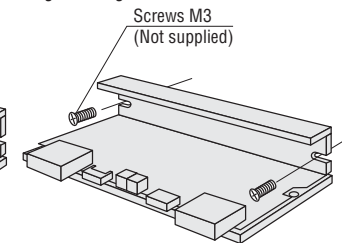

Panel-Installation Type

Use the mounting holes of the speed controller to secure the control circuit with two screws and nuts so that there is no gap between them and the metal plate.

Applicable Products:

- BLU** Series
- FE100/FE200**
- US** Series

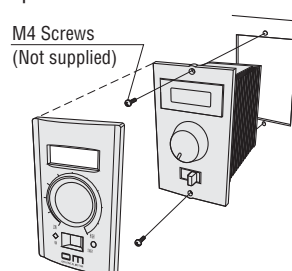

● **Mounting Method of Two or More Control Circuits**

When mounting two or more control circuits, separate them by a space of at least 20 mm (0.79 in.) and 25 mm (0.98 in.) in the horizontal and vertical directions, because the ambient temperature rises due to the temperature rise of the control circuit itself. Also, leave at least 25 mm (0.98 in.) of space between the control circuit and other devices or structures.

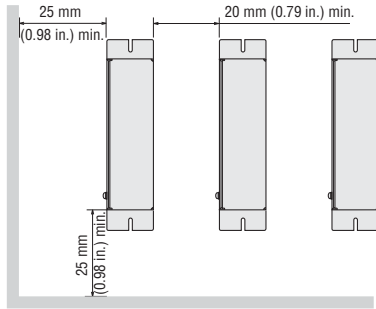

Make sure not to cover the heat sink and heat radiation vents on the side and bottom of the driver. The ambient temperature will vary depending on the specific installation conditions within the equipment. Make sure the ambient operating temperature determined by the installation conditions will not be exceeded.

◇ **For BLF Series**

When mounting the driver inside an enclosure, separate the driver from other equipment by a space of at least 25 mm (0.98 in.) and 100 mm (3.94 in.) in the horizontal and vertical directions. When mounting two or more drivers, separate them by a space of at least 20 mm (0.79 in.) and 100 mm (3.94 in.) in the horizontal and vertical directions.

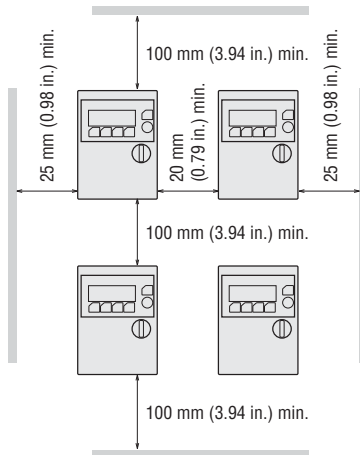

◇ **For BLU Series**

When mounting the driver inside an enclosure, mount it so that one of the two driver heat radiation vents faces downward.

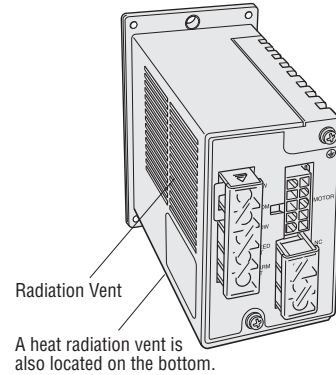

When mounting two or more drivers, separate them by a space of at least 25 mm (0.98 in.) and 50 mm (1.97 in.) in the horizontal and vertical directions.

◇ **For BLH Series**

When mounting two or more drivers, separate them by a space of at least 20 mm (0.79 in.) and 50 mm (1.97 in.) in the horizontal and vertical directions.

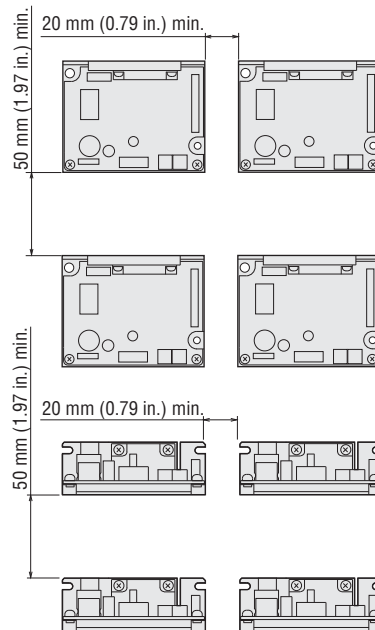

◇ **For FE100/FE200**

When mounting the FE100/FE200 inside an enclosure, separate them by a space of at least 30 mm (1.18 in.) and 100 mm (3.94 in.) in the horizontal and vertical directions.

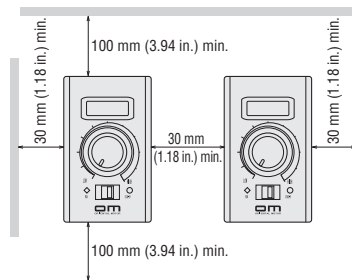

Introduction

AC Input
BX

AC Input
BLF

AC Input
BLU

AC Input
FBLI

DC Input
BLH

BHF

FE100/
FE200

ES01/
ES02

US

Installation