

Hollow Rotary Actuators

DGII Series

Horizontal Mounting

α STEP AZ Series Equipped

The **DG II** Series combines a hollow rotary table with a controller to create an integrated product that can be directly mounted to large inertia tables or arms. Time and cost associated with mechanism design, parts selection and assembly adjustment can be reduced. No sensor required with **AZ** Series technology.

EtherCAT
EtherNet/IP



AC Input DC Input



Horizontal Mounting Type

Simplified Design and Programming

- Houses Entire Rotary Motion**

Number of components can be reduced

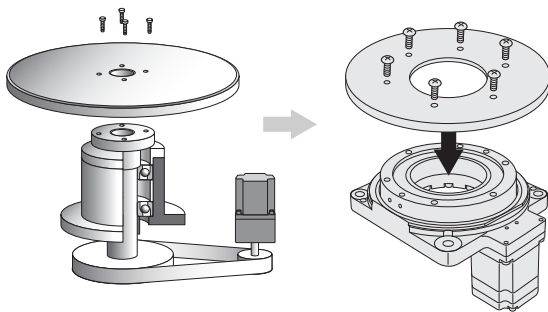

Motor + Mechanical Component
(Designed and arranged separately)

DGII Series
(Vertical mount type shown)

- Simple Control by Setting No-Entry Zones**

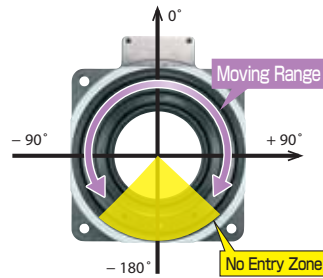

If there are obstructions on the equipment, it is possible to set a region on the output table that will be avoided.

- Reduce Time with Short-Cut Operations**

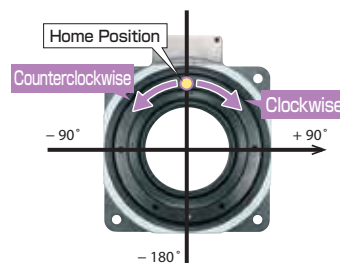

Example:
When moving from the 0° position to 270° position, counterclockwise movement is automatically selected as the shortest rotation direction.

- High Positioning Accuracy**

	Motor Vertical Mounting	Motor Horizontal Mounting
Backlash	Non-Backlash	6 arc minutes (0.1°)
Repetitive Positioning Accuracy	±15 arc seconds (±0.004°)	±30 arc seconds (±0.008°)

Applications Requiring High Performance and High Rigidity

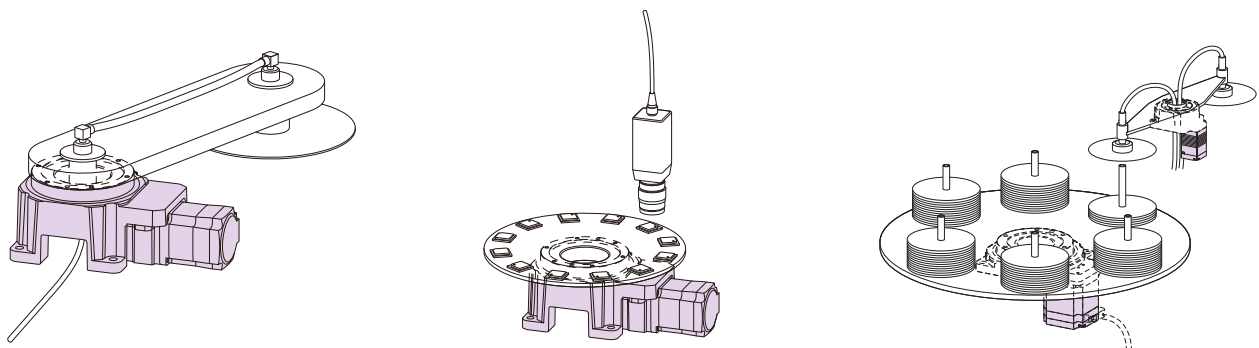

Visit www.orientalmotor.com

For further information (specifications, dimensions, speed-torque characteristics)

Product Line

Vertical Mount Type

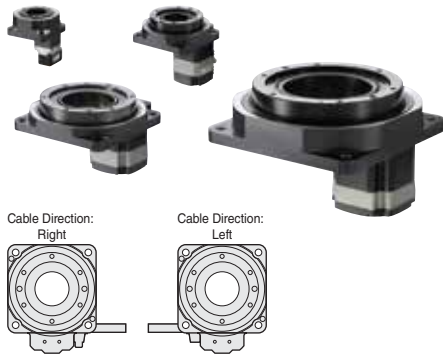

Power Supply	Hollow Rotor Actuator				Driver Type
	Frame Size				
	60 mm	85 mm	130 mm	200 mm	
AC Input	—	•	•	•	Built-in Controller RS-485 Communication Pulse Input Pulse Input Network Compatible Driver*1 Network Compatible Multi-Axis Driver*2 EtherCAT EtherNet/IP
DC Input	•	•	•	—	

Horizontal Mount Type

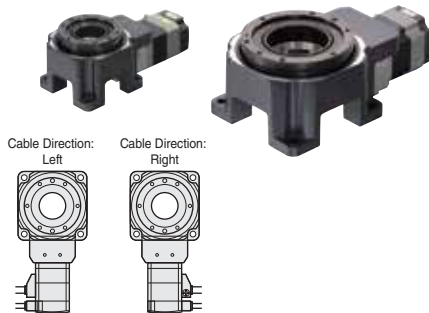

Power Supply	Hollow Rotor Actuator			Driver Type
	Gear Ratio	Frame Size		
		85 mm	130 mm	
AC Input	12	•	—	Built-in Controller RS-485 Communication Pulse Input Pulse Input Network Compatible Driver*1 Network Compatible Multi-Axis Driver*2 EtherCAT EtherNet/IP
	18	•	•	
	36	•	•	
DC Input	12	•	—	
	18	•	•	
	36	•	•	

*1 AC input only
*2 DC input only

System Configuration

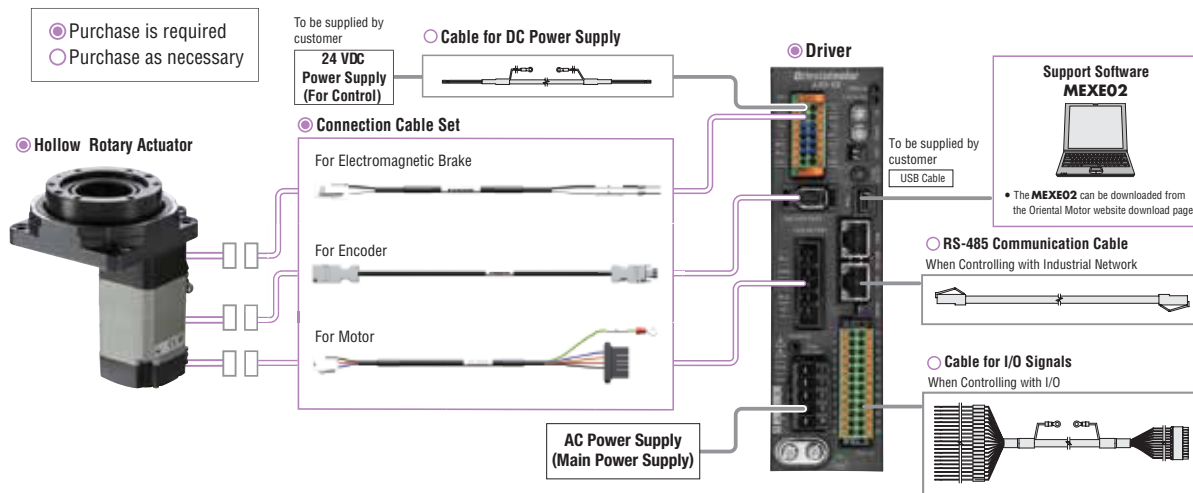

DGII Series		
Hollow Rotary Acuator	Driver	Connection Cable
DGB85R12-AZAKR	AZD-KEP	CC010VZF2
\$1,95500	\$506.00	\$35.00

+

Accessory
I/O Signal Cable
CC16D010B-1
\$25.00

ORIENTAL MOTOR U.S.A. CORP.

Technical Support Tel: 800-468-3982 7:30A.M. - 7:00P.M. C.S.T (M-F) E-mail: techsupport@orientalmotor.com

- 1,500 Products Next Day Shipping
- Free Sizing

- Over 10,000 Products Shipped within 7~9 Business Days
- Global Support