

MB Series

AC Centrifugal Blowers

Impeller Diameter

ϕ6.30 in. (ϕ160 mm)



Ambient Temperature: 14°F to 122°F (-10°C to +50°C)
Operating Voltage Range: ±10%

Materials

Motor Case: Die Cast Aluminum
Casing: Die Cast Aluminum
Impeller: Aluminum
Overheat Protection: Built-in Thermal Protector
Bearings: Ball Bearings

Specifications



Model	Voltage VAC	Frequency Hz	Current A	Input Power W	Speed r/min	Max. Air Flow		Max. Static Pressure		Noise Level dB (A)	Capacitor μF
						CFM	m ³ /min	inH ₂ O	Pa		
MB1665-B	Single-Phase 100	50	2.6	260	2750	282	8.0	1.96	490	76	40
	Single-Phase 100	60	3.7	360	3100	318	9.0	2.75	686	80	
	Single-Phase 110	60	3.7	380	3200	318	9.0	2.75	686	80	
	Single-Phase 115	60	3.7	400	3200	318	9.0	2.75	686	80	
MB1665-D	Single-Phase 200	50	1.3	245	2700	272	7.7	1.96	490	75	8.0
	Single-Phase 200	60	1.8	340	3000	297	8.4	2.75	686	76	
	Single-Phase 220	60	1.8	360	3150	307	8.7	2.75	686	77	
	Single-Phase 230	50	1.3	270	2750	282	8.0	1.96	490	75	
	Single-Phase 230	60	1.8	370	3150	314	8.9	2.75	686	77	
MB1665-T	Three-Phase 200	50	1.8	280	2750	282	8.0	1.96	490	76	—
	Three-Phase 200	60	1.8	360	3100	318	9.0	2.75	686	80	
	Three-Phase 230	60	1.8	400	3200	318	9.0	2.75	686	80	

•How to read the specifications→Page E-13 •Details of safety standards→Page G-2

Air Flow — Static Pressure Characteristics

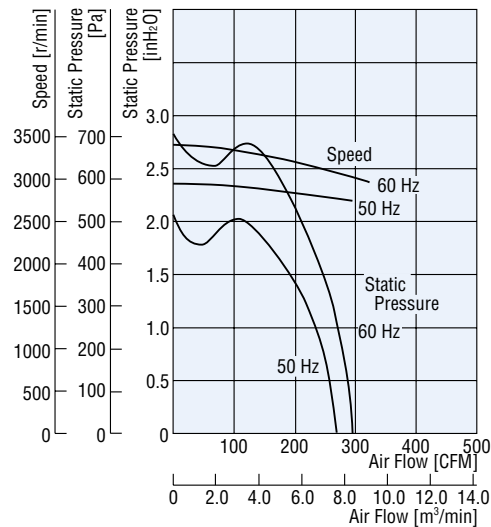

Frequency — Audible Noise Level (dB)

Measured at a distance of 3.3 feet (1 m) from the fan intake side

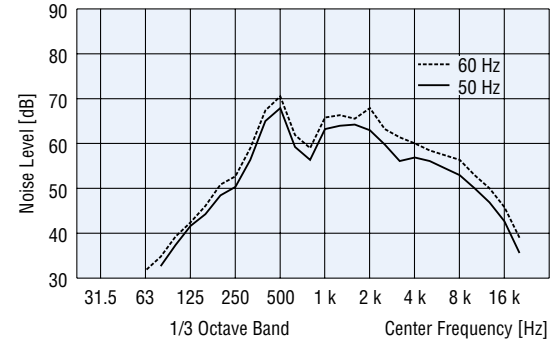

Dimensions

Scale 1/4, Unit = inch (mm)

Weight: 11 lb. (5 kg)

DXF E059

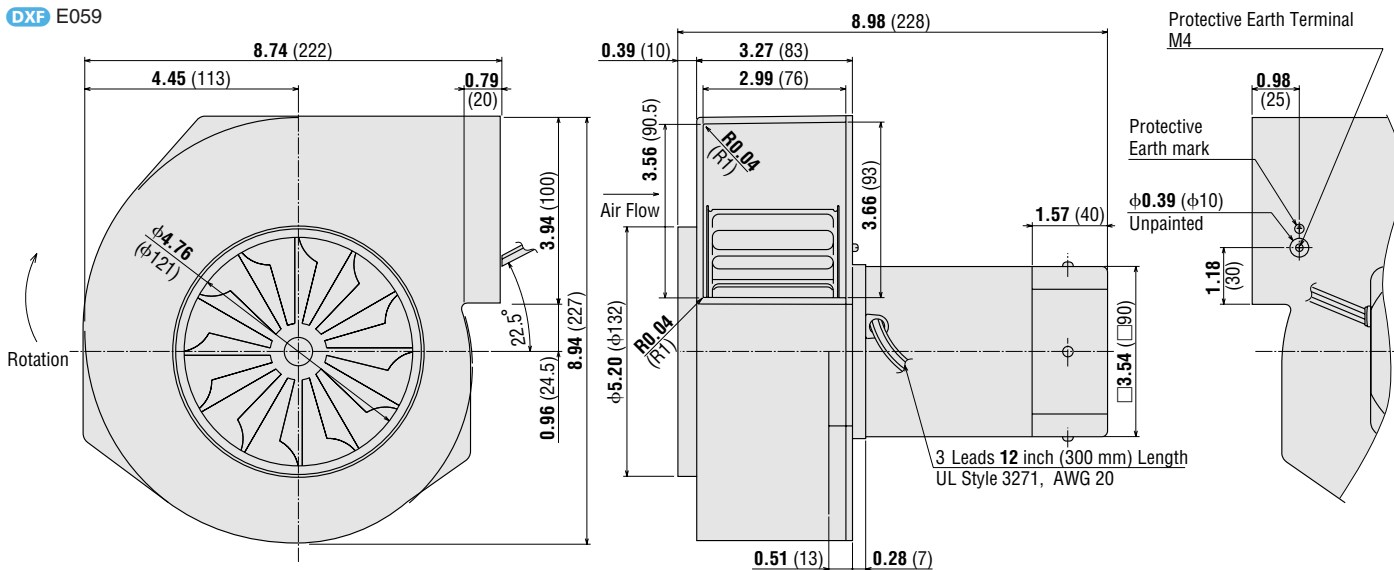

Panel Cut-Out

Scale 1/4, Unit = inch (mm)

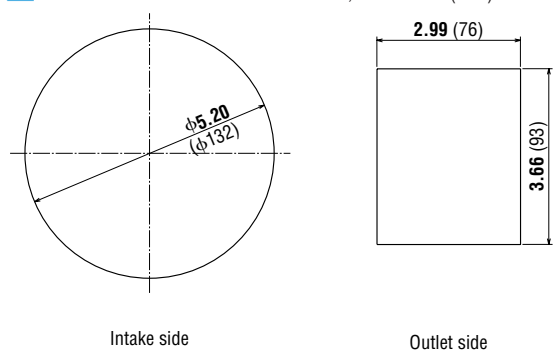

Connection Diagrams

● MB1665-B, D

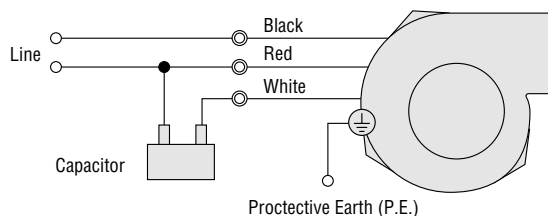

● How to connect a capacitor → Page E-113

● MB1665-T

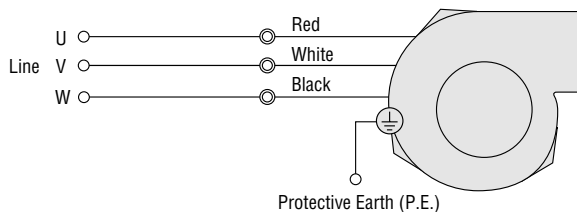

Thermostats (Sold Separately)

Thermostats make it possible for fans to operate only when cooling is necessary, thereby conserving energy.



Thermostats: **AM1-WA1**
AM1-XA1

→ Page E-97

● Capacitor (Capacitor and capacitor cap are provided with single-phase blowers.)

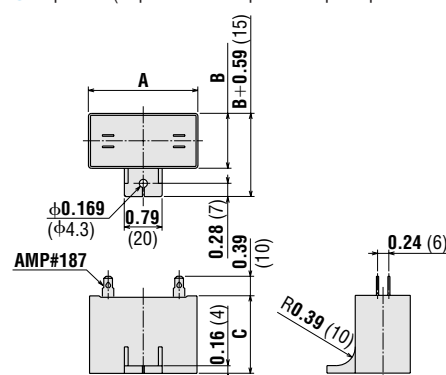

Model	Capacitor	Dimensions inch (mm)			Weight oz. (g)
		A	B	C	
MB1665-B	CH400CFAUL	2.28 (58)	1.61 (41)	2.28 (58)	6.7 (190)
MB1665-D	CH80BFAUL	2.28 (58)	1.38 (35)	1.97 (50)	5.3 (150)

Accessories (Sold Separately)

Item	Model	Safety Standards	Page
Mounting Bracket	PAS5A	—	E-109

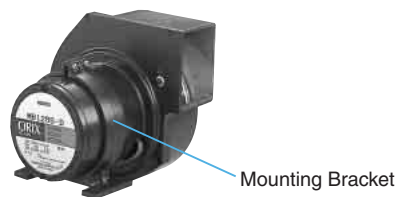

Introduction

MRS

Variable Flow

MU

Long Life

MDS · MD

MB

MBD

MF

MFD

Thermostats

Accessories

Before Using

a Fan

MB Series

AC Centrifugal Blowers

Impeller Diameter

ϕ4.72 in. (ϕ120 mm)



Ambient Temperature: 14°F to 122°F (−10°C to +50°C)
Operating Voltage Range: ±10%

Materials

Motor Case: Die Cast Aluminum
Casing: Die Cast Aluminum
Impeller: Aluminum
Overheat Protection: Built-in Thermal Protector
Bearings: Ball Bearings

Specifications



Model	Voltage VAC	Frequency Hz	Current A	Input Power W	Speed r/min	Max. Air Flow		Max. Static Pressure		Noise Level dB (A)	Capacitor μF
						CFM	m ³ /min	inH ₂ O	Pa		
MB1255-B	Single-Phase 100	50	1.3	110	2850	155	4.4	1.24	309	67	10
	Single-Phase 100	60	1.6	150	3300	180	5.1	1.77	441	71	
	Single-Phase 110	60	1.6	150	3300	180	5.1	1.77	441	71	
	Single-Phase 115	60	1.6	150	3300	180	5.1	1.77	441	72	
MB1255-D	Single-Phase 200	50	0.6	110	2850	155	4.4	1.26	314	67	2.0
	Single-Phase 200	60	0.8	145	3200	173	4.9	1.81	451	69	
	Single-Phase 220	60	0.8	145	3300	180	5.1	1.81	451	71	
	Single-Phase 230	50	0.6	110	2900	159	4.5	1.26	314	67	
	Single-Phase 230	60	0.8	150	3300	184	5.2	1.81	451	71	
MB1255-T	Three-Phase 200	50	0.6	85	2850	155	4.4	1.26	314	67	—
	Three-Phase 200	60	0.6	120	3280	177	5.0	1.81	451	70	
	Three-Phase 220	60	0.65	125	3300	180	5.1	1.81	451	71	
	Three-Phase 230	60	0.65	130	3300	184	5.2	1.81	451	71	

•How to read the specifications →Page E-13 •Details of safety standards →Page G-2

Air Flow — Static Pressure Characteristics

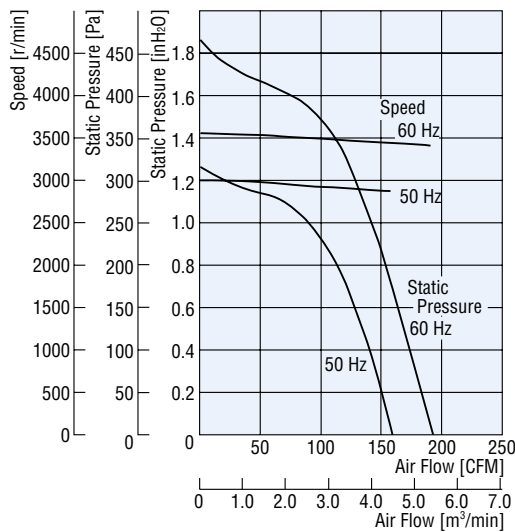

Frequency — Audible Noise Level (dB)

Measured at a distance of 3.3 feet (1 m) from the fan intake side

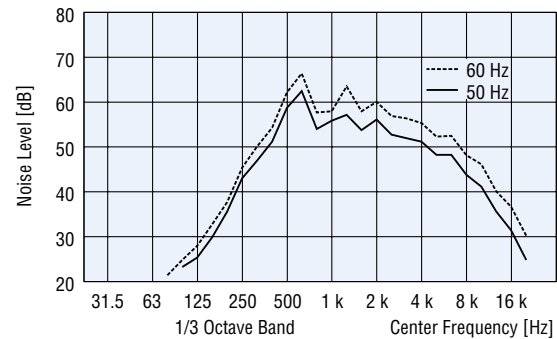

Dimensions Scale 1/4, Unit = inch (mm)

Weight: 8.8 lb. (4 kg)

DXF E060

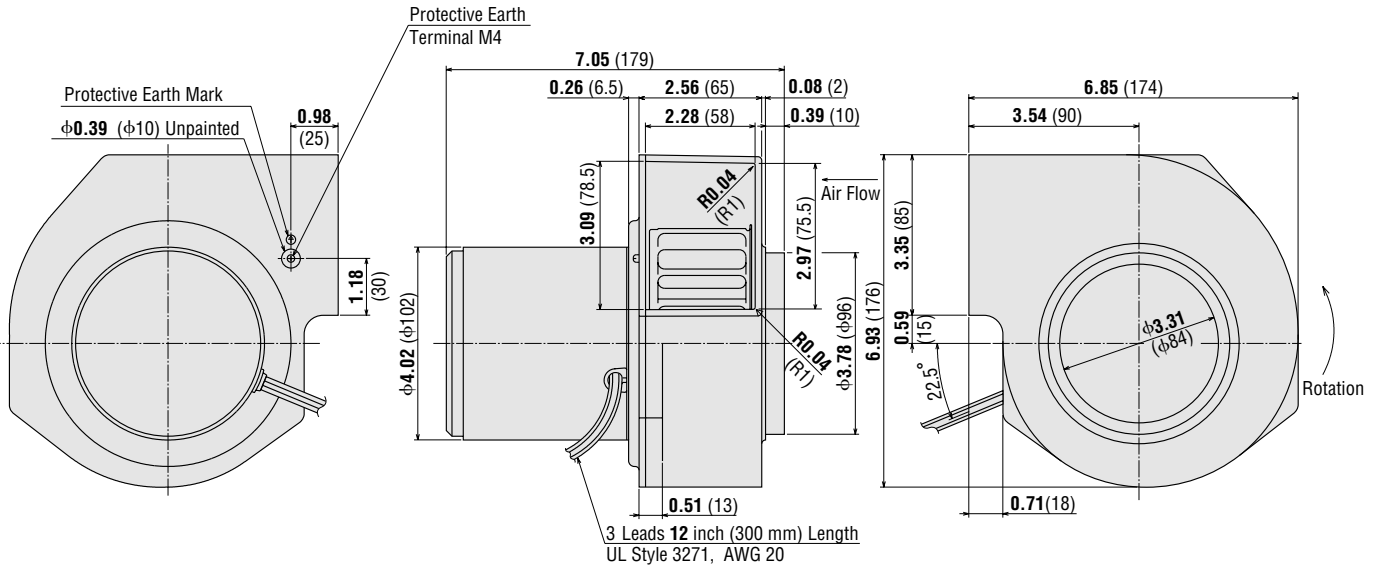

Panel Cut-Out Scale 1/4, Unit = inch (mm)

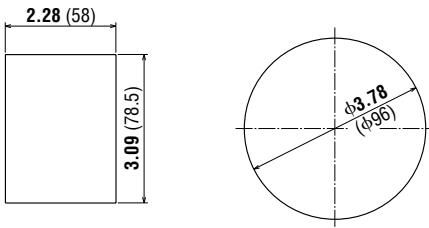

Outlet side

Intake side

Connection Diagrams

● MB1255-B, D Type

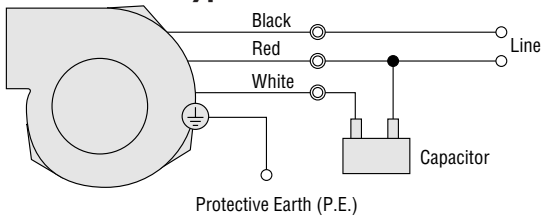

● How to connect a capacitor → Page E-113

● MB1255-T Type

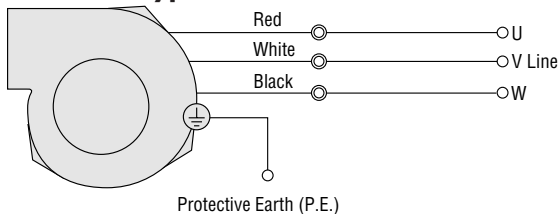

● Capacitor (Capacitor and capacitor cap are provided with single-phase blowers.)

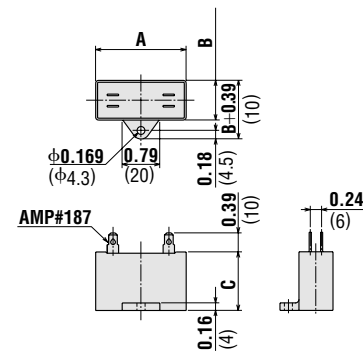

Model	Capacitor	Dimensions <small>inch (mm)</small>			Weight oz. (g)
		A	B	C	
MB1255-B	CH100CAUL	1.89 (48)	0.89 (22.5)	1.24 (31.5)	1.41 (40)
MB1255-D	CH20BFAUL	1.89 (48)	0.75 (19)	1.14 (29)	1.41 (40)

Accessories (Sold Separately)

Item	Model	Safety Standards	Page
Finger Guard	FGB12	*	E-104
Filter	FLB12	—	E-106
Mounting Bracket	PAS6A	—	E-109
Duct Joint	FD12	—	E-110

* These products have been designed to pass tests set forth under the UL and CSA standards for equipment used in fans. They conform to the standards only when used with an **ORIX FAN**.

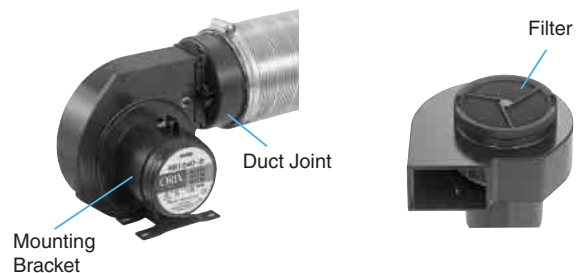

● A finger guard can be installed in place of the filter.

Thermostats (Sold Separately)

Thermostats make it possible for fans to operate only when cooling is necessary, thereby conserving energy.



Thermostats: **AM1-WA1**
AM1-XA1

→ Page E-97

Introduction

MRS

Variable Flow

MU

Long Life

MDS · MD

MB

MBD

MF

MFD

Thermostats

Accessories

Before Using a Fan

Centrifugal Blowers

DC Input

AC Input

DC Input

AC Input

DC Input

DC Input

DC Input

DC Input

DC Input

DC Input

DC Input

MB Series

AC Centrifugal Blowers

Impeller Diameter

ϕ3.94 in. (ϕ100 mm)



Ambient Temperature: 14°F to 122°F (−10°C to +50°C)
Operating Voltage Range: ±10%

Materials

Motor Case: Die Cast Aluminum
Casing: Die Cast Aluminum
Impeller: Aluminum
Overheat Protection: Built-in Thermal Protector
Bearings: Ball Bearings

Specifications



Model	Voltage VAC	Frequency Hz	Current A	Input Power W	Speed r/min	Max. Air Flow		Max. Static Pressure		Noise Level dB(A)	Capacitor μF
						CFM	m ³ /min	inH ₂ O	Pa		
MB 1040-B	Single-Phase 100	50	0.50	45	2750	81.2	2.3	0.826	206	60	3.0
	Single-Phase 100	60	0.55	55	3050	91.8	2.6	1.14	284	63	
	Single-Phase 110	60	0.55	55	3200	91.8	2.6	1.14	284	64	
	Single-Phase 115	60	0.55	55	3200	91.8	2.6	1.14	284	64	
MB 1040-D	Single-Phase 200	50	0.25	40	2750	81.2	2.3	0.826	206	61	1.2
	Single-Phase 200	60	0.30	50	3100	91.8	2.6	1.22	304	64	
	Single-Phase 220	60	0.30	55	3200	95.3	2.7	1.22	304	65	
	Single-Phase 230	50	0.30	50	2750	84.7	2.4	0.826	206	61	
	Single-Phase 230	60	0.30	55	3250	95.3	2.7	1.22	304	65	

•How to read the specifications →Page E-13 •Details of safety standards →Page G-2

Air Flow — Static Pressure Characteristics

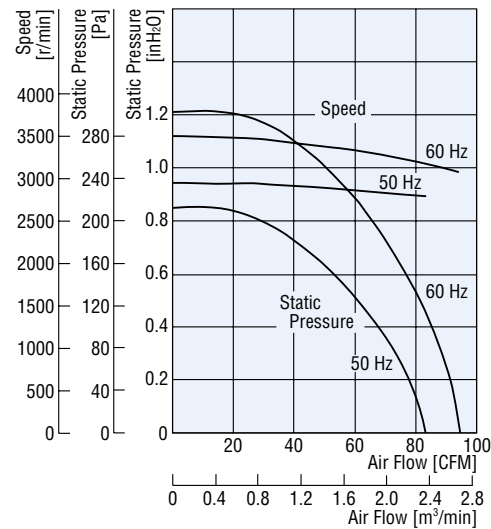

Frequency — Audible Noise Level (dB)

Measured at a distance of 3.3 feet (1 m) from the fan intake side

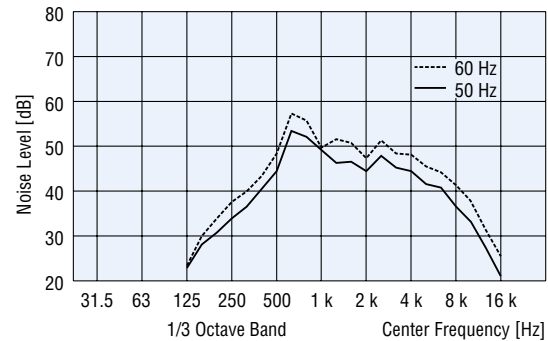

■ Dimensions Scale 1/4, Unit = inch (mm)

Weight: 4.4 lb. (2 kg)

DXF E027

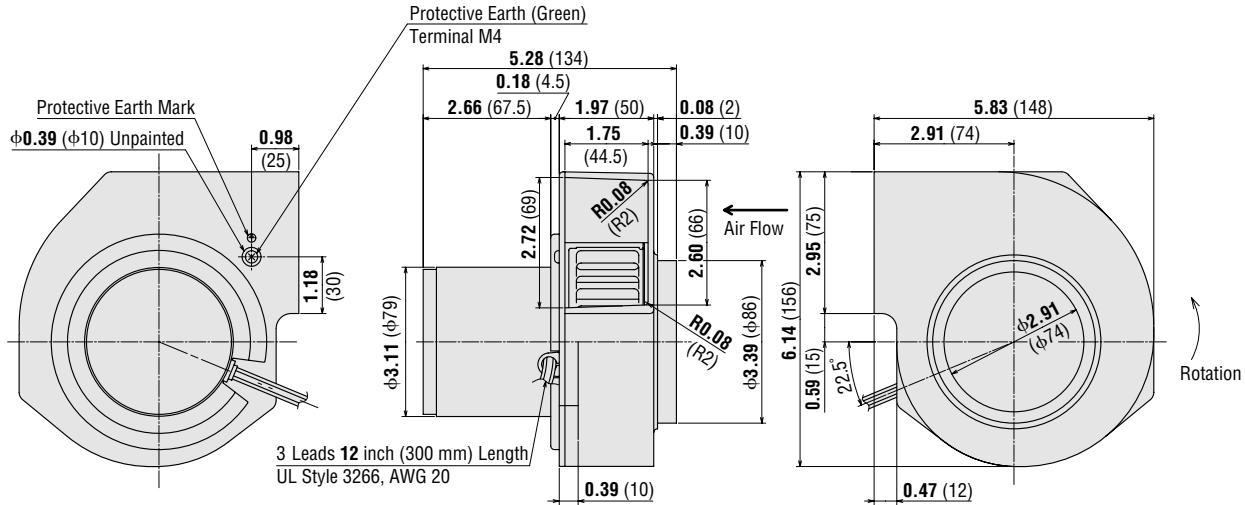

■ Panel Cut-Out Scale 1/4, Unit = inch (mm)

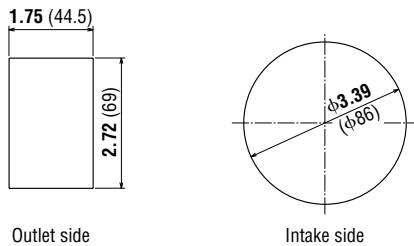

■ Connection Diagram

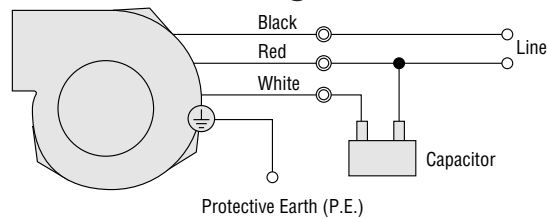

● How to connect a capacitor → Page E-113

■ Thermostats (Sold Separately)

Thermostats make it possible for fans to operate only when cooling is necessary, thereby conserving energy.



Thermostats: **AM1-WA1**
AM1-XA1

→ Page E-97

● Capacitor (Capacitor and capacitor cap are provided with the blower.)

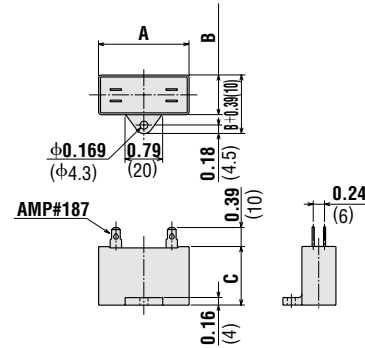

Model	Capacitor	Dimensions inch (mm)			Weight oz. (g)
		A	B	C	
MB1040-B	CH30BFAUL	2.28 (58)	0.83 (21)	1.22 (31)	1.77 (50)
MB1040-D	CH12BFAUL	1.46 (37)	0.71 (18)	1.06 (27)	1.06 (30)

■ Accessories (Sold Separately)

Item	Model	Safety Standards	Page
Finger Guard	FGB10	*	E-104
Filter	FLB10	—	E-106
Mounting Bracket	PAS4B	—	E-109
Duct Joint	FD10	—	E-110

* These products have been designed to pass tests set forth under the UL and CSA standards for equipment used in fans. They conform to the standards only when used with an **ORIX FAN**.

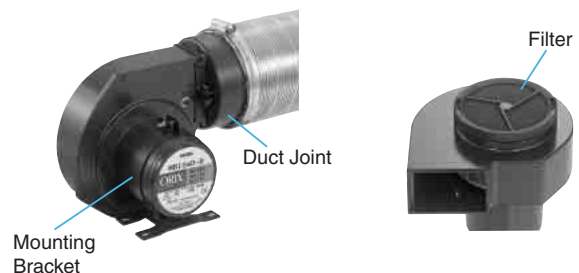

● A finger guard can be installed in place of the filter.

Introduction

MRS

Variable Flow

MU

Long Life MDE

MDS · MD

MB

MBD

MF

MFD

Thermostats

Accessories

Before Using a Fan

Axial Flow Fans

DC Input

AC Input

DC Input

AC Input

DC Input

Centrifugal Blowers

AC Input

DC Input

AC Input

DC Input

MB Series

AC Centrifugal Blowers

Impeller Diameter

φ3.15 in. (φ80 mm)



Ambient Temperature: 14°F to 122°F (−10°C to + 50°C)
Operating Voltage Range: ±10%

Materials

Motor Case: Die Cast Aluminum
Casing: Die Cast Aluminum
Impeller: Aluminum
Overheat Protection: Built-in Thermal Protector
Bearings: Ball Bearings

Specifications



Model	Voltage VAC	Frequency Hz	Current A	Input Power W	Speed r/min	Max. Air Flow		Max. Static Pressure		Noise Level dB(A)	Capacitor μF
						CFM	m ³ /min	inH ₂ O	Pa		
MB840-B	Single-Phase 100	50	0.29	28	2800	56.5	1.6	0.61	152	55	1.5
	Single-Phase 100	60	0.37	32	3150	63.5	1.8	0.886	221	58	
	Single-Phase 110	60	0.37	35	3300	63.5	1.8	0.906	226	59	
	Single-Phase 115	60	0.37	36	3350	63.5	1.8	0.906	226	59	
MB840-D	Single-Phase 200	50	0.14	28	2800	56.5	1.6	0.61	152	55	2.5
	Single-Phase 200	60	0.18	32	3200	63.5	1.8	0.886	221	58	
	Single-Phase 220	60	0.18	35	3350	63.5	1.8	0.906	226	59	
	Single-Phase 230	50	0.15	35	2850	56.5	1.6	0.63	157	55	
MB840-T	Single-Phase 230	60	0.18	36	3350	63.5	1.8	0.906	226	59	—
	Three-Phase 200	50	0.12	25	2800	56.5	1.6	0.61	152	55	
	Three-Phase 200	60	0.15	28	3200	63.5	1.8	0.886	221	58	
	Three-Phase 220	60	0.15	30	3350	63.5	1.8	0.906	226	59	
	Three-Phase 230	60	0.15	30	3350	63.5	1.8	0.906	226	59	

● **MB840-T** is conformed by UL and CSA standards. ● How to read the specifications →Page E-13 ● Details of safety standards →Page G-12

Air Flow — Static Pressure Characteristics

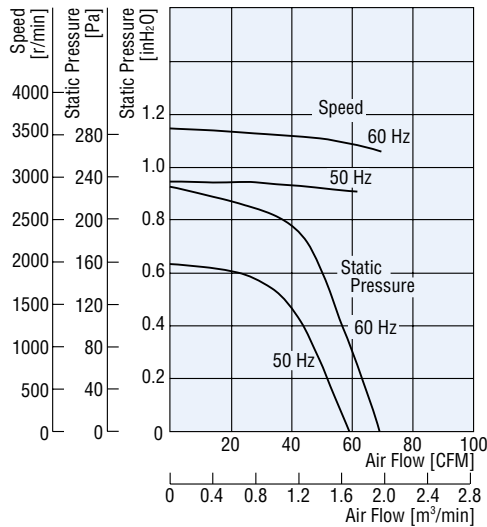

Frequency — Audible Noise Level (dB)

Measured at a distance of 3.3 feet (1 m) from the fan intake side

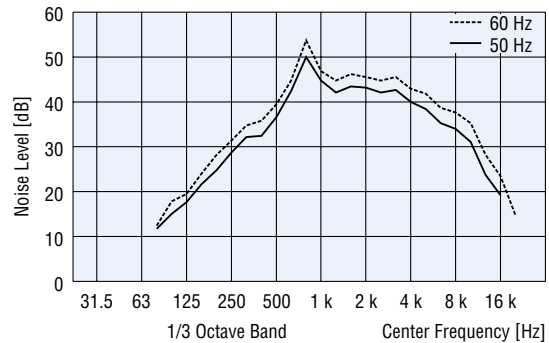

Dimensions Scale 1/4, Unit = inch (mm)

Weight: 2.9 lb. (1.3 kg)

DXF E062

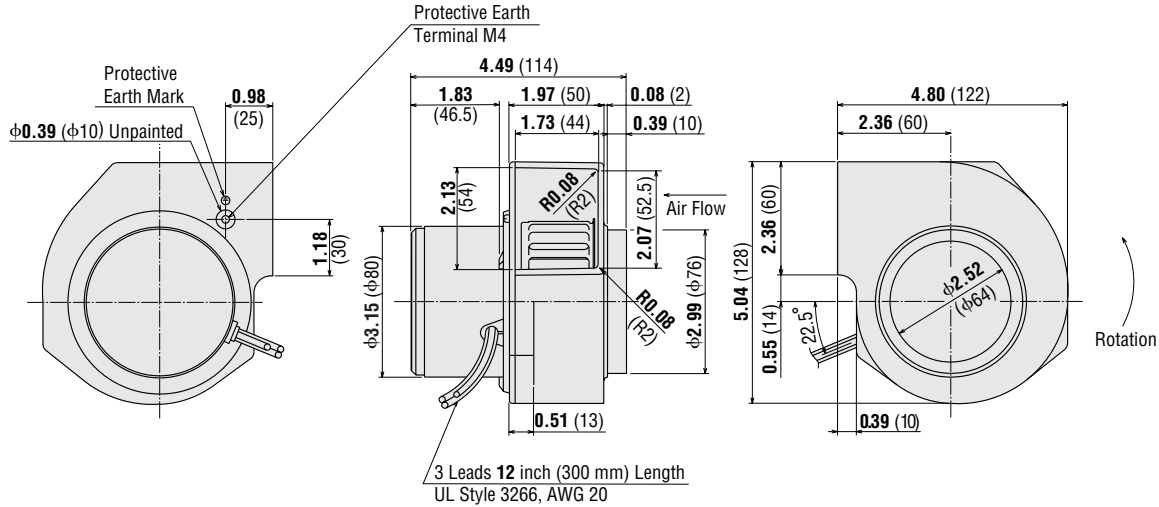

Panel Cut-Out Scale 1/4, Unit = inch (mm)

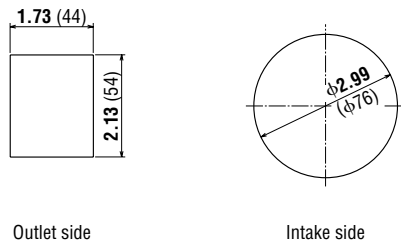

Connection Diagrams

● MB840-B, D Type

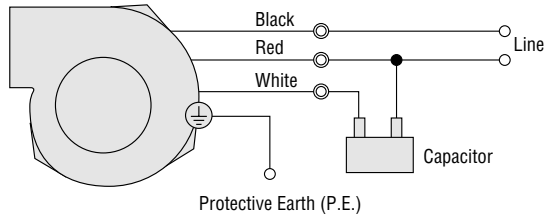

● How to connect a capacitor → Page E-113

● MB840-T Type

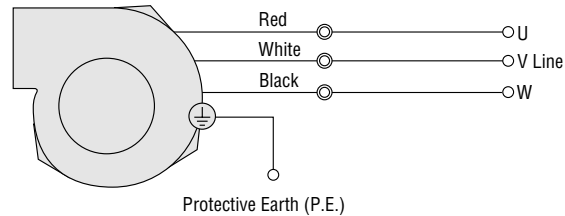

Thermostats (Sold Separately)

Thermostats make it possible for fans to operate only when cooling is necessary, thereby conserving energy.



Thermostats: **AM1-WA1**
AM1-XA1

→ Page E-97

● Capacitor (Capacitor and capacitor cap are provided with single-phase blowers.)

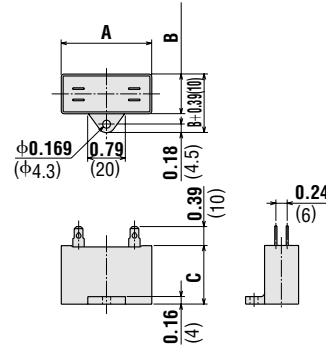

Model	Capacitor	Dimensions inch (mm)			Weight oz. (g)
		A	B	C	
MB840-B	CH15FAUL	1.22 (31)	0.57 (14.5)	0.93 (23.5)	1.24 (35)
MB840-D	CH25FAUL	1.22 (31)	0.67 (17)	1.06 (27)	1.41 (40)

Accessories (Sold Separately)

Item	Model	Safety Standards	Page
Finger Guard	FGB8	*	E-104
Filter	FLB8	—	E-106
Mounting Bracket	PAS4B	—	E-109
Duct Joint	FD8	—	E-110

* These products have been designed to pass tests set forth under the UL and CSA standards for equipment used in fans. They conform to the standards only when used with an **ORIX FAN**.

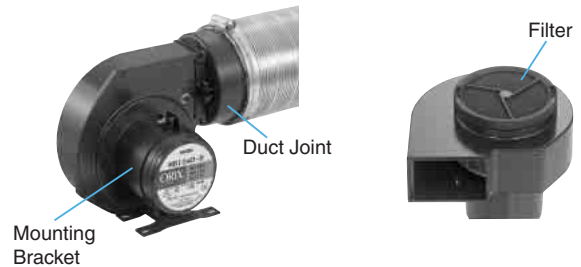

● A finger guard can be installed in place of the filter.

Introduction

MRS

Variable Flow

MU

Long Life

MDE

MDS · MD

MB

MDB

MF

MFD

Thermostats

Accessories

Before Using a Fan

MB Series

AC Centrifugal Blowers

Impeller Diameter

ϕ2.36 in. (ϕ60 mm)



Ambient Temperature: 14°F to 122°F (−10°C to +50°C)
Operating Voltage Range: ±10%

Materials

Motor Case: Die Cast Aluminum
Casing: Die Cast Aluminum
Impeller: Aluminum
Overheat Protection: Impedance Protection
Bearings: Ball Bearings

Specifications



Model	Voltage VAC	Frequency Hz	Current A	Input Power W	Speed r/min	Max. Air Flow		Max. Static Pressure		Noise Level dB(A)
						CFM	m ³ /min	inH ₂ O	Pa	
MB630-B	Single-Phase 100	50	0.11	8.0	2300	15.5	0.44	0.213	53	37
	Single-Phase 100	60	0.11	8.0	1900	12.7	0.36	0.305	76	33
	Single-Phase 110	60	0.12	9.5	2300	15.9	0.45	0.309	77	38
	Single-Phase 115	60	0.12	10.0	2500	17.3	0.49	0.317	79	40
MB630-D	Single-Phase 200	50	0.08	12.0	2500	17.3	0.49	0.225	56	38
	Single-Phase 200	60	0.08	11.0	2600	17.7	0.50	0.333	83	39
	Single-Phase 220	60	0.08	13.0	2900	19.4	0.55	0.333	83	42
	Single-Phase 230	50	0.09	16.0	2600	17.7	0.50	0.225	56	39
	Single-Phase 230	60	0.08	14.0	2900	19.4	0.55	0.333	83	43

•How to read the specifications →Page E-13 •Details of safety standards →Page G-12

Air Flow — Static Pressure Characteristics

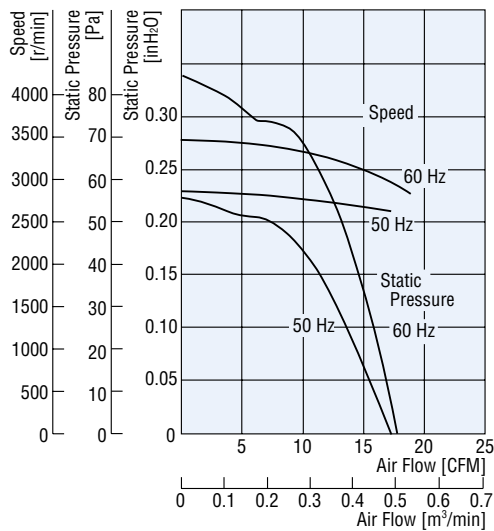

Frequency — Audible Noise Level (dB)

Measured at a distance of 3.3 feet (1 m) from the fan intake side

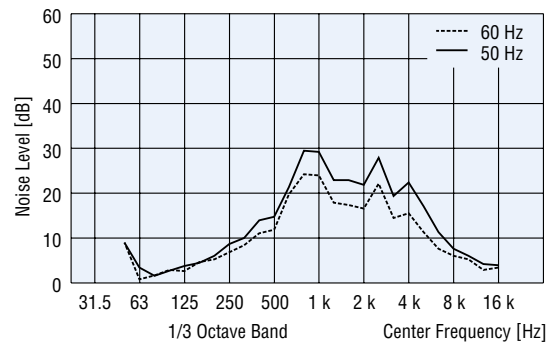

Dimensions Scale 1/4, Unit = inch (mm)

Weight: 1.1 lb. (0.5 kg)

DXF E063

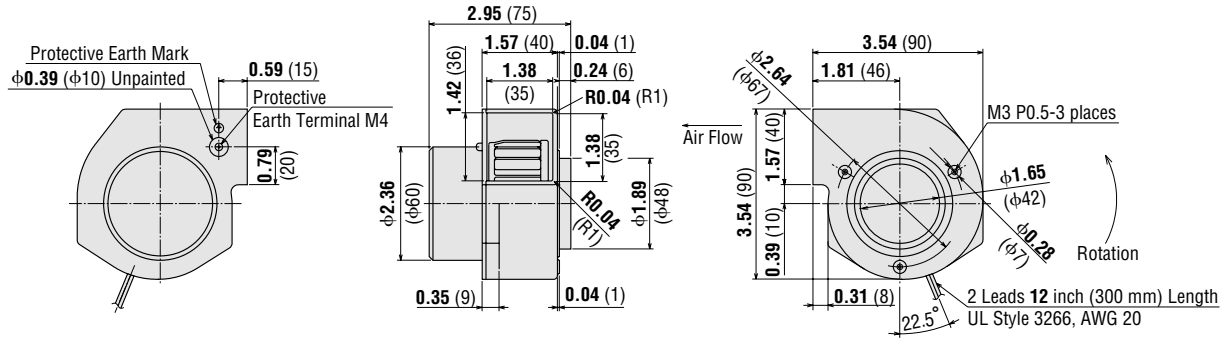

Panel Cut-Out Scale 1/4, Unit = inch (mm)

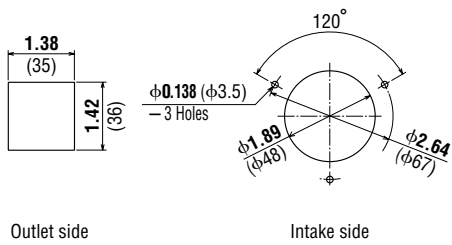

Outlet side

Intake side

Connection Diagram

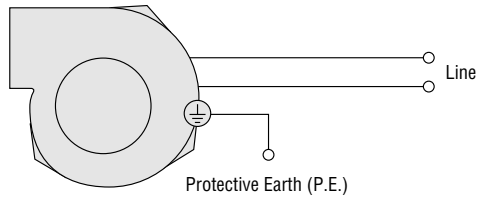

Accessories (Sold Separately)

Item	Model	Safety Standards	Page
Mounting Bracket	PAS2B	—	E-109

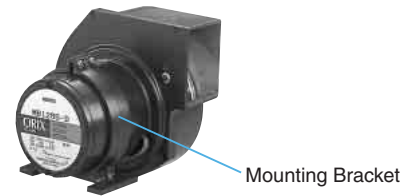

Thermostats (Sold Separately)

Thermostats make it possible for fans to operate only when cooling is necessary, thereby conserving energy.



Thermostats: **AM1-WA1**
AM1-XA1
→Page E-97

Introduction

MRS

Variable Flow

MU

Long Life

MDS - MD

MB

MBD

MF

MFD

Thermostats

Accessories

Before Using a Fan

MB Series

AC Centrifugal Blowers

Impeller Diameter

φ1.97 in. (φ50 mm)



Ambient Temperature: 14°F to 122°F (−10°C to +50°C)
Operating Voltage Range: ±10%

Materials

Motor Case: Die Cast Aluminum
Casing: Die Cast Aluminum
Impeller: Aluminum
Overheat Protection: Impedance Protection
Bearings: Ball Bearings

Specifications



Model	Voltage VAC	Frequency Hz	Current A	Input Power W	Speed r/min	Max. Air Flow		Max. Static Pressure		Noise Level dB(A)
						CFM	m ³ /min	inH ₂ O	Pa	
MB520-B	Single-Phase 100	50	0.11	8.0	2600	7.41	0.21	0.149	37	33
	Single-Phase 100	60	0.10	7.0	3000	8.47	0.24	0.213	53	37
	Single-Phase 110	60	0.11	8.5	3200	8.83	0.25	0.221	55	38
	Single-Phase 115	60	0.11	9.0	3200	8.83	0.25	0.221	55	38
MB520-D	Single-Phase 200	50	0.09	11.0	2650	7.77	0.22	0.153	38	33
	Single-Phase 200	60	0.08	10.0	3200	9.53	0.27	0.233	58	38
	Single-Phase 220	60	0.09	12.0	3300	9.53	0.27	0.241	60	38
	Single-Phase 230	50	0.10	16.0	2750	8.12	0.23	0.16	40	33
	Single-Phase 230	60	0.09	13.0	3300	9.53	0.27	0.241	60	38

•How to read the specifications →Page E-13 •Details of safety standards →Page G-12

Air Flow — Static Pressure Characteristics

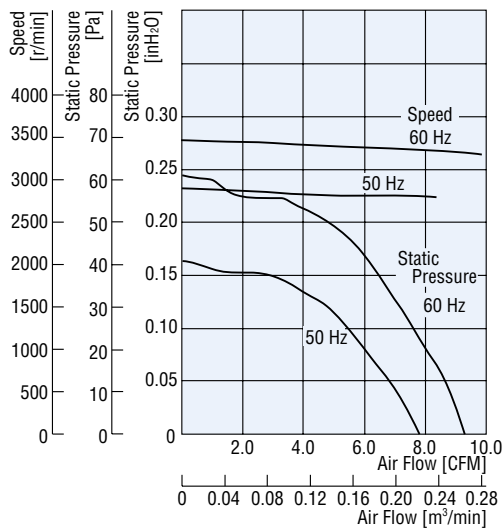

Frequency — Audible Noise Level (dB)

Measured at a distance of 3.3 feet (1 m) from the fan intake side

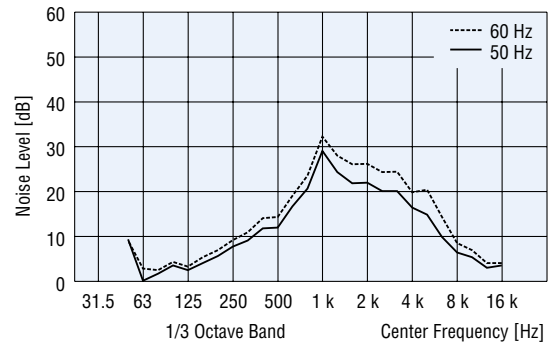

Dimensions Scale 1/4, Unit = inch (mm)

Weight: 0.7 lb. (0.3 kg)

DXF E064

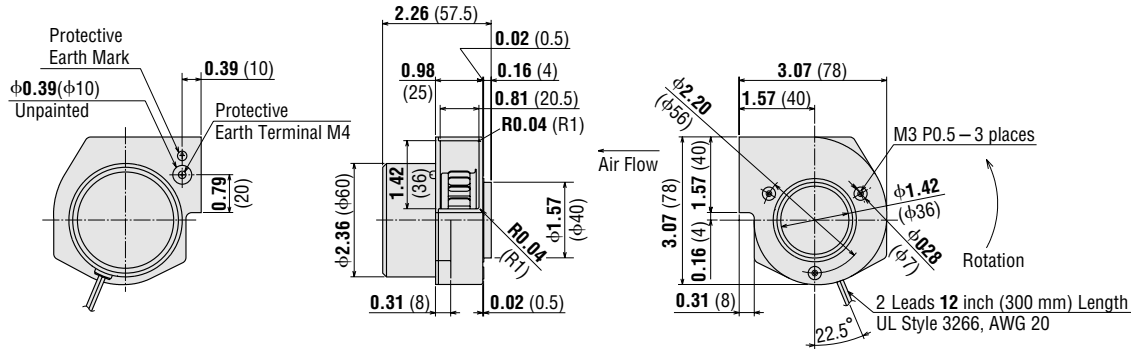

Panel Cut-Out Scale 1/4, Unit = inch (mm)

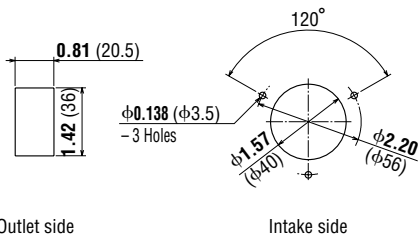

Outlet side

Intake side

Connection Diagram

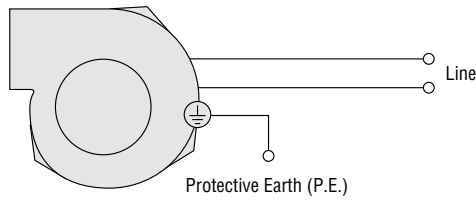

Accessories (Sold Separately)

Item	Model	Safety Standards	Page
Mounting Bracket	PAS2B	—	E-109

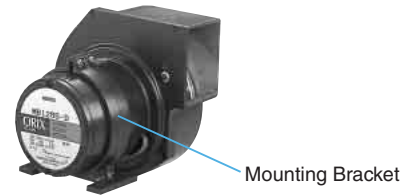

Thermostats (Sold Separately)

Thermostats make it possible for fans to operate only when cooling is necessary, thereby conserving energy.



Thermostats: **AM1-WA1**
AM1-XA1

→Page E-97

Introduction

MRS

Variable AC Input Flow

MU

Long Life MDE

MDS · MD

MB

MBD

MF

MFD

Thermostats

Accessories

Before Using a Fan