

REVISIONS

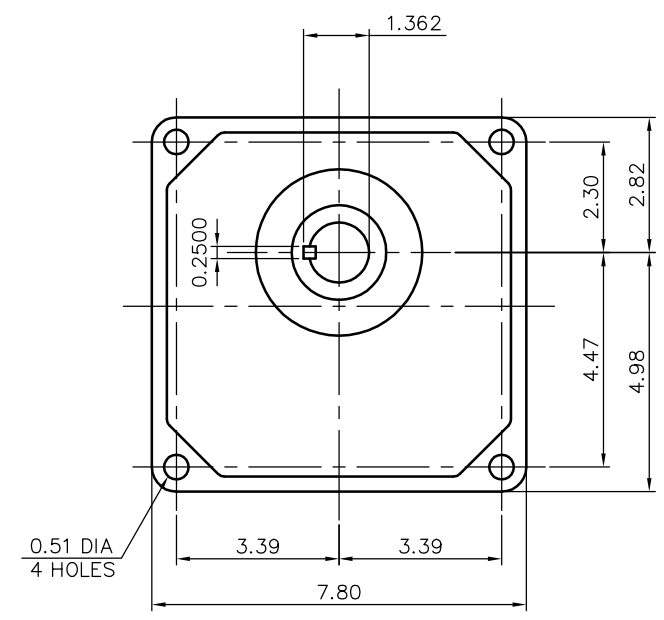
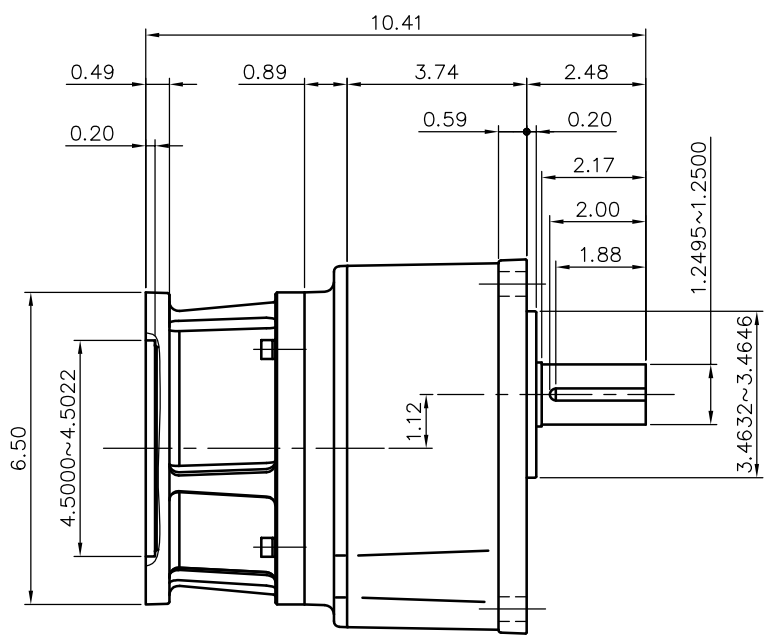
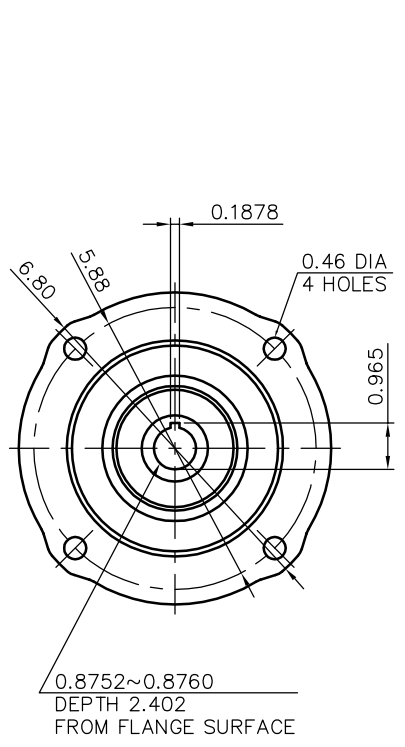

REDUCER SPECIFICATION

TYPE	GTR		
FORM	32		
RATIO	1/5	1/10	1/15 1/20
	1/25		
LUBRICATION	GREASE		
CORRESPONDING MOTOR CAPACITY AT 4POLES	2 HP		

TITLE		G3K32N005~025-NDP DIMENSION OF MODEL		
DRAWING NO. G3K32N-NDP				
USER				
NOTICE				
APPROVE	H.Hayashi	SCALE	UNIT	DATE
CHECK	A.Hayakawa	1/4	in	2017.08.28
DESIGN	M.Suzuki	NISSEI CORPORATION		