

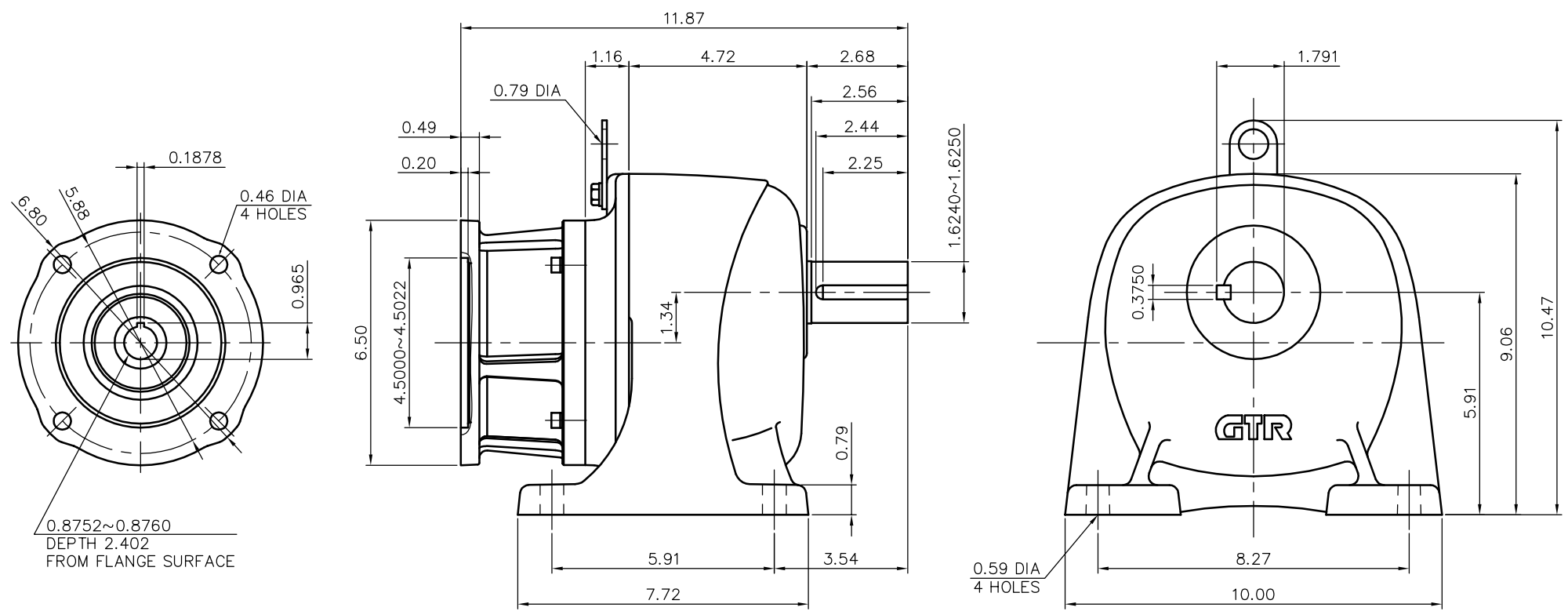

REVISIONS



REDUCER SPECIFICATION

TYPE	GTR		
FORM	40		
RATIO	1/30	1/40	1/50 1/60
	1/80		
LUBRICATION	GREASE		
CORRESPONDING MOTOR CAPACITY AT 4POLES	2 HP		

TITLE	G3L40N030~080-NDP DIMENSION OF MODEL		
DRAWING NO.	G3L40N-NDP		
USER			
NOTICE			
APPROVE	H.Hayashi	SCALE	 UNIT in DATE 2017.08.28
CHECK	A.Hayakawa	1/4	
DESIGN	M.Suzuki		
NISSEI CORPORATION			