

REVISIONS

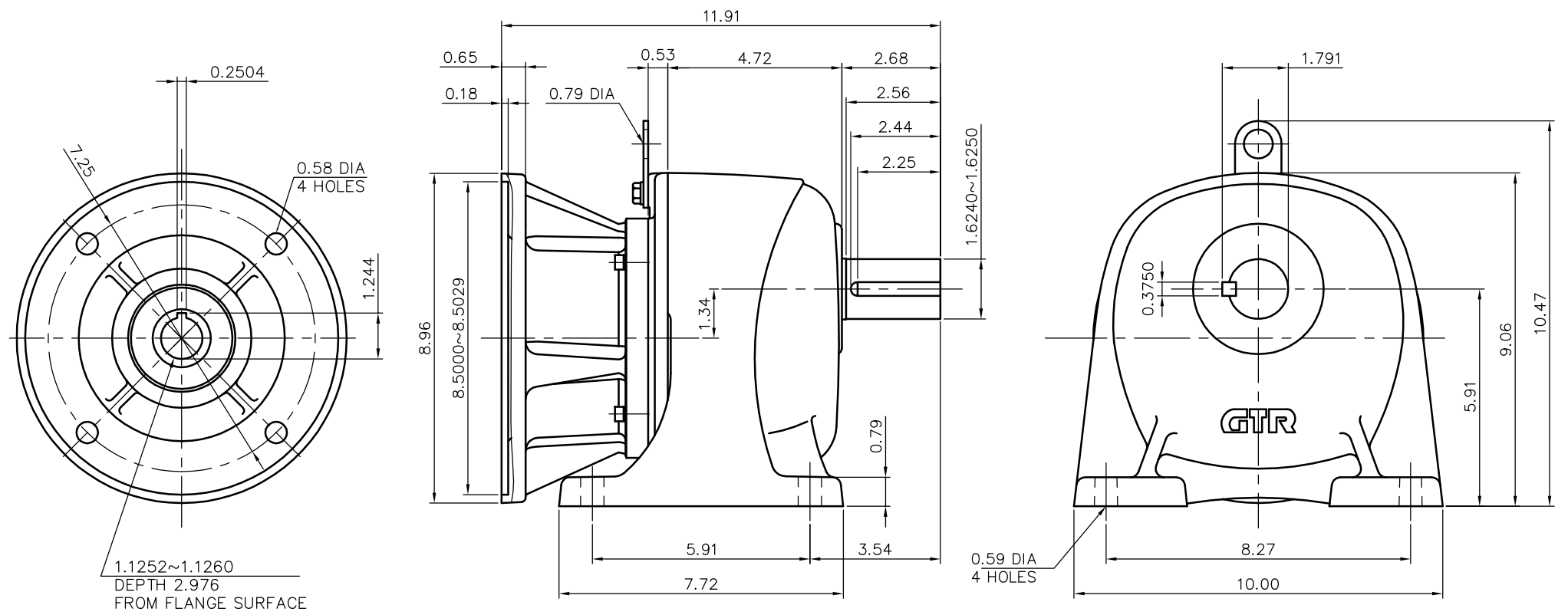

REDUCER SPECIFICATION

TYPE	GTR		
FORM	40		
RATIO	1/5	1/10	1/15 1/20
	1/25		
LUBRICATION	GREASE		
CORRESPONDING MOTOR CAPACITY AT 4POLES	3 HP		

TITLE	G3L40N005~025-NER DIMENSION OF MODEL				
DRAWING NO.	G3L40N-NER				
USER					
NOTICE					
APPROVE	H.Hayashi	SCALE		UNIT	DATE
CHECK	A.Hayakawa	1/4		in	2017.08.28
DESIGN	M.Suzuki	NISSEI CORPORATION			