

REVISIONS

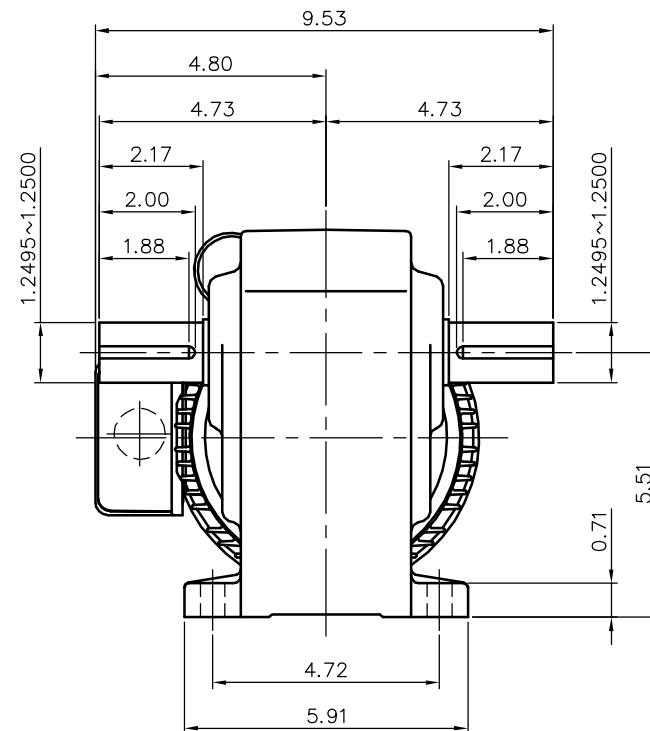
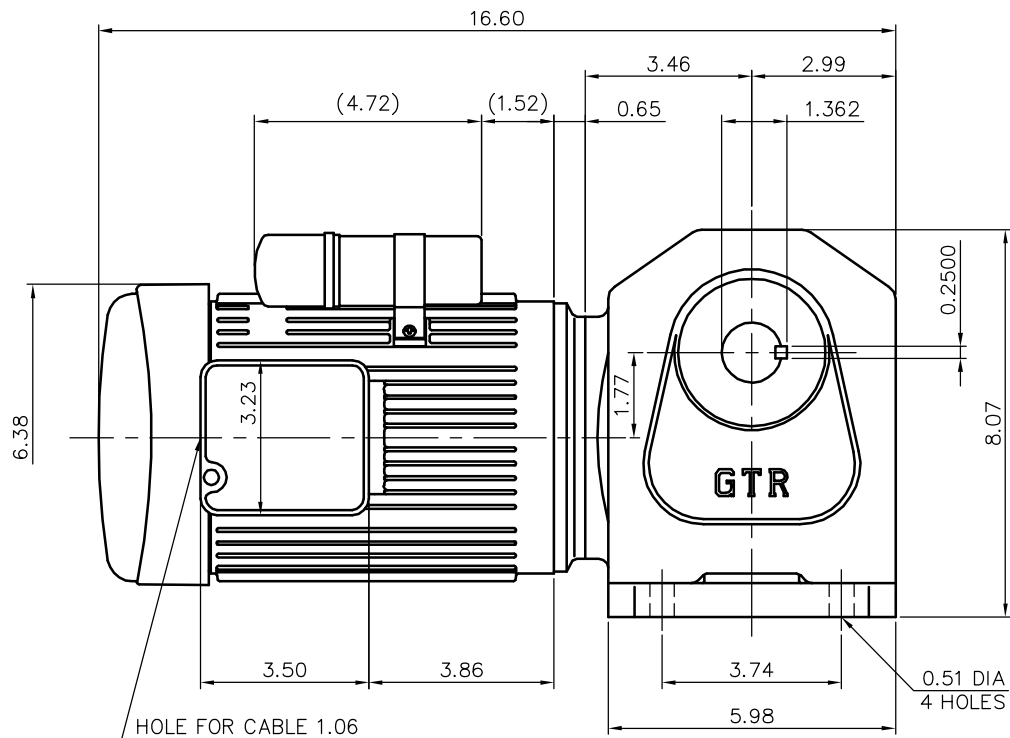

MOTOR SPECIFICATION

TYPE	1-PHASE INDUCTION MOTOR
FORM	TOTALLY ENCLOSED FAN COOLED TECA13
OUT PUT	1/2 HP
VOLTAGE	115 V
FREQ	50/60 Hz
POLES	4
RATING	CONT.

REDUCER SPECIFICATION

TYPE	GTR
FORM	32T
RATIO	1/80 1/100 1/120 1/160 1/200 1/240
LUBRICATION	GREASE

NOTE: THIS MOTOR IS AFFIXED WITH CE MARKING.
 NOTE: BE SURE TO USE THE THERMAL RELAY WITH CE MARKING.
 NOTE: THE GROUND LEAD SHOULD BE LONGER THAN THE SUPPLY LEAD FOR THE MOTOR.
 NOTE: INSULATION : CLASS A
 NOTE: THIS MOTOR IS UL CERTIFIED MODEL.(UL1004)
 NOTE: UL-LISTED MODEL NAME: BML1S

TITLE					H2L32T080~240-BML1S DIMENSION OF MODEL				
DRAWING NO. H2L32T-BML1S									
USER									
NOTICE									
APPROVE	K.Nagasaka	SCALE	1/4		UNIT	DATE			
CHECK	Y.Shiina				in	2008.02.15			
DESIGN	M.Yoshida				NISSEI CORPORATION				