

REVISIONS

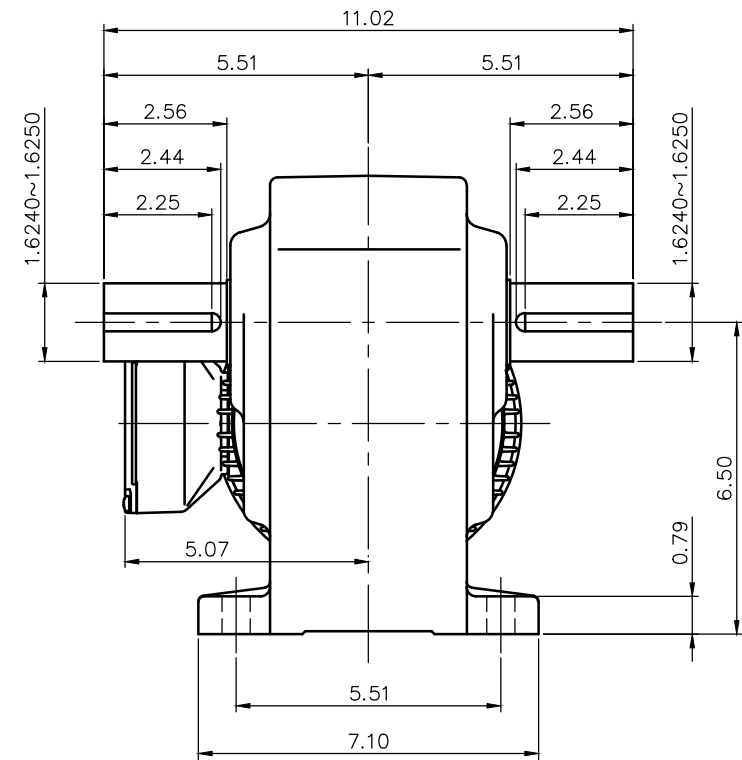
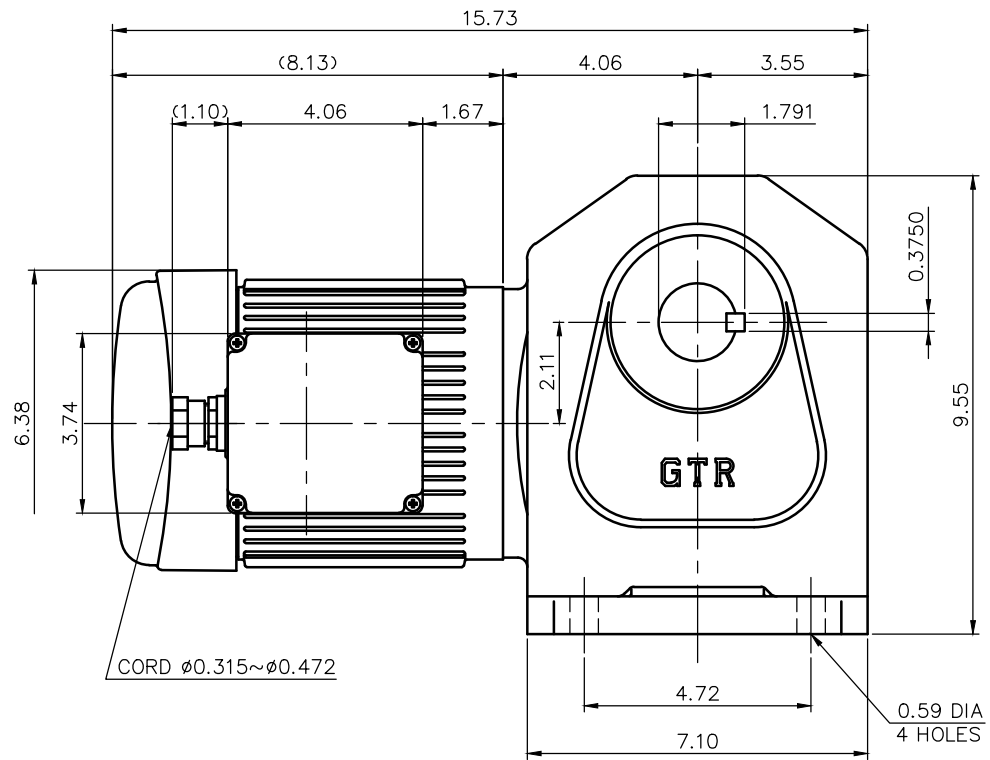

NOTE: THE ATTACHED RECTIFIER IS USED FOR DC POWER SUPPLY TO THE BRAKE COIL.  
 NOTE: THE BRAKE LEADS ARE PULLED INTO THE TERMINAL BOX.

NOTE: THIS MOTOR IS AFFIXED WITH CE MARKING.  
 NOTE: THE GROUND LEAD SHOULD BE LONGER THAN THE SUPPLY LEAD FOR THE MOTOR.  
 NOTE: THIS MOTOR IS UL CERTIFIED MODEL.(UL1004-1)  
 NOTE: UL-LISTED MODEL NAME: MF5AWB4

BRAKE SPECIFICATION

TYPE	BS3-08U-180
BRAKE TYPE	SPRING CLOSE
INPUT VOLTAGE	DC 207V
POWER CONSUMPTION	34 W (at 75°C)
BRAKE TORQUE	52.0 in-lbs

MOTOR SPECIFICATION

TYPE	3-PHASE INDUCTION MOTOR
FORM	TOTALLY ENCLOSED FAN COOLED
OUT PUT	3/4 HP
VOLTAGE	208/230/460/400 V
FREQ.	60/60/60/50 Hz
POLES	4
ROTATIONAL FREQUENCY	1800/1800/1800/1500 rpm
RATING	S1 CONT.
INS.CLASS	F

REDUCER SPECIFICATION

TYPE	GTR
FORM	40T
RATIO	1/80 1/100 1/120 1/160 1/200 1/240
LUBRICATION	GREASE

TITLE		H2L40T80~240-MF5AWB4			
		DIMENSION OF MODEL			
DRAWING NO.		H2L40T-MF5AWB4			
USER					
NOTICE					
APPROVE	Y.Ikeda	SCALE	1/4	UNIT in	DATE 2016.10.16
CHECK	Y.Sanji				
DESIGN	A.Kubota				
		NISSEI CORPORATION			