

REVISIONS

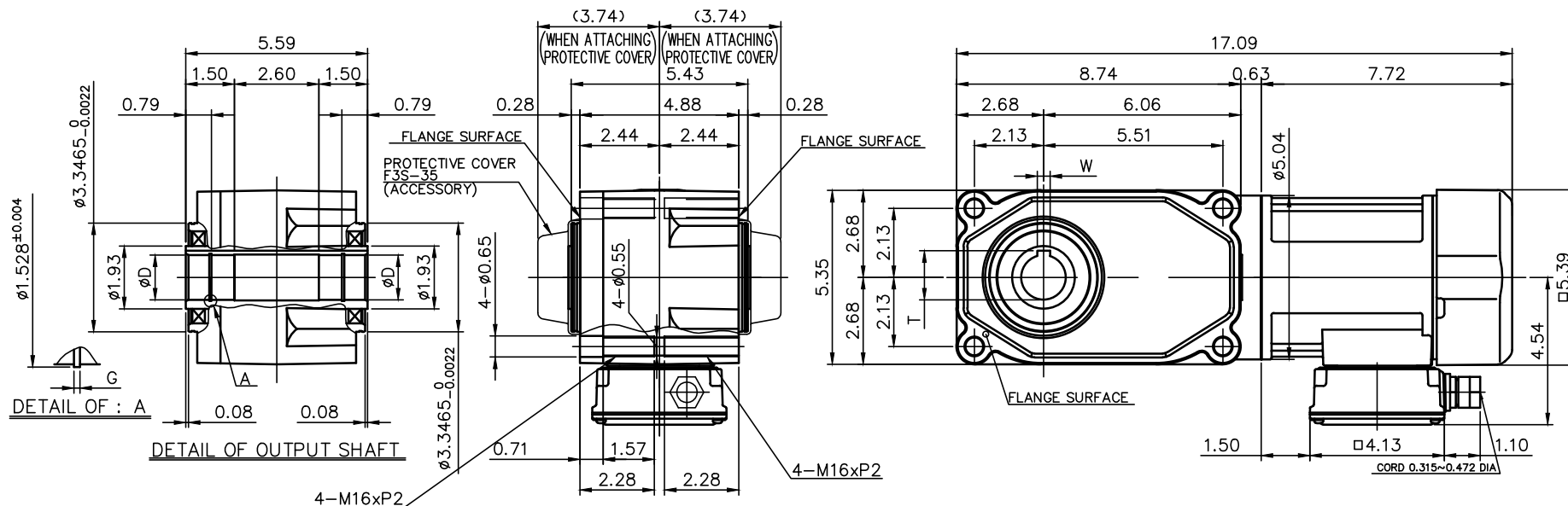

モータ仕様 MOTOR SPECIFICATION	
名称 TYPE	三相誘導電動機 THREE PHASE INDUCTION MOTOR
冷却方式 COOLING METHOD	全閉外扇形 TOTALLY ENCLOSED FAN COOLED
出力 MOTOR POWER	1/2 HP (0.4 kW)
定格 RATING	S1 CONT.
耐熱クラス INS. CLASS	F
保護構造 IP RATING	IP 44

モータ仕様 MOTOR SPECIFICATION						
**	電圧 VOLTAGE	周波数 FREQUENCY	回転速度 ROTATION SPEED	電流値 CURRENT VALUE	対応規格 COMPLIANT STANDARDS	高効率認証 EFFICIENCY STANDARDS
AV	208 V	60 Hz	1680 r/min	1.8 A	UL/cUL/CE	-
	230 V	60 Hz	1720 r/min	1.8 A		
	460 V	60 Hz	1720 r/min	0.9 A		
	400 V	50 Hz	1400 r/min	1.0 A		
EV	415 V	50 Hz	1390 r/min	0.96 A		
	440 V	50 Hz	1410 r/min	0.95 A		
	480 V	60 Hz	1680 r/min	0.82 A		

減速機仕様 REDUCER SPECIFICATION		
名称 TYPE	GTR	
枠番 FRAME NO.	35	
減速比 RATIO	80 100 120 160 200 240	
潤滑 LUBRICATION	グリース GREASE	
塗装 PAINT COLOR	グレー (マンセル値 9B6/0.5) GREY (MANSEL CODE: 9B6/0.5)	

電磁ブレーキ仕様 BRAKE SPECIFICATION	
型式 MODEL	O40_B4
方式 BRAKE TYPE	無励磁作動形 (スプリングクローズ) POWER-OFF (SPRING CLOSE)
励磁電圧 INPUT VOLTAGE	DC180V
容量 POWER CONSUMPTION	14W (AT 75℃)
静摩擦トルク STATIC FRICTION TORQUE	34.70 in-lb
動摩擦トルク DYNAMIC FRICTION TORQUE	27.79 in-lb

出力軸仕様 OUTPUT SHAFT SPECIFICATION						
FRAME NO	D	STANDARD /OPTION	DIAMETER TOLERANCE	T	W	G
35	1.2500 in	STANDARD	+0.0013/+0.0	1.366 in	0.2500 in	0.056 in
	1.0000 in	OPTION	+0.0013/+0.0	1.114 in	0.2500 in	0.046 in
	1.3750 in	OPTION	+0.0015/+0.0	1.520 in	0.3125 in	0.056 in
	1.4375 in	OPTION	+0.0015/+0.0	1.606 in	0.3750 in	0.056 in
	35 mm	OPTION	+0.039/+0.0	38.3 mm	10 mm	1.75 mm

- 製品型式「□□□」は減速比によって入る文字数が変わります。  
Number of characters on product model「□□□」, varies depending on the reduction ratio.
- 製品型式「\*\*」には「AV」「EV」が入ります。  
Replace product model「\*\*」 with 「AV」「EV」.

TITLE	F3S35N□□□-MB04T* *EB4 外形寸法図 DIMENSION OF MODEL				
DRAWING NO.	F3S35N-MB04TEB4				
USER					
NOTICE					
APPROVE	H.Hayashi	SCALE	1:5	UNIT	in
CHECK	M.Iijima			DATE	2020.03.31
DESIGN	A.Kobayashi			NISSEI CORPORATION	