

REVISIONS

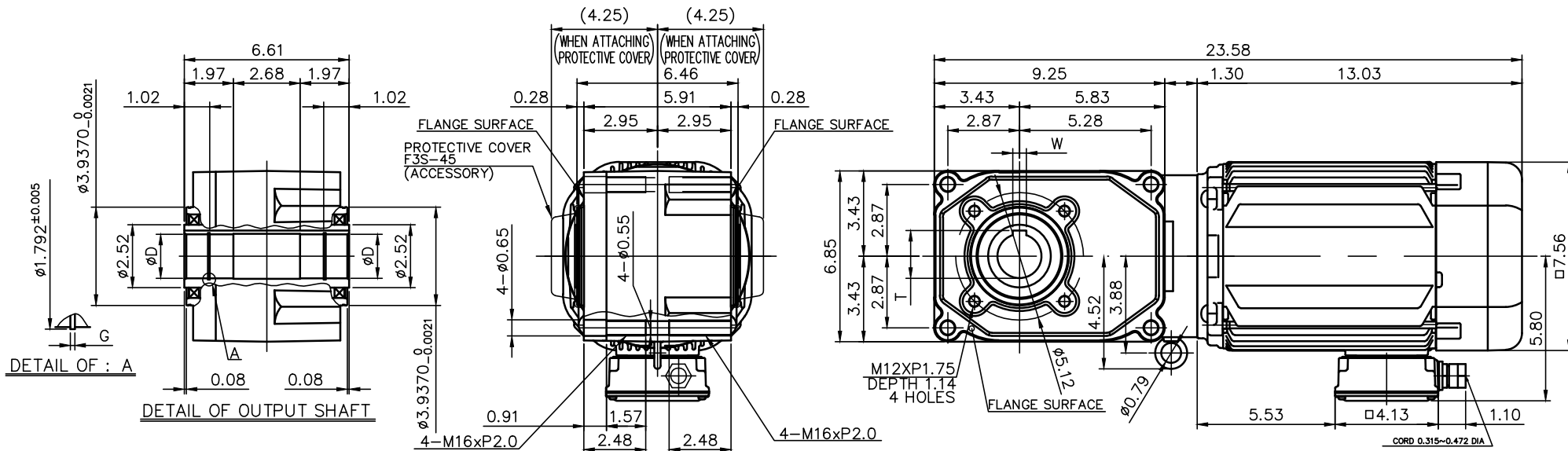

モータ仕様 MOTOR SPECIFICATION	
名称 TYPE	三相誘導電動機 THREE PHASE INDUCTION MOTOR
冷却方式 COOLING METHOD	全閉外扇形 TOTALLY ENCLOSED FAN COOLED
出力 MOTOR POWER	3 HP (2.2 kW)
定格 RATING	S1 CONT.
耐熱クラス INS. CLASS	F
保護構造 IP RATING	IP 44

モータ仕様 MOTOR SPECIFICATION						
**	電圧 VOLTAGE	周波数 FREQUENCY	回転速度 ROTATION SPEED	電流値 CURRENT VALUE	対応規格 COMPLIANT STANDARDS	高効率認証 EFFICIENCY STANDARDS
AV	208 V	60 Hz	1750 r/min	8.3 A	UL/cUL/CE	<IE3> USA/CANADA
	230 V	60 Hz	1770 r/min	7.9 A		
	460 V	60 Hz	1770 r/min	4.0 A		
	400 V	50 Hz	1470 r/min	4.5 A		
EV	415 V	50 Hz	1460 r/min	4.3 A		
	440 V	50 Hz	1470 r/min	4.3 A		
	480 V	60 Hz	1770 r/min	3.8 A		

減速機仕様 REDUCER SPECIFICATION		
名称 TYPE	GTR	
枠番 FRAME NO.	45	
減速比 RATIO	5 7.5 10 12.5 15 20 25 30	
潤滑 LUBRICATION	グリース GREASE	
塗装 PAINT COLOR	グレー (マンセル値 9B6/0.5) GREY (MANSEL CODE: 9B6/0.5)	

出力軸仕様 OUTPUT SHAFT SPECIFICATION						
FRAME NO	D	STANDARD /OPTION	DIAMETER TOLERANCE	T	W	G
45	1.3750 in	STANDARD	+0.0015/+0.0	1.520 in	0.3125 in	0.056 in
	1.5000 in	OPTION	+0.0015/+0.0	1.669 in	0.3750 in	0.056 in
	1.6875 in	OPTION	+0.0015/+0.0	1.858 in	0.3750 in	0.068 in
	45 mm	OPTION	+0.039/+0.0	48.8 mm	14 mm	1.95 mm

電磁ブレーキ仕様 BRAKE SPECIFICATION	
型式 MODEL	220_B4
方式 BRAKE TYPE	無励磁作動形 (スプリングクローズ) POWER-OFF (SPRING CLOSE)
励磁電圧 INPUT VOLTAGE	DC180V
容量 POWER CONSUMPTION	27W (AT 75°C)
静摩擦トルク STATIC FRICTION TORQUE	191 in-lb
動摩擦トルク DYNAMIC FRICTION TORQUE	152 in-lb

- 製品型式「□□□」は減速比によって入る文字数が変わります。
Number of characters on product model「□□□」, varies depending on the reduction ratio.
- 製品型式「**」には「AV」「EV」が入ります。
Replace product model「**」 with 「AV」「EV」.

TITLE	F3S45N□□□-MB22T* *EB4 外形寸法図 DIMENSION OF MODEL				
DRAWING NO.	F3S45N-MB22TEB4				
USER					
NOTICE					
APPROVE	H.Hayashi	SCALE	1:6	UNIT	in
CHECK	M.Iijima			DATE	2020.03.31
DESIGN	A.Kobayashi			NISSEI CORPORATION	