

REVISIONS

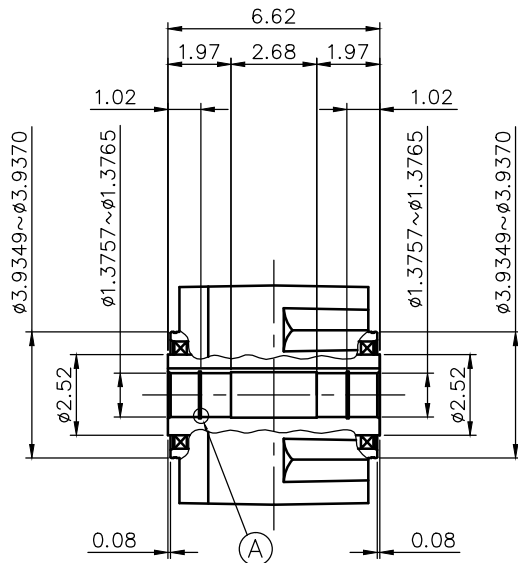

DETAIL OF OUTPUT SHAFT

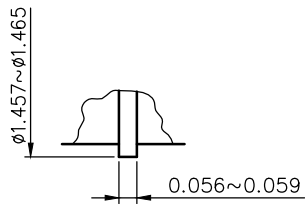

DETAIL OF : A

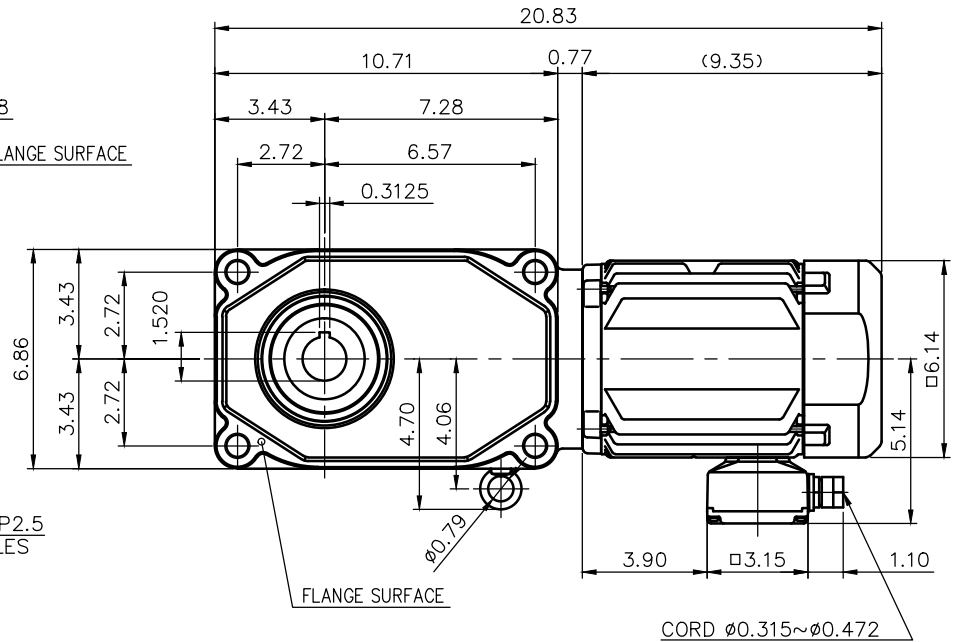
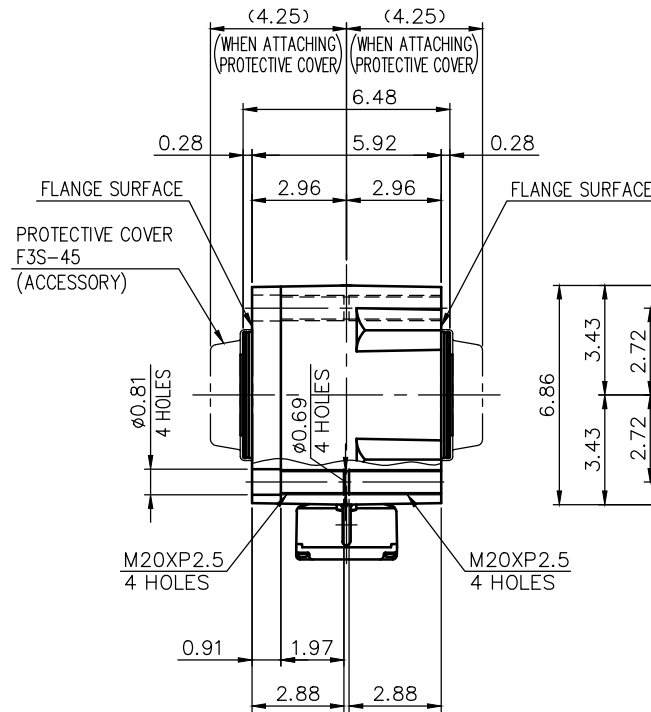

NOTE: THE BRAKE LEADS ARE PULLED INTO THE TERMINAL BOX.  
NOTE: THE ATTACHED RECTIFIER IS USED FOR DC POWER SUPPLY TO THE BRAKE COIL.

NOTE: THIS MOTOR IS AFFIXED WITH CE MARKING.  
NOTE: THE GROUND LEAD SHOULD BE LONGER THAN THE SUPPLY LEAD FOR THE MOTOR.  
NOTE: THIS MOTOR IS UL CERTIFIED MODEL. (UL1004-1)  
NOTE: UL-LISTED MODEL NAME: MV6AEB4

BRAKE SPECIFICATION

TYPE	BS3-08-180
BRAKE TYPE	SPRING CLOSE
INPUT VOLTAGE	DC 207V
POWER CONSUMPTION	34 W (at 75 °C)
BRAKE TORQUE	52.0 in-lbs

MOTOR SPECIFICATION

TYPE	3-PHASE INDUCTION MOTOR
FORM	TOTALLY ENCLOSED FAN COOLED P6
OUT PUT	1 HP
VOLTAGE	208/230/460/400 V
FREQ.	60/60/60/50 Hz
POLES	4
ROTATIONAL FREQUENCY	1800/1800/1800/1500 rpm
EFFICIENCY CLASS	IE3 EN60034-30 Standard
RATING	S1 CONT.
INS.CLASS	F

REDUCER SPECIFICATION

TYPE	GTR
FORM	45
RATIO	1/80 1/100 1/120 1/160 1/200 1/240
LUBRICATION	GREASE

TITLE F3S45N80~240-MV6AEB4 DIMENSION OF MODEL					
DRAWING NO.		F3S45N-MV6AEB4			
USER					
NOTICE					
APPROVE	Y.Ikeda	SCALE	1/6	UNIT in	
CHECK	M.Iijima	DATE			2015.05.01
DESIGN	Y.Miura	NISSEI CORPORATION			