

REVISIONS

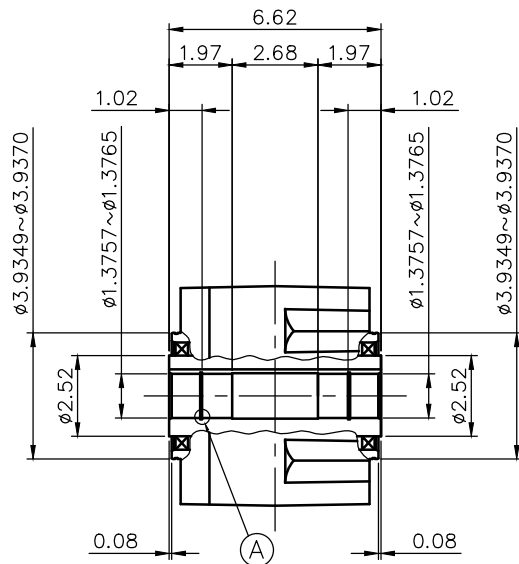

DETAIL OF OUTPUT SHAFT

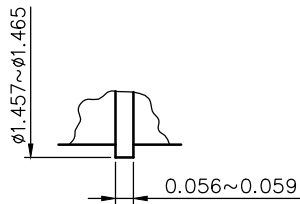

DETAIL OF : A

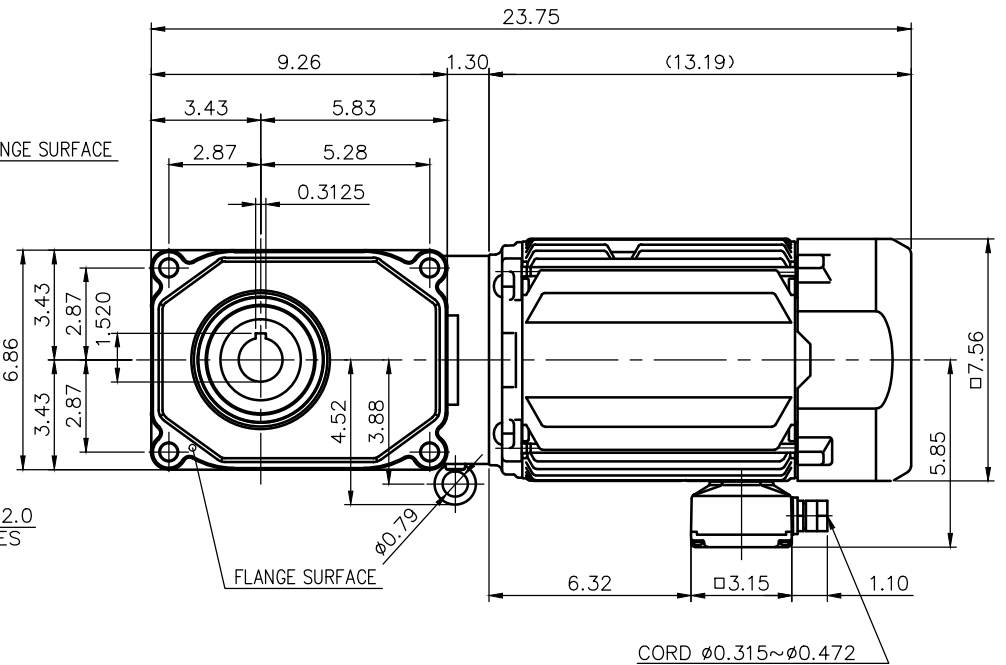
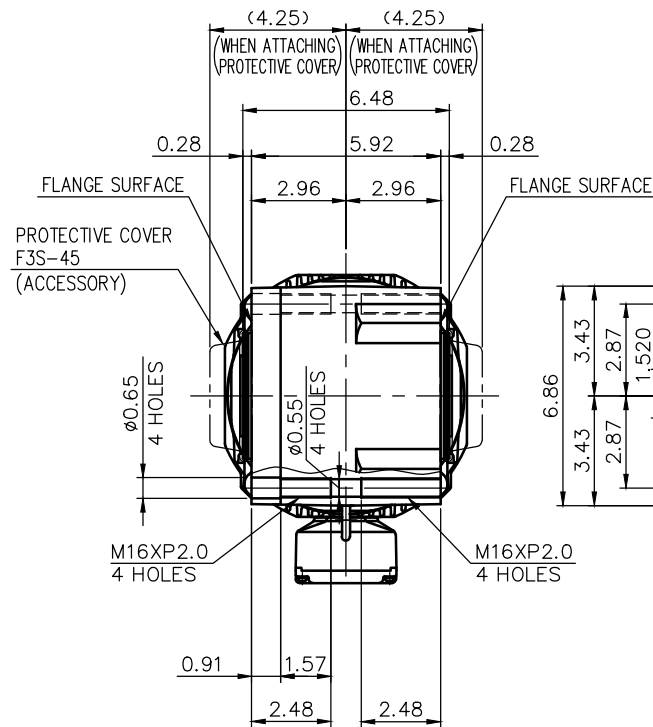

NOTE: THE BRAKE LEADS ARE PULLED INTO THE TERMINAL BOX.  
 NOTE: THE ATTACHED RECTIFIER IS USED FOR DC POWER SUPPLY TO THE BRAKE COIL.

NOTE: THIS MOTOR IS AFFIXED WITH CE MARKING.  
 NOTE: THE GROUND LEAD SHOULD BE LONGER THAN THE SUPPLY LEAD FOR THE MOTOR.  
 NOTE: THIS MOTOR IS UL CERTIFIED MODEL. (UL1004-1)  
 NOTE: UL-LISTED MODEL NAME: MV9AEB4

BRAKE SPECIFICATION

TYPE	BS3-22-180
BRAKE TYPE	SPRING CLOSE
INPUT VOLTAGE	DC 207V
POWER CONSUMPTION	49 W (at 75 °C)
BRAKE TORQUE	152.7 in-lbs

MOTOR SPECIFICATION

TYPE	3-PHASE INDUCTION MOTOR
FORM	TOTALLY ENCLOSED FAN COOLED P9
OUT PUT	3 HP
VOLTAGE	208/230/460/400 V
FREQ.	60/60/60/50 Hz
POLES	4
ROTATIONAL FREQUENCY	1800/1800/1800/1500 rpm
EFFICIENCY CLASS	IE3 EN60034-30 Standard
RATING	S1 CONT.
INS.CLASS	F

REDUCER SPECIFICATION

TYPE	GTR
FORM	45
RATIO	1/5 1/7.5 1/10 1/12.5
LUBRICATION	1/15 1/20 1/25 1/30 GREASE

TITLE		F3S45N5~30-MV9AEB4			
DRAWING NO.		F3S45N-MV9AEB4			
USER					
NOTICE					
APPROVE	Y.Ikeda	SCALE	1/6	UNIT in	DATE 2015.05.01
CHECK	M.Iijima				
DESIGN	Y.Miura				
NISSEI CORPORATION					