

REVISIONS

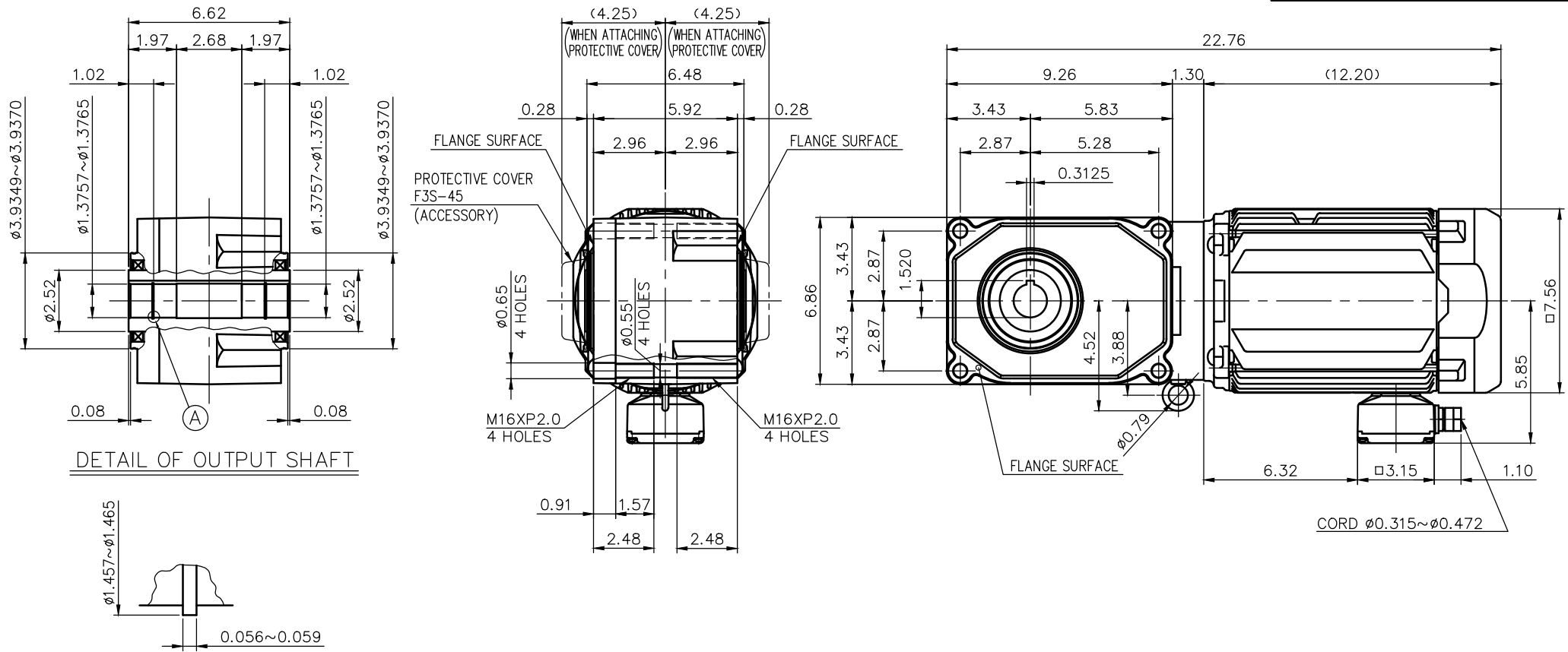

DETAIL OF OUTPUT SHAFT

DETAIL OF : A

NOTE: THE RATING OF ENCLOSURE CLASS:  
IP65 (EN60034-5) EQUIVALENT.  
NOTE: OUTPUT SHAFT MATERIAL: SUS420J2

NOTE: THIS MOTOR IS AFFIXED WITH CE MARKING.  
NOTE: THE GROUND LEAD SHOULD BE LONGER THAN  
THE SUPPLY LEAD FOR THE MOTOR.  
NOTE: THIS MOTOR IS UL CERTIFIED MODEL. (UL1004-1)  
NOTE: UL-LISTED MODEL NAME: WV9AEN

MOTOR SPECIFICATION

TYPE	3-PHASE INDUCTION MOTOR
FORM	TOTALLY ENCLOSED FAN COOLED P9
OUT PUT	3 HP
VOLTAGE	208/230/460/400 V
FREQ.	60/60/60/50 Hz
POLES	4
ROTATIONAL FREQUENCY	1800/1800/1800/1500 rpm
EFFICIENCY CLASS	IE3 EN60034-30 Standard
RATING	S1 CONT.
INS.CLASS	F

REDUCER SPECIFICATION

TYPE	GTR
FORM	45
RATIO	1/5 1/7.5 1/10 1/12.5 1/15 1/20 1/25 1/30
LUBRICATION	GREASE

TITLE		F3S45S5~30-WV9AEN DIMENSION OF MODEL			
DRAWING NO.		F3S45S-WV9AEN			
USER					
NOTICE					
APPROVE	Y.Ikeda	SCALE	1/6	UNIT in	DATE 2015.05.01
CHECK	M.Iijima				
DESIGN	Y.Miura				
NISSEI CORPORATION					