

REVISIONS

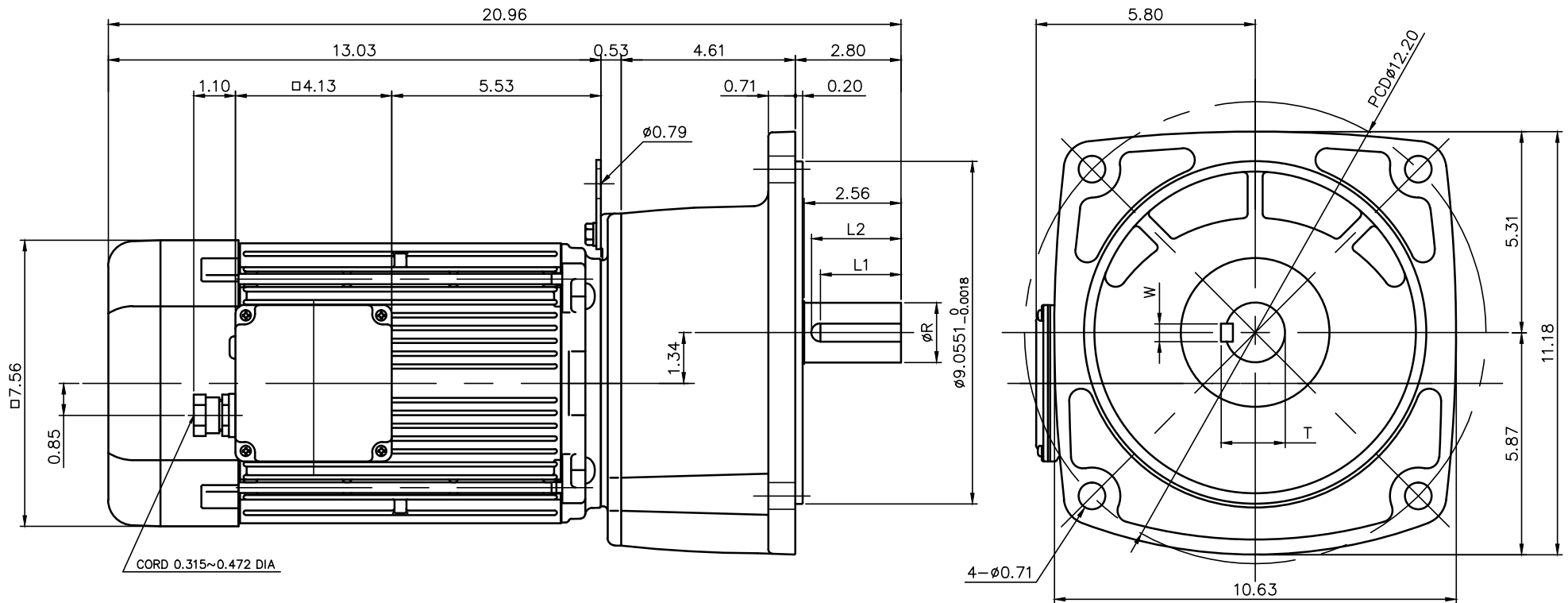

モータ仕様 MOTOR SPECIFICATION	
名称 TYPE	三相誘導電動機 THREE PHASE INDUCTION MOTOR
冷却方式 COOLING METHOD	全閉外扇形 TOTALLY ENCLOSED FAN COOLED
出力 MOTOR POWER	3 HP (2.2 kW)
定格 RATING	S1 CONT.
耐熱劣化 INS. CLASS	F
保護構造 IP RATING	IP 44
電磁ブレーキ仕様 BRAKE SPECIFICATION	
型式 MODEL	220_B2
方式 BRAKE TYPE	無励磁作動形 (スプリングクローズ) POWER-OFF (SPRING CLOSE)
励磁電圧 INPUT VOLTAGE	DC90V
容量 POWER CONSUMPTION	25W (AT 75°C)
静摩擦トルク STATIC FRICTION TORQUE	191 in-lb
動摩擦トルク DYNAMIC FRICTION TORQUE	152 in-lb

モータ仕様 MOTOR SPECIFICATION						
**	電圧 VOLTAGE	周波数 FREQUENCY	回転速度 ROTATION SPEED	電流値 CURRENT VALUE	対応規格 COMPLIANT STANDARDS	高効率認証 EFFICIENCY STANDARDS
AV	208 V 230 V 460 V 400 V	60 Hz 60 Hz 60 Hz 50 Hz	1750 r/min 1770 r/min 1770 r/min 1470 r/min	8.3 A 7.9 A 4.0 A 4.5 A	UL/cUL/CE	< IE3 > USA/CANADA
MA	575 V	60 Hz	1760 r/min	3.3 A	UL/cUL	

減速機仕様 REDUCER SPECIFICATION		
名称 TYPE	GTR	
枠番 FRAME NO.	40	
減速比 RATIO	5 10 15 20 25	
潤滑 LUBRICATION	グリース GREASE	
塗装 PAINT COLOR	グレー (マンセル値 9B6/0.5) GREY (MANSEL CODE: 9B6/0.5)	

出力軸仕様 OUTPUT SHAFT SPECIFICATION							
FRAME NO	R	STANDARD /OPTION	DIAMETER TOLERANCE	L1	L2	T	W
40	1.6250 in 40 mm	STANDARD OPTION	+0.0/-0.0010 +0.0/-0.016	2.25 in 60 mm	2.44 in 60 mm	1.791 in 43 mm	0.3750 in 12 mm

- 製品型式「□□□」は減速比によって入る文字数が変わります。
Number of characters on product model「□□□」varies depending on the reduction ratio.
- 製品型式「**」には「AV」「MA」が入ります
Replace product model「**」with「AV」「MA」.

TITLE	G3F40N□□□-MB22T**EB2 外形寸法図 DIMENSION OF MODEL				
DRAWING NO.	G3F40N-MB22TEB2				
USER					
NOTICE					
APPROVE	H.Hayashi	SCALE	1:4	UNIT	in
CHECK	M.Iijima			DATE	2020.03.31
DESIGN	A.Kobayashi	NISSEI CORPORATION			