

REVISIONS

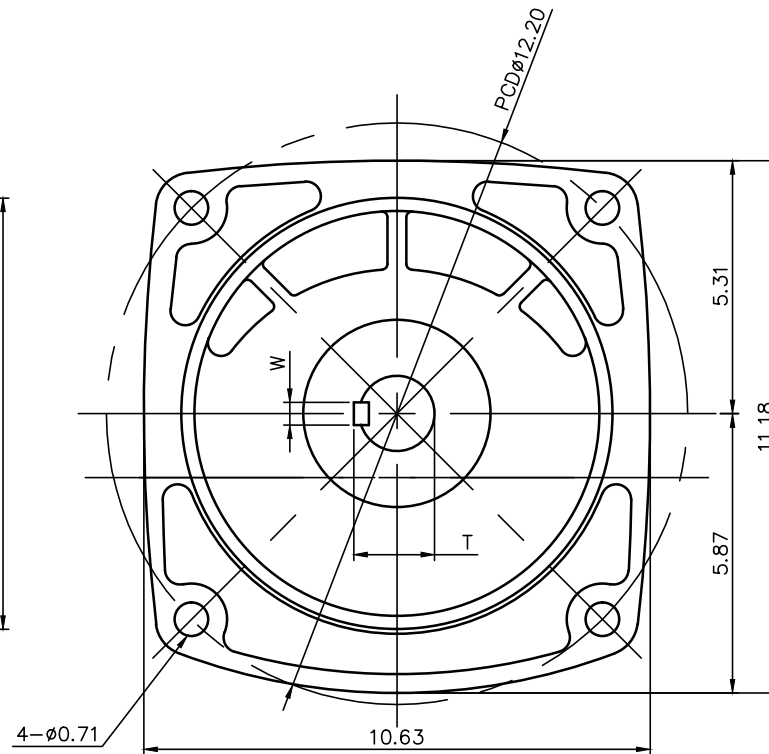
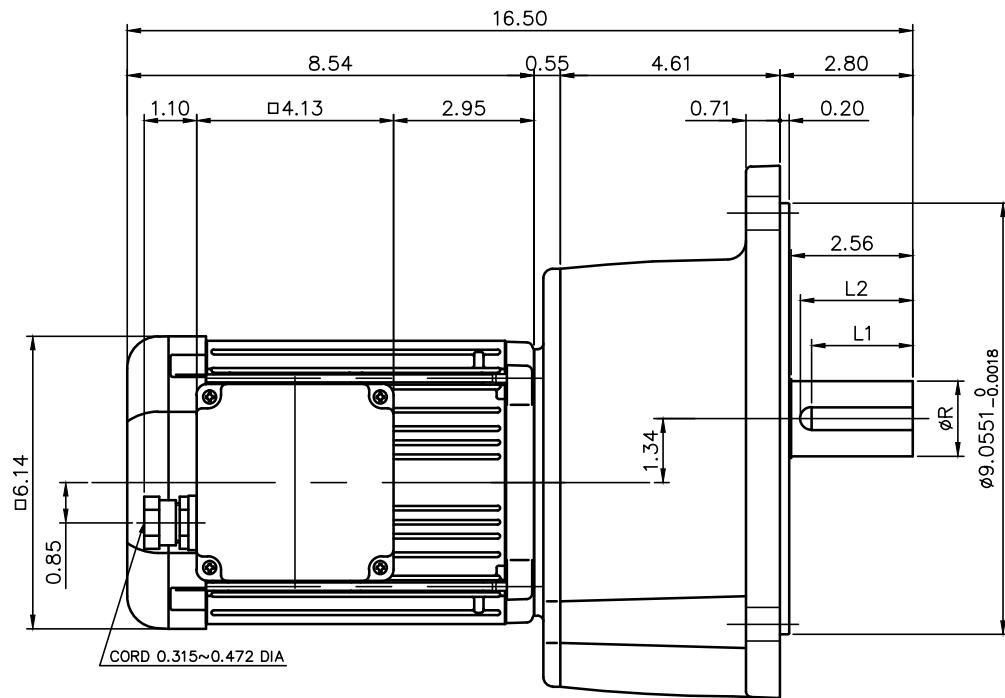

モータ仕様 MOTOR SPECIFICATION	
名称 TYPE	三相誘導電動機 THREE PHASE INDUCTION MOTOR
冷却方式 COOLING METHOD	全閉外扇形 TOTALLY ENCLOSED FAN COOLED
出力 MOTOR POWER	1 HP (0.75 kW)
定格 RATING	S1 CONT.
耐熱劣化 INS. CLASS	F
保護構造 IP RATING	IP65

モータ仕様 MOTOR SPECIFICATION						
**	電圧 VOLTAGE	周波数 FREQUENCY	回転速度 ROTATION SPEED	電流値 CURRENT VALUE	対応規格 COMPLIANT STANDARDS	高効率認証 EFFICIENCY STANDARDS
AV	208 V	60 Hz	1740 r/min	2.9 A	UL/cUL/CE	< IE3 > USA/CANADA
	230 V	60 Hz	1750 r/min	2.8 A		
	460 V	60 Hz	1750 r/min	1.4 A		
	400 V	50 Hz	1440 r/min	1.6 A		
EV	415 V	50 Hz	1440 r/min	1.50 A	UL/cUL	
	440 V	50 Hz	1450 r/min	1.50 A		
	480 V	60 Hz	1750 r/min	1.35 A		
MA	575 V	60 Hz	1750 r/min	1.10 A	UL/cUL	

減速機仕様 REDUCER SPECIFICATION		
名称 TYPE	GTR	
枠番 FRAME NO.	40	
減速比 RATIO	100 120 160 200	
潤滑 LUBRICATION	グリース GREASE	
塗装 PAINT COLOR	グレー (マンセル値 9B6/0.5) GREY (MANSEL CODE: 9B6/0.5)	

出力軸仕様 OUTPUT SHAFT SPECIFICATION							
FRAME NO	R	STANDARD /OPTION	DIAMETER TOLERANCE	L1	L2	T	W
40	1.6250 in 40 mm	STANDARD	+0.0/-0.0010	2.25 in 54 mm	2.44 in 60 mm	1.791 in 43 mm	0.3750 in 12 mm
		OPTION	+0.0/-0.016				

- 製品型式「□□□」は減速比によって入る文字数が変わります。  
Number of characters on product model「□□□」, varies depending on the reduction ratio.
- 製品型式「\*\*」には「AV」「EV」「MA」が入ります  
Replace product model「\*\*」with 「AV」「EV」「MA」.
- 出力軸・キーの材質は SUS420J2 を使用しています。  
THE MATERIAL OF THE OUTPUT SHAFT AND KEY IS SUS420J2.

TITLE		G3F40S□□□-WB08T**EN 外形寸法図 DIMENSION OF MODEL			
DRAWING NO.		G3F40S-WB08TEN			
USER					
NOTICE					
APPROVE	H.Hayashi	SCALE	1:4	UNIT in	DATE 2020.03.31
CHECK	M.Iijima				
DESIGN	A.Kobayashi				
NISSEI CORPORATION					