

REVISIONS

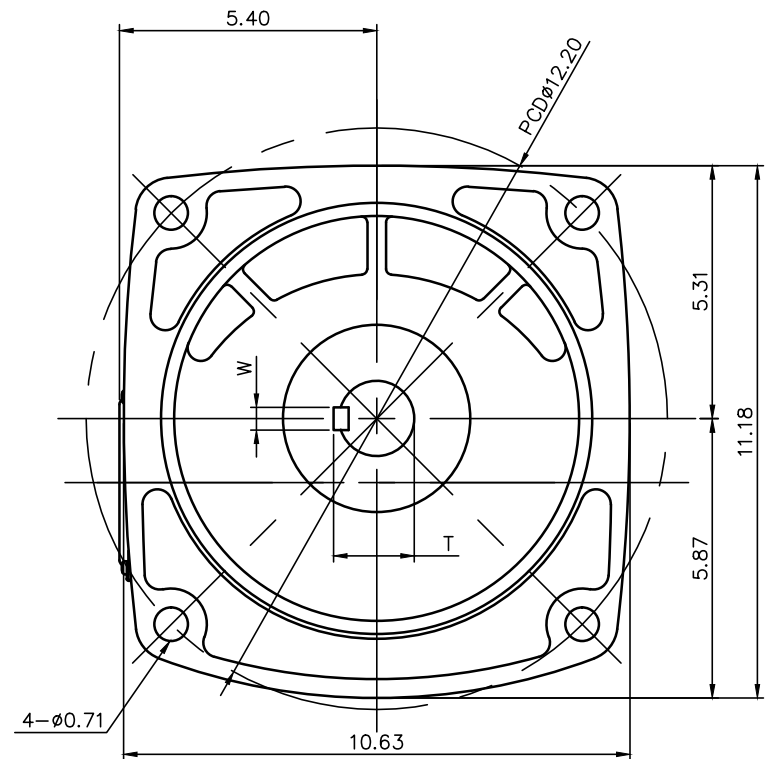
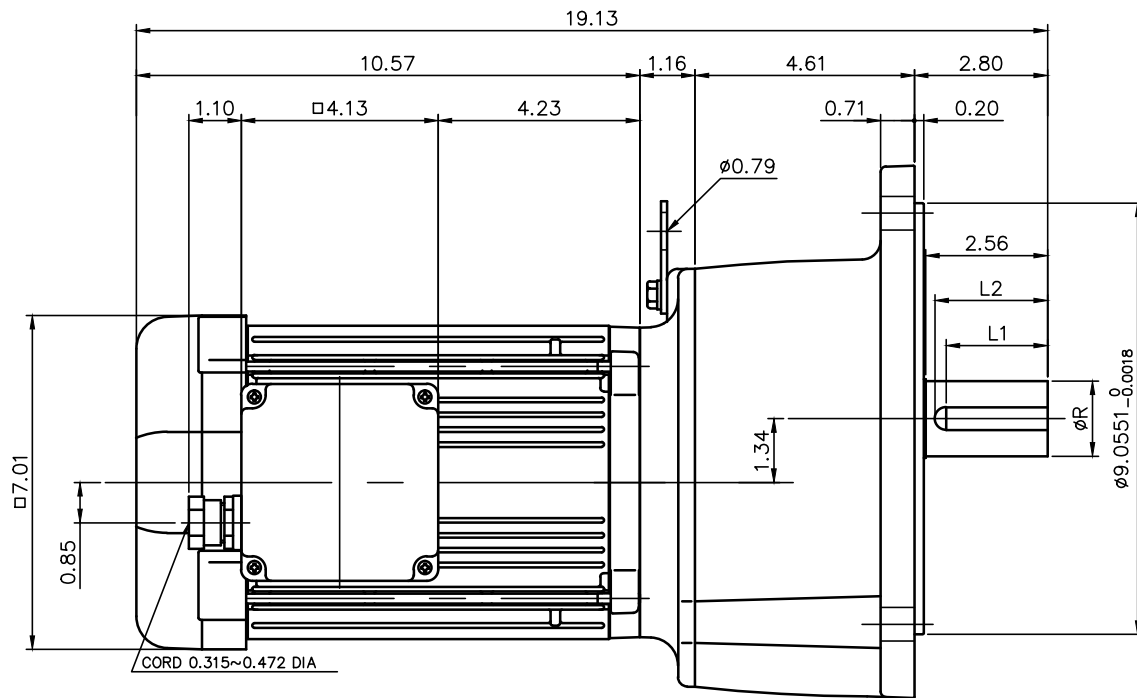

モータ仕様 MOTOR SPECIFICATION	
名称 TYPE	三相誘導電動機 THREE PHASE INDUCTION MOTOR
冷却方式 COOLING METHOD	全閉外扇形 TOTALLY ENCLOSED FAN COOLED
出力 MOTOR POWER	2 HP (1.5 kW)
定格 RATING	S1 CONT.
耐熱劣化 INS. CLASS	F
保護構造 IP RATING	IP65

モータ仕様 MOTOR SPECIFICATION						
**	電圧 VOLTAGE	周波数 FREQUENCY	回転速度 ROTATION SPEED	電流値 CURRENT VALUE	対応規格 COMPLIANT STANDARDS	高効率認証 EFFICIENCY STANDARDS
AV	208 V	60 Hz	1750 r/min	5.9 A	UL/cUL/CE	<IE3> USA/CANADA
	230 V	60 Hz	1760 r/min	5.7 A		
	460 V	60 Hz	1760 r/min	2.9 A		
	400 V	50 Hz	1450 r/min	3.2 A		
EV	415 V	50 Hz	1460 r/min	3.0 A	UL/cUL	
	440 V	50 Hz	1470 r/min	3.0 A		
	480 V	60 Hz	1760 r/min	2.7 A		
MA	575 V	60 Hz	1760 r/min	2.2 A	UL/cUL	

減速機仕様 REDUCER SPECIFICATION		
名称 TYPE	GTR	
枠番 FRAME NO.	40	
減速比 RATIO	30 40 50 60 80 100	
潤滑 LUBRICATION	グリース GREASE	
塗装 PAINT COLOR	グレー (マンセル値 9B6/0.5) GREY (MANSEL CODE: 9B6/0.5)	

出力軸仕様 OUTPUT SHAFT SPECIFICATION							
FRAME NO	R	STANDARD /OPTION	DIAMETER TOLERANCE	L1	L2	T	W
40	1.6250 in 40 mm	STANDARD OPTION	+0.0/-0.0010 +0.0/-0.016	2.25 in 54 mm	2.44 in 60 mm	1.791 in 43 mm	0.3750 in 12 mm

- 製品型式「□□□」は減速比によって入る文字数が変わります。
Number of characters on product model「□□□」varies depending on the reduction ratio.
- 製品型式「**」には「AV」「EV」「MA」が入ります
Replace product model「**」with「AV」「EV」「MA」.
- 出力軸・キーの材質は SUS420J2 を使用しています。
THE MATERIAL OF THE OUTPUT SHAFT AND KEY IS SUS420J2.

TITLE		G3F40S□□□-WB15T**EN			
		外形寸法図 DIMENSION OF MODEL			
DRAWING NO.		G3F40S-WB15TEN			
USER					
NOTICE					
APPROVE	H.Hayashi	SCALE	1:4	UNIT	DATE
CHECK	M.Iijima				
DESIGN	A.Kobayashi				
				in	2020.03.31
NISSEI CORPORATION					