

REVISIONS

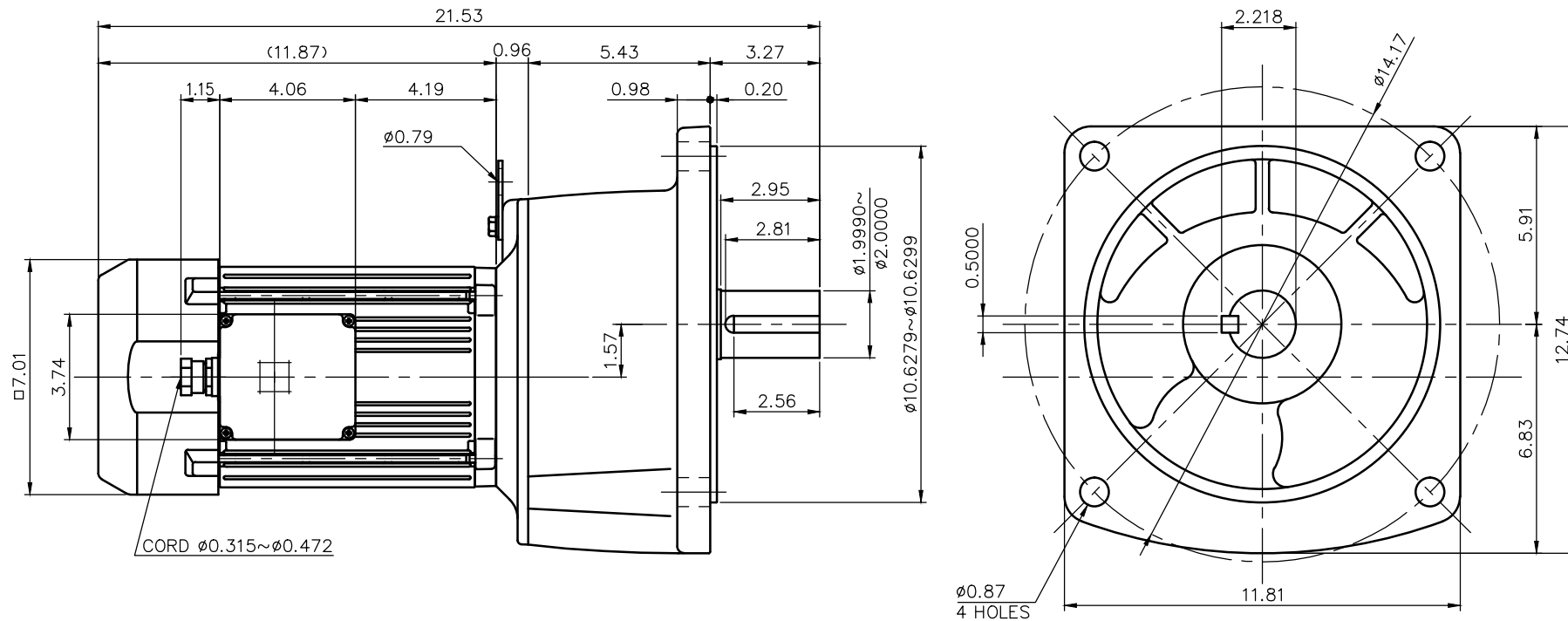

NOTE: THE BRAKE LEADS ARE PULLED INTO THE TERMINAL BOX.  
 NOTE: THE ATTACHED RECTIFIER IS USED FOR DC POWER SUPPLY TO THE BRAKE COIL.

NOTE: COMPLIANCE CERTIFICATION NUMBER: CC303B  
 NOTE: THIS MOTOR IS AFFIXED WITH CE MARKING.  
 NOTE: THE GROUND LEAD SHOULD BE LONGER THAN THE SUPPLY LEAD FOR THE MOTOR.  
 NOTE: THIS MOTOR IS UL CERTIFIED MODEL. (UL1004-1)  
 NOTE: UL-LISTED MODEL NAME: MV8AWB2

BRAKE SPECIFICATION

|                   |                 |
|-------------------|-----------------|
| TYPE              | BS3-15IP        |
| BRAKE TYPE        | SPRING CLOSE    |
| INPUT VOLTAGE     | DC 104V         |
| POWER CONSUMPTION | 44 W (at 75 °C) |
| BRAKE TORQUE      | 104.1 in-lbs    |

MOTOR SPECIFICATION

|                      |                                |
|----------------------|--------------------------------|
| TYPE                 | 3-PHASE INDUCTION MOTOR        |
| FORM                 | TOTALLY ENCLOSED FAN COOLED P8 |
| OUT PUT              | 2 HP                           |
| VOLTAGE              | 208/230/460/400 V              |
| FREQ.                | 60/60/60/50 Hz                 |
| POLES                | 4                              |
| ROTATIONAL FREQUENCY | 1800/1800/1800/1500 rpm        |
| EFFICIENCY CLASS     | IE3 EN60034-30 Standard        |
| RATING               | S1 CONT.                       |
| INS.CLASS            | F                              |

REDUCER SPECIFICATION

|             |                   |
|-------------|-------------------|
| TYPE        | GTR               |
| FORM        | 50                |
| RATIO       | 1/100 1/120 1/160 |
| LUBRICATION | GREASE            |

|   |          |                |     |         |                 |
|---|----------|----------------|-----|---------|-----------------|
| TITLE G3F50N100~200-MV8AWB2<br>DIMENSION OF MODEL |          |                |     |         |                 |
| DRAWING NO.                                       |          | G3F50N-MV8AWB2 |     |         |                 |
| USER  |          |                |     |         |                 |
| NOTICE  |          |                |     |         |                 |
| APPROVE   | Y.Ikeda  | SCALE          | 1/5 | UNIT in | DATE 2016.04.01 |
| CHECK   | M.Iijima |                |     |         |                 |
| DESIGN  | Y.Miura  |                |     |         |                 |
| NISSEI CORPORATION                                |          |                |     |         |                 |