

REVISIONS

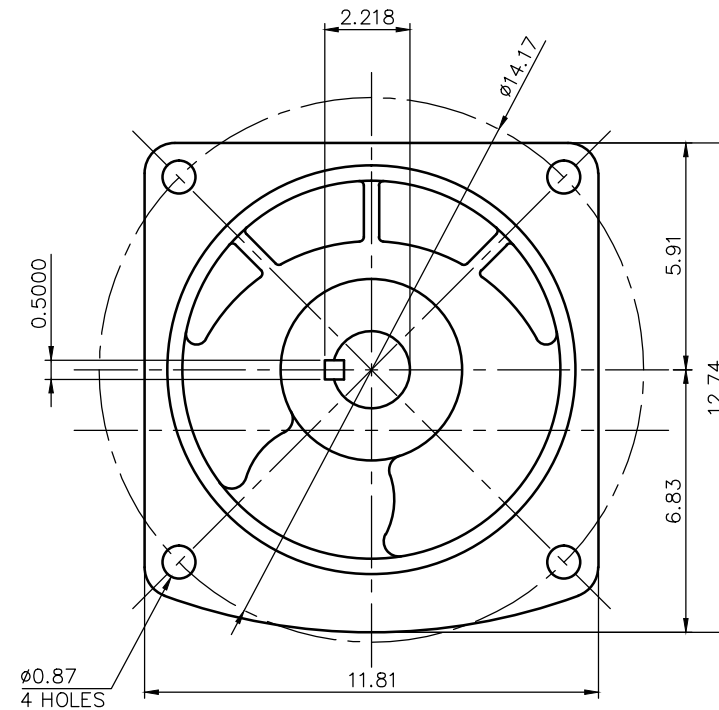
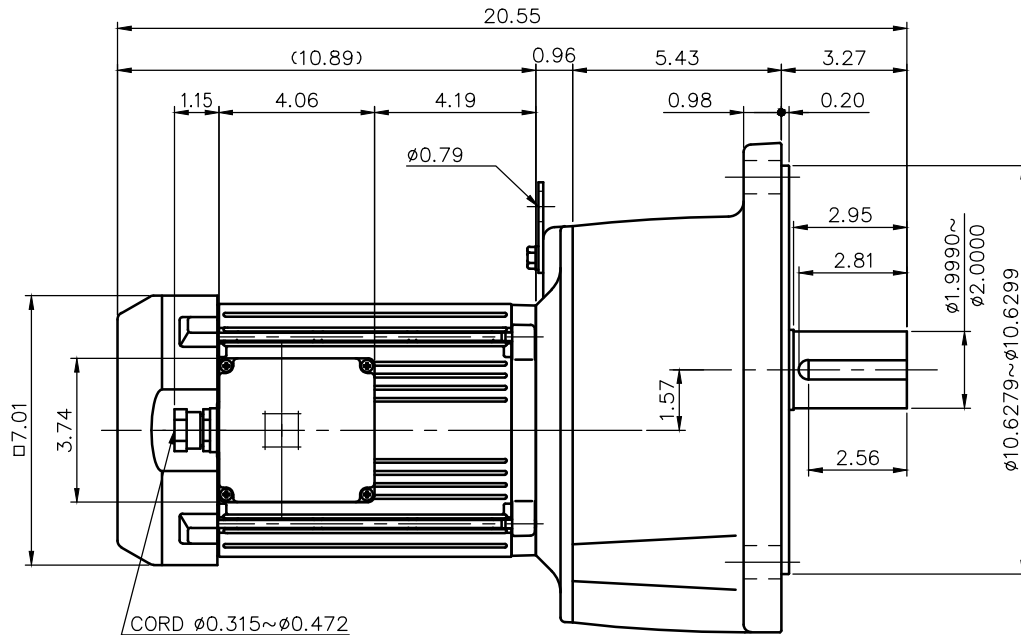

MOTOR SPECIFICATION

TYPE	3-PHASE INDUCTION MOTOR
FORM	TOTALLY ENCLOSED FAN COOLED P8
OUT PUT	2 HP
VOLTAGE	208/230/460/400 V
FREQ.	60/60/60/50 Hz
POLES	4
ROTATIONAL FREQUENCY	1800/1800/1800/1500 rpm
EFFICIENCY CLASS	IE3 EN60034-30 Standard
RATING	S1 CONT.
INS.CLASS	F

REDUCER SPECIFICATION

TYPE	GTR
FORM	50
RATIO	1/100 1/120 1/160
LUBRICATION	GREASE

NOTE: COMPLIANCE CERTIFICATION NUMBER: CC303B
 NOTE: THIS MOTOR IS AFFIXED WITH CE MARKING.
 NOTE: THE GROUND LEAD SHOULD BE LONGER THAN THE SUPPLY LEAD FOR THE MOTOR.
 NOTE: THIS MOTOR IS UL CERTIFIED MODEL. (UL1004-1)
 NOTE: UL-LISTED MODEL NAME: MV8AWN

TITLE		G3F50N100~200-MV8AWN			
DRAWING NO.		G3F50N-MV8AWN			
USER					
NOTICE					
APPROVE	Y.Ikeda	SCALE	1/5	UNIT in	DATE 2016.04.01
CHECK	M.Iijima				
DESIGN	Y.Miura				
NISSEI CORPORATION					