

REVISIONS

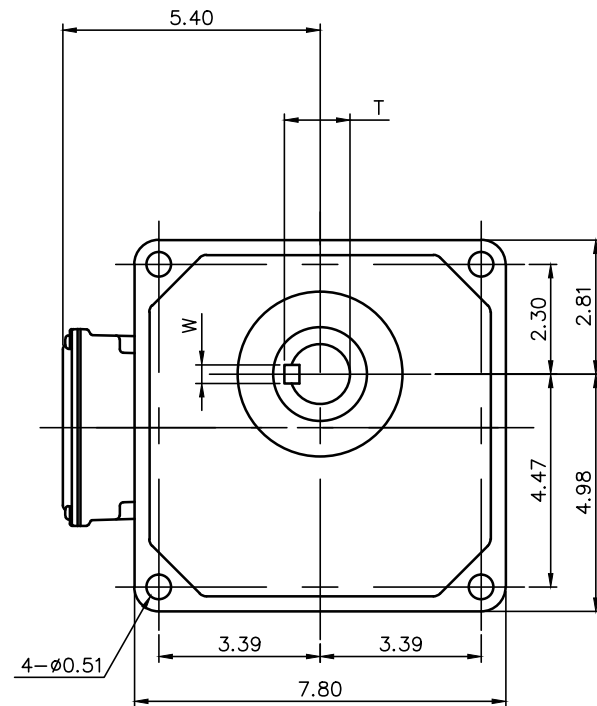
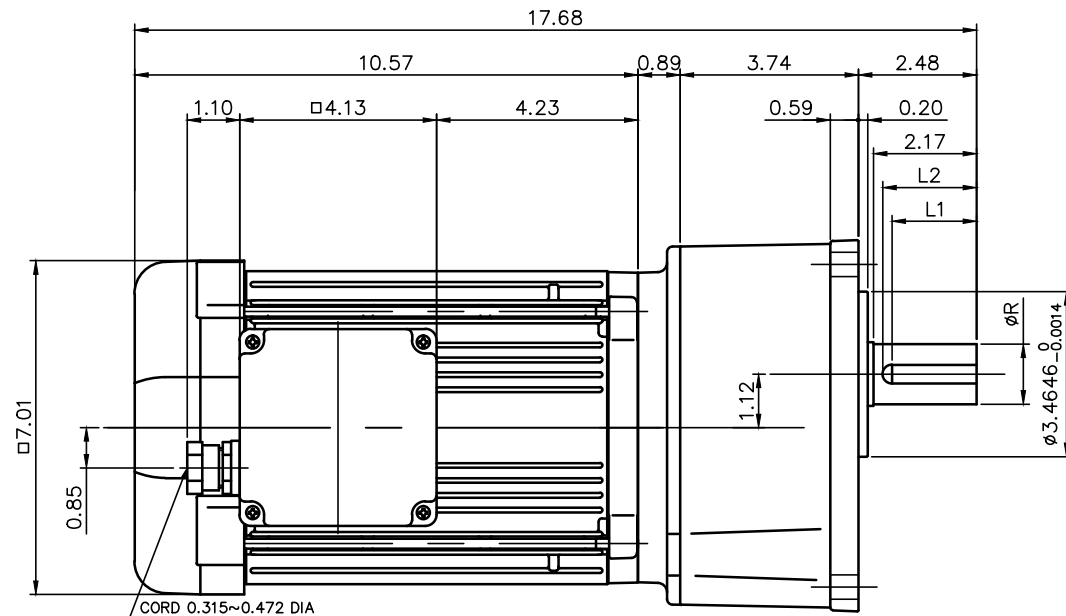

モータ仕様 MOTOR SPECIFICATION	
名称 TYPE	三相誘導電動機 THREE PHASE INDUCTION MOTOR
冷却方式 COOLING METHOD	全閉外扇形 TOTALLY ENCLOSED FAN COOLED
出力 MOTOR POWER	2 HP (1.5 kW)
定格 RATING	S1 CONT.
耐熱劣化 INS. CLASS	F
保護構造 IP RATING	IP44

モータ仕様 MOTOR SPECIFICATION						
**	電圧 VOLTAGE	周波数 FREQUENCY	回転速度 ROTATION SPEED	電流値 CURRENT VALUE	対応規格 COMPLIANT STANDARDS	高効率認証 EFFICIENCY STANDARDS
AV	208 V	60 Hz	1750 r/min	5.9 A	UL/cUL/CE	<IE3> USA/CANADA
	230 V	60 Hz	1760 r/min	5.7 A		
	460 V	60 Hz	1760 r/min	2.9 A		
	400 V	50 Hz	1450 r/min	3.2 A		
EV	415 V	50 Hz	1460 r/min	3.0 A	UL/cUL	
	440 V	50 Hz	1470 r/min	3.0 A		
	480 V	60 Hz	1760 r/min	2.7 A		
MA	575 V	60 Hz	1760 r/min	2.2 A	UL/cUL	

減速機仕様 REDUCER SPECIFICATION		
名称 TYPE	GTR	
枠番 FRAME NO.	32	
減速比 RATIO	5 10 15 20 25	
潤滑 LUBRICATION	グリース GREASE	
塗装 PAINT COLOR	グレー (マンセル値 9B6/0.5) GREY (MANSEL CODE: 9B6/0.5)	

出力軸仕様 OUTPUT SHAFT SPECIFICATION							
FRAME NO.	R	STANDARD / OPTION	DIAMETER TOLERANCE	L1	L2	T	W
32	1.2500 in 32 mm	STANDARD OPTION	+0.0/-0.0005 +0.0/-0.016	1.88 in 50 mm	2.00 in 50 mm	1.362 in 35 mm	0.2500 in 10 mm

- 製品型式「□□□」は減速比によって入る文字数が変わります。
Number of characters on product model「□□□」, varies depending on the reduction ratio.
- 製品型式「**」には「AV」「EV」「MA」が入ります
Replace product model「**」 with 「AV」「EV」「MA」.

TITLE	G3K32N□□□-MB15T**EN 外形寸法図 DIMENSION OF MODEL				
DRAWING NO.	G3K32N-MB15TEN				
USER					
NOTICE					
APPROVE	H.Hayashi	SCALE	1:4	UNIT	in
CHECK	M.Iijima	DATE	2020.03.31		
DESIGN	A.Kobayashi	NISSEI CORPORATION			