

REVISIONS

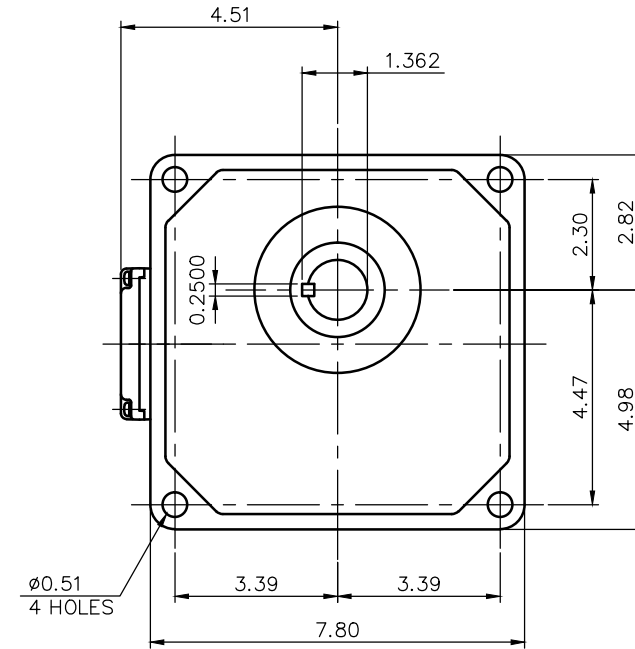
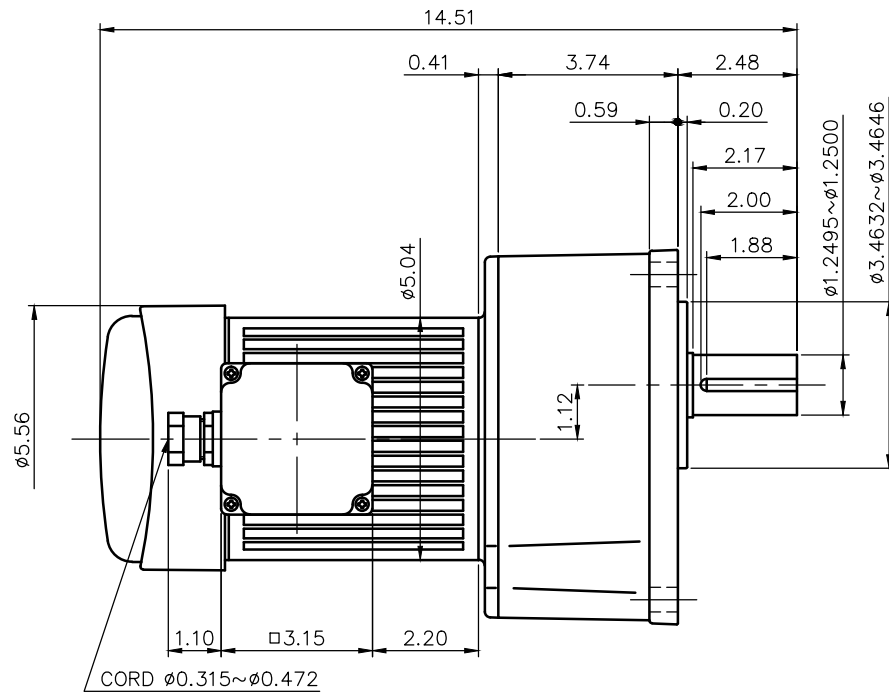

NOTE: THE ATTACHED RECTIFIER IS USED FOR DC POWER SUPPLY TO THE BRAKE COIL.

NOTE: THE BRAKE LEADS ARE PULLED INTO THE TERMINAL BOX.  
 NOTE: THIS MOTOR IS AFFIXED WITH CE MARKING.  
 NOTE: THE GROUND LEAD SHOULD BE LONGER THAN THE SUPPLY LEAD FOR THE MOTOR.  
 NOTE: THIS MOTOR IS UL CERTIFIED MODEL.(UL1004-1)  
 NOTE: UL-LISTED MODEL NAME: MF4AEB4

BRAKE SPECIFICATION

TYPE	BS3-04-180
BRAKE TYPE	SPRING CLOSE
INPUT VOLTAGE	DC 207V
POWER CONSUMPTION	22 W (at 75°C)
BRAKE TORQUE	27.8 in-lbs

MOTOR SPECIFICATION

TYPE	3-PHASE INDUCTION MOTOR
FORM	TOTALLY ENCLOSED FAN COOLED
OUT PUT	1/2 HP
VOLTAGE	208/230/460/400 V
FREQ.	60/60/60/50 Hz
POLES	4
ROTATIONAL FREQUENCY	1800/1800/1800/1500 rpm
RATING	S1 CONT.
INS.CLASS	F

REDUCER SPECIFICATION

TYPE	GTR
FORM	32
RATIO	1/100 1/120 1/160
LUBRICATION	GREASE

TITLE G3K32N100~200-MF4AEB4  
 DIMENSION OF MODEL

DRAWING NO. G3K32N-MF4AEB4

USER

NOTICE

APPROVE	Y.Ikeda	SCALE	1/4		UNIT	DATE
CHECK	M.Iijima				in	2015.07.15
DESIGN	Y.Miura				NISSEI CORPORATION	