

REVISIONS

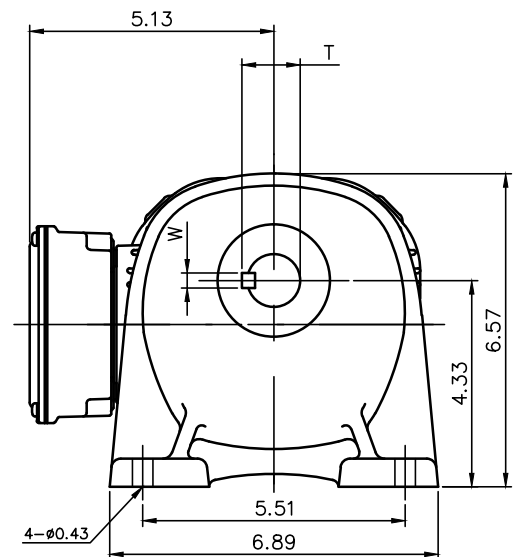
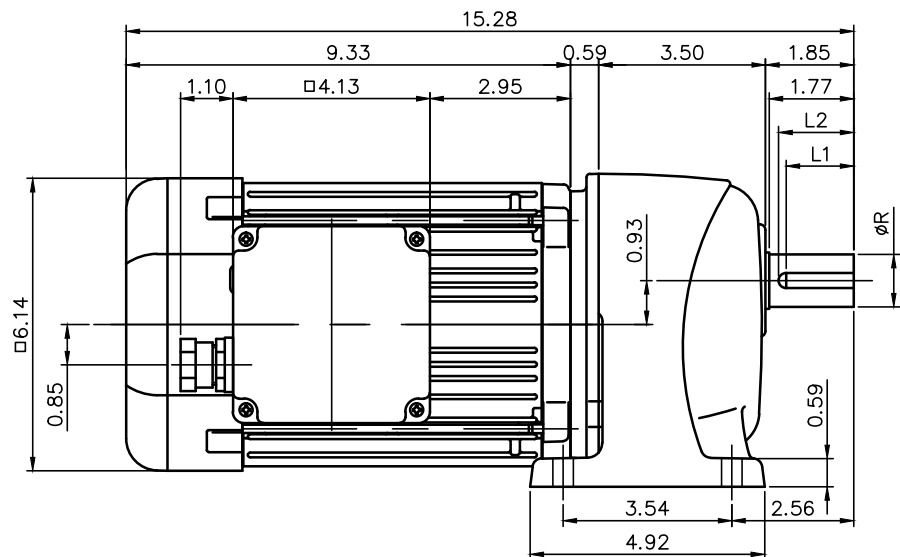

モータ仕様 MOTOR SPECIFICATION	
名称 TYPE	三相誘導電動機 THREE PHASE INDUCTION MOTOR
冷却方式 COOLING METHOD	全閉外扇形 TOTALLY ENCLOSED FAN COOLED
出力 MOTOR POWER	1 HP (0.75 kW)
定格 RATING	S1 CONT.
耐熱劣化 INS. CLASS	F
保護構造 IP RATING	IP44
電磁ブレーキ仕様 BRAKE SPECIFICATION	
型式 MODEL	075_B4
方式 BRAKE TYPE	無励磁作動形 (スプリングクローズ) POWER-OFF (SPRING CLOSE)
励磁電圧 INPUT VOLTAGE	DC180V
容量 POWER CONSUMPTION	20W (AT 75°C)
静摩擦トルク STATIC FRICTION TORQUE	65 in-lb
動摩擦トルク DYNAMIC FRICTION TORQUE	52 in-lb

モータ仕様 MOTOR SPECIFICATION						
**	電圧 VOLTAGE	周波数 FREQUENCY	回転速度 ROTATION SPEED	電流値 CURRENT VALUE	対応規格 COMPLIANT STANDARDS	高効率認証 EFFICIENCY STANDARDS
AV	208 V	60 Hz	1740 r/min	2.9 A	UL/cUL/CE	<IE3>
	230 V	60 Hz	1750 r/min	2.8 A		
	460 V	60 Hz	1750 r/min	1.4 A		
	400 V	50 Hz	1440 r/min	1.6 A		
EV	415 V	50 Hz	1440 r/min	1.50 A		
	440 V	50 Hz	1450 r/min	1.50 A		
	480 V	60 Hz	1750 r/min	1.35 A		

減速機仕様 REDUCER SPECIFICATION		
名称 TYPE	GTR	
枠番 FRAME NO.	28	
減速比 RATIO	5 10 15 20 25	
潤滑 LUBRICATION	グリース GREASE	
塗装 PAINT COLOR	グレー (マンセル値 9B6/0.5) GREY (MANSEL CODE: 9B6/0.5)	

出力軸仕様 OUTPUT SHAFT SPECIFICATION							
FRAME NO	R	STANDARD /OPTION	DIAMETER TOLERANCE	L1	L2	T	W
28	1.1250 in 28 mm	STANDARD OPTION	+0.0/-0.0005 +0.0/-0.013	1.50 in 40 mm	1.63 in 40 mm	1.236 in 31 mm	0.2500 in 8 mm

- 製品型式「□□□」は減速比によって入る文字数が変わります。  
Number of characters on product model「□□□」, varies depending on the reduction ratio.
- 製品型式「\*\*」には「AV」「EV」が入ります。  
Replace product model「\*\*」 with 「AV」「EV」.

TITLE	G3L28N□□□-MB08T* *EB4 外形寸法図 DIMENSION OF MODEL				
DRAWING NO.	G3L28N-MB08TEB4				
USER					
NOTICE					
APPROVE	H.Hayashi	SCALE	1:4	UNIT	in
CHECK	M.Iijima			DATE	2020.03.31
DESIGN	A.Kobayashi	NISSEI CORPORATION			