

REVISIONS

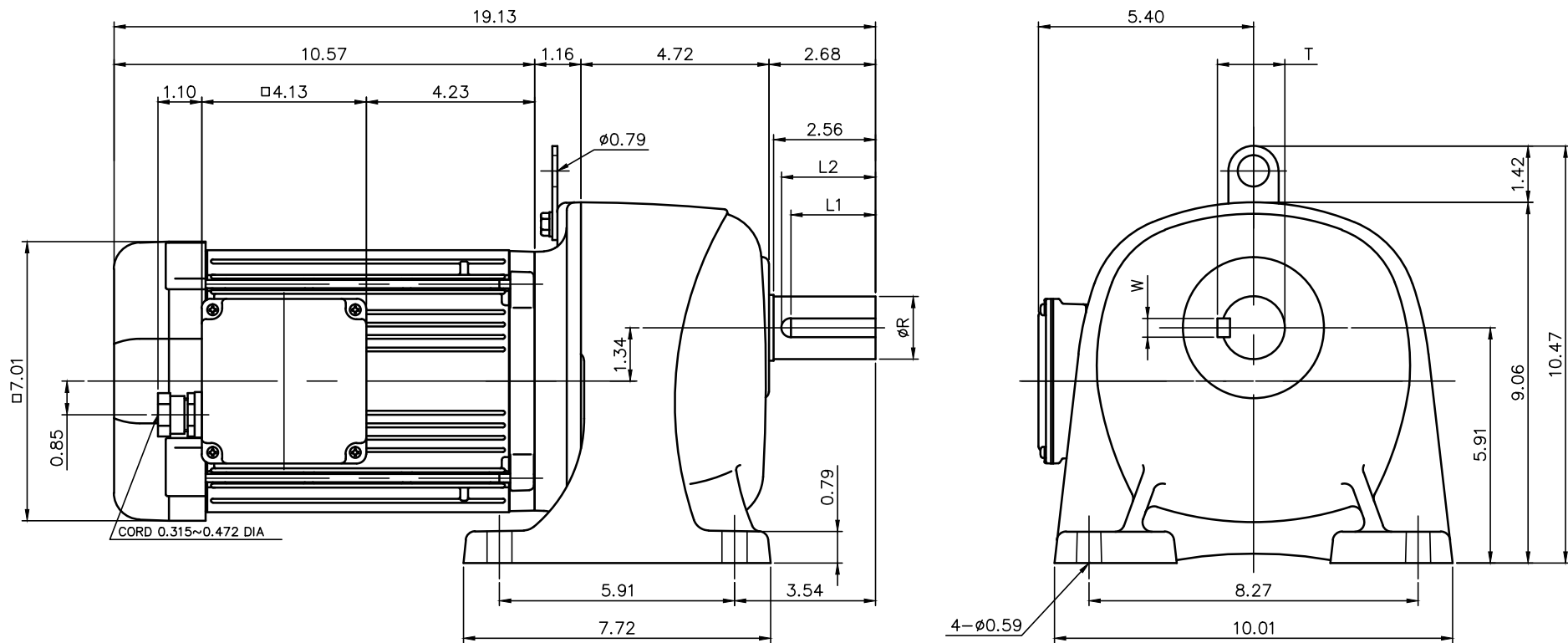

| モータ仕様 MOTOR SPECIFICATION | |
|---------------------------|--|
| 名称 TYPE | 三相誘導電動機 THREE PHASE INDUCTION MOTOR |
| 冷却方式 COOLING METHOD | 全閉外扇形 TOTALLY ENCLOSED FAN COOLED |
| 出力 MOTOR POWER | 2 HP (1.5 kW) |
| 定格 RATING | S1 CONT. |
| 耐熱劣化 INS. CLASS | F |
| 保護構造 IP RATING | IP65 |

| モータ仕様 MOTOR SPECIFICATION | | | | | | |
|---------------------------|----------------------------------|----------------------------------|--|----------------------------------|--------------------------|----------------------------|
| ** | 電圧 VOLTAGE | 周波数 FREQUENCY | 回転速度 ROTATION SPEED | 電流値 CURRENT VALUE | 対応規格 COMPLIANT STANDARDS | 高効率認証 EFFICIENCY STANDARDS |
| AV | 208 V 230 V 460 V 400 V | 60 Hz 60 Hz 60 Hz 50 Hz | 1750 r/min 1760 r/min 1760 r/min 1450 r/min | 5.9 A 5.7 A 2.9 A 3.2 A | UL/cUL/CE | < IE3 > USA/CANADA |
| EV | 415 V 440 V 480 V | 50 Hz 50 Hz 60 Hz | 1460 r/min 1470 r/min 1760 r/min | 3.0 A 3.0 A 2.7 A | | |
| MA | 575 V | 60 Hz | 1760 r/min | 2.2 A | UL/cUL | |

| 減速機仕様 REDUCER SPECIFICATION | | |
|-----------------------------|--|--|
| 名称 TYPE | GTR | |
| 枠番 FRAME NO. | 40 | |
| 減速比 RATIO | 30 40 50 60 80 100 | |
| 潤滑 LUBRICATION | グリース GREASE | |
| 塗装 PAINT COLOR | グレー (マンセル値 9B6/0.5) GREY (MANSEL CODE: 9B6/0.5) | |

| 出力軸仕様 OUTPUT SHAFT SPECIFICATION | | | | | | | |
|----------------------------------|--------------------|--------------------|-----------------------------|------------------|------------------|-------------------|--------------------|
| FRAME NO | R | STANDARD /OPTION | DIAMETER TOLERANCE | L1 | L2 | T | W |
| 40 | 1.6250 in 40 mm | STANDARD OPTION | +0.0/-0.0010 +0.0/-0.016 | 2.25 in 54 mm | 2.44 in 60 mm | 1.791 in 43 mm | 0.3750 in 12 mm |

- 製品型式「□□□」は減速比によって入る文字数が変わります。
Number of characters on product model「□□□」varies depending on the reduction ratio.
- 製品型式「**」には「AV」「EV」「MA」が入ります
Replace product model「**」with「AV」「EV」「MA」.
- 出力軸・キーの材質は SUS420J2 を使用しています。
THE MATERIAL OF THE OUTPUT SHAFT AND KEY IS SUS420J2.

| | | | | | |
|-------------|---|--------------------|-----|------|------------|
| TITLE | G3L40S□□□-WB15T**EN 外形寸法図 DIMENSION OF MODEL | | | | |
| DRAWING NO. | G3L40S-WB15TEN | | | | |
| USER | | | | | |
| NOTICE | | | | | |
| APPROVE | H.Hayashi | SCALE | 1:4 | UNIT | in |
| CHECK | M.Iijima | | | DATE | 2020.03.31 |
| DESIGN | A.Kobayashi | NISSEI CORPORATION | | | |