

REVISIONS

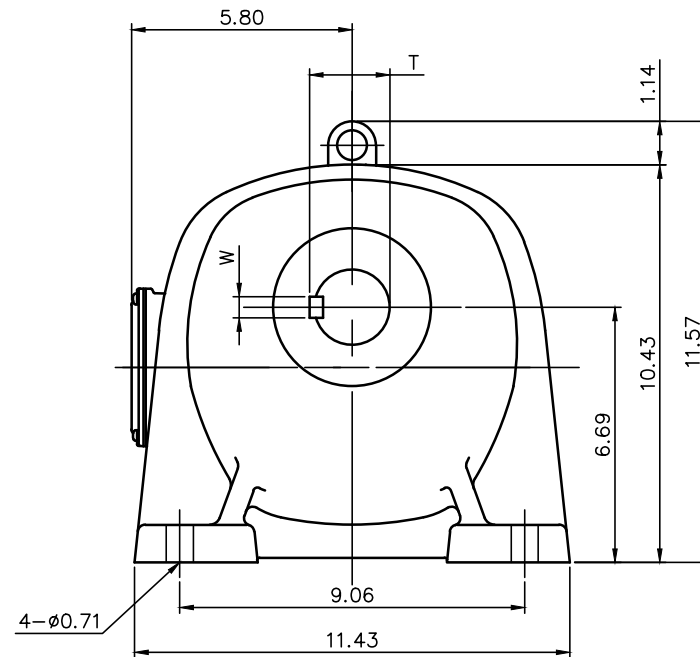
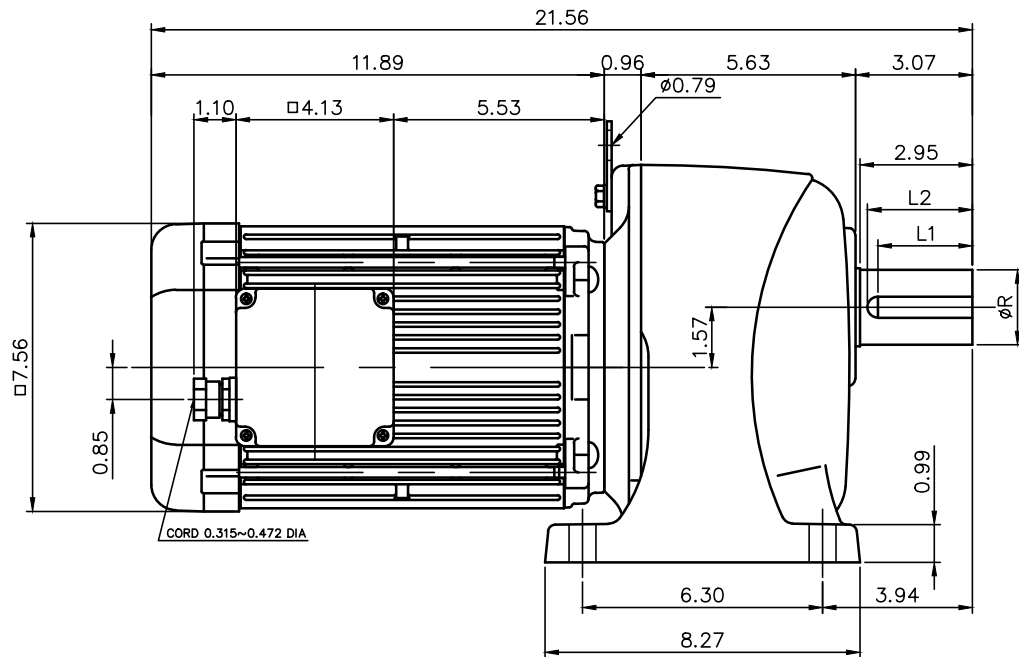

モータ仕様 MOTOR SPECIFICATION	
名称 TYPE	三相誘導電動機 THREE PHASE INDUCTION MOTOR
冷却方式 COOLING METHOD	全閉外扇形 TOTALLY ENCLOSED FAN COOLED
出力 MOTOR POWER	3 HP (2.2 kW)
定格 RATING	S1 CONT.
耐熱劣化 INS. CLASS	F
保護構造 IP RATING	IP65

モータ仕様 MOTOR SPECIFICATION						
**	電圧 VOLTAGE	周波数 FREQUENCY	回転速度 ROTATION SPEED	電流値 CURRENT VALUE	対応規格 COMPLIANT STANDARDS	高効率認証 EFFICIENCY STANDARDS
AV	208 V	60 Hz	1750 r/min	8.3 A	UL/cUL/CE	<IE3> USA/CANADA
	230 V	60 Hz	1770 r/min	7.9 A		
	460 V	60 Hz	1770 r/min	4.0 A		
	400 V	50 Hz	1470 r/min	4.5 A		
EV	415 V	50 Hz	1460 r/min	4.3 A	UL/cUL	
	440 V	50 Hz	1470 r/min	4.3 A		
	480 V	60 Hz	1770 r/min	3.8 A		
MA	575 V	60 Hz	1760 r/min	3.3 A	UL/cUL	

減速機仕様 REDUCER SPECIFICATION		
名称 TYPE	GTR	
枠番 FRAME NO.	50	
減速比 RATIO	30 40 50 60 80 100	
潤滑 LUBRICATION	グリース GREASE	
塗装 PAINT COLOR	グレー (マンセル値 9B6/0.5) GREY (MANSEL CODE: 9B6/0.5)	

出力軸仕様 OUTPUT SHAFT SPECIFICATION							
FRAME NO	R	STANDARD /OPTION	DIAMETER TOLERANCE	L1	L2	T	W
50	2.0000 in	STANDARD	+0.0/-0.0010	2.56 in	2.81 in	2.218 in	0.5000 in
	50 mm	OPTION	+0.0/-0.016	63 mm	70 mm	53.5 mm	14 mm

- 製品型式「□□□」は減速比によって入る文字数が変わります。  
Number of characters on product model「□□□」varies depending on the reduction ratio.
- 製品型式「\*\*」には「AV」「EV」「MA」が入ります  
Replace product model「\*\*」with「AV」「EV」「MA」.
- 出力軸・キーの材質は SUS420J2 を使用しています。  
THE MATERIAL OF THE OUTPUT SHAFT AND KEY IS SUS420J2.

TITLE	G3L50S□□□-WB22T**EN 外形寸法図 DIMENSION OF MODEL				
DRAWING NO.	G3L50S-WB22TEN				
USER					
NOTICE					
APPROVE	H.Hayashi	SCALE	1:5	UNIT in	DATE 2020.03.31
CHECK	M.Iijima				
DESIGN	A.Kobayashi				