

REVISIONS

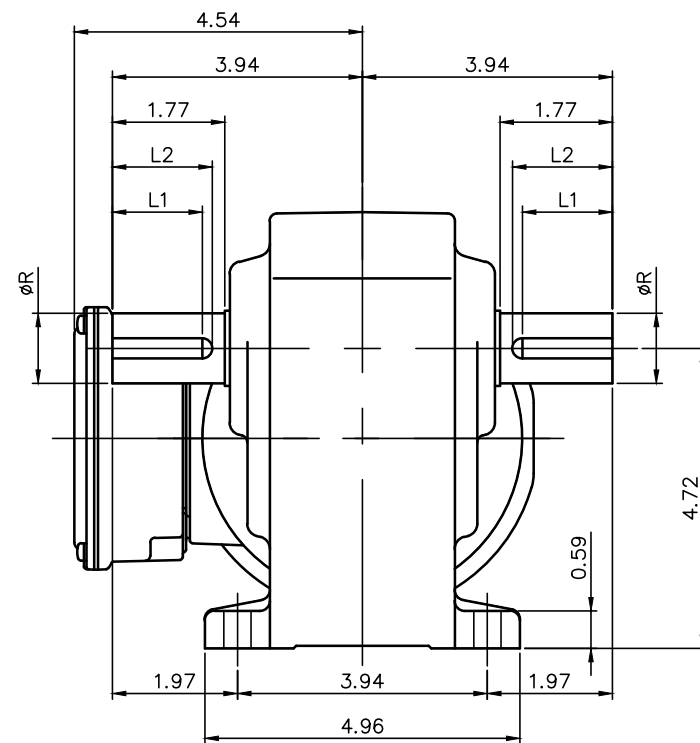
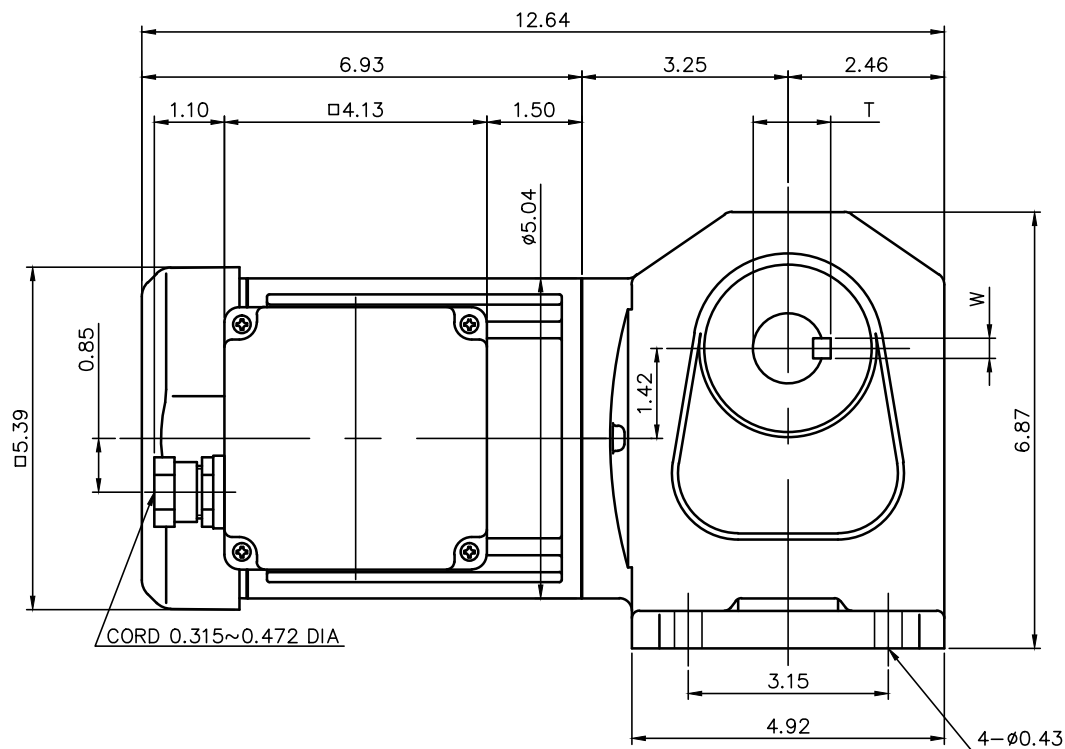

モータ仕様 MOTOR SPECIFICATION	
名称 TYPE	三相誘導電動機 THREE PHASE INDUCTION MOTOR
冷却方式 COOLING METHOD	全閉外扇形 TOTALLY ENCLOSED FAN COOLED
出力 MOTOR POWER	1/2 HP (0.4 kW)
定格 RATING	S1 CONT.
耐熱劣化 INS. CLASS	F
保護構造 IP RATING	IP65

モータ仕様 MOTOR SPECIFICATION						
**	電圧 VOLTAGE	周波数 FREQUENCY	回転速度 ROTATION SPEED	電流値 CURRENT VALUE	対応規格 COMPLIANT STANDARDS	高効率認証 EFFICIENCY STANDARDS
AV	208 V 230 V 460 V 400 V	60 Hz 60 Hz 60 Hz 50 Hz	1680 r/min 1720 r/min 1720 r/min 1400 r/min	1.8 A 1.8 A 0.9 A 1.0 A	UL/cUL/CE	-
EV	415 V 440 V 480 V	50 Hz 50 Hz 60 Hz	1390 r/min 1410 r/min 1680 r/min	0.96 A 0.95 A 0.82 A		
MA	575 V	60 Hz	1700 r/min	0.68 A	UL/cUL	

減速機仕様 REDUCER SPECIFICATION		
名称 TYPE	GTR	
枠番 FRAME NO.	28	
減速比 RATIO	5 10 15 20 25 30 40 50 60	
潤滑 LUBRICATION	グリース GREASE	
塗装 PAINT COLOR	グレー (マンセル値 9B6/0.5) GREY (MANSEL CODE: 9B6/0.5)	

出力軸仕様 OUTPUT SHAFT SPECIFICATION							
FRAME NO	R	STANDARD /OPTION	DIAMETER TOLERANCE	L1	L2	T	W
28	1.1250 in 28 mm	STANDARD OPTION	+0.0/-0.0005 +0.0/-0.013	1.50 in 36 mm	1.63 in 40 mm	1.236 in 31 mm	0.2500 in 8 mm

- 製品型式「□□□」は減速比によって入る文字数が変わります。
Number of characters on product model「□□□」varies depending on the reduction ratio.
- 製品型式「**」には「AV」「EV」「MA」が入ります。
Replace product model「**」with「AV」「EV」「MA」.
- 出力軸・キーの材質は SUS420J2 を使用しています。
THE MATERIAL OF THE OUTPUT SHAFT AND KEY IS SUS420J2.

TITLE	H2L28B□□□-WB04T**EN 外形寸法図 DIMENSION OF MODEL				
DRAWING NO.	H2L28B-WB04TEN				
USER					
NOTICE					
APPROVE	H.Hayashi	SCALE	1:3	UNIT in	DATE 2020.03.31
CHECK	M.Iijima				
DESIGN	A.Kobayashi				
NISSEI CORPORATION					