

REVISIONS

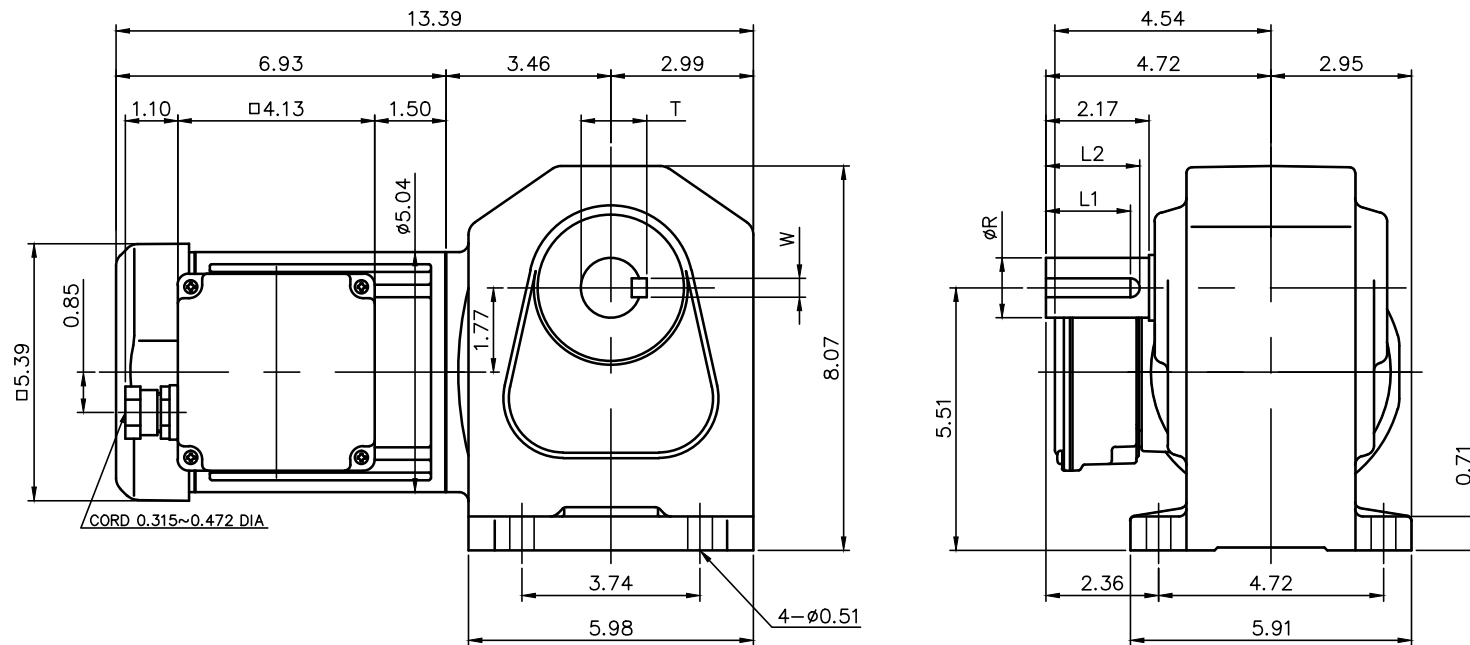

モータ仕様 MOTOR SPECIFICATION	
名称 TYPE	三相誘導電動機 THREE PHASE INDUCTION MOTOR
冷却方式 COOLING METHOD	全閉外扇形 TOTALLY ENCLOSED FAN COOLED
出力 MOTOR POWER	1/2 HP (0.4 kW)
定格 RATING	S1 CONT.
耐熱劣化 INS. CLASS	F
保護構造 IP RATING	IP65

モータ仕様 MOTOR SPECIFICATION						
**	電圧 VOLTAGE	周波数 FREQUENCY	回転速度 ROTATION SPEED	電流値 CURRENT VALUE	対応規格 COMPLIANT STANDARDS	高効率認証 EFFICIENCY STANDARDS
AV	208 V	60 Hz	1680 r/min	1.8 A	UL/cUL/CE	-
	230 V	60 Hz	1720 r/min	1.8 A		
	460 V	60 Hz	1720 r/min	0.9 A		
	400 V	50 Hz	1400 r/min	1.0 A		
EV	415 V	50 Hz	1390 r/min	0.96 A	UL/cUL	-
	440 V	50 Hz	1410 r/min	0.95 A		
	480 V	60 Hz	1680 r/min	0.82 A		
	575 V	60 Hz	1700 r/min	0.68 A		

減速機仕様 REDUCER SPECIFICATION		
名称 TYPE	GTR	
枠番 FRAME NO.	32	
減速比 RATIO	80 100 120 160 200 240	
潤滑 LUBRICATION	グリース GREASE	
塗装 PAINT COLOR	グレー (マンセル値 9B6/0.5) GREY (MANSEL CODE: 9B6/0.5)	

出力軸仕様 OUTPUT SHAFT SPECIFICATION							
FRAME NO	R	STANDARD /OPTION	DIAMETER TOLERANCE	L1	L2	T	W
32	1.2500 in 32 mm	STANDARD OPTION	+0.0/-0.0005 +0.0/-0.016	1.88 in 45 mm	2.00 in 50 mm	1.362 in 35 mm	0.2500 in 10 mm

- 製品型式「□□□」は減速比によって入る文字数が変わります。  
Number of characters on product model「□□□」varies depending on the reduction ratio.
- 製品型式「\*\*」には「AV」「EV」「MA」が入ります。  
Replace product model「\*\*」with「AV」「EV」「MA」.
- 出力軸・キーの材質は SUS420J2 を使用しています。  
THE MATERIAL OF THE OUTPUT SHAFT AND KEY IS SUS420J2.

TITLE	H2L32M□□□-WB04T**EN 外形寸法図 DIMENSION OF MODEL			
DRAWING NO.	H2L32M-WB04TEN			
USER				
NOTICE				
APPROVE	H.Hayashi	SCALE	1:4	UNIT in
CHECK	M.Iijima			DATE 2020.03.31
DESIGN	A.Kobayashi	NISSEI CORPORATION		