

REVISIONS

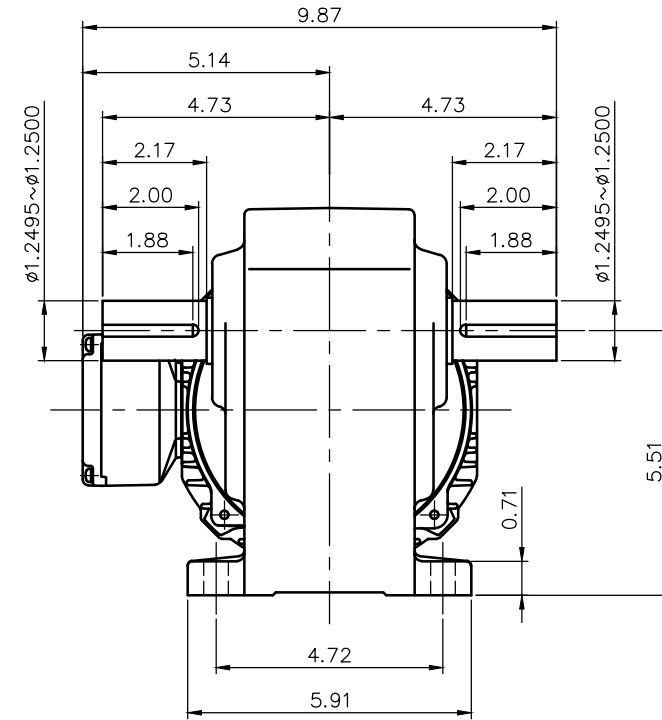
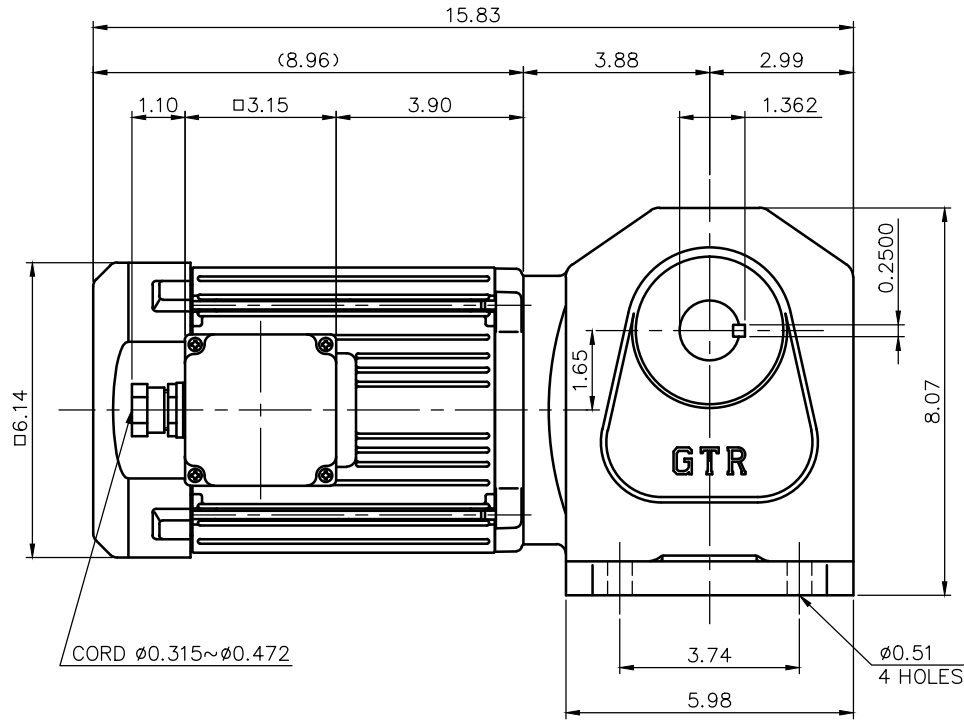

MOTOR SPECIFICATION

TYPE	3-PHASE INDUCTION MOTOR
FORM	TOTALLY ENCLOSED FAN COOLED P6
OUT PUT	1 HP
VOLTAGE	208/230/460/400 V
FREQ.	60/60/60/50 Hz
POLES	4
ROTATIONAL FREQUENCY	1800/1800/1800/1500 rpm
EFFICIENCY CLASS	IE3 EN60034-30 Standard
RATING	S1 CONT.
INS.CLASS	F

REDUCER SPECIFICATION

TYPE	GTR
FORM	32T
RATIO	1/5 1/10 1/15 1/20 1/25 1/30 1/40 1/50 1/60
LUBRICATION	GREASE

NOTE: THIS MOTOR IS AFFIXED WITH CE MARKING.  
 NOTE: THE GROUND LEAD SHOULD BE LONGER THAN THE SUPPLY LEAD FOR THE MOTOR.  
 NOTE: THIS MOTOR IS UL CERTIFIED MODEL. (UL1004-1)  
 NOTE: UL-LISTED MODEL NAME: MV6AEN

TITLE		H2L32T5~60-MV6AEN DIMENSION OF MODEL			
DRAWING NO.		H2L32T-MV6AEN			
USER					
NOTICE					
APPROVE	Y.Ikeda	SCALE	1/4	UNIT in	DATE 2015.05.01
CHECK	M.Iijima				
DESIGN	Y.Miura				
NISSEI CORPORATION					