

OPERATING MANUAL

DC Axial Flow Fans
MD Series

A Type (with alarm)
S Type (without alarm)
E Type (long-life)

Thank you for purchasing an Oriental Motor product. This Operating Manual describes product handling procedures and safety precautions.

- Please read it thoroughly to ensure safe operation.
- Always keep the manual where it is readily available.



Introduction

■ Before using the product



Only qualified personnel of electrical and mechanical engineering should work with the product. Use the product correctly after thoroughly reading the section "Safety precautions." In addition, be sure to observe the contents described in warning, caution, and note in this manual. The product described in this document has been designed and manufactured to be incorporated in general industrial equipment. Do not use for any other purpose. For the power supply, use a DC power supply with reinforced insulation on its primary and secondary sides. Oriental Motor Co., Ltd. is not responsible for any damage caused through failure to observe this warning.



Safety precautions

The precautions described below are intended to ensure the safe and correct use of the product, and to prevent the user and other personnel from exposure to the risk of injury. Use the product only after carefully reading and fully understanding these instructions.

 WARNING	Handling the product without observing the instructions that accompany a "WARNING" symbol may result in serious injury or death.
 CAUTION	Handling the product without observing the instructions that accompany a "CAUTION" symbol may result in injury or property damage.
 Note	The items under this heading contain important handling instructions that the user should observe to ensure safe use of the product.

[Description of graphic symbols]



	Indicates "prohibited" actions that must not be performed.
	Indicates "compulsory" actions that must be performed.

 WARNING	
	<ul style="list-style-type: none"> • Do not use the product in explosive or corrosive environments, in the presence of flammable gases, locations subjected to splashing water, or near combustibles. Doing so may cause fire or injury. • Do not transport, install, connect, or inspect the product while the power is supplied. Always turn off the power before carrying out these operations. Injury may result. • Do not forcibly bend, pull or pinch the lead wire. Doing so may result in fire. • Do not disassemble or modify the fan. Doing so may cause injury.
	<ul style="list-style-type: none"> • Assign qualified personnel to the task of installing, wiring, operating, inspecting, and troubleshooting the product. Handling by unqualified personnel may result in fire or injury. • Keep the input-power voltage within the specified range. Failure to do so may result in fire.

WARNING

	<ul style="list-style-type: none"> • For the power supply, use a DC power supply with reinforced insulation on its primary and secondary sides. Failure to do so may result in electric shock. • Perform connections securely according to the connection diagram. Failure to do so may result in fire or a skin burn(s). • Shut off the power to the fan in the event the rotating part (blades) is locked during operation and the burnout prevention circuit is activated. Otherwise, the fan will start unexpectedly when released from the locked condition. This may cause injury or damage to equipment. • Turn off the power in the event of a power failure. Otherwise, the fan will start unexpectedly when the power is restored. This may cause injury or damage to equipment.
---	--

CAUTION

	<ul style="list-style-type: none"> • Do not use the fan beyond its specifications. Doing so may result in injury or damage to equipment. • Keep your fingers and objects out of the openings in the fan. This may cause injury. • Do not lift the fan by holding the rotating part (blades) or lead wires of the fan. Doing so may cause injury. • Do not remove the lead wire of the fan from the frame hook. Doing so may cause damage to the lead wire. • Keep the area around the fan free of combustible materials. Failure to do so may result in fire or a skin burn(s). • Do not leave anything around the fan that would obstruct ventilation. Doing so may result in damage to equipment. • Do not touch the rotating part (blades) while operating. Doing so may cause injury. The use of the finger guard is recommended to ensure protection.
	<ul style="list-style-type: none"> • Before installing the fan, take measures against static electricity. Failure to do so may result in damage to equipment. • When an abnormal condition has occurred, immediately stop operation to turn off the power supply. Failure to do so may result in fire or injury. • Securely install the fan in an enclosure. Failure to do so may result in injury or damage to equipment.

Checking the product

■ Package contents

Verify that the items listed below are included.

Report any missing or damaged items to the branch or sales office from which you purchased the product.

- Fan 1 unit
- Instructions and Precautions for Safe Use 1 copy

■ Checking the model name

Verify the model name of the purchased product against the model shown on the name plate of the product.

Tell us the model name, product serial number, and manufacturing date shown on the name plate when you contact us.

MD S 17 51 F _ H - 24 _ _
 1 2 3 4 5 6 7 8 9 10
 Fan size

1	Series name	MD: MD Series
2	Type	A: A type (with alarm) S: S type (without alarm) E: E type (long-life)
3	Frame size	
4	Frame thickness	
5	Frame form	F: Side cut
6	Identification code	Y, Y2
7	Speed type	H: High speed Blank: Standard speed
8	Rated voltage	24: 24 VDC 12: 12 VDC
9	Additional function	L: Stall alarm (A type, E type) Blank: Low-speed alarm (A type only)
10	Reference number (E type only)	2

Installation

■ Installation location

Install the product in the following location that provides easy access for inspection.

- Inside an enclosure installed indoors
- Operating ambient temperature: -10 to $+60$ °C [$+14$ to $+140$ °F] *
(non-freezing, non-condensing)

Operating ambient humidity: 20 to 85%*(non-condensing)

* The operating ambient temperature and operating ambient humidity vary depending on the product. Check on the Oriental Motor Website for the product specifications.

- Area that is free of explosive atmosphere or toxic gas (such as sulfuric gas) or liquid
- Area not exposed to direct sun
- Area free of excessive amount of dust, iron particles or the like
- Area not subject to splashing water (rain, water droplets), oil (oil droplets) or other liquids
- Area not subject to continuous vibration or excessive shocks
- Area free of radioactive materials, magnetic fields or vacuum
- Area free of excessive electromagnetic noise (from welders, power machinery, etc.)

When using near a switching circuit or high-frequency power supply, the induced current may flow inside the fan due to electromagnetic noise (conductive noise, radiative noise). If the induced current flows, the electric corrosion is caused in the bearings of the fan. As a result, it may generate the noise or shorten the service life of the products. Use the fan in the environment that the electromagnetic noise does not cause.

■ Installation method

- Install the fan onto an appropriate flat metal plate having excellent vibration resistance and heat conductivity.
- Drill mounting holes in equipment, and secure the fan using screws.
- For directions of the air flow and blades rotation, see the arrow indicated on the side of the fan frame.
- Finger guards that can prevent fingers and foreign particles from entering are available as peripheral equipment (sold separately). Install as shown in the figure when using.

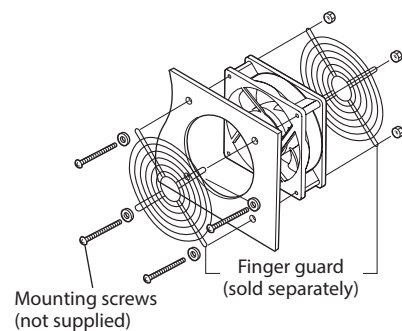

Fan size	Screw size	Tightening torque
420	M3	0.4 N·m (3.5 lb-in)
515*1, 625*2, 825, 925, 1225, 1238, 1451, 1751	M4	0.6 N·m (5.3 lb-in)

*1 When the finger guard is used, the screw size and tightening torque are M3 and 0.4 N·m (3.5 lb-in), respectively.

*2 The screw size and tightening torque of **MDA625-24** are M3 and 0.4 N·m (3.5 lb-in), respectively.

Connection

■ Connecting the power supply

The fan starts rotating when the DC power supply is turned on. Verify the voltage specification with the nameplate of the product, and input the suitable voltage.

For the **A** type fans, use the DC power supply whose rise time is 100 ms or less.

Note A voltage applied to the fan may be higher than the output voltage of the DC power supply depending on the wiring distance between the fan and the DC power supply. Use the fan in a state where a voltage applied to the fan does not exceed the voltage specification.

[Connection diagram]

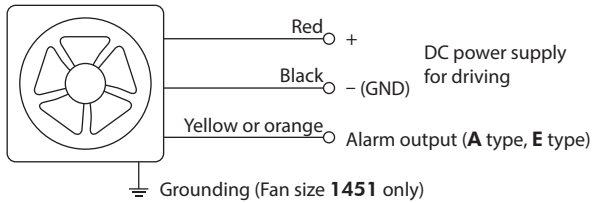

• Lead wire size: AWG24*

* The lead wire size of **MDA420, MDS420, MDA515, MDS515, and MDA925-24L** fans are AWG26.

• Connecting Protective Earth Terminal (⏚)
Ground using the Protective Earth Terminal provided on the product.

■ Connecting the alarm circuit

● Stall alarm (A type, E type)

If the fan stops rotating while the power is supplied, an alarm signal is output. The yellow lead wire or the orange lead wire is for alarm signal. GND of the DC power supply for driving and that of the alarm signal are common.

- Output circuit: Open-collector output
- Output status: L level when the fan rotates (internal transistor ON)
H level when the fan stops (internal transistor OFF)

Connection diagram	Delay function
<p>The diagram shows the fan's Yellow or orange terminal connected to a resistor R, which is connected to 27.6 VDC or less*. The Black terminal is connected to GND. A current of 5 mA or less is indicated through the resistor.</p>	To avoid an alarm detection when the fan starts rotating, a delay function is required externally. The delay time should be at least one second.

* 30 VDC or less for **MDA1451, MDE1225, MDE1238, MDE1451**

● Low-speed alarm (A type only)

An alarm signal is output when the speed of the fan falls the "alarm activation speed" or lower.

The yellow lead wire is for alarm signal. GND of the DC power supply for driving and that of the alarm signal are common.

- Output circuit: Open-collector output
- Output status: L level when the fan rotates normally (internal transistor ON)
H level when an alarm is output (internal transistor OFF)

Model	Connection diagram	Alarm activation speed [r/min]	Delay function
MDA625 MDA825	<p>The diagram shows the fan's Yellow terminal connected to a resistor R, which is connected to 30 VDC or less. The Black terminal is connected to GND. A current of 15 mA or less is indicated through the resistor.</p>	2300 ± 400 or less	To avoid an alarm detection when the fan starts rotating, a delay function is required externally. The delay time should be at least ten seconds.
MDA925	<p>The diagram shows the fan's Yellow terminal connected to a resistor R, which is connected to 30 VDC or less. The Black terminal is connected to GND. A current of 15 mA or less is indicated through the resistor.</p>	1900 ± 400 or less	The fan is equipped with an internal starting-delay circuit. The alarm function is enabled within ten seconds after the fan starts rotating.
MDA1225	<p>The diagram shows the fan's Yellow terminal connected to a resistor R, which is connected to 30 VDC or less. The Black terminal is connected to GND. A current of 15 mA or less is indicated through the resistor.</p>	2100 ± 400 or less	The fan is equipped with an internal starting-delay circuit. The alarm function is enabled within ten seconds after the fan starts rotating.
MDA1238	<p>The diagram shows the fan's Yellow terminal connected to a resistor R, which is connected to 30 VDC or less*. The Black terminal is connected to GND. A current of 15 mA or less* is indicated through the resistor.</p>	2200 ± 220 or less	The fan is equipped with an internal starting-delay circuit. The alarm function is enabled within ten seconds after the fan starts rotating.
MDA1451 MDA1751	<p>The diagram shows the fan's Yellow terminal connected to a resistor R, which is connected to 30 VDC or less*. The Black terminal is connected to GND. A current of 15 mA or less* is indicated through the resistor.</p>	1800 ± 400 or less	The fan is equipped with an internal starting-delay circuit. The alarm function is enabled within ten seconds after the fan starts rotating.

* 28 VDC or less and 10 mA or less for **MDA1238**

Overheat protection for locked condition

This fan is equipped with a built-in burnout prevention circuit. Since this circuit automatically controls the current flow to the windings when a locked condition is detected, it prevents the fan from burning out. The fan resumes operation automatically as soon as it is released from the locked condition. Turn off the power at the time of inspections.

Inspection and maintenance

■ Inspection

It is recommended that periodic inspections for the items listed below are conducted after each operation.

If an abnormal condition is noted, discontinue any use and contact your nearest Oriental Motor sales office.

● Inspection item

- Check if any of the mounting screws of the fan is loose.
- Check if the fan generates unusual noises.

■ Warranty

Check on the Oriental Motor Website for the product warranty.

■ Disposal

Dispose the product correctly in accordance with laws and regulations, or instructions of local governments.

Specifications

Check on the Oriental Motor Website for the product specifications.

Regulations and standards

■ UL Standards, CSA Standards, EN Standards

This product is recognized by UL under the UL, CSA and EN Standards.

Thermal class UL/CSA Standards: 105(A) EN Standards: 120 (E)

EN Standards: Some products are certified by TÜV.

The applicable standards and certification bodies vary depending on the product.

Check on the Oriental Motor Website for details.

● Installation conditions (EN/IEC Standards)

For incorporating in equipment

Overvoltage category: I

Pollution degree: 2

Protection against electric shock: Class III equipment

■ CE Marking

Some products are affixed the CE Marking under the EMC Directive.

Caution: This equipment is not intended for use in residential environments nor for use on a low-voltage public network supplied in residential premises, and it may not provide adequate protection to radio reception interference in such environments.

■ RoHS Directive

This products do not contain the substances exceeding the restriction values.

-
- Unauthorized reproduction or copying of all or part of this manual is prohibited.
 - Characteristics, specifications and dimensions are subject to change without notice.
 - **Orientalmotor** and **ORIX** are registered trademarks or trademarks of Oriental Motor Co., Ltd., in Japan and other countries.

© Copyright ORIENTAL MOTOR CO., LTD. 2023

Published in April 2025

- Please contact your nearest Oriental Motor office for further information.

ORIENTAL MOTOR U.S.A. CORP.
Technical Support Tel:800-468-3982
8:30am EST to 5:00pm PST (M-F)

ORIENTAL MOTOR (EUROPA) GmbH
Schiesstraße 44, 40549 Düsseldorf, Germany
Technical Support Tel:00 800/22 55 66 22

ORIENTAL MOTOR (UK) LTD.
Blythe Valley Business Park,
Central Blvd Blythe Valley Park,
Solihull B90 8AG, United Kingdom
Tel:+44-1926-671220

ORIENTAL MOTOR (FRANCE) SARL
Tel:+33-1 47 86 97 50

ORIENTAL MOTOR ITALIA s.r.l.
Tel:+39-02-93906347

ORIENTAL MOTOR CO., LTD.
4-8-1Higashiueno,Taito-ku,Tokyo 110-8536
Japan
Tel:+81-3-6744-0361
www.orientalmotor.co.jp/ja

ORIENTAL MOTOR ASIA PACIFIC PTE. LTD.
Singapore
Tel:1800-842-0280

ORIENTAL MOTOR (MALAYSIA) SDN. BHD.
Tel:1800-806-161

ORIENTAL MOTOR (THAILAND) CO., LTD.
Tel:1800-888-881

ORIENTAL MOTOR (INDIA) PVT. LTD.
Tel:1800-120-1995 (For English)
1800-121-4149 (For Hindi)

TAIWAN ORIENTAL MOTOR CO., LTD.
Tel:0800-060708

SHANGHAI ORIENTAL MOTOR CO., LTD.
Tel:400-820-6516

INA ORIENTAL MOTOR CO., LTD.
Korea
Tel:080-777-2042