

## OPERATING MANUAL

### Compact Linear Actuator DRL II Series

#### Built-in controller type

## Introduction

### Before use

Only qualified personnel should work with the product. Use the product correctly after thoroughly reading the section "Safety precautions". The product described in this manual has been designed and manufactured for use in general industrial machinery, and must not be used for any other purpose. For the driver's power supply, use a DC power supply with reinforced insulation on its primary and secondary sides. Oriental Motor Co., Ltd. is not responsible for any damage caused through failure to observe this warning.

### Operating manuals for the DRL II Series

Operating manuals for this product are listed below. After reading the following manuals, keep them in a convenient place so that you can reference them at any time.

- DRL II Series Actuator OPERATING MANUAL
- DRL II Series FLEX Built-in Controller OPERATING MANUAL (this document)
- CRK Series FLEX Built-in Controller OPERATING MANUAL

The OPERATING MANUAL for this product is common with the CRK Series. This manual does not come with the product. For details, contact your nearest Oriental Motor sales office.

### CE Marking

This product is affixed with the mark under the following directive.

### EMC Directive

Refer to "Compliance with the EMC Directive" of the CRK Series OPERATING MANUAL for details on compliance.

### RoHS Directive

This product does not contain the substances exceeding the restriction values.

### Checking the product

Verify that the items listed below are included. Report any missing or damaged items to the branch or sales office from which you purchased the product.

#### Items supplied with all actuator and driver package models

- Actuator ..... 1 unit
- Driver ..... 1 unit
- CN1 connector (3 pins) ..... 1 pc.
- CN2 connector cable [1 m (3.3 ft.), 40 pins] ..... 1 pc.
- CN4 connector lead wire [0.6 m (2 ft.), 5 pins] ..... 1 pc.
- Instructions and Precautions for Safe Use ..... 1 copy

#### Item supplied with the electromagnetic brake type actuator and driver package models

- Varistor ..... 1 pc.

#### Item supplied with the connector-coupled actuator and driver package models

Applicable product: All models for the DRL20/DRL28 and models of high-resolution motor for the DRL42/DRL60

- Actuator connector leads [0.6 m (2 ft.), 5 pins] ..... 1 pc.

Thank you for purchasing an Oriental Motor product. This Operating Manual describes product handling procedures and safety precautions.

- Please read it thoroughly to ensure safe operation.
- Always keep the manual where it is readily available.

## Names and functions of parts

### Front side of the driver

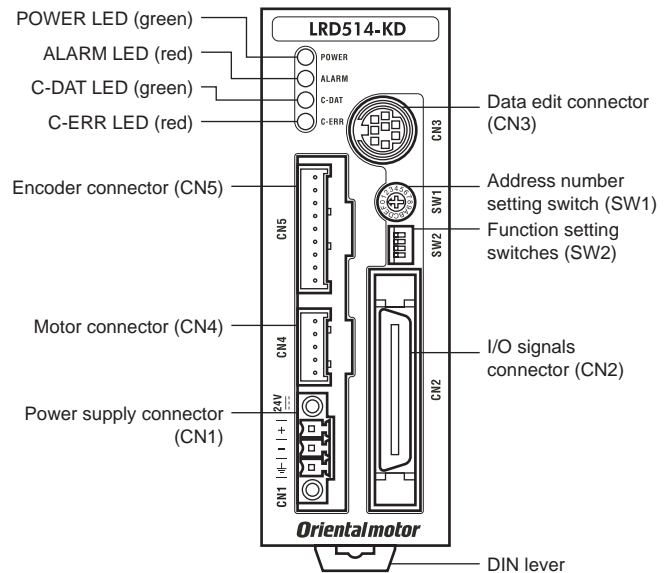

Name	Description
POWER LED (green)	This LED is lit while the power is input.
ALARM LED (red)	This LED will blink when an alarm generates (a protective function is triggered). The type of the generated alarm can be checked by counting the number of times the LED blinks.
C-DAT LED (green)	This LED will blink or illuminate steadily when the driver is communicating with the master station properly via RS-485 communication.
C-ERR LED (red)	This LED will illuminate when a RS-485 communication error occurs with the master station.
Address number setting switch (SW1)	This switch is used to set the address number of RS-485 communication.
Function setting switches (SW2)	No.1 to 3: Sets the baud rate of RS-485 communication. No.4: Sets the connection destination of RS-485 communication.
Power supply connector (CN1)	Connects the main power supply (+24 VDC) with the supplied connector.
I/O signals connector (CN2)	Connects I/O signals with the supplied lead wire/connector assembly.
Data edit connector (CN3)	Connects a PC in which the MEXE02 has been installed, or the OPX-2A.
Actuator connector (CN4)	Connects the actuator.
Encoder connector (CN5)	Not used.

● Upper side of the driver

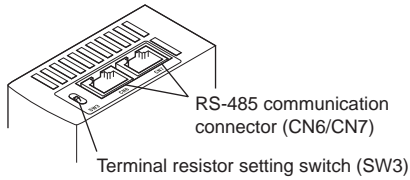

Name	Description
Termination resistor setting switch (SW3)	This switch is used to set the termination resistor (120 Ω) of RS-485 communication.
RS-485 communication connector (CN6/CN7)	Connects the RS-485 communication cable.

## Installation

### ■ Location for installation

The actuator and driver has been designed and manufactured to be installed within another device.

Install it in a well-ventilated location that provides easy access for inspection. The location must also satisfy the following conditions:

- Inside an enclosure that is installed indoors (provide vent holes)
- Operating ambient temperature  
Actuator: -10 to +40 °C (+14 to +104 °F) (non-freezing)  
Driver: 0 to +40 °C (+32 to +104 °F) (non-freezing)
- Operating ambient humidity 85% or less (non-condensing)
- Area that is free of explosive atmosphere or toxic gas (such as sulfuric gas) or liquid
- Area not exposed to direct sun
- Area free of excessive amount of dust, iron particles or the like
- Area not subject to splashing water (rain, water droplets), oil (oil droplets) or other liquids
- Area free of excessive salt
- Area not subject to continuous vibration or excessive shocks
- Area free of excessive electromagnetic noise (from welders, power machinery, etc.)
- Area free of radioactive materials, magnetic fields or vacuum
- Up to 1000 m (3300 ft.) above sea level

### ■ Installing the driver

#### ● Installation direction

Use a DIN rail 35 mm (1.38 in.) wide to mount the driver. Provide 50 mm (1.97 in.) clearances in the horizontal and vertical directions between the driver and enclosure or other equipment within the enclosure.

Refer to the figure below for the required distances between adjacent drivers when two or more drivers are installed in parallel.



**Note** Be sure to install (position) the driver vertically. When the driver is installed in any position other than vertical, the heat radiation effect of the driver will drop.

#### ● LRD503-KD, LRD507-KD

Two or more units can be placed in contact with each other in the horizontal direction. Provide a clearance of 50 mm (1.97 in.) or more in the vertical direction.

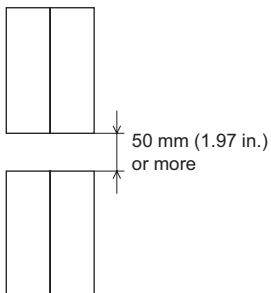

#### ● LRD514-KD

Provide a clearance of 20 mm (0.79 in.) or more in the horizontal direction, and 50 mm (1.97 in.) or more in the vertical direction.

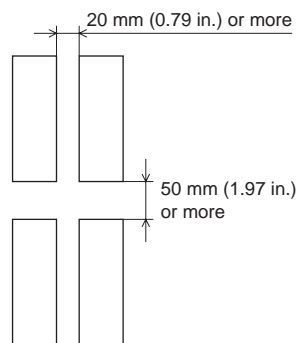

#### ● When using the LRD514-KD in parallel with another driver

Another unit can be placed in contact with the right side of LRD514-KD. Provide a clearance of 20 mm (0.79 in.) or more on the left side of LRD514-KD where a heat sink is located.

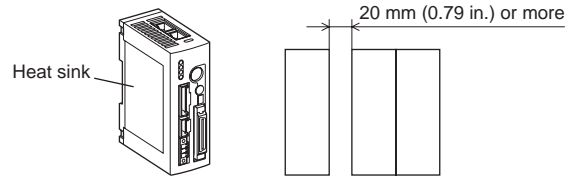

### ● Installation method

Push up the driver's DIN lever until it locks. Hang the hook at the rear of the DIN rail, and push in the driver. After installation, fix the both sides of the driver with the end plate.

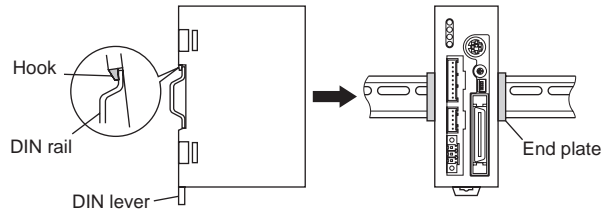

#### Removing from DIN rail

Pull the DIN lever down until it locks using a flat tip screwdriver, and lift the bottom of the driver to remove it from the rail. Use a force of about 10 to 20 N (2.2 to 4.5 lb.) to pull the DIN lever down to lock it. Excessive force may damage the DIN lever.

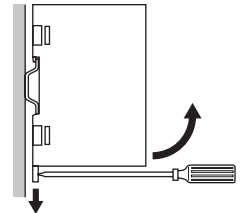

## Pin assignments lists

### ■ CN1: Power supply connector

Connect using the supplied CN1 connector (3 pins).

Pin No.	Name	Description
1	+24 VDC	+24 VDC power supply input
2	GND	Power supply GND
3	FG	Frame Ground

### ■ CN2: I/O signals connector

Connect using the supplied CN2 connector cable.

#### ● Upper ribbon cable

Lead wire color	Pin No.	Signal name	Description
Brown-1	A1	IN-COM0	Input common
Red-1	A2	START	Start input
Orange-1	A3	ALM-RST	Alarm reset input
Yellow-1	A4	AWO	All windings off input
Green-1	A5	STOP	Stop input
Blue-1	A6	M0	Data selection input
Purple-1	A7	M1	
Gray-1	A8	M2	
White-1	A9	M3	
Black-1	A10	M4	
Brown-2	A11	M5	
Red-2	A12	HOME/P-PRESET	Return-to-home/position preset input
Orange-2	A13	FWD	Forward input
Yellow-2	A14	RVS	Reverse input
Green-2	A15	+LS	+Limit sensor input
Blue-2	A16	-LS	-Limit sensor input

Lead wire color	Pin No.	Signal name	Description
Purple-2	A17	HOMES	Mechanical home sensor input
Gray-2	A18	SLIT	Slit sensor input
White-2	A19	N.C.	Not used
Black-2	A20	IN-COM1	Sensor input common

#### • Lower ribbon cable

Control output 1 to 4 settings can be changed using the "OUT1 to OUT4 signal mode selection" parameters.

Lead wire color	Pin No.	Signal name	Description
Brown-3	B1	MOVE+	Motor moving output
Red-3	B2	MOVE-	
Orange-3	B3	ALM+	Alarm output
Yellow-3	B4	ALM-	
Green-3	B5	OUT1+	Control output 1 (initial value: AREA)
Blue-3	B6	OUT1-	
Purple-3	B7	OUT2+	Control output 2 (initial value: READY)
Gray-3	B8	OUT2-	
White-3	B9	OUT3+	Control output 3 (initial value: WNG)
Black-3	B10	OUT3-	
Brown-4	B11	OUT4+	Control output 4 (initial value: HOME-P)
Red-4	B12	OUT4-	
Orange-4	B13	N.C.	Not used
Yellow-4	B14	N.C.	Not used
Green-4	B15	PLS-OUT+	Pulse output (Line driver output)
Blue-4	B16	PLS-OUT-	
Purple-4	B17	DIR-OUT+	Direction output (Line driver output)
Gray-4	B18	DIR-OUT-	
White-4	B19	GND	GND
Black-4	B20	N.C.	Not used

#### ■ CN4: Actuator connector

Connect using the supplied CN4 connector cable (5 pins).

Pin No.	Description
1	Blue motor lead
2	Red motor lead
3	Orange motor lead
4	Green motor lead
5	Black motor lead

#### ■ CN6/7: RS-485 communication connector

Connect this cable if you want to control your product via RS-485 communication.

Pin No.	Signal name	Description
1	N.C.	Not used
2	GND	GND
3	TR+	RS-485 communication signal (+)
4	N.C.	Not used
5	N.C.	Not used
6	TR-	RS-485 communication signal (-)
7	N.C.	Not used
8	N.C.	Not used

## Setting the switches



Be sure to turn off the driver power before setting the switches. If the switches are set while the power is still on, the new switch settings will not become effective until the driver power is cycled.

#### ■ Address number

Set the address number using the address number setting switch (SW1) and "communication axis number" parameter.

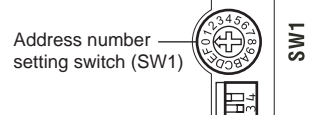

Factory setting: 0 (address number 0)

SW1	Address number	SW1	Address number
0	0	8	8
1	1	9	9
2	2	A	10
3	3	B	11
4	4	C	12
5	5	D	13
6	6	E	14
7	7	F	Setting value of "communication axis number" parameter *

\* The default value of the "communication axis number" parameter is "15". Set the "communication axis number" parameter using the **OPX-2A** or **MEXE02**.

#### ■ Setting the connection destination

Set the connection destination of RS-485 communication using position No.4 of the function setting switch (SW2).

Factory setting: OFF (network converter)

SW2-No.4	Connection destination
ON	General master device
OFF	Network converter

#### ■ Baud rate

Set the baud rate using Nos. 1 to 3 of the function setting switch (SW2) to.

Factory setting: All ON (625,000 bps)

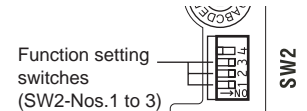

Baud rate (bps)	SW2-No.3	SW2-No.2	SW2-No.1
9600	OFF	OFF	OFF
19200	OFF	OFF	ON
38400	OFF	ON	OFF
57600	OFF	ON	ON
115,200	ON	OFF	OFF
250,000	ON	OFF	ON
312,500	ON	ON	OFF
625,000	ON	ON	ON

#### ■ Termination resistor

Set the Termination resistor for RS-485 communication (120 Ω) using the Termination resistor setting switch (SW3).

Factory setting: OFF (Termination resistor disabled)

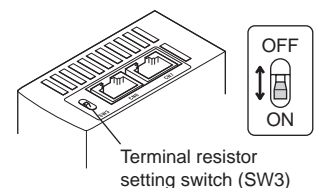

SW3	Termination resistor (120 Ω)
OFF	Disabled
ON	Enabled

## Safety precautions

The precautions described below are intended to prevent danger or injury to the user and other personnel through safe, correct use of the product. Use the product only after carefully reading and fully understanding these instructions.

### WARNING

Handling the product without observing the instructions that accompany a "Warning" symbol may result in serious injury or death.

#### General

- Do not use the product in explosive or corrosive environments, in the presence of flammable gases, locations subjected to splashing water, or near combustibles. Doing so may result in fire or injury.
- Assign qualified personnel the task of installing, wiring, operating/controlling, inspecting and troubleshooting the product. Failure to do so may result in fire, injury or damage to equipment.
- The actuator will lose its holding torque when its excitation or the power supply is turned off. Take measures to keep the moving part in position if the product is used in vertical operations such as elevator applications. Failure to provide such measures may cause the moving parts to fall, resulting in injury or damage to equipment.
- Do not use the brake mechanism of the actuator with an electromagnetic brake for stopping or for safety purposes. The electromagnetic brake is used for the purpose to hold the moving part and actuator in position. Failure to do so may result in injury or damage to equipment.
- With certain types of alarms (protective functions), the actuator may stop when the alarm generates and the holding torque will be lost as a result. This may result in injury or damage to equipment.
- When the alarm is generated, first remove the cause and then clear the alarm. Continuing the operation without removing the cause of the problem may cause malfunction of the actuator and driver, leading to injury or damage to equipment.

#### Connection

- Keep the input power voltage of the driver within the specified range. Failure to do so may result in fire.
- For the driver power supply, use a DC power supply with reinforced insulation on its primary and secondary sides. Failure to do so may result in electric shock.
- Connect the cables securely according to the wiring diagram. Failure to do so may result in fire.
- Do not forcibly bend, pull or pinch the cable or lead wire. Doing so may cause fire. Repetitive stress or overstress on the connection part may cause damage to the product.

#### Operation

- Turn off the driver power in the event of a power failure. Or the actuator may suddenly start when the power is restored and this may cause injury or damage to equipment.
- Do not turn the excitation to off while the actuator operates. The actuator will stop and lose its holding power. Doing so may result in injury or damage to equipment.
- Configure an interlock circuit using a sequence program so that when a RS-485 communication error occurs, the entire system including the driver will operate on the safe side.

#### Repair, disassembly and modification

- Do not disassemble or modify the actuator and driver. This may cause injury. Refer all such internal inspections and repairs to the branch or sales office from which you purchased the product.

### CAUTION

Handling the product without observing the instructions that accompany a "Caution" symbol may result in injury or property damage.

#### General

- Do not use the actuator and driver beyond its specifications. Doing so may result in injury or damage to equipment.
- Keep your fingers and objects out of the openings in the actuator and driver. Failure to do so may result in fire or injury.
- Do not touch the actuator and driver while operating or immediately after stopping. The actuator and driver may be hot and cause skin burn(s).

#### Transportation

- Do not hold the moving part (screw shaft) of the actuator, cable or lead wire. This may cause injury.

#### Installation

- Install the actuator and driver in the enclosure. Failure to do so may cause injury.
- Keep the area around the actuator and driver free of combustible materials. Failure to do so may result in fire or skin burn(s).
- Provide a cover over the moving part (screw shaft) of the actuator. Failure to do so may result in injury.

#### Connection

- The power supply connector (CN1), I/O connector (CN2), data edit connector (CN3) and RS-485 communication connector (CN6/CN7) of the driver are not electrically insulated. When grounding the positive terminal of the power supply, do not connect any equipment (PC, etc.) whose negative terminal is grounded. Doing so may cause the driver and PC to short, damaging both.
- When connecting, check the indication of the driver case and pay attention to the polarity of the power supply. Reverse-polarity connection may cause damage to the driver. The power supply circuit and the RS-485 communication circuit are not insulated. Therefore, when controlling multiple drivers via RS-485 communication, the reverse polarity of the power supply will cause a short circuit and may result in damage to the drivers.

#### Operation

- Use an actuator and driver only in the specified combination. An incorrect combination may cause a fire.
- Provide an emergency stop device or emergency stop circuit external to the equipment so that the entire equipment will operate safely in the event of a system failure or malfunction.
- Before supplying power to the driver, turn all control input to the driver to OFF. Otherwise, the actuator may suddenly start when the power is turned on and it may cause injury or damage to equipment.
- Set a suitable speed and acceleration/deceleration rate. Improper setting may cause loss of the motor synchronism of the actuator and moving the load to an unexpected direction, which may result in injury or damage to equipment.
- Do not touch the moving part (screw shaft) of the actuator while operating. This may cause injury.
- Before moving the moving part (screw shaft) of the actuator directly by the hands, confirm that the power supply or actuator excitation is turned off and the actuator current is cut off. Failure to do so may result in injury.
- The actuator surface temperature may exceed 70 °C (158 °F) even under normal operating conditions. If the operator is allowed to approach the running actuator, attach a warning label as shown below in a conspicuous position. Failure to do so may result in skin burn(s).
- Immediately when trouble has occurred, stop running and turn off the driver power. Failure to do so may result in fire or injury.
- Static electricity may cause the driver to malfunction or suffer damage. Do not touch the driver while the driver power is on. Always use an insulated screwdriver to adjust the driver switches.



Warning label

#### Disposal

- To dispose of the actuator or driver, disassemble it into parts and components as much as possible and dispose of individual parts/components as industrial waste. If you have any question, contact your nearest Oriental Motor branch or sales office.

- Unauthorized reproduction or copying of all or part of this manual is prohibited.
- Oriental Motor shall not be liable whatsoever for any problems relating to industrial property rights arising from use of any information, circuit, equipment or device provided or referenced in this manual.
- Characteristics, specifications and dimensions are subject to change without notice.
- While we make every effort to offer accurate information in the manual, we welcome your input. Should you find unclear descriptions, errors or omissions, please contact the nearest office.
- **Orientalmotor** and **FLEXO** are registered trademark or trademark of Oriental Motor Co., Ltd., in Japan and other countries.

© Copyright ORIENTAL MOTOR CO., LTD. 2012

Published in January 2026

ORIENTAL MOTOR U.S.A. CORP  
Technical Support Tel:800-468-3982  
8:30am EST to 5:00pm PST (M-F)

ORIENTAL MOTOR (EUROPA) GmbH  
Schiessstraße 44, 40549 Düsseldorf, Germany  
Technical Support Tel:00 800/22 55 66 22

ORIENTAL MOTOR (UK) LTD.  
Blythe Valley Business Park,  
Central Blvd Blythe Valley Park,  
Solihull B90 8AG, United Kingdom  
Tel:+44-1926-671220

ORIENTAL MOTOR (FRANCE) SARL  
Tel:+33-1 47 86 97 50

ORIENTAL MOTOR ITALIA s.r.l.  
Tel:+39-02-93906347

ORIENTAL MOTOR CO., LTD.  
4-8-1 Higashiueno, Taito-ku, Tokyo 110-8536  
Japan  
Tel:+81-3-6744-0361  
www.orientalmotor.co.jp/ja

ORIENTAL MOTOR ASIA PACIFIC PTE. LTD.  
Singapore  
Tel:1800-842-0280

ORIENTAL MOTOR (MALAYSIA) SDN. BHD.  
Tel:1800-806-161

ORIENTAL MOTOR (THAILAND) CO., LTD.  
Tel:1800-888-881

ORIENTAL MOTOR (INDIA) PVT. LTD.  
Tel:1800-120-1995 (For English)  
1800-121-4149 (For Hindi)

TAIWAN ORIENTAL MOTOR CO., LTD.  
Tel:0800-060708

SHANGHAI ORIENTAL MOTOR CO., LTD.  
Tel:400-820-6516

INA ORIENTAL MOTOR CO., LTD.  
Korea  
Tel:080-777-2042