

## Motorized Cylinder

# **EAC Series Actuator Edition**

---

## **OPERATING MANUAL**

### **Table of contents**

<b>1</b>	<b>Introduction .....</b>	<b>2</b>	<b>6</b>	<b>Connection .....</b>	<b>22</b>
<b>2</b>	<b>Safety precautions .....</b>	<b>4</b>	<b>7</b>	<b>Maintenance.....</b>	<b>23</b>
<b>3</b>	<b>Precautions for use.....</b>	<b>7</b>	<b>8</b>	<b>Standards, general</b>	
<b>4</b>	<b>Preparation .....</b>	<b>9</b>		<b>specifications.....</b>	<b>30</b>
<b>5</b>	<b>Installation.....</b>	<b>13</b>			

---

Thank you for purchasing an Oriental Motor product.  
This Manual describes product handling procedures and safety precautions.

- Please read it thoroughly to ensure safe operation.
- Always keep the manual where it is readily available.

# 1 Introduction

---

## 1-1 Introduction

Only qualified personnel of electrical and mechanical engineering should work with the product. Use the product correctly after thoroughly reading the "2 Safety precautions" on p.4. In addition, be sure to observe the contents described in warning, caution, and note in this manual. The product described in this manual is designed and manufactured to be incorporated in general industrial equipment. Do not use for any other purpose. Oriental Motor Co., Ltd. Is not responsible for any compensation for damage caused through failure to observe this warning.

## 1-2 Related operating manuals

For operating manuals, download from Oriental Motor Website Download Page or contact your nearest Oriental Motor sales office.

### ■ EAC Series equipped with the AZ Series

- **EAC** Series OPERATING MANUAL Actuator Edition (this document)
- **AZ** Series/Motorized actuator equipped with **AZ** Series OPERATING MANUAL Function Edition
- Motorized Actuator OPERATING MANUAL Function Setting Edition
- Recovery Guide

Refer to the operating manual of the driver for contents not described in these manuals.

### ■ EAC Series equipped with the AR Series

- **EAC** Series OPERATING MANUAL Actuator Edition (this document)
- **AR** Series/Motorized actuator equipped with **AR** Series USER MANUAL
- Motorized Actuator OPERATING MANUAL Function Setting Edition

## 1-3 Equipped motor list

These are the lists of the motor model that is equipped in the **EAC** Series.

The power supply current capacity of the drivers to be combined with the motorized cylinders are described in the operating manual of the driver.

Since the motor model is described in the operating manual of the driver, check by reference to those described in the tables.

### ■ EAC Series equipped with the AZ Series

#### ● AC power input type

Motorized cylinder model	Motor model
EACM4○○○○○AZAC-○	<b>AZM46AC</b>
EACM4○○○○○AZMC-○	<b>AZM46MC</b>
EACM6○○○○○AZAC-○	<b>AZM66AC</b>
EACM6○○○○○AZMC-○	<b>AZM66MC</b>

#### ● DC power input type

Motorized cylinder model	Motor model
EACM2○○○○○AZAK-○	<b>AZM24AK</b>
EACM4○○○○○AZAK-○	<b>AZM46AK</b>
EACM4○○○○○AZMK-○	<b>AZM46MK</b>
EACM6○○○○○AZAK-○	<b>AZM66AK</b>
EACM6○○○○○AZMK-○	<b>AZM66MK</b>

### ■ EAC Series equipped with the AR Series

#### ● AC power input type

Motorized cylinder model	Motor model
EACM4○○○○○ARAC-○	<b>ARM46AC</b>
EACM4○○○○○ARMC-○	<b>ARM46MC</b>
EACM6○○○○○ARAC-○	<b>ARM66AC</b>
EACM6○○○○○ARMC-○	<b>ARM66MC</b>

#### ● DC power input type

Motorized cylinder model	Motor model
EACM2○○○○○ARAK-○	<b>ARM24SAK</b>
EACM2○○○○○ARMK-○	<b>ARM24SMK</b>
EACM4○○○○○ARAK-○	<b>ARM46SAK</b>
EACM4○○○○○ARMK-○	<b>ARM46SMK</b>
EACM6○○○○○ARAK-○	<b>ARM66SAK</b>
EACM6○○○○○ARMK-○	<b>ARM66SMK</b>

# 2 Safety precautions



The precautions described below are intended to ensure the safe and correct use of the product, and to prevent the customer and others from exposure to the risk of injury. Use the product only after carefully reading and fully understanding these instructions.

You must not operate the motorized actuator (operate the equipment for the specified purpose) if the machine in which the motorized actuator is installed does not satisfy the related safety standards.



The factory safety manager or safety personnel in charge of the applicable machine must ensure that the machine is operated only by qualified personnel who are familiar with the operation of electronic equipment, and thereby prevent injury or damage to the equipment.



The term "qualified personnel" refers to persons who have received the necessary training or education and have pertinent experience; who are familiar with the relevant standards, regulations, accident-prevention rules and inspection conditions; who are authorized by the factory safety manager to engage in the necessary activities; and who have the ability to discern and prevent potential dangers.

### Description of signs

 <b>WARNING</b>	Handling the product without observing the instructions that accompany a "WARNING" symbol may result in death or serious bodily injury.
 <b>CAUTION</b>	Handling the product without observing the instructions that accompany a "CAUTION" symbol may result in bodily injury or property damage.
 <b>Note</b>	The items under this heading contain important handling instructions that the user should observe to ensure the safe use of the product.

### Description of graphic symbols

	Indicates "prohibited" actions that must not be performed.		Indicates "compulsory" actions that must be performed.
-------------------------------------------------------------------------------------	------------------------------------------------------------	-------------------------------------------------------------------------------------	--------------------------------------------------------

 <b>WARNING</b>	
	<ul style="list-style-type: none"> <li>• Do not use the product in explosive or corrosive environments, in the presence of flammable gases, in places subjected to splashing water, or near combustibles. Doing so may result in fire, electric shock, or injury.</li> <li>• Do not transport, install, connect or inspect the motorized cylinder while the power is supplied. Doing so may result in electric shock.</li> <li>• Do not forcibly bend, pull or pinch the cable. Doing so may result in electric shock or fire.</li> <li>• Do not disassemble or modify the product. Doing so may result in injury or damage to equipment.</li> <li>• Never use a motorized cylinder in a medical device used in connection with the maintenance or management of human life or health, or in a transportation system whose purpose is to move or carry people.</li> <li>• Do not use the brake mechanism of the electromagnetic brake for braking or as a safety brake. Doing so may result in injury or damage to equipment.</li> <li>• Do not hit the rod of the motorized cylinder to the mechanical stopper other than push-motion return-to-home operation and push-motion operation. Doing so may result in injury or damage to equipment.</li> </ul>

## ⚠ WARNING



- Assign qualified personnel to the task of installing, wiring, operating/controlling, inspecting, and troubleshooting the product. Handling by unqualified personnel may result in fire, electric shock, injury, or damage to equipment.
- Take measures to keep the moving part in position if the motorized cylinder is used in vertical operations such as elevating equipment. Failure to do so may result in injury or damage to equipment.
- Operate the data setter outside the safety fence. Failure to do so may result in injury.
- Be sure to provide a safety cage conforming to EN ISO 13857 to prevent persons from entering the moving range of the motorized cylinder while power is supplied to the motorized cylinder. Turn off the main power to the driver before performing adjustment or inspection in which the rod is moved manually. Accidental contact may result in serious injury.
- When an alarm is generated in the driver (any of the driver's protective functions is triggered), take measures to hold the moving part in a specific position since the motorized cylinder stops and loses its holding torque. Failure to do so may result in injury or damage to equipment.
- Install the motorized cylinder inside an enclosure. Failure to do so may result in electric shock or injury.
- Be sure to ground the AC input type motorized cylinder as it is Class I equipment. Failure to do so may result in electric shock.
- Provide an emergency stop device or emergency stop circuit externally so that the entire equipment will operate safely in the event of a system failure or malfunction. Failure to do so may result in injury.
- Perform the return-to-home operation after the power is restored. If backing up the battery, perform the absolute positioning operation. Failure to do so may result in injury or damage to equipment.
- Operate the motorized cylinder after setting the resolution, moving direction and other parameters. If the motorized cylinder is operated without setting parameters, the rod may move to unexpected directions or run at unexpected speeds, causing injury or damage to equipment. (A variety of parameters have been set to the motorized cylinder that equipped with the **AZ** Series at the time of shipment.)
- When the motor of the motorized cylinder equipped with the **AZ** Series is replaced, be sure to create the recovery data file in accordance with the **AZ** Series OPERATING MANUAL Function Edition or Recovery Guide before starting operation of the equipment. If the replacement is not performed in accordance with the procedures, the rod may move to unexpected directions or run at unexpected speeds, causing injury or damage to equipment.
- After replacing the driver, set the resolution, moving direction or other parameters before operating the motorized cylinder. If the motorized cylinder is operated without setting parameters, the rod may move to unexpected directions or run at unexpected speeds, causing injury or damage to equipment.
- Be sure to secure the motorized cylinder according to the screw size and tightening torque which are specified in this manual. Failure to do so may result in injury or damage to equipment.

## ⚠ CAUTION



- Do not use the motorized cylinder beyond its specifications. Doing so may result in electric shock, injury or damage to equipment.
- Keep your fingers and objects out of the openings in the motorized cylinder. Failure to do so may result in fire, electric shock or injury.
- Do not touch the motorized cylinder while operating or immediately after stopping. Doing so may result in a skin burn(s).
- Do not carry the motorized cylinder by holding its cables or its moving part. Doing so may result in injury.
- Keep the area around the motorized cylinder free of combustible materials. Failure to do so may result in fire or a skin burn(s).
- Leave nothing around the motorized cylinder that would obstruct ventilation. Failure to do so may result in damage to equipment.
- Do not touch the moving part during operation. Doing so may result in injury.
- Do not touch the terminals while conducting the insulation resistance measurement or the dielectric strength test. Doing so may result in electric shock.

 **CAUTION**



- Use a motorized cylinder and driver only in the specified combination. An incorrect combination may result in a fire.
- The motorized cylinder is very heavy. When transporting or installing the motorized cylinder, make sure two persons work together to carry out the necessary tasks. Failure to do so may result in injury.
- Wear a helmet, safety shoes, gloves or other protective gear when transporting or installing the motorized cylinder. Failure to do so may result in injury.
- When replacing the motor for the motorized cylinder, use the motor of the same model name that had been combined at the time of shipment. If a motor which series and size are different from the original one is combined, the motorized cylinder will not meet specifications and also injury or equipment damage may result.
- The motor surface temperature may exceed 70 °C (158 °F) even under normal operating conditions. If the operator is allowed to approach the motorized cylinder in operation, affix a warning label shown in the figure on a conspicuous position. Failure to do so may result in a skin burn(s).



Warning label

## 3 Precautions for use

This section covers restrictions and requirements the user should consider when using the product.

### ■ General

#### ● Be sure to use our cable to connect the motorized cylinder and the driver.

In the following cases, purchase our cable separately. Check on the Oriental Motor Website for the model name of cables.

- If a flexible cable is to be used.
- If a cable of 3 m (9.8 ft.) or longer is to be used.
- If a motor and driver package without a cable was purchased.
- If an actuator only was purchased.

#### ● When conducting the insulation resistance measurement or the dielectric strength test, be sure to separate the connection between the motorized cylinder and the driver.

Conducting the insulation resistance measurement or dielectric strength test with the motorized cylinder and driver connected may result in damage to the product.

#### ● Do not make an impact with the motorized cylinder.

Do not drop the motorized cylinder. Also, do not hit the motorized cylinder on something hard. Doing so may cause the positioning accuracy decrease, the motorized cylinder damage or the product service life reduction.

#### ● Make sure not to hit or apply a strong impact on the encoder (ABZO sensor).

- The warning label shown in the right is indicated on the motor part of the motorized cylinder equipped with the **AZ** Series.
- Making a strong impact on an encoder (ABZO sensor) may cause the motorized cylinder malfunction or damage to the encoder (ABZO sensor). When transporting the motorized cylinder or installing a load, handle the motorized cylinder carefully not to make a strong impact on the moving part.

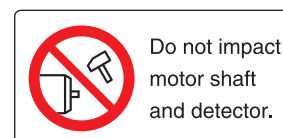

Warning label

#### ● Do not move the encoder (ABZO sensor) toward a strong magnetic field.

A magnetic sensor is built into the encoder (ABZO sensor). If the motorized cylinder is installed close to equipment which generates a strong magnetic field, the encoder (ABZO sensor) may break or malfunction. Make sure that the magnetic flux density on the surface of the encoder (ABZO sensor) does not exceed the values in the table. For the manufacturing date of an equipped motor, check the nameplate on the motor.

Manufacturing date of equipped motor	Cylinder model	Magnetic flux density	
		When transporting and storing	When operating
After October 2023	All	10 mT	10 mT
Before September 2023	<b>EACM2</b>	5 mT	2 mT *
	<b>EACM4, EACM6</b>	10 mT	10 mT

\* When the magnetic flux density is exceeding 1 mT and 2 mT or less, use in an environment where the operating ambient temperature is exceeding 20 °C (68 °F) and 40 °C (104 °F) or less.

#### ● Meshing noise of mechanical sensor

A gear type mechanical sensor is built into the encoder (ABZO sensor). Although the meshing noise of gears may generate, it is not malfunction.

### ■ Temperature

#### ● Use the motorized cylinder equipped with the **AZ** Series in conditions where the motor surface temperature does not exceed 80 °C (176 °F).

The motor surface temperature may exceed 80 °C (176 °F) under certain conditions (ambient temperature, operating speed, duty cycle, etc.). In order to protect the encoder (ABZO sensor), use the motorized cylinder in conditions where the surface temperature does not exceed 80 °C (176 °F). If the encoder (ABZO sensor) temperature reaches the upper limit, the motor overheat alarm will generate.

- Use the motorized cylinder equipped with the AR Series in conditions where the motor surface temperature does not exceed 100 °C (212 °F).

The motorized cylinder does not have a function to protect from overheating. The motor surface temperature may exceed 100 °C (212 °F) under certain conditions (ambient temperature, operating speed, duty cycle, etc.). To prevent the motor bearings (ball bearings) from reaching its usable life quickly, use the motorized cylinder in conditions where the surface temperature does not exceed 100 °C (212 °F).

## ■ Operation

- In the case of the DC power input type products, the maximum speed may not be reached depending on the ambient temperature or the length of the motor cable.

- Holding torque at standstill

When the motorized cylinder stops, the holding torque will be reduced by the current cutback function of the driver. When selecting the motorized cylinder, check the holding torque at standstill in the specifications on the catalog.

- Do not use the brake mechanism of the electromagnetic brake for braking or as a safety brake.

- Do not use the electromagnetic brake as a means to decelerate and stop the motorized cylinder. The brake hub of the electromagnetic brake will wear significantly and the braking force will drop if used to stop the motor. The electromagnetic brake is a power-off activated type. This means that although it helps maintain the position of the load in the event of power outage, etc., this brake cannot securely hold the load in place. Accordingly, do not use the electromagnetic brake as a safety brake. To use the electromagnetic brake to hold the load in place, do so after the motorized cylinder has stopped.
- The EACM2 type equipped with the AZ Series does not have the models with an electromagnetic brake. Take measures to keep the moving part in position for vertical operations such as elevator applications.

## ■ Notes when the connection cable is used

Note the following points when our cable is used.

- When inserting the connector

Hold the connector main body, and insert it in straight securely. Inserting the connector in an inclined state may result in damage to terminals or a connection failure.

- When pulling out the connector

Pull out the connector in straight while releasing the lock part of the connector. Pulling out the connector with holding the cable (lead wire) may result in damage to the connector.

- Bending radius of cable

Use the cable in a state where the bending radius of the cable is more than six times of the cable diameter.

Do not bend the lead wires part or fix it with a clamp. Doing so may cause damage to the connector.

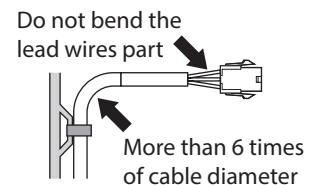

- How to fix the cable

Fix the cable near the connectors at two places as shown in the figure or fix it with a wide clamp to take measures to prevent stress from being applied to the connectors.

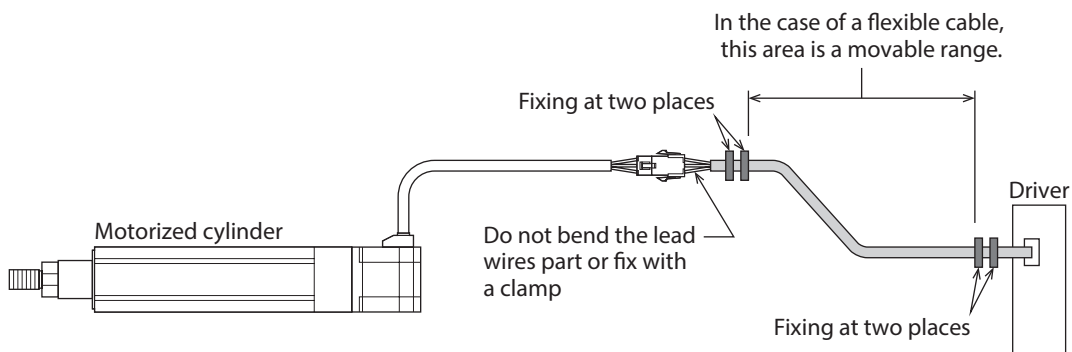



# 4 Preparation

This chapter explains the items you should check, as well as the name of each part.

## 4-1 Checking the product

Verify that the items listed below are included. Report any missing or damaged items to the Oriental Motor sales office from which you purchased the product.

When purchasing a motorized cylinder and driver package	When purchasing a motorized cylinder only
<ul style="list-style-type: none"> <li>• Motorized cylinder</li> <li>• Driver</li> <li>• Instructions and Precautions for Safe Use</li> <li>• Recovery Guide (Included with the models equipped with the <b>AZ</b> Series)</li> <li>• APPENDIX UL Standards *1</li> <li>• Connectors bag</li> <li>• Cable for motor *2</li> <li>• Cable for electromagnetic brake *2 (Included with electromagnetic brake types)</li> <li>• Cable for encoder *2 (Included with the models equipped with the <b>AZ</b> Series)</li> <li>• Varistor *3 (Included with the models equipped with the <b>AR</b> Series)</li> </ul>	<ul style="list-style-type: none"> <li>• Motorized cylinder</li> <li>• Instructions and Precautions for Safe Use</li> <li>• Recovery Guide (Included with the models equipped with the <b>AZ</b> Series)</li> <li>• APPENDIX UL Standards *1</li> <li>• Varistor *4 (Included with the models equipped with the <b>AR</b> Series)</li> </ul>

\*1 Included with products conform to the UL Standards.

\*2 When the product is included with a connection cable.

\*3 Included with the motorized cylinder equipped with the DC power input type motor with electromagnetic brake which are combined with the pulse input type driver.

\*4 Included with the motorized cylinder equipped with the DC power input type motor with electromagnetic brake.

## 4-2 How to identify the product model

Verify the model name of the purchased product against the model shown on the package label.  
Check the model name of the motorized cylinder against the model shown on the nameplate.

### ■ Motorized cylinder and driver package model

EAC 4 R W - E 15 - AZ M K D -1 - G  
 1 2 3 4 5 6 7 8 9 10 11 12

1	Series name	<b>EAC</b> : <b>EAC</b> Series
2	Cylinder size	<b>2</b> : 28 mm <b>4</b> : 42 mm <b>6</b> : 60 mm
3	Motor mounting direction	<b>R</b> : Parallel motor mounting type Blank: In-line motor mounting type
4	Guided shaft	<b>W</b> : With guided shafts Blank: Without a guided shaft
5	Ball screw lead	<b>D</b> : 12 mm <b>E</b> : 6 mm <b>F</b> : 3 mm
6	Stroke	<b>05</b> to <b>30</b> : 50 to 300 mm (in 50 mm unit)
7	Motor	<b>AZ</b> : <b>AZ</b> Series <b>AR</b> : <b>AR</b> Series

8	Motor type	<b>A:</b> Single shaft <b>M:</b> With electromagnetic brake
9	Power input	<ul style="list-style-type: none"> <li>Motorized cylinder equipped with the <b>AZ</b> Series <b>A:</b> Single-phase 100-120 VAC <b>C:</b> Single-phase, three-phase 200-240 VAC <b>K:</b> 24 VDC/48 VDC</li> <li>Motorized cylinder equipped with the <b>AR</b> Series <b>A:</b> Single-phase 100-120 VAC (Single-phase 100-115 VAC for the pulse input type) <b>C:</b> Single-phase 200-240 VAC (Single-phase 200-230 VAC for the pulse input type) <b>S:</b> Three-phase 200-230 VAC (For the pulse input type only) <b>K:</b> 24 VDC/48 VDC</li> </ul>
10	Driver type	<b>D:</b> Built-in controller type Blank: Pulse input type
11	Length of included cable	Number: Length of included connection cable (m) Blank: Without connection cable
12	Guided-shaft cover	<b>G:</b> With guided-shaft covers Blank: Without a guided-shaft cover

### ■ Motorized cylinder model

**EACM** **4** **R** **W** **E** **15** **AZ** **M** **K** - **G**  
 1      2    3    4    5    6    7    8    9    10

1	Series name	<b>EACM: EAC</b> Series
2	Cylinder size	<b>2:</b> 28 mm <b>4:</b> 42 mm <b>6:</b> 60 mm
3	Motor mounting direction	<b>R:</b> Parallel motor mounting type Blank: In-line motor mounting type
4	Guided shaft	<b>W:</b> With guided shafts Blank: Without a guided shaft
5	Ball screw lead	<b>D:</b> 12 mm <b>E:</b> 6 mm <b>F:</b> 3 mm
6	Stroke	<b>05 to 30:</b> 50 to 300 mm (in 50 mm unit)
7	Motor	<b>AZ:</b> <b>AZ</b> Series <b>AR:</b> <b>AR</b> Series
8	Motor type	<b>A:</b> Single shaft <b>M:</b> With electromagnetic brake
9	Motor power supply type	<b>K:</b> DC power input <b>C:</b> AC power input
10	Guided-shaft cover	<b>G:</b> With guided-shaft covers Blank: Without a guided-shaft cover

## 4-3 Names of parts

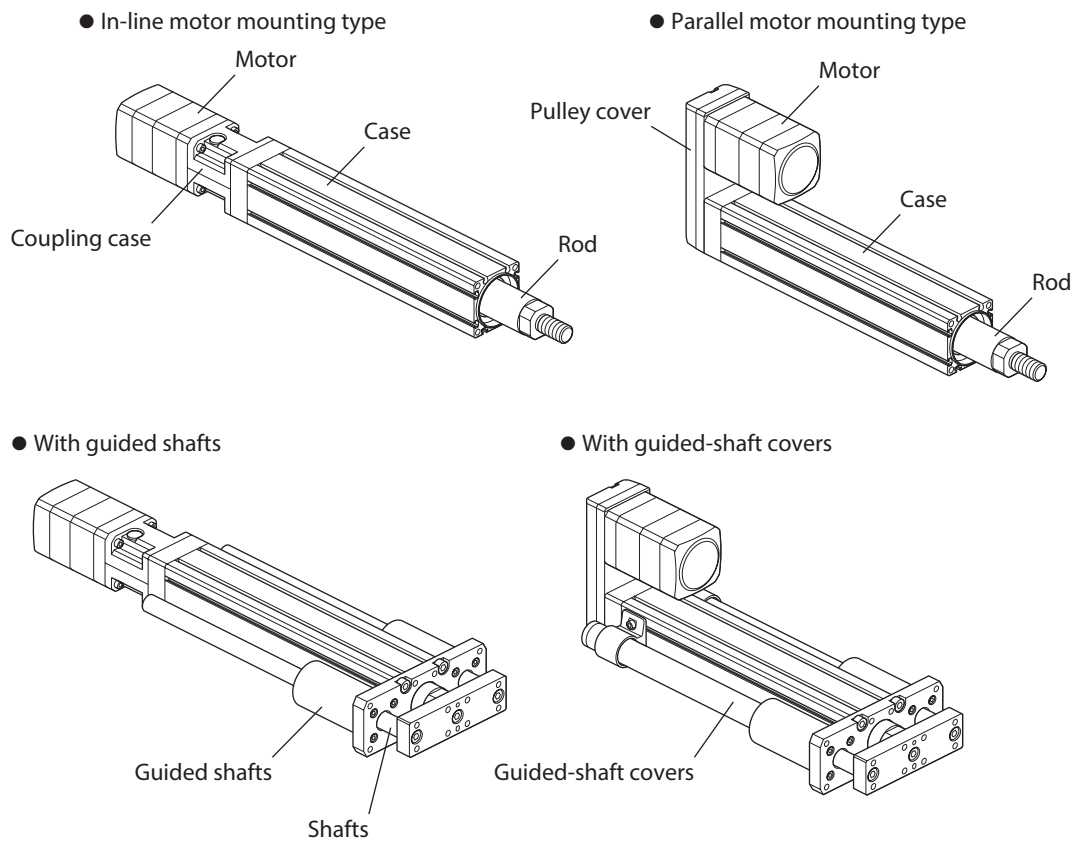

### ■ Mechanism of the parallel motor mounting type

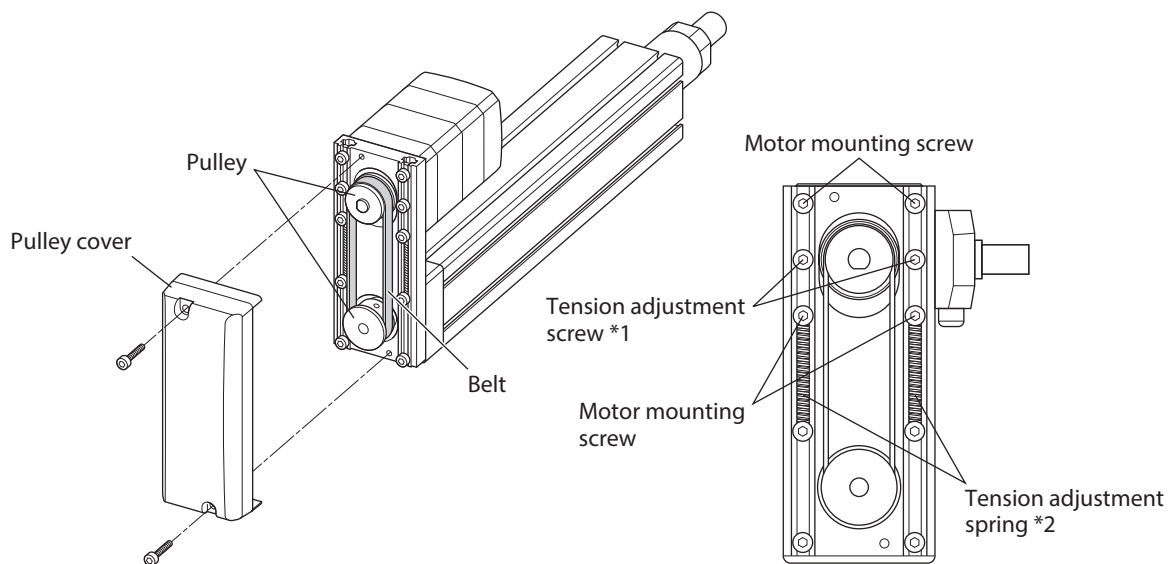

\*1 The motor is fixed in the position where the belt tension becomes optimum.

\*2 Springs for belt tension adjustment are installed.

## ■ Motor

### ● Motorized cylinder equipped with the AZ Series

#### EACM2

The following figure show models for the DC power input.

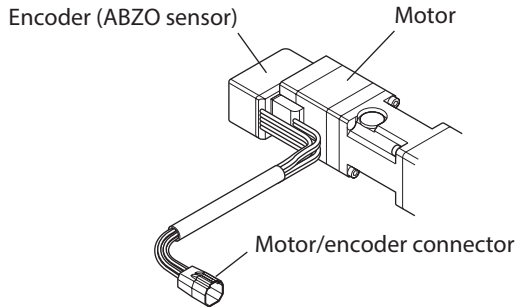

#### EACM4, EACM6

The following figure show models for the electromagnetic brake type and AC power input.

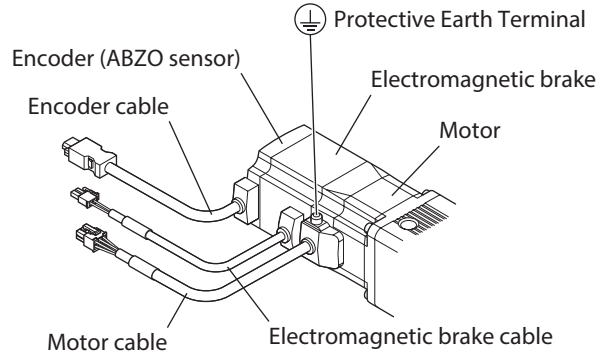

### ● Motorized cylinder equipped with the AR Series

The following figure show models for the electromagnetic brake type and AC power input.

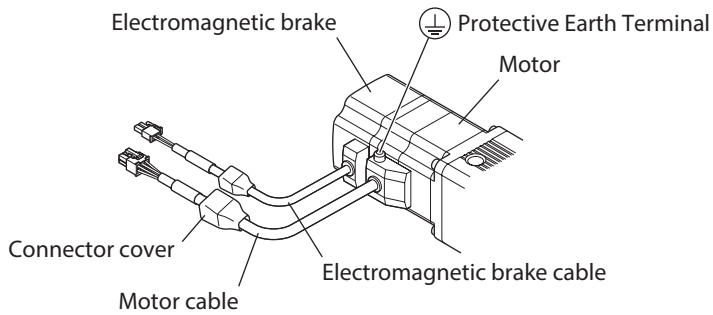

# 5 Installation

## 5-1 Location for installation

The motorized cylinder is designed and manufactured to be incorporated in equipment. Install them in a well-ventilated location that provides easy access for inspection. The location must also satisfy the following conditions.

- Inside an enclosure that is installed indoors (provide vent holes)
- Operating ambient temperature: 0 to +40 °C (+32 to +104 °F) (non-freezing)
- Operating ambient humidity 85 % or less (non-condensing)
- Area free of explosive atmosphere, toxic gas (such as sulfuric gas) or liquid
- Area not exposed to direct sun
- Area free of excessive amount of dust, iron particles or the like
- Area not subject to splashing water (rain, water droplets), oil (oil droplets), or other liquids
- Area free of excessive salt
- Area not subject to continuous vibrations or excessive shocks
- Area free of excessive electromagnetic noise (from welders, power machinery, etc.)
- Area free of radioactive materials, magnetic fields or vacuum
- 1,000 m (3,300 ft.) or lower above sea level.

### ■ If a motorized cylinder is installed in an environment where a magnetic field is generated

A magnetic sensor is built into the encoder (ABZO sensor). If the motorized cylinder is installed close to equipment which generates a strong magnetic field, the encoder (ABZO sensor) may break or malfunction. Make sure that the magnetic flux density on the surface of the encoder (ABZO sensor) does not exceed the values in the table. Allow more clearance around the encoder than specified in the table.

Manufacturing date of equipped motor	Cylinder model	Magnetic flux density
After October 2023	All	10 mT
Before September 2023	<b>EACM2</b>	2 mT *
	<b>EACM4, EACM6</b>	10 mT

\* When the magnetic flux density is exceeding 1 mT and 2 mT or less, use in an environment where the operating ambient temperature is exceeding 20 °C (68 °F) and 40 °C (104 °F) or less.

**Note** Do not install the motorized cylinder close to equipment which generates a strong magnetic field.

### ■ Install the EACM2 type equipped with the AZ Series

The encoder (ABZO sensor) of the **EACM2** type equipped with the **AZ** Series is easily affected by a magnetic field, so make sure the installation location. Allow more clearance around the encoder than specified in the table. For the manufacturing date of an equipped motor, check the nameplate on the motor.

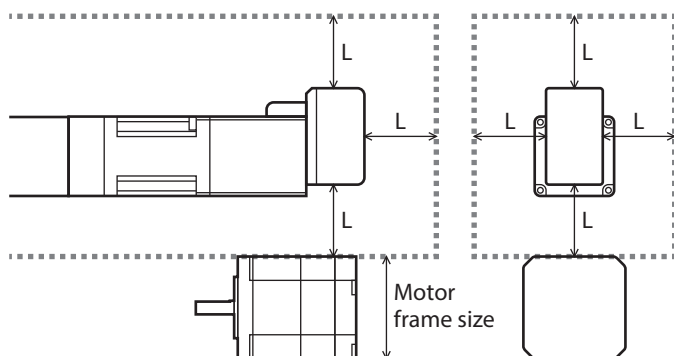

Manufacturing date of equipped motor	Distance from the ABZO sensor (L)
After October 2023	2 mm
Before September 2023	Motor frame size

## ■ Releasing the electromagnetic brake

When moving the rod of the electromagnetic brake type manually, connect the 24 VDC power supply for electromagnetic brake to release the electromagnetic brake.

**memo** If a cable for mini Driver is used, the electromagnetic brake cannot be released using a DC power supply. Refer to the operating manual of the mini Driver for how to release the electromagnetic brake.

### ● Specifications of a power supply for electromagnetic brake

Model	Voltage	Current capacity
<b>EACM2</b>	24 VDC $\pm 5\%$ *	0.05 A or more
<b>EACM4</b>		0.08 A or more
<b>EACM6</b>		0.25 A or more

\* If the distance between the motorized cylinder with an electromagnetic brake and the driver is extended to the following length, use a power supply of 24 VDC $\pm 4\%$ .

Motorized cylinder equipped with the **AZ** Series : 20 m (65.6 ft.)

Motorized cylinder equipped with the **AR** Series : 20 to 30 m (65.6 to 98.4 ft.)

### ● Releasing procedure

1. Connect the “electromagnetic brake cable” and “cable for electromagnetic brake.”
2. Connect the lead wires of the “cable for electromagnetic brake” to the 24 VDC power supply.  
Connect the white lead wire to the +24 VDC terminal, and the black lead wire to the GND terminal.
3. Turn on the 24 VDC power supply.  
The electromagnetic brake will be released and the rod will be able to move by hand.

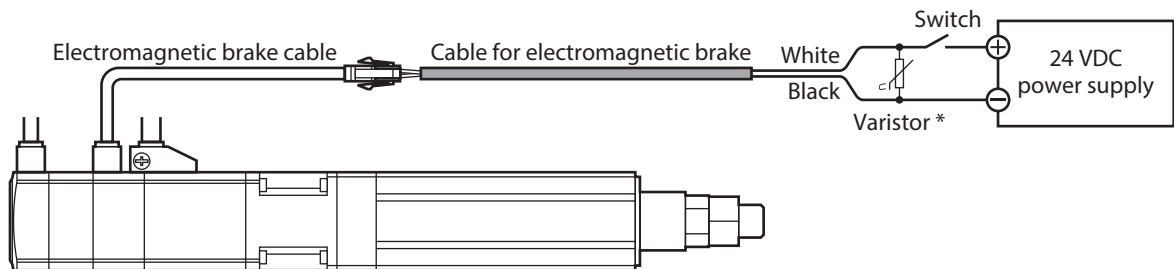

\* Be sure to connect the varistor to protect the contact of the switch or to prevent electrical noise.

Motorized cylinder equipped with the **AZ** Series : Recommended varistor: Z15D121 (SEMITEC Corporation)

Motorized cylinder equipped with the **AR** Series : Use the included varistor.

**Note** The lead wires of the “cable for electromagnetic brake” have polarities, so connect them in the correct polarities. If the lead wires are connected with their polarities reversed, the electromagnetic brake will not operate properly.

## 5-2 Installation method

The motorized cylinder can be installed in any direction. Taking account of vibration prevention as well as deflection of the motorized cylinder, install it on a metal surface of sufficient strength (thickness 10 mm or more). Install the motorized cylinder using the flange side or the side of the case.

### **⚠ WARNING**

Be sure to secure the motorized cylinder according to the screw size and tightening torque which are specified in this manual. Failure to do so may result in injury or damage to equipment.

### ■ Mounting plate

The thickness of the mounting plate described in the table is the minimum requirements for installation. If the accuracy is required, design the thickness of the mounting plate in consideration of the installation conditions such as load condition, rigidity, vibration and others.

Material	Aluminum
Thickness	10 mm or more

### ■ When a motorized cylinder is installed using the flange side

#### **Note**

When installing a motorized cylinder which stroke is equal to 150 mm or longer using the flange side, support the cylinder with a supporting table.

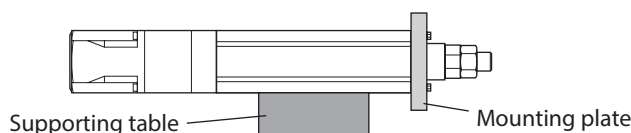

### ● When installing a motorized cylinder directly

Model	Screw size	Tightening torque
EACM2	M3	1 N·m (142 oz-in)
EACM4	M5	5 N·m (710 oz-in)
EACM6	M6	5 N·m (710 oz-in)

Model	Screw length from the mounting plate
EACM2	6 mm or less
EACM4	10 mm or less
EACM6	12 mm or less

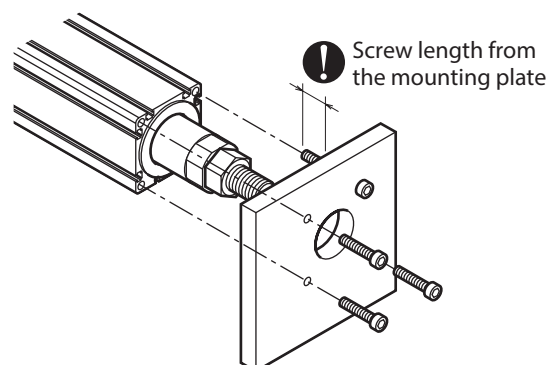

### ● When installing a motorized cylinder with guided shafts

Model	Screw size	Tightening torque
EACM2	M3	1 N·m (142 oz-in)
EACM4	M5	5 N·m (710 oz-in)
EACM6	M6	5 N·m (710 oz-in)

Model	Screw length from the mounting plate
EACM2	6 mm or less
EACM4	10 mm or less
EACM6	12 mm or less

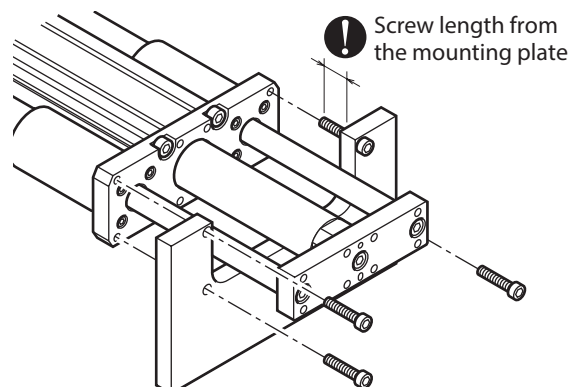

#### **Note**

Do not hold the guided-shaft cover when carrying or installing a motorized cylinder with guided shafts. Doing so may damage the guided-shaft cover.

■ **When a motorized cylinder is installed using the side of the case**

**Note** Install the motorized cylinder so that the cable or encoder (ABZO sensor) does not contact with the mounting plate. Also, make the mounting plate shorter than the length of the case.

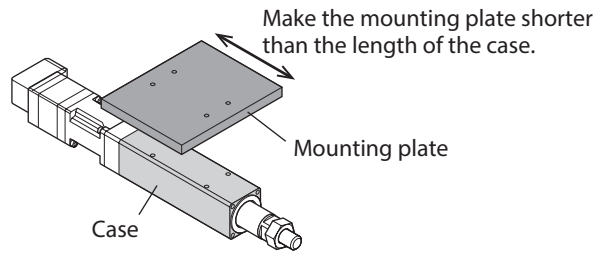

**memo** For **EACM2**, mounting holes are provided on only one side of the case.  
For **EACM4** and **EACM6**, grooves for mounting nuts are provided on three sides of the case.

**EACM2**

Model	Screw size	Tightening torque	Screw length from the mounting plate
<b>EACM2</b>	M3	1 N·m (142 oz-in)	6 mm or less

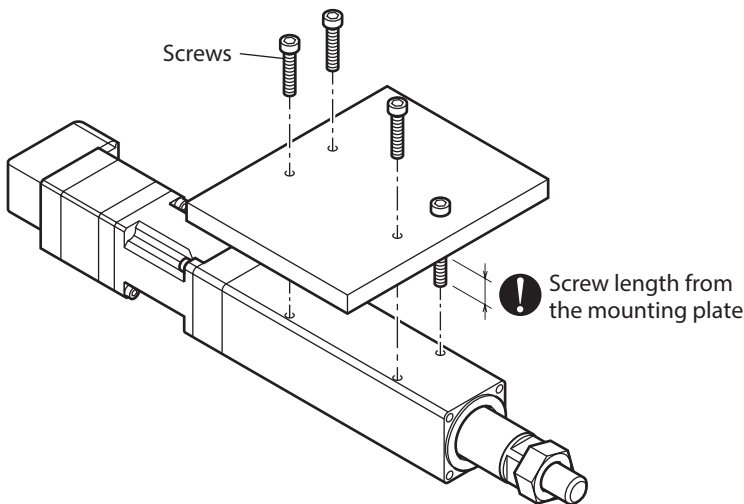

**EACM4, EACM6**

1. Insert the nuts into the grooves on the side face of the motorized cylinder.

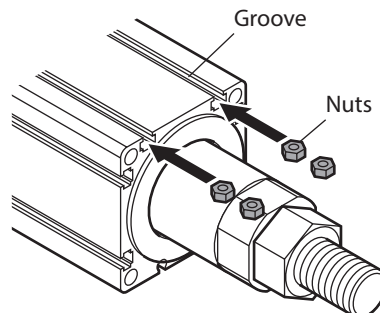



2. Secure the mounting plate to the nuts with screws.

Model	Screw size	Tightening torque	Screw length from the mounting plate
<b>EACM4</b>	M3	1 N·m (142 oz-in)	4.2 mm or less
<b>EACM6</b>	M4	2.4 N·m (340 oz-in)	5.8 mm or less

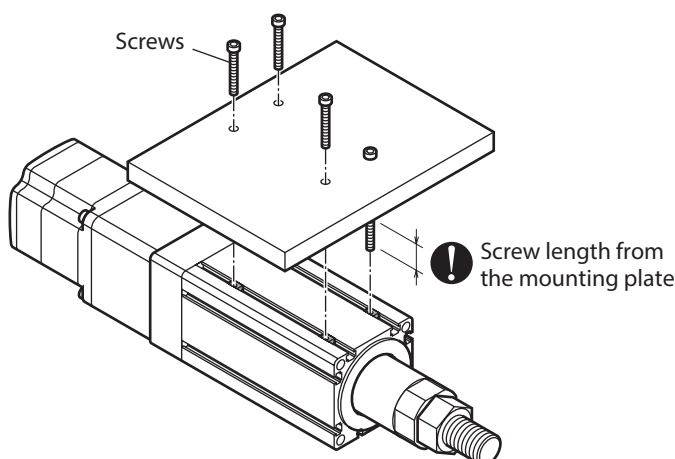

### 5-3 Changing the motor cable outlet direction

The motor cable outlet direction can be changed according to the space of equipment.

#### **⚠ WARNING**

- When changing the motor cable outlet direction, remove the load, and perform in a state where the motorized cylinder is placed in a horizontal position. Doing the operation in a vertical condition may allow the moving part to fall, leading to injury or mechanical damage.
  - If the motor mounting screws are removed in a state where the motorized cylinder is installed vertically, the motor may rotate rapidly. Thereby, fingers may be caught in the product or the cable may be disconnected.
- Set the home again after mounting a motor. If the motorized cylinder is operated without setting the home again, the moving part may move to unexpected directions or run at unexpected speeds, leading to injury or mechanical damage.
  - The moving part of the motorized cylinder may hit with the mechanical stopper.
  - The load may hit with other equipment.
- Be sure to secure the coupling with the specified tightening torque. Unless it is secured with the specified torque, the ball screw may rotate idly, leading to injury or mechanical damage.
  - When the motorized cylinder is used in a vertical condition, the load may fall.
  - When the motorized cylinder is used in a horizontal condition, the moving part of the motorized cylinder may hit with the mechanical stopper. Also, the load may hit with other equipment.

### ■ In-line motor mounting type

1. Remove the cap, and loosen the coupling fixing screw.

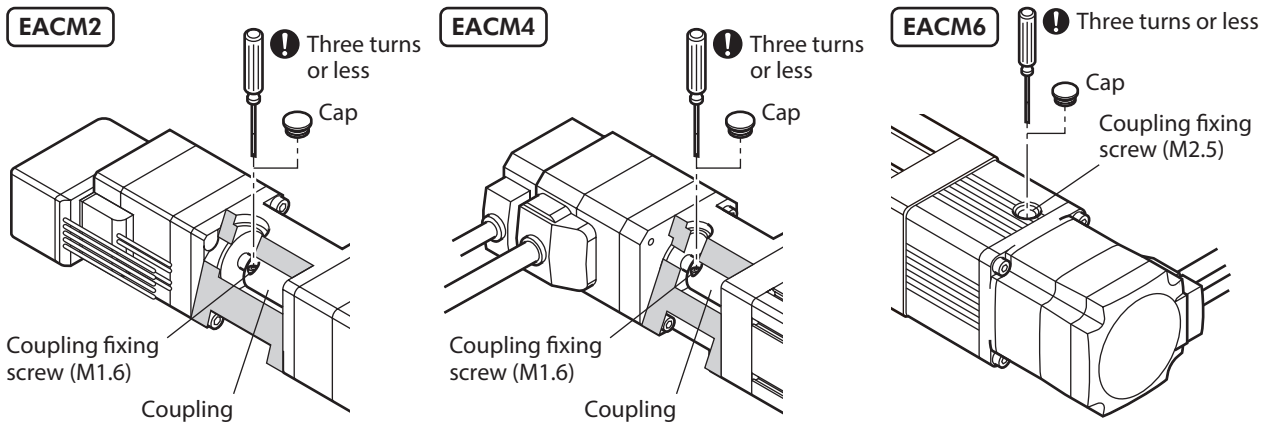

- memo**
- When loosening the coupling fixing screw, do not insert the tool diagonally.
  - Do not use the ball-end hex key.
  - To prevent the coupling fixing screw from falling off, keep three turns or less when turning the screw.

2. Remove the motor mounting screws, and dismount the motor.

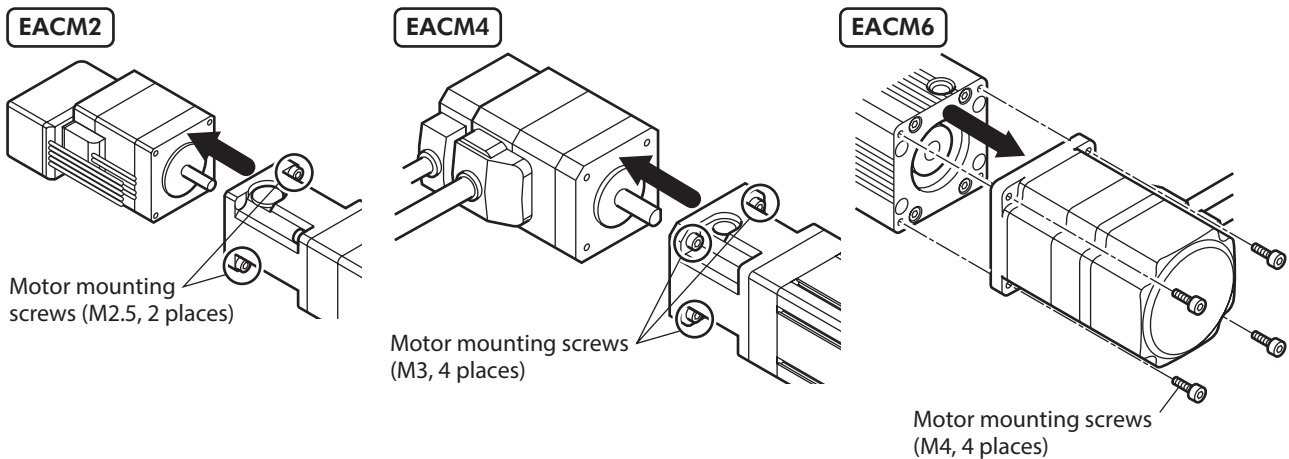

- Note** Be sure to remove the motor when changing the motor cable outlet direction. If the motor is rotated while the mounting surface of the motor and actuator are in contact, the motor may not be removed.

3. Change the cable outlet direction, and mount the motor.

Mount the motor according to the procedure opposite of dismantling it.

Refer to the table for the tightening torque of the coupling fixing screw and motor mounting screws.

Model	Coupling fixing screw		Motor mounting screws	
	Screw size	Tightening torque	Screw size	Tightening torque
<b>EACM2</b>	M1.6	0.25 N·m (35 oz-in)	M2.5	0.5 N·m (71 oz-in)
<b>EACM4</b>	M1.6	0.25 N·m (35 oz-in)	M3	1 N·m (142 oz-in)
<b>EACM6</b>	M2.5	1 N·m (142 oz-in)	M4	2.4 N·m (340 oz-in)

- memo** Use a tool capable of controlling the torque when tightening the coupling fixing screw.

4. After mounting the motor, set the home again.

## ■ Parallel motor mounting type

The cable outlet direction can be changed to one of three directions.

1. Remove the pulley cover fixing screws, and detach the pulley cover.

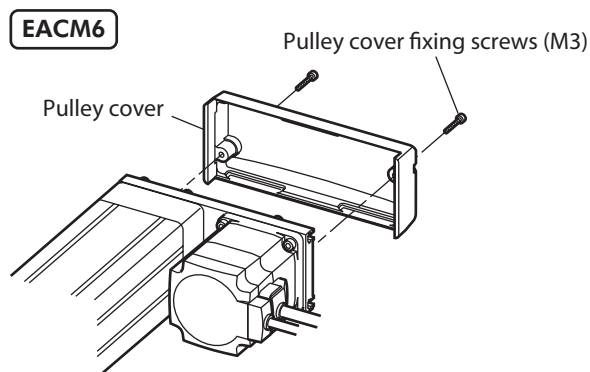
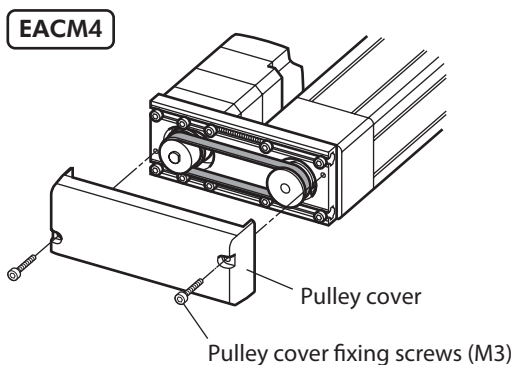

2. Remove the motor mounting screws, and dismount the motor.

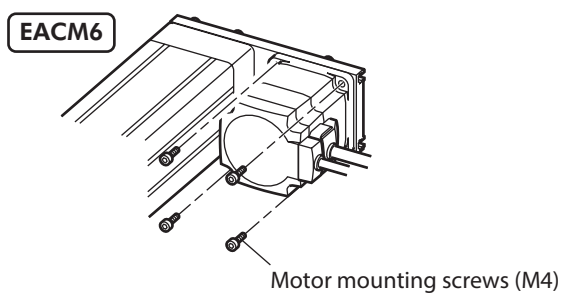
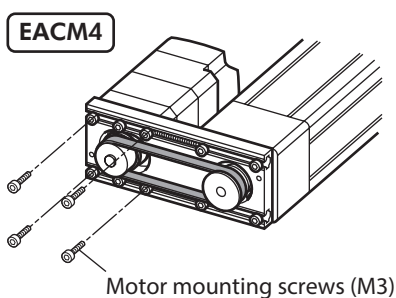

### Note

- Be sure to remove the motor when changing the motor cable outlet direction. If the motor is rotated while the mounting surface of the motor and actuator are in contact, the motor may not be removed.
- Do not loosen or remove the screws other than the motor mounting screws.

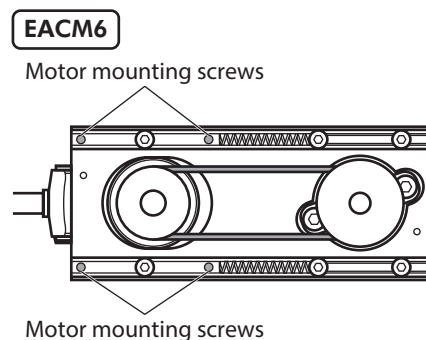
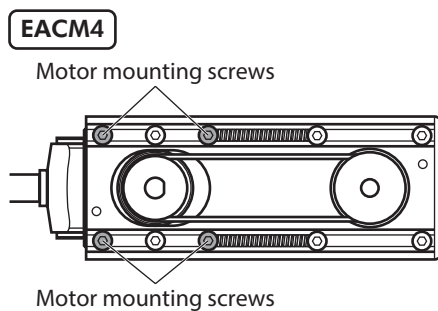

3. Change the cable outlet direction, and mount the motor to tentatively fix the motor mounting screws. Tentatively fix the screws in a degree to be able to move the motor when touching it.

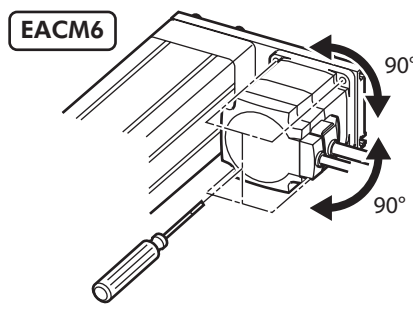
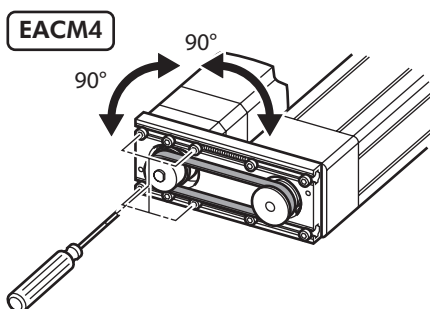

- Loosen the tension adjustment screws.  
When loosening the screws, tension of the belt will be adjusted properly by the strength of springs.

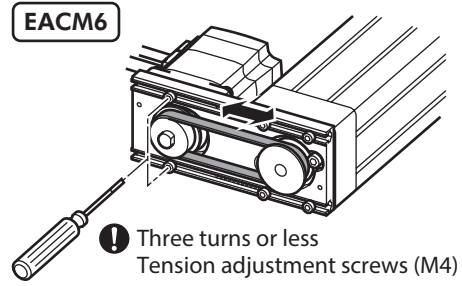
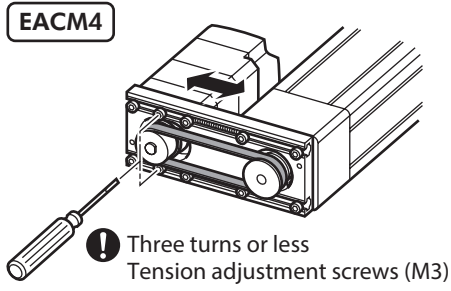

**memo** To prevent the tension adjustment screws from falling off, keep three turns or less when turning the screw.

- Tighten the motor mounting screws with pressing the motor in the direction of arrow so that the motor does not tilt.

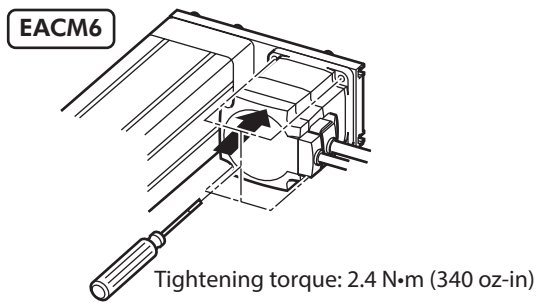
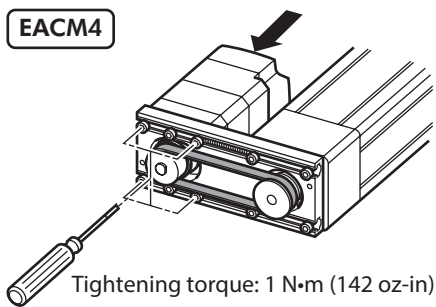

- Tighten the tension adjustment screws.

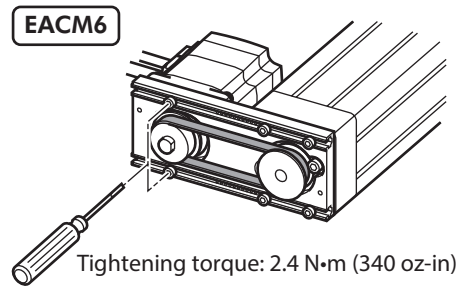
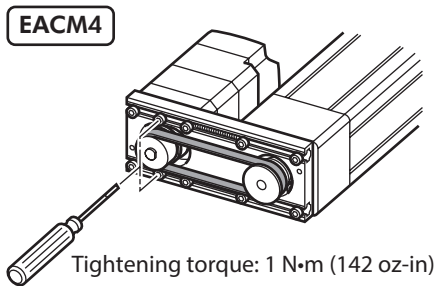

- Attach the pulley cover, and tighten the screws.  
Tightening torque: 1 N·m (142 oz-in)
- After mounting the motor, set the home again.

## 5-4 How to install a load

### ■ Motorized cylinder without a guided shaft

Install a load using the screw on the rod end and the nut (included).

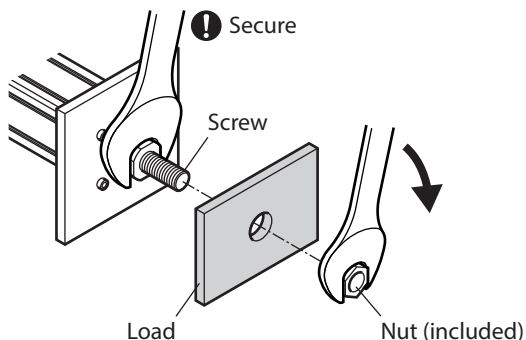

### ■ Motorized cylinder with guided shafts

Install a load using the load mounting holes on the rod end.

Values of the tightening torque are recommended.

Tighten with an appropriate torque according to the design conditions of the load.

Model	Screw size	Tightening torque	Screw length from the load
EACM2	M3	1 N·m (142 oz-in)	6 mm or less
EACM4	M5	5 N·m (710 oz-in)	10 mm or less
EACM6	M6	5 N·m (710 oz-in)	12 mm or less

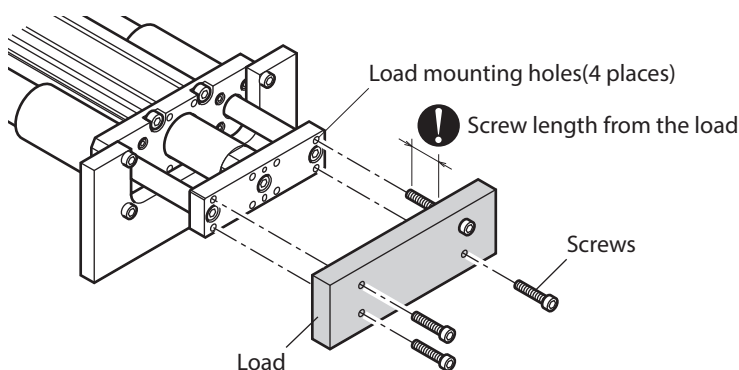

#### Positioning pin holes for load on rod end

There are two positioning pin holes on the rod end.

If installation repeatability is required when a load is installed, use these positioning pin holes.

#### EACM2



Positioning pin holes

#### EACM4, EACM6

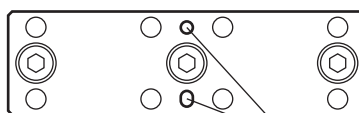

Positioning pin holes

Model	Pin hole diameter	Pin hole depth
EACM2, EACM4	$\varnothing 3 \begin{smallmatrix} +0.01 \\ 0 \end{smallmatrix}$ mm	4 mm
EACM6	$\varnothing 4 \begin{smallmatrix} +0.012 \\ 0 \end{smallmatrix}$ mm	4 mm

#### Note

Be sure to secure the positioning pins to a load side. Securing the positioning pins to the rod may damage the motorized cylinder due to impact or an excessive moment of inertia.

# 6 Connection

## 6-1 Connecting the driver

For details about the connection method of the driver, refer to the operating manual of the driver.

## 6-2 Grounding

- memo** • When multiple actuators of AC power input type are used in combination, provide protective earth for each actuator.
- Do not share the grounding wire with a welder or power equipment.

### ■ AZ Series

Protective earth is not required for DC power input type actuators. Ground the functional earth terminal (M4) if necessary.

AC power input type actuators can be grounded by connecting the protective earth wire of the cable for motor to the Protective Earth Terminal of the driver. However, if grounding the protective earth wire of the cable for motor does not satisfy the grounding resistance required by the applicable standard of the equipment, the Protective Earth Terminal of the motor must also be grounded.

#### 1) Grounding the protective earth wire of the motor

Connect the protective earth wire of the cable for motor to the Protective Earth Terminal of the driver.

Equipped motor	AZ Series	
Cable type	Connection cable	Flexible connection cable
Conductor wire size	AWG18 (0.75 mm <sup>2</sup> )	AWG18 (0.75 mm <sup>2</sup> )
Maximum conductor resistance	21.8 Ω/km	25.6 Ω/km
Tightening torque	1.2 N·m (170 oz-in)	

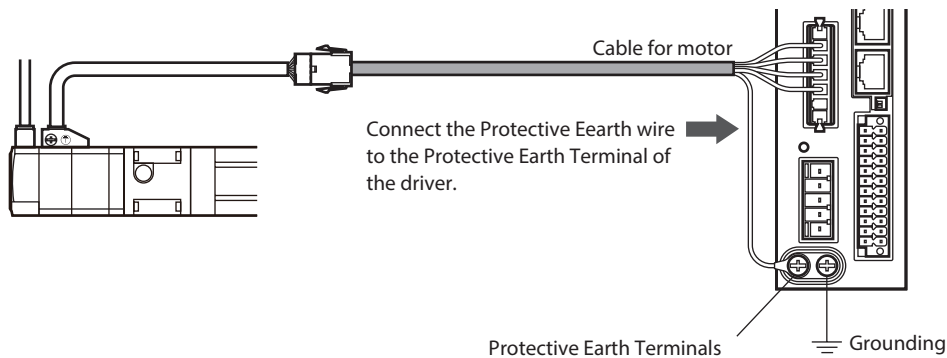

- memo** Ground the Protective Earth Terminal of the motor if the grounding resistance required by the applicable standard of the equipment is not satisfied.

## 2) Grounding the Protective Earth Terminal of the motor

Ground the Protective Earth Terminal of the motor. Use a round terminal when grounding, and make sure to secure with a screw and washer.

A grounding wire and a crimp terminal are not included.

- Grounding wire: AWG 18 (0.75 mm<sup>2</sup>) or thicker
- Screw size of Protective Earth Terminal: M4
- Tightening torque: 1.2 N·m (170 oz-in)

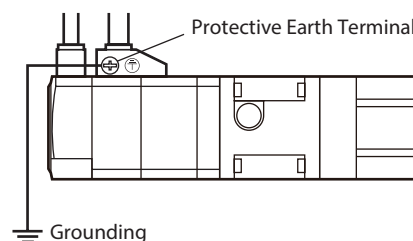

### ■ AR Series

Protective earth is not required for DC power input type actuators.

Ground the functional earth terminal (M4) if necessary.

Ground the Protective Earth Terminal of the motor for AC power input type actuators.

Use a round terminal when grounding, and make sure to secure with a screw and washer.

A grounding wire and a crimp terminal are not included.

- Grounding wire: AWG 18 (0.75 mm<sup>2</sup>) or thicker
- Screw size of Protective Earth Terminal: M4
- Tightening torque: 1.2 N·m (170 oz-in)

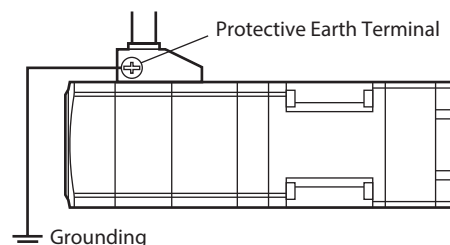

# 7 Maintenance

This chapter explains the maintenance items in order to operate motorized cylinder safely and efficiently. If an abnormal condition is noted on the motorized cylinder, discontinue any use and contact your nearest Oriental Motor sales office.

## 7-1 Inspection items and timing

If the motorized cylinder is operated eight hours a day, perform maintenance according to the applicable period specified in the table. Reduce maintenance intervals accordingly if the operating rate is high such as continuous operation for 24 hours.

Maintenance timing	External inspection	External cleaning
When operated for the first time	○	—
Six months after initial operation	○	—
Every six months thereafter	○	—
As needed	—	○

### ■ External inspection

Check the items specified in table.

Item	What to check	Action if problem is found
Motorized cylinder	<ul style="list-style-type: none"> <li>• Check if any of the screws having installed the motorized cylinder is loose.</li> <li>• Check if any of the screws having installed a load is loose.</li> <li>• Check if any of the screws having installed a motor is loose.</li> </ul>	Tighten the screws securely.
Connector, Cable	<ul style="list-style-type: none"> <li>• Check if a damage or stress is applied on the cable.</li> <li>• Check if the connection part between the motorized cylinder and driver is loose.</li> </ul>	<ul style="list-style-type: none"> <li>• Replace the cable.</li> <li>• Connect the connector again.</li> </ul>
Operation	Check if an unusual noise or vibration is generated from a bearing part (ball bearings).	Check the load mounting condition and operating speed.

### External cleaning

- Wipe off any dirt and stains using a soft cloth. To remove stubborn stains, wipe the area using a soft cloth moistened with neutral detergent.
- Do not apply compressed air. Dust may enter through gaps.
- Do not use petroleum solvents, since they will damage the coated surface.

## 7-2 Applying grease

Refer to the re-greasing interval in the table, and apply new grease after wiping off the old grease on the rod with a soft cloth.

### CAUTION

Wear protective goggles when applying grease. Pay attention to safety and handle the grease carefully by following the instructions provided with that product. If grease gets into the eyes or comes in contact with the skin, immediately flush the area thoroughly with water.

Re-greasing interval	Type of grease
<ul style="list-style-type: none"> <li>• Every 500 km (310 mi.) in mileage</li> <li>• When the color of the grease is changed to brown or the gloss of the grease is lost.</li> </ul>	Multemp SRL (KYODO YUSHI CO., LTD.)

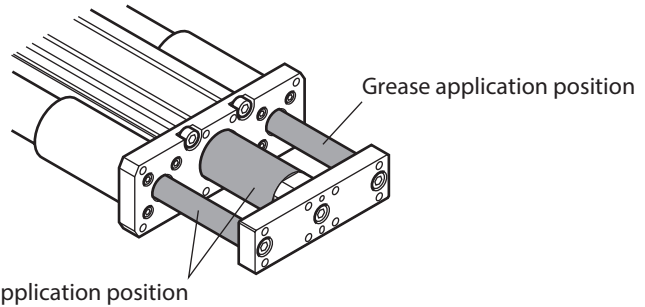
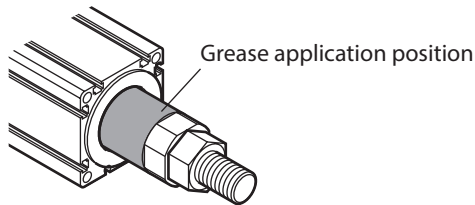

## 7-3 Checking the belt (Parallel motor mounting type)

Detach the pulley cover, and check the belt condition according to the items in the table. As the result of checking, replace the belt if abnormality is detected. Refer to p.25 for how to replace the belt.

Inspection interval	Every 500 km (310 mi.) in mileage
Inspection item	<ul style="list-style-type: none"> <li>• No crack on the belt rubber</li> <li>• No tooth chip on the belt</li> <li>• No abnormal wear on the tooth cloth of the belt</li> </ul>

### Checking method

This section explains about the **EACM4** type as an example.

1. Remove the pulley cover fixing screws, and detach the pulley cover.

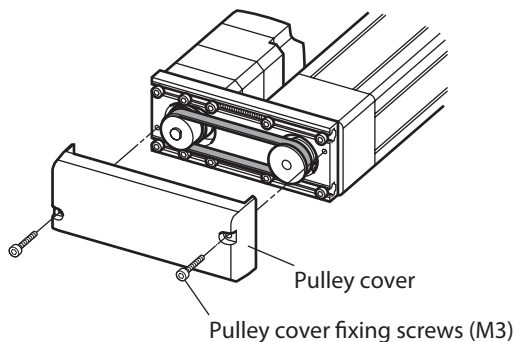



2. Check the belt condition. And check the belt does not detach or protrude from the pulley.

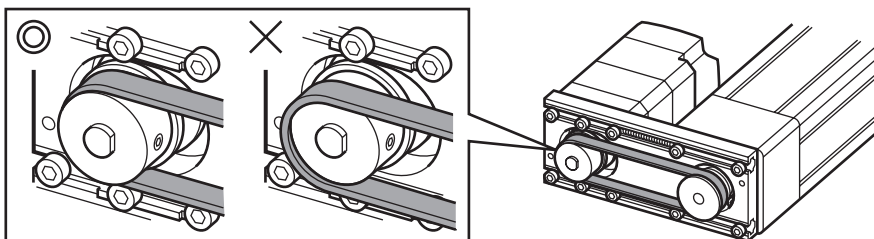

3. Attach the pulley cover, and tighten the screws.  
Tightening torque: 1 N·m (142 oz-in)

## 7-4 Adjusting the belt tension and replacing the belt

Adjust the belt tension of the parallel motor mounting type, or replace the belt.

### **⚠ WARNING**

- When adjusting the belt tension or replacing the belt, remove the load, and perform in a state where the motorized cylinder is placed in a horizontal position. Doing the operation in a vertical condition may allow the moving part to fall, leading to injury or mechanical damage.
- Set the home again after mounting a motor. If the motorized cylinder is operated without setting the home again, the moving part may move to unexpected directions or run at unexpected speeds, leading to injury or mechanical damage.
  - The moving part of the motorized cylinder may hit with the mechanical stopper.
  - The load may hit with other equipment.

### ■ Belt for maintenance

For the belt for maintenance, contact your nearest Oriental Motor sales office.

Model	Belt model
<b>EACM4</b>	<b>LS-LVCS2M060186</b>
<b>EACM6</b>	<b>LS-LVCS3M080252</b>

### ■ Working procedure

This section explains about the **EACM4** type as an example. With the **EACM6** type, the motor mounting screws are located in the rear side of the motor.

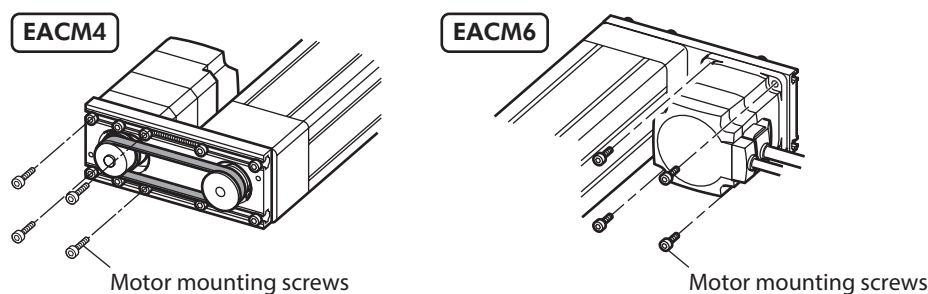

1. Remove the pulley cover fixing screws, and detach the pulley cover.

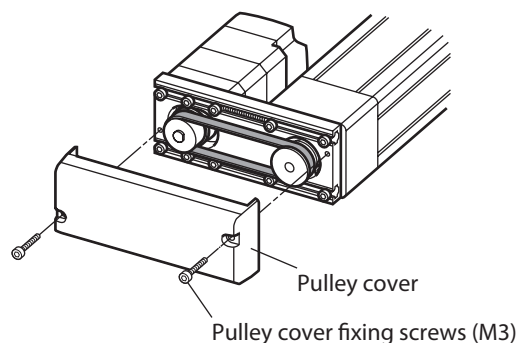

2. Loosen the motor mounting screws.

Model	Screw size
<b>EACM4</b>	M3
<b>EACM6</b>	M4

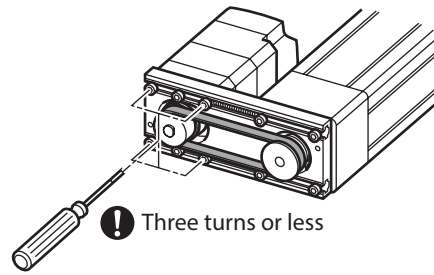

**memo** To prevent the motor mounting screw from falling off, keep three turns or less when turning the screw.

3. Loosen the tension adjustment screws.  
When loosening the screws, tension of the belt will be adjusted properly by the strength of springs.

Model	Screw size
<b>EACM4</b>	M3
<b>EACM6</b>	M4

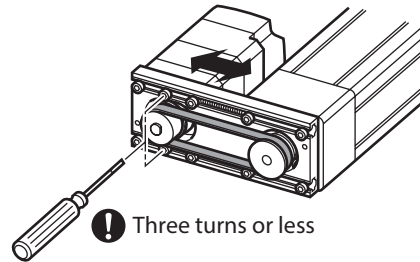

**memo** To prevent the tension adjustment screw from falling off, keep three turns or less when turning the screw.

4. When replacing the belt, remove it while pressing the motor to the cylinder side. In addition, even when installing a new belt, do so while pressing the motor.

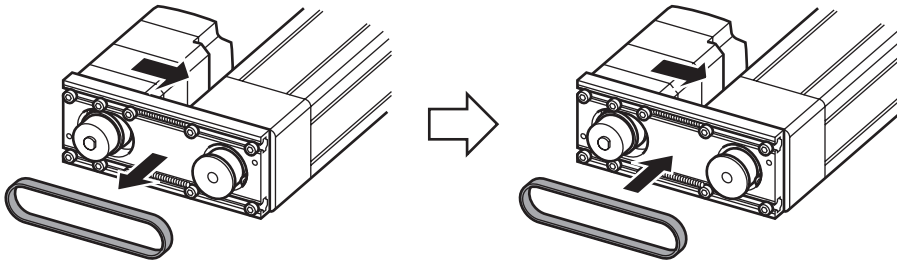

5. Tighten the motor mounting screws with pressing the motor in the direction of arrow so that the motor does not tilt.

Model	Tightening torque
<b>EACM4</b>	1 N·m (142 oz-in)
<b>EACM6</b>	2.4 N·m (340 oz-in)

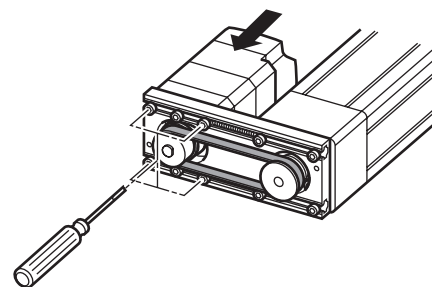

6. Tighten the tension adjustment screws.

Model	Tightening torque
<b>EACM4</b>	1 N·m (142 oz-in)
<b>EACM6</b>	2.4 N·m (340 oz-in)

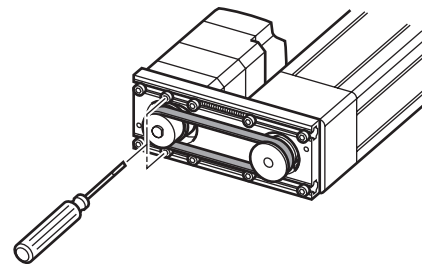

7. Attach the pulley cover, and tighten the screws.  
Tightening torque: 1 N·m (142 oz-in)
8. After mounting the motor, set the home again.

## 7-5 Replacing the motor

### **⚠ WARNING**

- When replacing the motor, remove the load, and perform in a state where the motorized cylinder is placed in a horizontal position. Doing the operation in a vertical condition may allow the moving part to fall, leading to injury or mechanical damage.
  - If the motor mounting screws are removed in a state where the motorized cylinder is installed vertically, the motor may rotate rapidly. Thereby, fingers may be caught in the product or the cable may be disconnected.
- Set the home again after mounting a motor. If the motorized cylinder is operated without setting the home again, the moving part may move to unexpected directions or run at unexpected speeds, leading to injury or mechanical damage.
  - The moving part of the motorized cylinder may hit with the mechanical stopper.
  - The load may hit with other equipment.
- Be sure to secure the coupling or pulley with the specified tightening torque. Unless it is secured with the specified torque, the ball screw may rotate idly, leading to injury or mechanical damage.
  - When the motorized cylinder is used in a vertical condition, the load may fall.
  - When the motorized cylinder is used in a horizontal condition, the moving part of the motorized cylinder may hit with the mechanical stopper. Also, the load may hit with other equipment.
- If the motor for the motorized cylinder equipped with the **AZ** Series is replaced, restore using the recovery data file. Replacing the motor only will not set the optimal parameters to the driver, so the motorized cylinder may move to unexpected directions or run at unexpected speeds, leading to injury or damage to equipment. For details, refer to the **AZ** Series OPERATING MANUAL Function Edition.

### ■ In-line motor mounting type

Refer to "In-line motor mounting type" on p.18, replace the motor. If the motor for the motorized cylinder equipped with the **AZ** Series was replaced, set the home again after restoring with the recovery data file.

### ■ Parallel motor mounting type

This section explains about the **EACM4** type as an example. With the **EACM6** type, the motor mounting screws are located in the rear side of the motor.

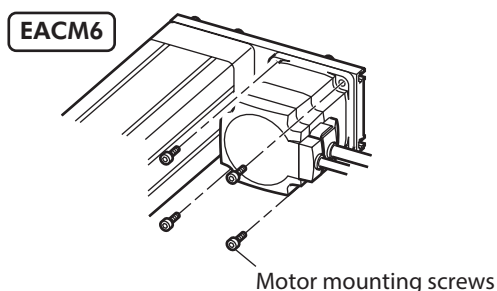
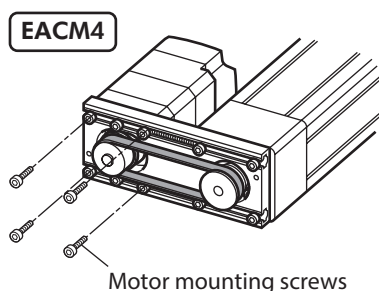

### ● Pulley for maintenance

If the motor of the parallel motor mounting type is replaced, purchase the pulley together with the motor. For details, contact your nearest Oriental Motor sales office.

Model	Pulley model
<b>EACM4</b>	<b>LS-LSPTP1709</b>
<b>EACM6</b>	<b>LS-LSPTP1710</b>

● **Replacement procedure**

1. Remove the pulley cover fixing screws, and detach the pulley cover.

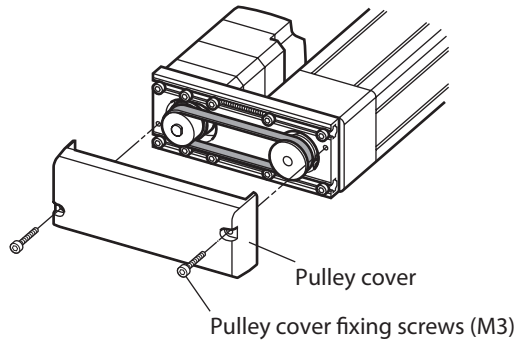

2. Remove the motor mounting screws.

Model	Screw size
<b>EACM4</b>	M3
<b>EACM6</b>	M4

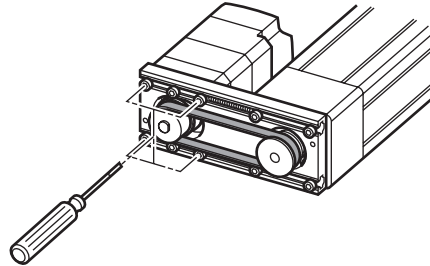

3. Dismount the motor and remove the belt.

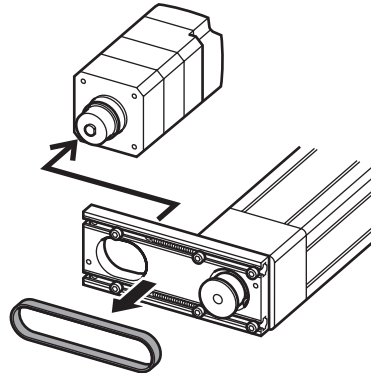

4. Install the pulley for maintenance to the new motor, and tighten the screws.

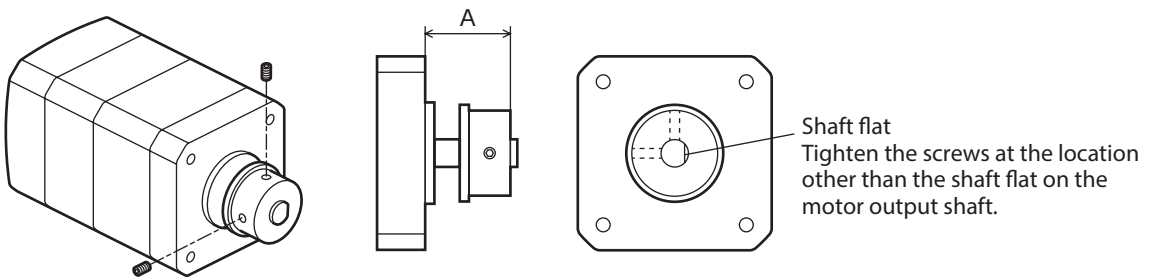

Model	A	Screw size	Tightening torque
<b>EACM4</b>	18.5 mm	M3	0.8 N·m (113 oz-in)
<b>EACM6</b>	20.5 mm	M4	1.7 N·m (241 oz-in)

5. Mount the motor and install the belt, and tentatively fix the motor mounting screws. Tentatively fix the screws in a degree to be able to move the motor when touching it.

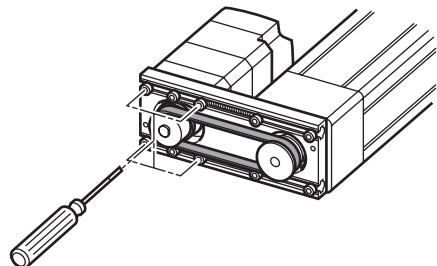

6. Loosen the tension adjustment screws.  
When loosening the screws, tension of the belt will be adjusted properly by the strength of springs.

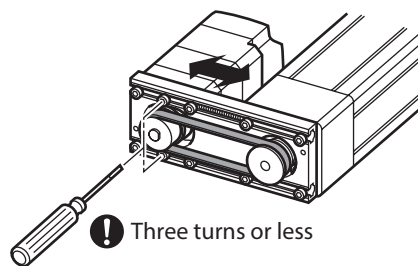

**memo** To prevent the tension adjustment screws from falling off, keep three turns or less when turning the screw.

7. Tighten the motor mounting screws with pressing the motor in the direction of arrow so that the motor does not tilt.

Model	Tightening torque
<b>EACM4</b>	1 N·m (142 oz-in)
<b>EACM6</b>	2.4 N·m (340 oz-in)

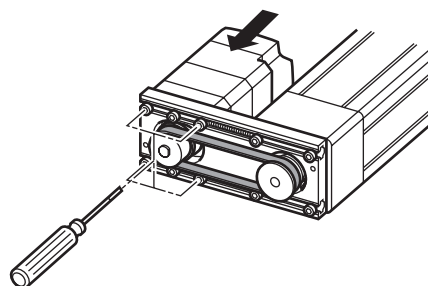

8. Tighten the tension adjustment screws.

Model	Tightening torque
<b>EACM4</b>	1 N·m (142 oz-in)
<b>EACM6</b>	2.4 N·m (340 oz-in)

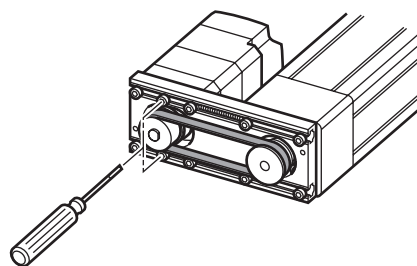

9. Attach the pulley cover, and tighten the screws.  
Tightening torque: 1 N·m (142 oz-in)
10. After mounting the motor, set the home again.  
If the motor for the motorized cylinder equipped with the **AZ** Series was replaced, set the home again after restoring with the recovery data file.

## 7-6 Warranty

Check on the Oriental Motor Website for the product warranty.

## 7-7 Disposal

Dispose the product correctly in accordance with laws and regulations, or instructions of local governments.

# 8 Standards, general specifications

## 8-1 Standards

### ■ Actuators equipped with the AZ Series

#### ● UL Standards, CSA Standards

For recognition information about UL Standards of the motor with which the actuator is equipped, check the "APPENDIX UL Standards" of product.

#### ● CE Marking / UKCA Marking

- EU Low Voltage Directive / UK Electrical Equipment (Safety) Regulation  
The AC input type motor with which the actuator is equipped is affixed with the marks under the EU Low Voltage Directive / UK Electrical Equipment (Safety) Regulation.
- EU EMC Directive / UK EMC Regulation  
The EMC test is conducted in a state where the equipped motor is connected to the driver. The driver combined with the motorized cylinder complies with the EMC Directive/Regulations. Refer to the operating manual of the driver for details.
- EU RoHS Directive / UK RoHS Regulation  
This product does not contain the substances exceeding the restriction values.

#### ● Machinery Directive

The motorized cylinder and driver are designed and manufactured to be incorporated in general industrial equipment, and a Declaration of Incorporation of Partly Completed Machinery is issued with them according to the Machinery Directive.

### ■ Actuator equipped with the AR Series

#### ● UL Standards, CSA Standards

For recognition information about UL Standards of the motor with which the actuator is equipped, check the "APPENDIX UL Standards" of each product.

#### ● CE Marking

- Low Voltage Directive  
The AC input type motor with which the actuator is equipped is affixed with the CE Marking under the Low Voltage Directive.
- EMC Directive  
The EMC test is conducted in a state where the equipped motor is connected to the driver. The driver combined with the motorized cylinder complies with the EMC Directive. Refer to the operating manual of the driver for details.
- RoHS Directive  
This product does not contain the substances exceeding the restriction values.

#### ● Machinery Directive

The motorized cylinder and driver are designed and manufactured to be incorporated in general industrial equipment, and a Declaration of Incorporation of Partly Completed Machinery is issued with them according to the Machinery Directive.

## 8-2 Specifications

Check on the Oriental Motor Website for the product specifications.

## 8-3 General specifications

### ■ Installation conditions

The product described in this manual is designed and manufactured to be incorporated in general industrial equipment.

Power input	DC power supply	AC power supply
Over voltage category	II	
Protection against electric shock	Class III	Class I
Pollution degree	2	3
Degree of protection	-	
Noise level	72 dB	

### ■ Environmental conditions

	Operation environment	Storage environment, shipping environment
Ambient temperature	0 to +40 °C (+32 to +104 °F) (non-freezing)	-20 to +60 °C (-4 to +140 °F) (non-freezing)
Ambient humidity	85 % or less (non-condensing)	
Altitude	Up to 1,000 m (3,300 ft.) above sea level	Up to 3,000 m (10,000 ft.) above sea level

- Unauthorized reproduction or copying of all or part of this Manual is prohibited.  
If a new copy is required to replace an original manual that has been damaged or lost, please contact your nearest Oriental Motor sales office.
- Oriental Motor shall not be liable whatsoever for any problems relating to industrial property rights arising from use of any information, circuit, equipment or device provided or referenced in this manual.
- Characteristics, specifications and dimensions are subject to change without notice.
- While we make every effort to offer accurate information in the manual, we welcome your input. Should you find unclear descriptions, errors or omissions, please contact your nearest Oriental Motor sales office.
- **Orientalmotor** and ABZO sensor are registered trademarks or trademarks of Oriental Motor Co., Ltd., in Japan and other countries.

Other product names and company names mentioned in this manual may be registered trademarks or trademarks of their respective companies and are hereby acknowledged. The third-party products mentioned in this manual are recommended products, and references to their names shall not be construed as any form of performance guarantee. Oriental Motor is not liable whatsoever for the performance of these third-party products.

© Copyright ORIENTAL MOTOR CO., LTD. 2015

Published in February 2024

- Please contact your nearest Oriental Motor office for further information.

ORIENTAL MOTOR U.S.A. CORP.  
Technical Support Tel:800-468-3982  
8:30am EST to 5:00pm PST (M-F)

ORIENTAL MOTOR (EUROPA) GmbH  
Schiesstraße 44, 40549 Düsseldorf, Germany  
Technical Support Tel:00 800/22 55 66 22

ORIENTAL MOTOR (UK) LTD.  
Unit 5 Faraday Office Park, Rankine Road,  
Basingstoke, Hampshire RG24 8QB UK  
Tel:+44-1256347090

ORIENTAL MOTOR (FRANCE) SARL  
Tel:+33-1 47 86 97 50

ORIENTAL MOTOR ITALIA s.r.l.  
Tel:+39-02-93906347

ORIENTAL MOTOR ASIA PACIFIC PTE. LTD.  
Singapore  
Tel:1800-842-0280

ORIENTAL MOTOR (MALAYSIA) SDN. BHD.  
Tel:1800-806-161

ORIENTAL MOTOR (THAILAND) CO., LTD.  
Tel:1800-888-881

ORIENTAL MOTOR (INDIA) PVT. LTD.  
Tel:1800-120-1995 (For English)  
1800-121-4149 (For Hindi)

TAIWAN ORIENTAL MOTOR CO., LTD.  
Tel:0800-060708

SHANGHAI ORIENTAL MOTOR CO., LTD.  
Tel:400-820-6516

INA ORIENTAL MOTOR CO., LTD.  
Korea  
Tel:080-777-2042

ORIENTAL MOTOR CO., LTD.  
4-8-1 Higashiueno, Taito-ku, Tokyo  
110-8536 Japan  
Tel:+81-3-6744-0361  
[www.orientalmotor.co.jp/ja](http://www.orientalmotor.co.jp/ja)