

## Motorized Linear Slide

# **EZS Series Actuator Edition**

---

## **OPERATING MANUAL**

### **Table of contents**

<b>1</b>	<b>Introduction .....</b>	<b>2</b>	<b>6</b>	<b>Connection .....</b>	<b>23</b>
<b>2</b>	<b>Safety precautions .....</b>	<b>4</b>	<b>7</b>	<b>Maintenance.....</b>	<b>28</b>
<b>3</b>	<b>Precautions for use.....</b>	<b>7</b>	<b>8</b>	<b>Standards, general</b>	
<b>4</b>	<b>Preparation .....</b>	<b>9</b>		<b>specifications.....</b>	<b>37</b>
<b>5</b>	<b>Installation.....</b>	<b>13</b>	<b>9</b>	<b>Accessories.....</b>	<b>39</b>

---

Thank you for purchasing an Oriental Motor product.

This Operating Manual describes product handling procedures and safety precautions.

- Please read it thoroughly to ensure safe operation.
- Always keep the manual where it is readily available.

# 1 Introduction

---

## 1-1 Before use

Only qualified personnel of electrical and mechanical engineering should work with the product. Use the product correctly after thoroughly reading the "2 Safety precautions" on p.4. In addition, be sure to observe the contents described in warning, caution, and note in this manual. The product described in this manual is designed and manufactured to be incorporated in general industrial equipment. Do not use for any other purpose. Oriental Motor Co., Ltd. is not responsible for any compensation for damage caused through failure to observe this warning.

## 1-2 Related operating manuals

For operating manuals, download from Oriental Motor Website Download Page or contact your nearest Oriental Motor sales office.

### ■ EZS Series equipped with the AZ Series

- **EZS** Series OPERATING MANUAL Actuator Edition (this document)
- **AZ** Series/Motorized actuator equipped with **AZ** Series OPERATING MANUAL Function Edition
- Motorized Actuator OPERATING MANUAL Function Setting Edition
- Recovery Guide

Refer to the operating manual of the driver for contents not described in these manuals.

### ■ EZS Series equipped with the AR Series

- **EZS** Series OPERATING MANUAL Actuator Edition (this document)
- **AR** Series/Motorized actuator equipped with **AR** Series USER MANUAL
- Motorized Actuator OPERATING MANUAL Function Setting Edition

## 1-3 Equipped motor list

These are the lists of the motor model that is equipped in the **EZS** Series.

The power supply current capacity of the drivers to be combined with the motorized linear slide are described in the operating manual of the driver.

Since the motor model is described in the operating manual of the driver, check by reference to those described in the tables.

### ■ EZS Series equipped with the AZ Series

#### ● AC power input type

Motorized linear slide model	Motor model
EZSM3○○○○○○AZAC	AZM46AC
EZSM3○○○○○○AZMC	AZM46MC
EZSM4○○○○○○AZAC	AZM46AC
EZSM4○○○○○○AZMC	AZM46MC
EZSM6○○○○○○AZAC	AZM66AC
EZSM6○○○○○○AZMC	AZM66MC

#### ● DC power input type

Motorized linear slide model	Motor model
EZSM3○○○○○○AZAK	AZM46AK
EZSM3○○○○○○AZMK	AZM46MK
EZSM4○○○○○○AZAK	AZM46AK
EZSM4○○○○○○AZMK	AZM46MK
EZSM6○○○○○○AZAK	AZM66AK
EZSM6○○○○○○AZMK	AZM66MK

### ■ EZS Series equipped with the AR Series

#### ● AC power input type

Motorized linear slide model	Motor model
EZSM3○○○○○○ARAC	ARM46AC
EZSM3○○○○○○ARMC	ARM46MC
EZSM4○○○○○○ARAC	ARM46AC
EZSM4○○○○○○ARMC	ARM46MC
EZSM6○○○○○○ARAC	ARM66AC
EZSM6○○○○○○ARMC	ARM66MC

#### ● DC power input type

Motorized linear slide model	Motor model
EZSM3○○○○○○ARAK	ARM46SAK
EZSM3○○○○○○ARMK	ARM46SMK
EZSM4○○○○○○ARAK	ARM46SAK
EZSM4○○○○○○ARMK	ARM46SMK
EZSM6○○○○○○ARAK	ARM66SAK
EZSM6○○○○○○ARMK	ARM66SMK

## 2 Safety precautions



The precautions described below are intended to ensure the safe and correct use of the product, and to prevent the customer and others from exposure to the risk of injury. Use the product only after carefully reading and fully understanding these instructions.

You must not operate the motorized linear slide (operate the equipment for the specified purpose) if the machine in which the motorized linear slide is installed does not satisfy the related safety standards.



The factory safety manager or safety personnel in charge of the applicable machine must ensure that the machine is operated only by qualified personnel who are familiar with the operation of electronic equipment, and thereby prevent injury or damage to the equipment.



The term “qualified personnel” refers to persons who have received the necessary training or education and have pertinent experience; who are familiar with the relevant standards, regulations, accident-prevention rules and inspection conditions; who are authorized by the factory safety manager to engage in the necessary activities; and who have the ability to discern and prevent potential dangers.

### Description of signs

 <b>WARNING</b>	Handling the product without observing the instructions that accompany a "WARNING" symbol may result in serious injury or death.
 <b>CAUTION</b>	Handling the product without observing the instructions that accompany a "CAUTION" symbol may result in bodily injury or property damage.
 <b>Note</b>	The items under this heading contain important handling instructions that the user should observe to ensure the safe use of the product.

### Description of graphic symbols





	Indicates "prohibited" actions that must not be performed.
	Indicates "compulsory" actions that must be performed.

 <b>WARNING</b>	
	<ul style="list-style-type: none"> <li>• Do not use the product in explosive or corrosive environments, in the presence of flammable gases, in places subjected to splashing water, or near combustibles. Doing so may result in fire, electric shock, or injury.</li> <li>• Do not transport, install, connect, or inspect the motorized linear slide while the power is supplied. Doing so may result in electric shock.</li> <li>• Do not forcibly bend, pull, or pinch the cable. Doing so may result in fire or electric shock.</li> <li>• Do not disassemble or modify the motorized linear slide. Doing so may result in injury or damage to equipment.</li> <li>• Never use a motorized linear slide in a medical device used in connection with the maintenance or management of human life or health, or in a transportation system whose purpose is to move or carry people.</li> <li>• Do not use the electromagnetic brake for braking or as a safety brake. Doing so may result in injury or damage to equipment.</li> <li>• Do not collide the table with the mechanical stopper in operations other than push-motion return-to-home operation or push-motion operation. Doing so may result in injury or damage to equipment.</li> </ul>

## ⚠️ WARNING



- Assign qualified personnel to the task of installing, wiring, operating/controlling, inspecting and troubleshooting the motorized linear slide. Handling by unqualified personnel may result in fire, electric shock, injury, or damage to equipment.
- Take measures to keep the moving part in position if the product is used in vertical operations such as elevating equipment. Failure to do so may result in injury or damage to equipment.
- Operate the data setter outside the safety cage. Failure to do so may result in injury.
- Be sure to provide a safety cage conforming to EN ISO 13857 to prevent persons from entering the moving range of the motorized linear slide while power is supplied to the motorized linear slide. Turn off the main power to the driver before performing adjustment or inspection in which the table is moved manually. Accidental contact may result in serious injury.
- When an alarm is generated in the driver (any of the driver's protective functions is triggered), take measures to hold the moving part in a specific position since the motorized linear slide stops and loses its holding torque. Failure to do so may result in injury or damage to equipment.
- Install the motorized linear slide inside an enclosure. Failure to do so may result in electric shock or injury.
- Be sure to ground the AC input type motorized linear slide as it is Class I equipment. Failure to do so may result in electric shock.
- Provide an emergency stop device or emergency stop circuit external to the equipment so that the entire equipment will operate safely in the event of a system failure or malfunction. Failure to do so may result in injury.
- Perform the return-to-home operation after the power is restored. When the absolute-position backup system is used, positioning operation of the absolute mode is executed. Failure to do so may result in injury or damage to equipment.
- Operate the motorized linear slide after setting the resolution, moving direction or other parameters. If the motorized linear slide is operated without setting parameters, the table may move to unexpected directions or run at unexpected speeds, causing injury or damage to equipment. (A variety of parameters have been set to the motorized linear slide equipped with the **AZ** Series at the time of shipment.)
- For the motorized linear slides equipped with the **AZ** Series, be sure to create the recovery data file according to the **AZ** Series [OPERATING MANUAL Function Edition](#) or the [Recovery Guide](#) before starting up the equipment. Failure to do so may cause the table to move to an unexpected direction or at an unexpected speed, resulting in injury or damage to equipment.
- After replacing the driver, set the resolution, moving direction or other parameters before operating the motorized linear slide. If the motorized linear slide is operated without setting parameters, the table may move to unexpected directions or run at unexpected speeds, causing injury or damage to equipment.
- Be sure to secure the motorized linear slide according to the screw size and tightening torque which are specified in this manual. Failure to do so may result in injury or damage to equipment.

 <b>CAUTION</b>	
	<ul style="list-style-type: none"> <li>• Do not use the motorized linear slide beyond its specifications. Doing so may result in electric shock, injury or damage to equipment.</li> <li>• Keep your fingers and objects out of the openings in the motorized linear slide. Failure to do so may result in fire, electric shock or injury.</li> <li>• Do not touch the motorized linear slide while operating or immediately after stopping. Doing so may result in a skin burn(s).</li> <li>• Do not carry the motorized linear slide by holding its cables or its moving part. Doing so may cause injury.</li> <li>• Keep the area around the motorized linear slide free of combustible materials. Failure to do so may result in fire or a skin burn(s).</li> <li>• Do not leave anything around the motorized linear slide that would obstruct ventilation. Doing so may result in damage to equipment.</li> <li>• Do not touch the moving part during operation. Doing so may result in injury.</li> <li>• Do not touch the terminals while conducting the insulation resistance measurement or the dielectric strength test. Accidental contact may result in electric shock.</li> <li>• Do not use our sensor set as safety components. Doing so may result in injury or damage to equipment.</li> </ul>
	<ul style="list-style-type: none"> <li>• Use a motorized linear slide and driver only in the specified combination. An incorrect combination may cause a fire.</li> <li>• The motorized linear slide is very heavy. When transporting or installing the motorized linear slide, make sure two persons work together to carry out the necessary tasks. Failure to do so may result in injury.</li> <li>• Wear a helmet, safety shoes, gloves or other protective gear when transporting or installing the motorized linear slide. Failure to do so may result in injury.</li> <li>• When replacing a motor, use the motor whose model name is the same as the one mounted at the time of shipment. If a motor being different from the one at the time of shipment is mounted, the specifications cannot be satisfied, and, in addition, damage to equipment or injury may result.</li> <li>• The motor surface temperature may exceed 70 °C (158 °F) even under normal operating conditions. If the operator is allowed to approach the motorized linear slide in operation, affix a warning label shown in the figure on a conspicuous position. Failure to do so may result in a skin burn(s)</li> </ul> <div style="text-align: right; margin-top: 10px;">               Warning label         </div>

## 3 Precautions for use

This chapter covers restrictions and requirements the user should consider when using the product.

### ■ General

#### ● Be sure to use our cable to connect the motorized linear slide and the driver.

In the following cases, purchase our cable separately. Check on the Oriental Motor Website for the model name of cables.

- If a flexible cable is to be used.
- If a cable of 3 m (9.8 ft.) or longer is to be used.
- If a motorized linear slide and driver package without a cable was purchased.
- If an actuator only was purchased.

#### ● When conducting the insulation resistance measurement or the dielectric strength test, be sure to separate the connection between the motorized linear slide and the driver.

Conducting the insulation resistance measurement or dielectric strength test with the motorized linear slide and driver connected may result in damage to the product.

#### ● Do not make an impact on the motorized linear slide.

Do not drop the motorized linear slide. Also, do not hit the motorized linear slide on something hard. Doing so may cause the positioning accuracy decrease, the motorized linear slide damage or the product service life reduction.

#### ● Make sure not to hit or apply a strong impact on the encoder (ABZO sensor).

- The warning label shown in the right is indicated on the motor of the motorized linear slide equipped with the **AZ** Series.
- Making a strong impact on an encoder (ABZO sensor) may cause the motorized linear slide malfunction or damage to the encoder (ABZO sensor). When transporting the motorized linear slide or installing a load, handle the motorized linear slide carefully not to make a strong impact on the moving part.

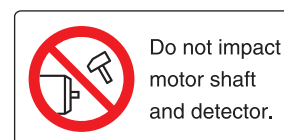

Warning label

#### ● Do not move the encoder (ABZO sensor) toward a strong magnetic field.

A magnetic sensor is built into the encoder (ABZO sensor). If the motorized linear slide is installed close to equipment which generates a strong magnetic field, the encoder (ABZO sensor) may break or malfunction. Keep the magnetic flux density on the surface of the encoder (ABZO sensor) so as not to exceed the values in the table.

	Magnetic flux density
When operating	10 mT
When transporting and storing	10 mT

#### ● Meshing noise of mechanical sensor

A gear type mechanical sensor is built into the encoder (ABZO sensor). Although the meshing noise of gears may generate, it is not malfunction.

### ■ Temperature

#### ● Use the motorized linear slide equipped with the **AZ** Series in conditions where the motor surface temperature does not exceed 80 °C (176 °F).

The motor surface temperature may exceed 80 °C (176 °F) under certain conditions (ambient temperature, operating speed, duty cycle, etc.). In order to protect the encoder (ABZO sensor), use the motor in conditions where the surface temperature does not exceed 80 °C (176 °F). If the encoder (ABZO sensor) temperature reaches the upper limit, the motor overheat alarm will generate.

#### ● Use the motorized linear slide equipped with the **AR** Series in conditions where the motor surface temperature does not exceed 100 °C (212 °F).

The motorized linear slide does not have a function to protect from overheating. The motor surface temperature may exceed 100 °C (212 °F) under certain conditions (ambient temperature, operating speed, duty cycle, etc.). To prevent the motor bearings (ball bearings) from reaching its usable life quickly, use the motor in conditions where the surface temperature does not exceed 100 °C (212 °F).

## ■ Operation

- In the case of the DC power input type products, the maximum speed may not be reached depending on the ambient temperature or the length of the motor cable.

- **Holding torque at standstill**

When the motorized linear slide stops, the holding torque will be reduced by the current cutback function of the driver. When selecting the motorized linear slide, check the holding torque at standstill in the specifications on the catalog.

- **Do not use the electromagnetic brake for braking or as a safety brake.**

Do not use the electromagnetic brake as means to decelerate and stop the motorized linear slide. The brake hub of the electromagnetic brake will wear significantly and the braking force will drop. Since the power off activated type electromagnetic brake is equipped, it helps maintain the position of the load when the power is cut off, but this brake cannot securely hold the load in place. Accordingly, do not use the electromagnetic brake as a safety brake. To use the electromagnetic brake to hold the load in place, do so after the motorized linear slide has stopped.

## ■ Notes when the connection cable is used

Note the following points when our cable is used.

- **When inserting the connector**

Hold the connector main body, and insert it in straight securely. Inserting the connector in an inclined state may result in damage to terminals or a connection failure.

- **When pulling out the connector**

Pull out the connector in straight while releasing the lock part of the connector. Pulling out the connector with holding the cable (lead wire) may result in damage to the connector.

- **Bending radius of cable**

Use the cable in a state where the bending radius of the cable is more than six times of the cable diameter.

Do not bend the lead wires part or fix it with a clamp. Doing so may cause damage to the connector.

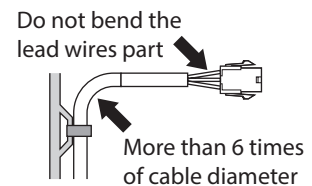

- **How to fix the cable**

Fix the cable near the connectors at two places as shown in the figure or fix it with a wide clamp to take measures to prevent stress from being applied to the connectors.

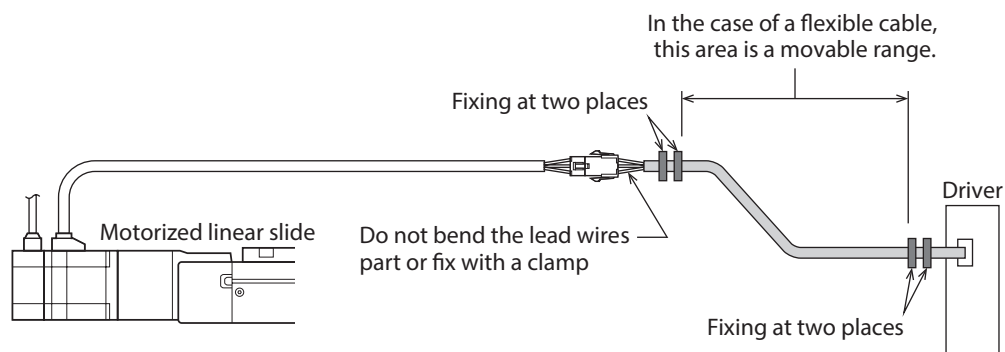

# 4 Preparation

This chapter explains the items you should check, as well as the name of each part.

## 4-1 Checking the product

Verify that the items listed below are included. Report any missing or damaged items to the Oriental Motor sales office from which you purchased the product.

When purchasing a motorized linear slide and driver package	When purchasing a motorized linear slide only
<ul style="list-style-type: none"> <li>• Motorized linear slide</li> <li>• Driver</li> <li>• Instructions and Precautions for Safe Use</li> <li>• Recovery Guide (Included with the models equipped with the <b>AZ</b> Series)</li> <li>• APPENDIX UL Standards *1</li> <li>• Bolts for mounting the motorized linear slide (4 pcs.)</li> <li>• Connectors bag</li> <li>• Cable for motor *2</li> <li>• Cable for electromagnetic brake *2 (Included with electromagnetic brake types)</li> <li>• Cable for encoder *2 (Included with the models equipped with the <b>AZ</b> Series)</li> <li>• Varistor *3 (Included with the models equipped with the <b>AR</b> Series)</li> </ul>	<ul style="list-style-type: none"> <li>• Motorized linear slide</li> <li>• Instructions and Precautions for Safe Use</li> <li>• Recovery Guide (Included with the models equipped with the <b>AZ</b> Series)</li> <li>• APPENDIX UL Standards *1</li> <li>• Bolts for mounting the motorized linear slide (4 pcs.)</li> <li>• Varistor *4 (Included with the models equipped with the <b>AR</b> Series)</li> </ul>

\*1 Included with products conform to the UL Standards.

\*2 When the product is included with a connection cable.

\*3 Included with the motorized linear slides equipped with the DC power input type motor with electromagnetic brake which are combined with the pulse input type driver.

\*4 Included with the motorized linear slides equipped with the DC power input type motor with electromagnetic brake.

## 4-2 How to identify the product model

Verify the model name of the purchased product against the number shown on the package label.  
Check the model name of the motorized linear slide against the number shown on the nameplate.

### ■ Motorized linear slide and driver package model

EZS 4 R - E 050 - AZ M K D -1  
1 2 3 5 6 7 8 9 10 11

#### Models for clean room use

EZS 4 CL - E 050 - AZ M K D -1  
1 2 4 5 6 7 8 9 10 11

1	Series name	<b>EZS</b> : <b>EZS</b> Series
2	Linear slide size	<b>3</b> : Width 54 mm, Height 50 mm <b>4</b> : Width 74 mm, Height 50 mm <b>6</b> : Width 74 mm, Height 66.5 mm
3	Motor mounting direction	<b>R</b> : Parallel motor mounting type (Right side) <b>L</b> : Parallel motor mounting type (Left side) Blank : In-line motor mounting type
4	Direction of air coupler for suction	<b>CR</b> : Right <b>CL</b> : Left
5	Ball screw lead	<b>D</b> : 12 mm <b>E</b> : 6 mm
6	Stroke	<b>005</b> to <b>085</b> : 50 to 850 mm (50 mm unit)
7	Motor	<b>AZ</b> : <b>AZ</b> Series <b>AR</b> : <b>AR</b> Series
8	Motor type	<b>A</b> : Single shaft <b>M</b> : With electromagnetic brake
9	Power supply input	<ul style="list-style-type: none"> <li>Motorized linear slide equipped with the <b>AZ</b> Series               <ul style="list-style-type: none"> <li><b>A</b> : Single-phase 100-120 VAC</li> <li><b>C</b> : Single-phase/Three-phase 200-240 VAC</li> <li><b>K</b> : 24/48 VDC</li> </ul> </li> <li>Motorized linear slide equipped with the <b>AR</b> Series               <ul style="list-style-type: none"> <li><b>A</b> : Single-phase 100-120 VAC (Single-phase 100-115 VAC for the pulse input type)</li> <li><b>C</b> : Single-phase 200-240 VAC (Single-phase 200-230 VAC for the pulse input type)</li> <li><b>S</b> : Three-phase 200-230 VAC (For the pulse input type only)</li> <li><b>K</b> : 24/48 VDC</li> </ul> </li> </ul>
10	Driver type	<b>D</b> : Built-in controller type Blank: Pulse input type
11	Connection cable	Number : Length of included connection cable (m) Blank : Without connection cable

## ■ Motorized linear slide model

EZSM 4 R E 050 AZ M K  
 1 2 3 5 6 7 8 9

### Models for clean room use

EZSM 4 CL E 050 AZ M K  
 1 2 4 5 6 7 8 9

1	Series name	<b>EZSM : EZS Series</b>
2	Linear slide size	<b>3</b> : Width 54 mm, Height 50 mm <b>4</b> : Width 74 mm, Height 50 mm <b>6</b> : Width 74 mm, Height 66.5 mm
3	Motor mounting direction	<b>R</b> : Parallel motor mounting type (Right side) <b>L</b> : Parallel motor mounting type (Left side) Blank : In-line motor mounting type
4	Direction of air coupler for suction	<b>CR</b> : Right <b>CL</b> : Left
5	Ball screw lead	<b>D</b> : 12 mm <b>E</b> : 6 mm
6	Stroke	<b>005</b> to <b>085</b> : 50 to 850 mm (50 mm unit)
7	Motor	<b>AZ</b> : <b>AZ</b> Series <b>AR</b> : <b>AR</b> Series
8	Motor type	<b>A</b> : Single shaft <b>M</b> : With electromagnetic brake
9	Motor power supply type	<b>C</b> : AC power supply input <b>K</b> : DC power supply input

## 4-3 Names of parts

- In-line motor mounting type

- Parallel motor mounting type

- Models for clean room use

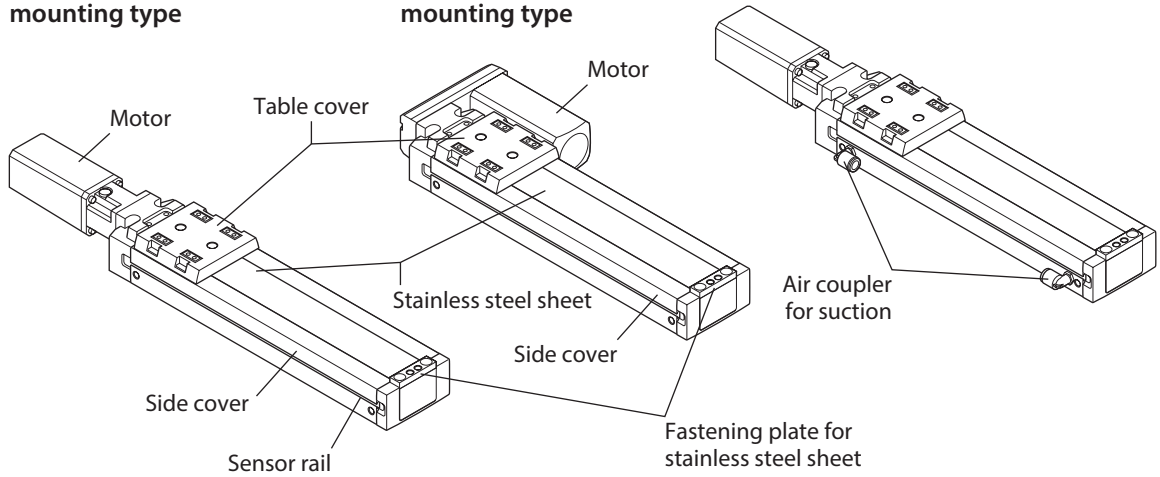

\* Only the in-line motor mounting type is available for the models for clean room use.

### ■ Mechanism of the parallel motor mounting type

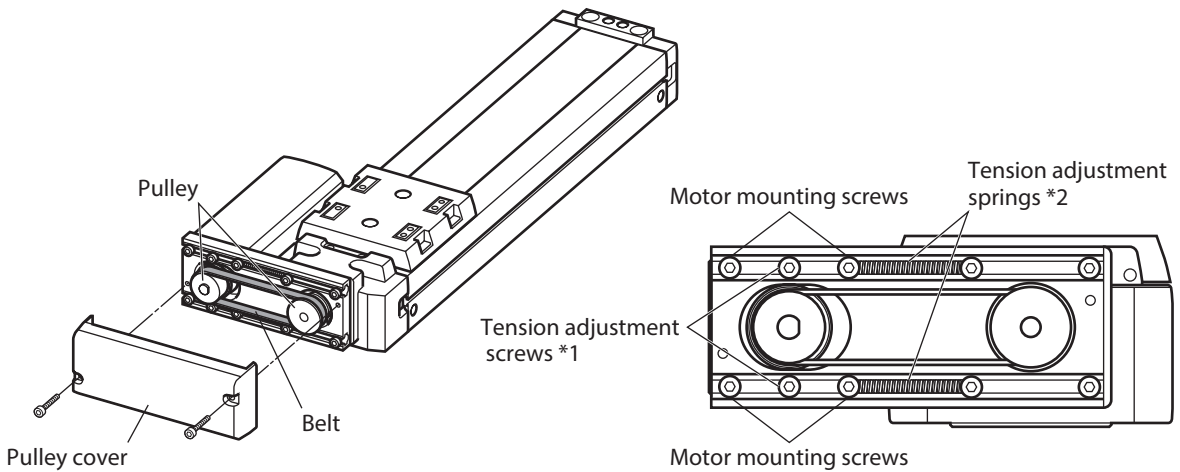

\*1 The motor is fixed in the position where the belt tension becomes optimum.

\*2 Springs for belt tension adjustment are installed.

### ■ Motor

The following figures show models for the electromagnetic brake type and AC power input.

- Motorized linear slide equipped with the AZ Series

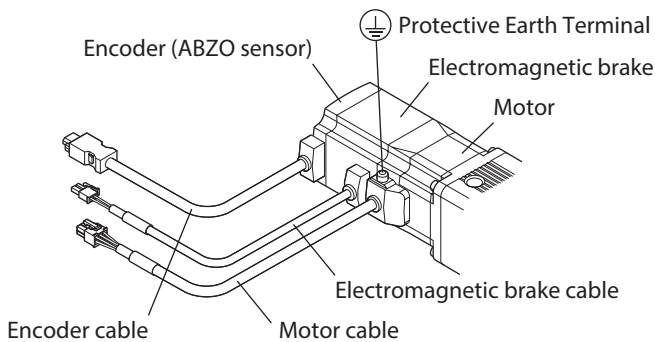

- Motorized linear slide equipped with the AR Series

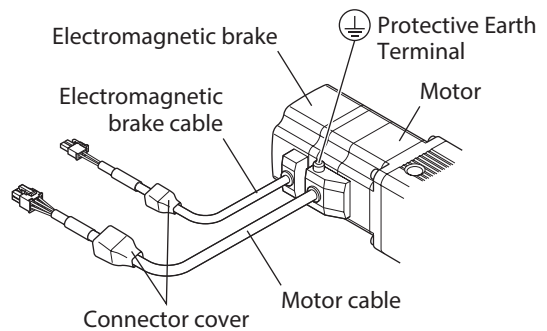

# 5 Installation

## 5-1 Location for installation

The motorized linear slide is designed and manufactured to be incorporated in equipment. Install it in a well-ventilated location that provides easy access for inspection. The location must also satisfy the following conditions:

- Inside an enclosure that is installed indoors (provide vent holes)
- Operating ambient temperature: 0 to +40 °C [+32 to 104 °F] (non-freezing)
- Operating ambient humidity: 85 % or less (non-condensing)
- Area free of explosive atmosphere, or toxic gas (such as sulfuric gas), or liquid
- Area not exposed to direct sun
- Area free of excessive amount of dust, iron particles or the like
- Area not subject to splashing water (rain, water droplets), oil (oil droplets) or other liquids
- Area free of excessive salt
- Area not subject to continuous vibrations or excessive shocks
- Area free of excessive electromagnetic noise (from welders, power machinery, etc.)
- Area free of radioactive materials, magnetic fields or vacuum
- Up to 1000 m (3300 ft.) above sea level

### ■ If a motorized linear slide is installed in an environment where a magnetic field is generated

A magnetic sensor is built into the encoder (ABZO sensor). If the motorized linear slide is installed close to equipment which generates a strong magnetic field, the encoder (ABZO sensor) may break or malfunction. Make sure to prevent the magnetic flux density on the surface of the encoder (ABZO sensor) from exceeding 10 mT.



Do not install the motorized linear slide close to equipment which generates a strong magnetic field.

## 5-2 Installing the motorized linear slide

The **EZS** Series is available for horizontal installation, vertical installation, and wall-mount installation. Taking account of vibration prevention as well as deflection of the motorized linear slide, install it on a metal surface of sufficient strength (thickness 10 mm or more). Secure so that the entire area of the bottom face of the motorized linear slide contacts the mounting plate.

### ■ Installation procedure

- 1 Use the positioning pin holes and the positioning pins to position the motorized linear slide. (⇒ p.16)  
Use the guide rail reference surfaces and the mounting reference surfaces of the motorized linear slide to position.
- 2 Secure the motorized linear slide from the upper side with the included bolts for mounting. (⇒ p.17)
- 3 Secure the motorized linear slide from the back side of the mounting plate with screws (not included). (⇒ p.17)

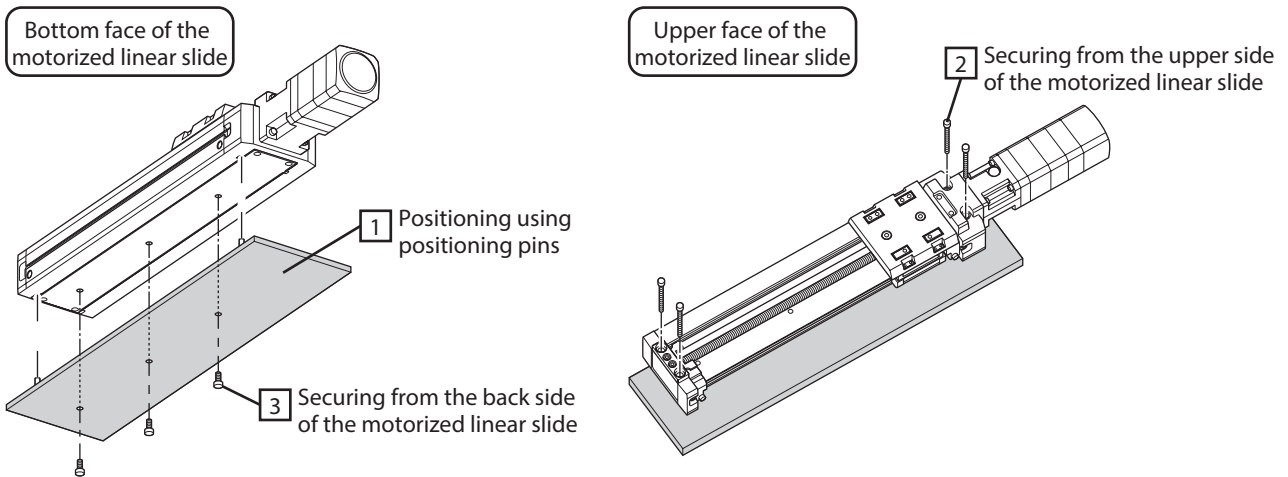

■ **Mounting plate**

The thickness of the mounting plate described in the table is the minimum requirements for installation. If the accuracy is required, design the thickness of the mounting plate in consideration of the installation conditions such as load condition, rigidity, vibration and others.

Model	Material	Thickness	Flatness against the mounting reference surface
<b>EZSM3</b>	Aluminum	10 mm or more	0.05 mm or less
<b>EZSM4, EZSM6</b>			0.06 mm or less

■ **Mounting screw, positioning pin**

Model	Bolt for mounting (Included with the product.)	Guide rail fixing screw	Positioning pin
<b>EZSM3, EZSM4</b>	M5×45 mm Length from the bottom face of the motorized linear slide : 8 mm	M5 Length from the mounting plate : 6 mm or less	ø3 mm Length from the mounting plate : 4 mm or less
<b>EZSM6</b>	M5×65 mm Length from the bottom face of the motorized linear slide : 12 mm		

**Note** About the length of mounting screws and positioning pins, be sure to observe the specified value. Exceeding the specified value may cause the motorized linear slide to break, leading to injury or mechanical damage.

■ **Release the electromagnetic brake**

When moving the table of the motorized linear slide with an electromagnetic brake for adjusting the position or others, connect the 24 VDC power supply for electromagnetic brake to release the electromagnetic brake.

**memo** If a cable for mini Driver is used, the electromagnetic brake cannot be released using a DC power supply. Refer to the operating manual of the mini Driver on how to release the electromagnetic brake.

● Specifications of a power supply for electromagnetic brake

Model	Voltage	Current capacity
<b>EZSM3, EZSM4</b>	24 VDC±5 % *	0.08 A or more
<b>EZSM6</b>		0.25 A or more

\* If the distance between the motorized linear slide with an electromagnetic brake and the driver is extended to the following length, use a power supply of 24 VDC±4 %.

Motorized linear slide equipped with the **AZ** Series : 20 m (65.6 ft.)

Motorized linear slide equipped with the **AR** Series : 20 to 30 m (65.6 to 98.4 ft.)

● Releasing procedure

1. Connect the “electromagnetic brake cable” and “cable for electromagnetic brake.”
2. Connect the lead wires of the “cable for electromagnetic brake” to the 24 VDC power supply.  
Connect the white lead wire to the +24 VDC terminal, and the black lead wire to the GND terminal.
3. Turn on the 24 VDC power supply.  
The electromagnetic brake will be released and the table will be able to move by hand.

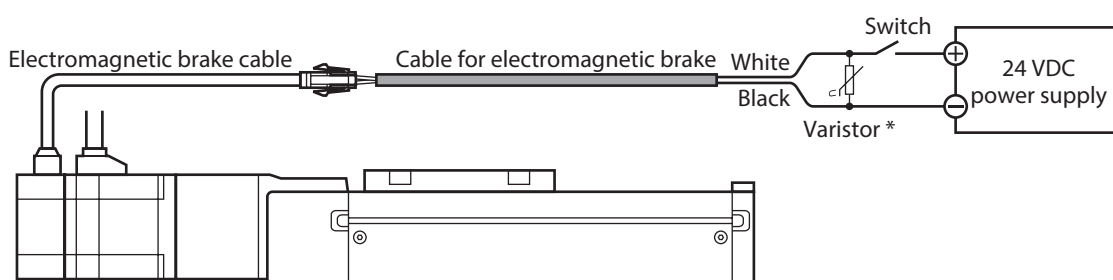

\* Be sure to connect the varistor to protect the contact of the switch or to prevent electrical noise.

Motorized linear slide equipped with the **AZ** Series : Recommended varistor: Z15D121 (SEMITEC Corporation)

Motorized linear slide equipped with the **AR** Series : Use the included varistor.

**Note** Connect the lead wires of the electromagnetic brake in the correct polarities since they have polarities. Connecting the lead wires in wrong polarities will not properly operate the electromagnetic brake.

■ Positioning the motorized linear slide

There are two types of reference surfaces for the positioning pin holes. One is the reference surface used the side of the guide rail, and the other is the mounting reference surface of the motorized linear slide. Use the guide rail reference surfaces in the Y direction and the mounting reference surfaces in the X direction to position the motorized linear slide.

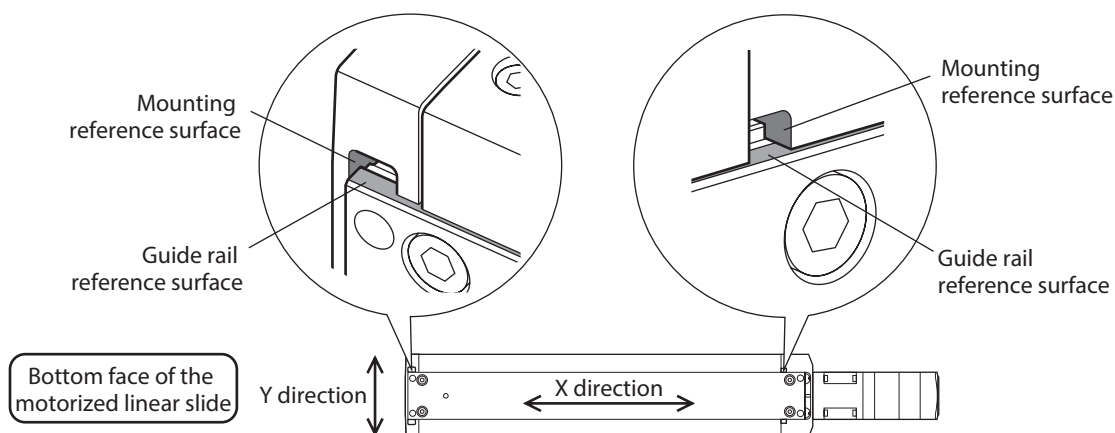

Provide positioning pins (2 pieces) on the mounting plate first, and position the motorized linear slide. Use the positioning pins of diameter  $\varnothing 3$  mm, and keep the height from the mounting plate to be 4 mm or less.

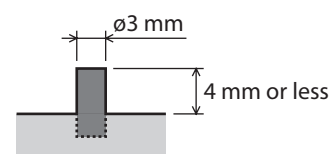

● Working procedure

1. Use the guide rail reference surfaces to position the Y direction.  
Position while pressing the guide rail reference surfaces to positioning pins.

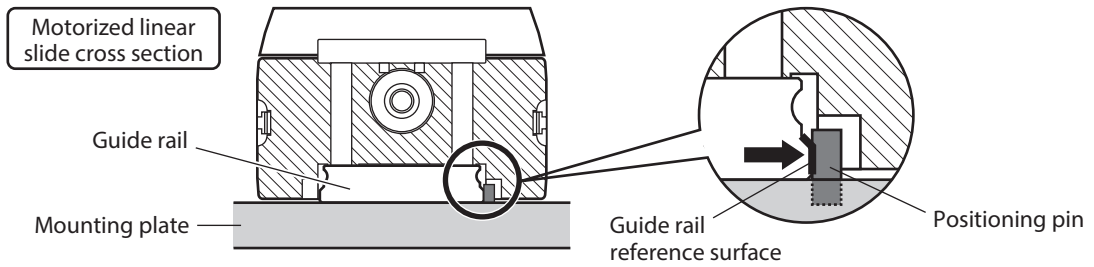

2. Use the mounting reference surface to position the X direction.  
There are two types of mounting reference surfaces, A and B. Position the mounting reference surface A or B by pressing to either of the positioning pins which have been positioned in the procedure 1.

**EZSM3** Example) When pressing the mounting reference surface A to the positioning pin

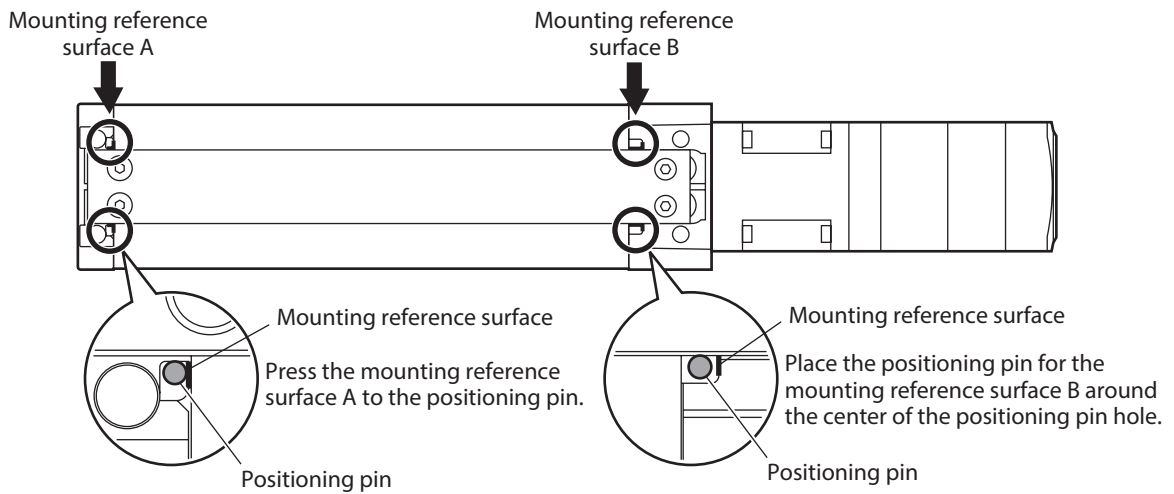

**EZSM4, EZSM6** Example) When pressing the mounting reference surface B to the positioning pin

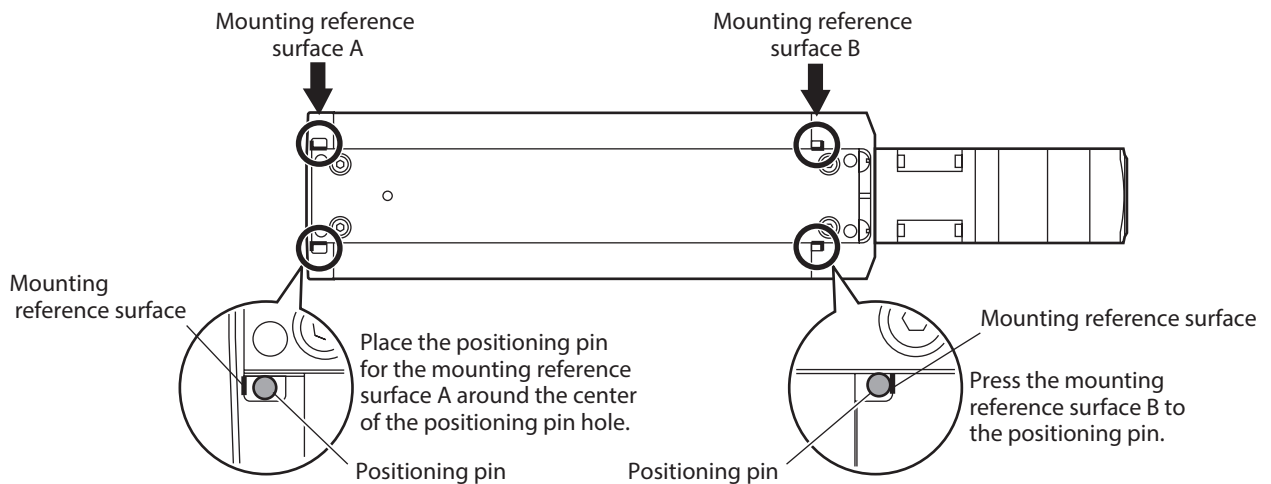

## ■ How to install the motorized linear slide

Install so that the entire area of the bottom face of the motorized linear slide contacts the mounting plate.

1. Secure the motorized linear slide from the upper face using the included bolts for mounting.
2. Secure the guide rail from the back side of the mounting plate with screws (not included).

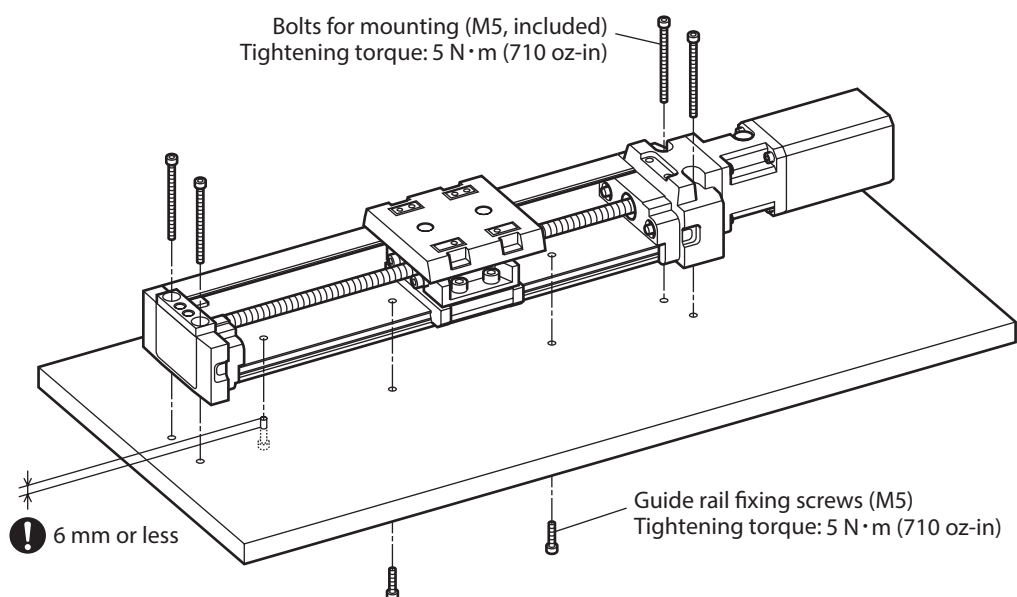

### **⚠ WARNING**

- Be sure to secure the motorized linear slide according to the screw size and tightening torque which are specified in this manual. Failure to do so may result in injury or damage to equipment.
- The thickness of the guide rail is 6 mm. Make sure the screw length to secure the guide rail is 6 mm or less from the mounting plate. Exceeding 6 mm may cause the table to break, leading to injury or mechanical damage.

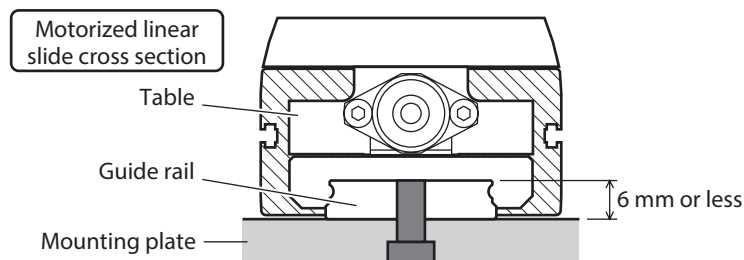

## 5-3 Changing the motor cable outlet direction

The motor cable outlet direction can be changed according to the space of equipment.

### **⚠ WARNING**

- When changing the motor cable outlet direction, remove the load, and perform in a state where the motorized linear slide is placed in a horizontal position. Doing the operation in a vertical condition may allow the moving part to fall, leading to injury or mechanical damage.
- If the motor mounting screws are removed in a state where the motorized linear slide is installed vertically, the motor may rotate rapidly. Thereby, fingers may be caught in the product or the cable may be disconnected.
- Set the home again after mounting a motor. If the motorized linear slide is operated without setting the home, the moving part may move to unexpected directions or run at unexpected speeds, leading to injury or mechanical damage.
- The moving part of the motorized linear slide may collide with the mechanical stopper.
- The load may collide with other equipment.
- Be sure to secure the coupling with the specified tightening torque. Unless it is secured with the specified torque, the ball screw may rotate idly, leading to injury or mechanical damage.
- When the motorized linear slide is used in a vertical condition, the load may fall.
- When the motorized linear slide is used in a horizontal condition, the moving part of the motorized linear slide may collide with the mechanical stopper. Also, the load may collide with other equipment.

### ■ In-line motor mounting type

1. Remove the cap, and loosen the coupling fixing screw.

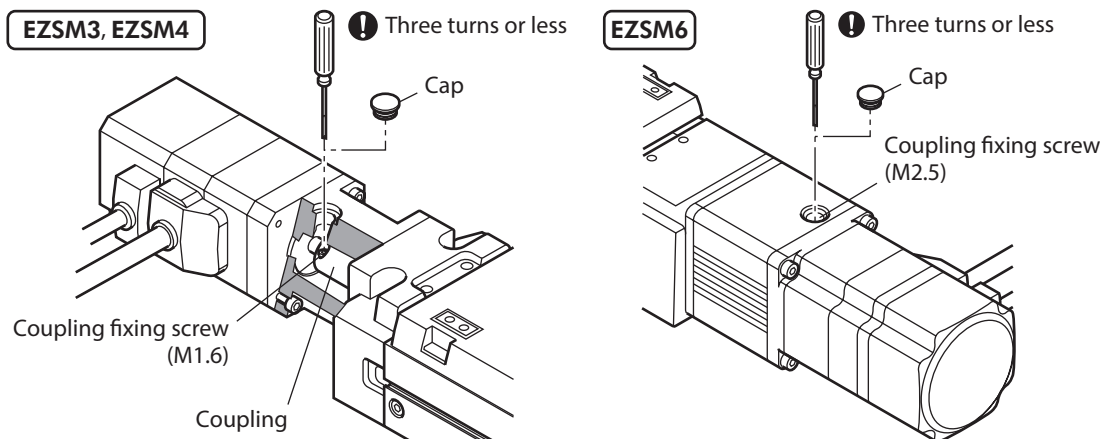

- When loosening the coupling fixing screw, do not insert the tool diagonally.
- Do not use the ball-end hex key.
- To prevent the coupling fixing screw from falling off, keep three turns or less when turning the screw.

2. Remove the motor mounting screws, and dismount the motor.

**EZSM3, EZSM4**

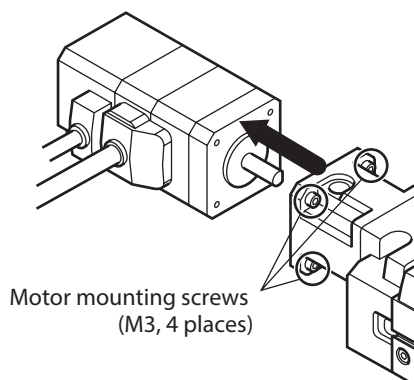

**EZSM6**

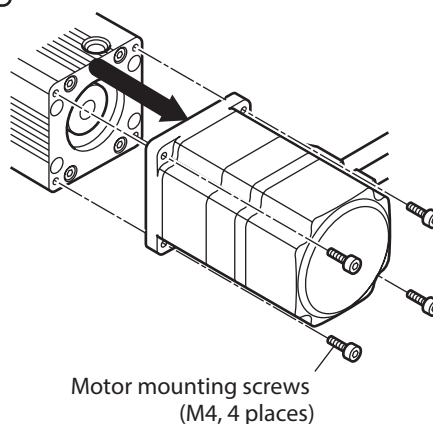

**Note** Be sure to remove the motor when changing the motor cable outlet direction. If the motor is rotated for direction change while the mounting surface of the motor and actuator are in contact, the motor may not be removed.

3. Change the cable outlet direction, and mount the motor.  
Mount the motor according to the procedure opposite of dismantling it.  
Refer to the table below for the tightening torque of the coupling fixing screw and motor mounting screw.

Model	Coupling fixing screw		Motor mounting screw	
	Screw size	Tightening torque	Screw size	Tightening torque
<b>EZSM3, EZSM4</b>	M1.6	0.25 N·m (35 oz-in)	M3	1 N·m (142 oz-in)
<b>EZSM6</b>	M2.5	1 N·m (142 oz-in)	M4	2.4 N·m (340 oz-in)

**memo** Use a tool capable of controlling the torque when tightening the coupling fixing screw.

4. After mounting the motor, set the home again.

### ■ Parallel motor mounting type

The cable outlet direction can be changed to one of three directions.

1. Remove the pulley cover fixing screws, and detach the pulley cover.

**EZSM3, EZSM4**

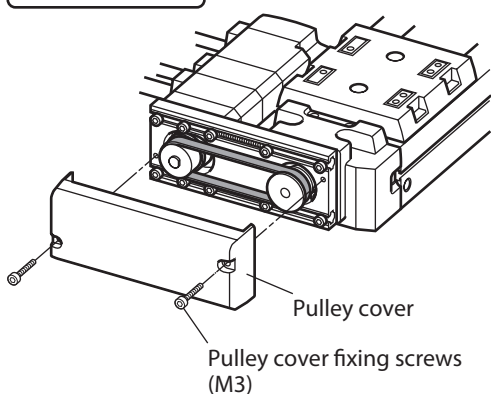

**EZSM6**

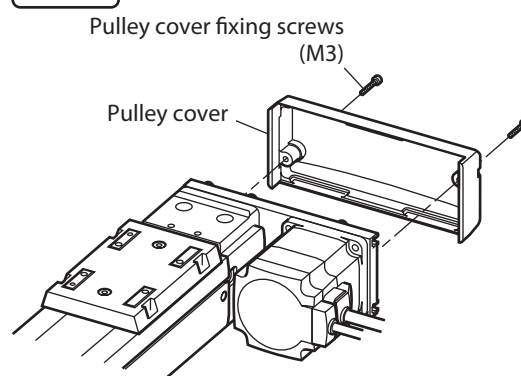

2. Remove the motor mounting screws, and dismount the motor.

**EZSM3, EZSM4**

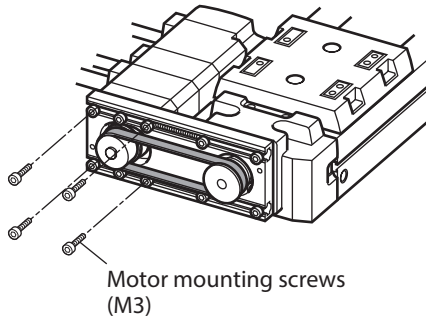

**EZSM6**

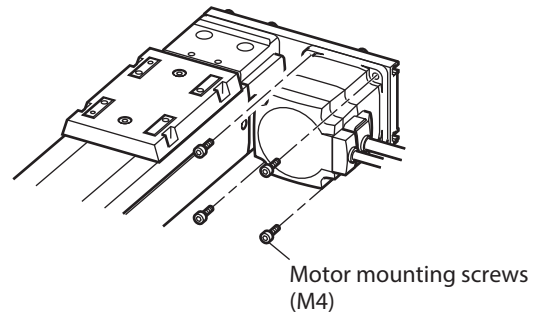

**Note**

- Be sure to remove the motor when changing the motor cable outlet direction. If the motor is rotated for direction change while the mounting surface of the motor and actuator are in contact, the motor may not be removed.
- Do not loosen or remove the screws other than the motor mounting screws.

**EZSM3, EZSM4**

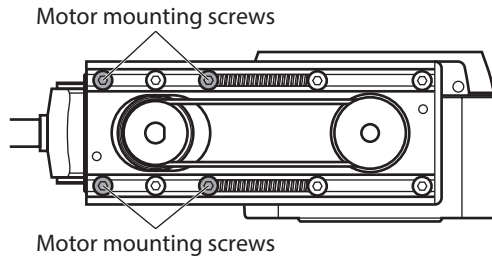

**EZSM6**

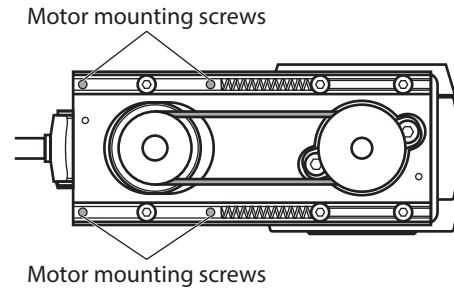

3. Change the cable outlet direction, and mount the motor to tentatively fix the motor mounting screws. Tentatively fix the screws in a degree to be able to move the motor when touching it.

**EZSM3, EZSM4**

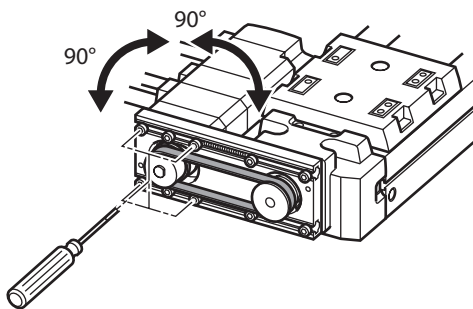

**EZSM6**

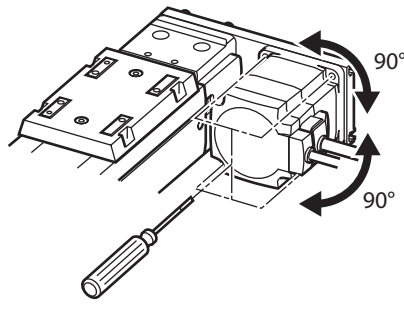

4. Loosen the tension adjustment screws. When loosening the screws, tension of the belt will be adjusted properly by the strength of springs.

**EZSM3, EZSM4**

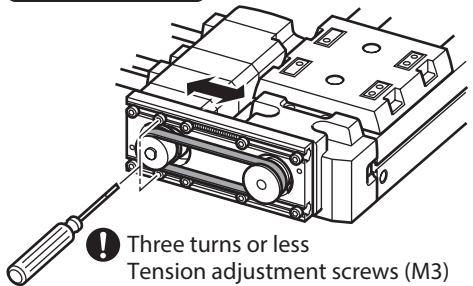

**EZSM6**

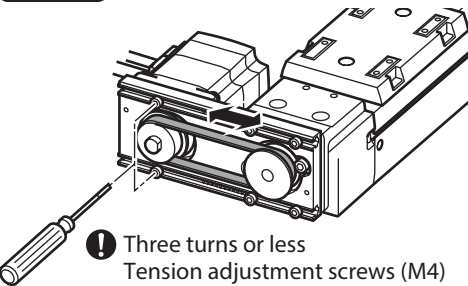

**memo** To prevent the tension adjusting screws from falling off, keep three turns or less when turning the screw.

5. Tighten the motor mounting screws with pressing the motor in the direction of arrow so that the motor does not tilt.

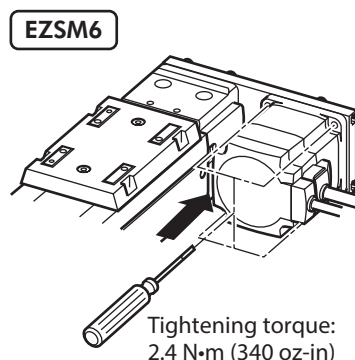
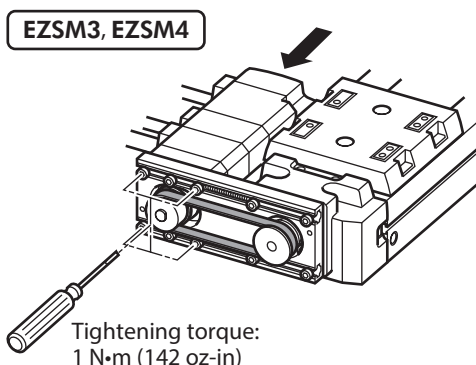

6. Tighten the tension adjustment screws.

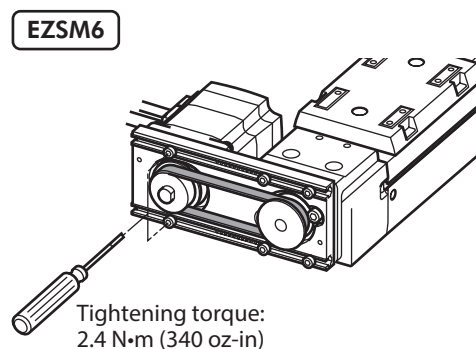
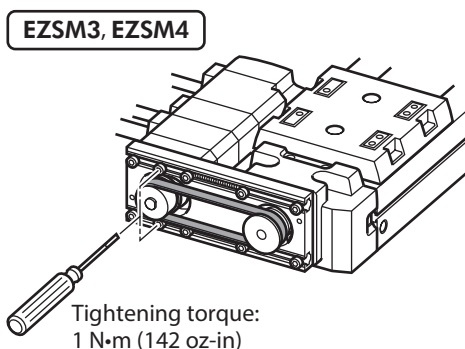

7. Attach the pulley cover, and tighten the screws.  
Tightening torque: 1 N·m (142 oz-in)

8. After mounting the motor, set the home again.

## 5-4 How to install a load

Using the load-installation screw holes on the table, install a load with screws.  
Values of the tightening torque are recommended.  
Tighten with an appropriate torque according to the design conditions of the load.

### **⚠ WARNING**

For the load fixing screws, be sure not to screw deeper than the length of 8 mm in the table. Exceeding 8 mm may cause the table to break, leading to injury or mechanical damage.

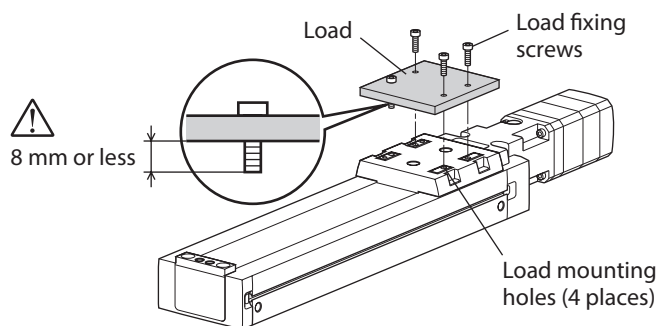

Model	Screw size	Tightening torque
<b>EZSM3</b> <b>EZSM4</b>	M4	2.4 N·m (340 oz-in)
<b>EZSM6</b>	M5	5 N·m (710 oz-in)

### ■ Load-positioning pin holes of table

Two types of load-positioning pin holes, which are an elongated hole and a round hole, are provided one place each on the table.

If installation repeatability is required when installing a load, use the load-positioning pin holes.

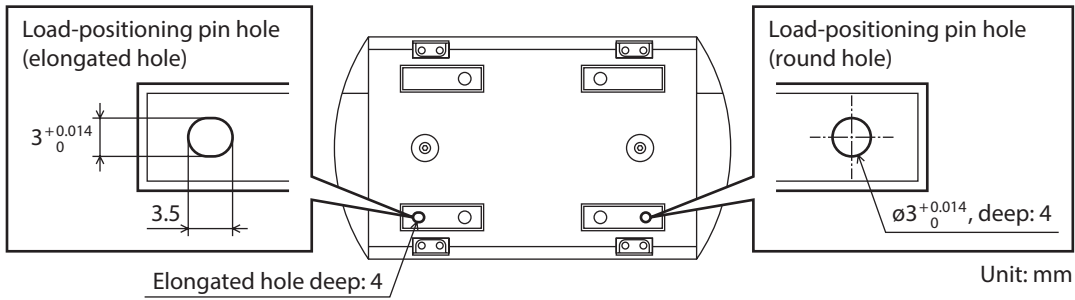

**Note** Be sure to secure positioning pins to a load side. Securing the positioning pins to the table may damage the motorized linear slide due to impact or an excessive moment of inertia.

When installing a load being required the perpendicularity against the moving direction of the table, adjust the perpendicularity of the load using the round load-positioning pin hole.

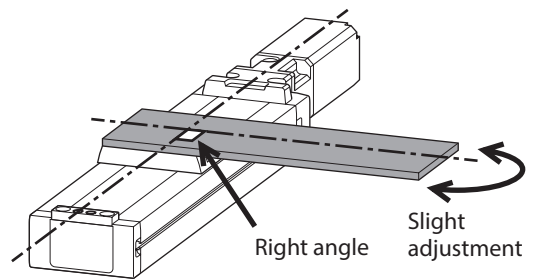

# 6 Connection

## 6-1 Connecting the driver

For details about the connection method of the driver, refer to the operating manual of the driver.

## 6-2 Grounding

- memo**
- When multiple actuators of AC power input type are used in combination, provide protective earth for each actuator.
  - Do not share the grounding wire with a welder or power equipment.

### ■ AZ Series

Protective earth is not required for DC power input type actuators. Ground the functional earth terminal (M4) if necessary.

AC power input type actuators can be grounded by connecting the protective earth wire of the cable for motor to the Protective Earth Terminal of the driver. However, if grounding the protective earth wire of the cable for motor does not satisfy the grounding resistance required by the applicable standard of the equipment, the Protective Earth Terminal of the motor must also be grounded.

#### 1) Grounding the protective earth wire of the motor

Connect the protective earth wire of the cable for motor to the Protective Earth Terminal of the driver.

Equipped motor	AZ Series	
Cable type	Connection cable	Flexible connection cable
Conductor size	AWG18 (0.75 mm <sup>2</sup> )	AWG18 (0.75 mm <sup>2</sup> )
Maximum conductor resistance	21.8 Ω/km	25.6 Ω/km
Tightening torque	1.2 N·m (170 oz-in)	

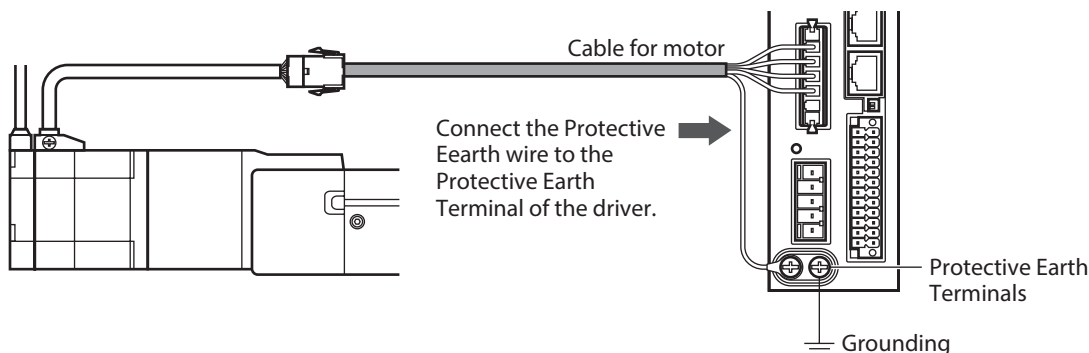

- memo**
- Ground the Protective Earth Terminal of the motor if the grounding resistance required by the applicable standard of the equipment is not satisfied.

#### 2) Grounding the Protective Earth Terminal of the motor

Ground the Protective Earth Terminal of the motor.

Use a round terminal when grounding, and make sure to secure with a screw and washer.

A grounding wire and a crimp terminal are not included.

- Conductor size: AWG18 (0.75 mm<sup>2</sup>) or thicker
- Screw size of Protective Earth Terminal: M4
- Tightening torque: 1.2 N·m (170 oz-in)

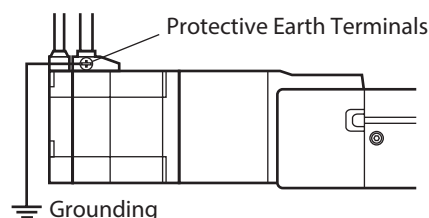

### ■ AR Series

Protective earth is not required for DC power input type actuators.  
 Ground the functional earth terminal (M4) if necessary.  
 Ground the Protective Earth Terminal of the motor for AC power input type actuators.

Use a round terminal when grounding, and make sure to secure with a screw and washer.

A grounding wire and a crimp terminal are not included.

- Conductor size: AWG18 (0.75 mm<sup>2</sup>) or thicker
- Screw size of Protective Earth Terminal: M4
- Tightening torque: 1.2 N·m (170 oz-in)

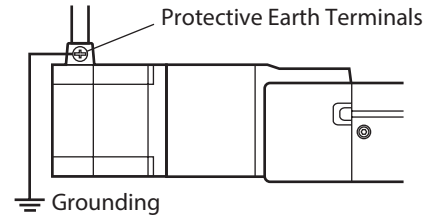

## 6-3 Connect the sensor

Installation method of our sensor set and connection example of the driver are explained here. Refer to the operating manual of the driver for details on signals and connections.

### ■ Sensor set description

The following parts are used for the sensor set.

Sensor set model	Sensor output	Photomicrosensor model
<b>PAES-S</b>	NPN	EE-SX674A (OMRON Corporation)
<b>PAES-SY</b>	PNP	EE-SX674R (OMRON Corporation)

- Sensor ..... 3 pieces
- Flexible cable with connector [2 m (6.6 ft.)]..... 3 pieces [Model: EE-1010-R (OMRON Corporation)]
- Sensor mounting bracket..... 3 pieces
- Shielded plate..... 1 piece
- Hexagonal socket head screw (M3) ..... 12 pieces
- Hexagonal socket head screw (M2.5)..... 2 pieces
- Hexagonal nut (M3)..... 6 pieces

### ■ Recommended sensor installation position

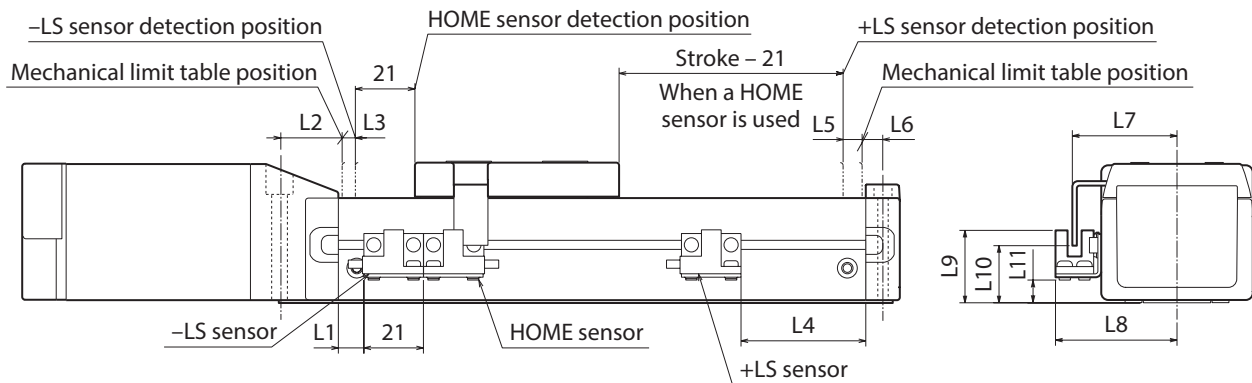

Motorized linear slides	L1	L2	L3	L4	L5	L6	L7	L8	L9	L10	L11
<b>EZSM3</b>	9	18	5	44	6	7.5	37.3	43.3	25.8	20.4	8.1
<b>EZSM4</b>	9	18	5	44	6	7.5	47.3	53.3	25.8	20.4	8.1
<b>EZSM6</b>	13.5	34	7	87.5	8	13.5	47.3	53.3	42.3	36.9	24.6

Unit: mm

- Up to two sensors can be installed to the motorized linear slide with a stroke of 60 mm or less.
- The sensor and shielded plate can be installed on the side opposite to the one shown in figure.

## ■ Mounting method

### ⚠ CAUTION

Do not install the sensor set while the power is being supplied. Doing so may result in injury or damage to equipment.

### Note

- Be sure to install the sensor and shielding plate in the direction shown in the figure. Installing them in the wrong direction may disable sensor detection or cause the shielding plate to contact the sensor, resulting in sensor damage.
- Do not connect or disconnect the flexible cable with connector while the power is supplied. It may damage the sensor.

### memo

- When installing the sensor mounting bracket and shielding plate to the motorized linear slide, be sure to use the included screws.
- When removing the flexible cable with connector from the sensor, do not pull the cable.

1. Secure the sensor to the sensor bracket using the included hexagonal socket head screws (M3: 2 pieces).  
Tightening torque: 0.6 N·m (85 oz-in)

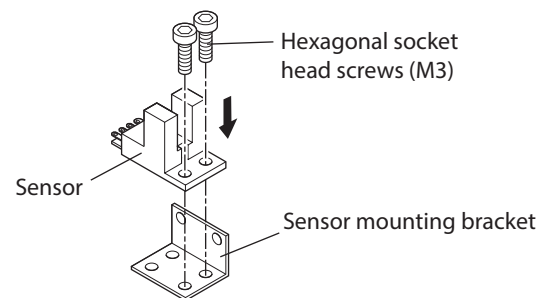

2. Temporarily secure the included hexagonal socket head screws (M3: 2 pieces) and hexagonal nuts (M3: 2 pieces) to the sensor mounting bracket.

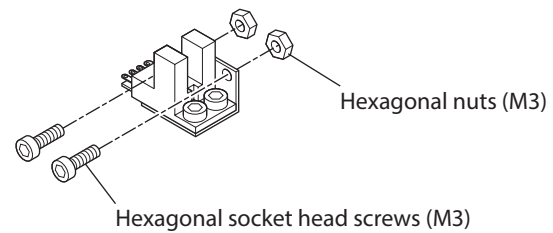

3. Insert the temporarily secured hexagonal nuts into the sensor rail, and tighten the hexagonal socket head screws.

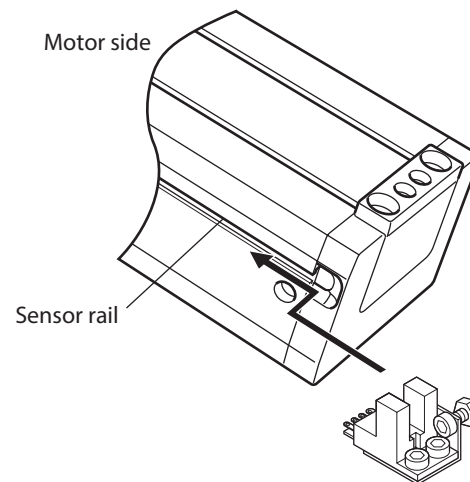

4. Connect the flexible cable with connector to the sensor.

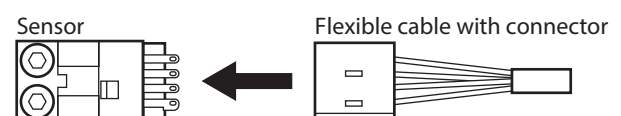

- Secure the shielded plate to the table using the included hexagonal socket head screws (M2.5: 2 pieces).  
Tightening torque: 0.6 N·m (85 oz-in)

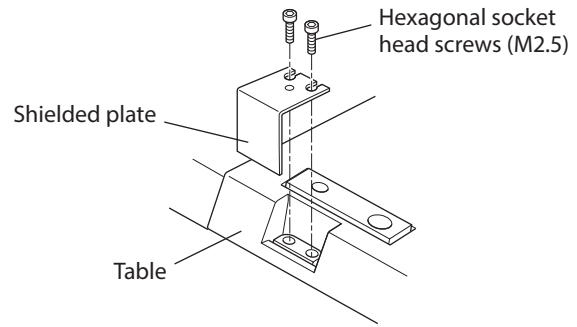

- The photomicrosensor is designed for use inside equipment and therefore has no special means of protection against disturbance light. If the actuator is to be used under an incandescent lamp or in conditions that are subject to disturbances from external light, provide the means to prevent such interference.
- Use the product after checking the sensor is installed securely.
- Place the power cables such as the motor cable or power supply cable as far apart as possible from the sensor cable. If the power cables and sensor cable have to cross, cross them at a right angle.
- To prevent sensor deterioration due to temperature, operate the actuator under the following conditions.
  - Actuators equipped with the **AZ** Series: Ambient operating temperature 0 to +40 °C (+32 to +104 °F), motor surface temperature 80 °C (176 °F) or lower
  - Actuators equipped with the **AR** Series: Ambient operating temperature 0 to +40 °C (+32 to +104 °F), motor surface temperature 90 °C (194 °F) or lower
- Adhesion of dust on the sensor may cause actuator malfunction. Clean and/or replace the sensor regularly.
- Use a common GND for the sensor power and user's controller power. Any difference in GND potential will result in a sensor malfunction.

### ■ Connection example for the sensor set PAES-S (NPN output)

The connection example is shown based on the following conditions.

- Home-seeking mode: 3 sensor mode
- Logic of +LS output and -LS output: Normally closed
- Logic of HOMES output: Normally open

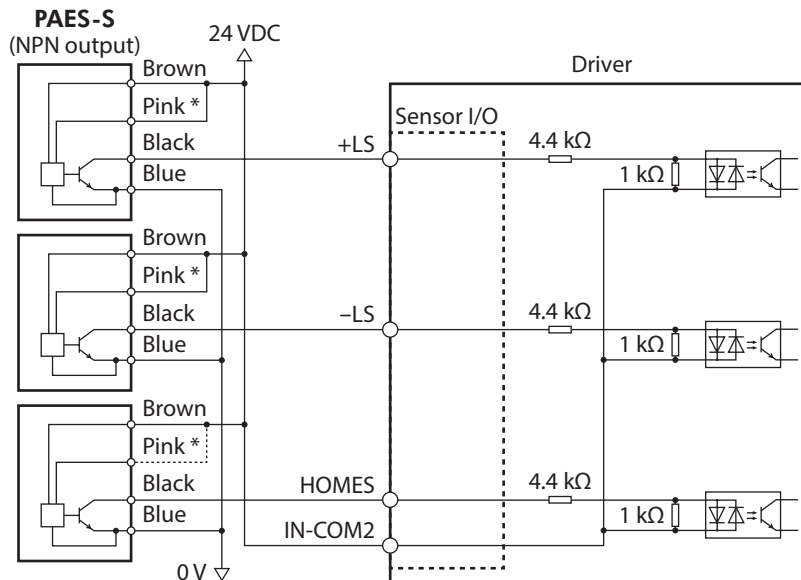

\* The logic of the sensor varies depending on the connection method. When the pink color lead is connected to the brown color lead, the sensor logic will be "normally closed."



If the wiring of the sensor exceeds 2 m (6.6 ft.), insert an electrolytic capacitor (10 μF, 50 V) within 2 m (6.6 ft.) of the sensor.

### ■ Connection example for the sensor set PAES-SY (PNP output)

The connection example is shown based on the following conditions.

- Home-seeking mode: 3 sensor mode
- Logic of +LS output and -LS output: Normally closed
- Logic of HOMES output: Normally open

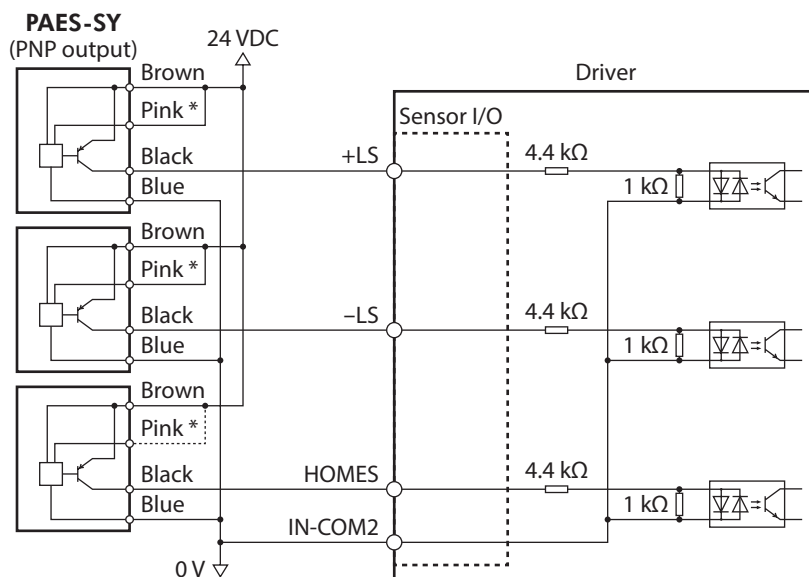

\* The logic of the sensor varies depending on the connection method. When the pink color lead is connected to the brown color lead, the sensor logic will be "normally closed."

**memo** If the wiring of the sensor exceeds 2 m (6.6 ft.), insert an electrolytic capacitor (10  $\mu$ F, 50 V) within 2 m (6.6 ft.) of the sensor.

# 7 Maintenance

This chapter explains the maintenance items in order to operate motorized linear slide safely and efficiently. If an abnormal condition is noted on the motorized linear slide, discontinue any use and contact your nearest Oriental Motor sales office.

## 7-1 Inspection item and timing

If the motorized linear slide is operated eight hours a day, perform maintenance according to the applicable period specified in the table below. Reduce maintenance intervals accordingly if the operating rate is high such as continuous operation for 24 hours.

Maintenance timing	External inspection	External cleaning	Internal inspection
When operated for the first time	✓	–	–
Six months after initial operation	✓	–	✓
Every six months thereafter	✓	–	✓
As needed	–	✓	–

### ■ External inspection

Check the items specified in table below.

Item	Description	Remedial action
Motorized linear slide	<ul style="list-style-type: none"> <li>• Check if any of the screws having installed the motorized linear slide is loose.</li> <li>• Check if any of the screws having installed a load is loose.</li> <li>• Check if any of the screws having installed a motor is loose.</li> </ul>	Tighten the screws securely.
	Check if any cracks or slacks is applied in the stainless steel sheet.	<ul style="list-style-type: none"> <li>• Replace the stainless steel sheet. For the stainless steel sheet for maintenance, contact your nearest Oriental Motor sales office.</li> <li>• Refer to p.36, and adjust the tension of the stainless steel sheet.</li> </ul>
Connector, cable	<ul style="list-style-type: none"> <li>• Check if a damage or stress is applied on the cable.</li> <li>• Check if the connection part between the motorized linear slide and driver is loose.</li> </ul>	<ul style="list-style-type: none"> <li>• Replace the cable.</li> <li>• Connect the connector again.</li> </ul>
Operation	Check if an unusual noise or vibration is generated from a bearing part (ball bearings).	Check the load mounting condition and operating speed.

### ■ External cleaning

- Wipe off any dirt and stains using a soft cloth. To remove stubborn stains, wipe the area using a soft cloth moistened with neutral detergent.
- Do not apply compressed air. Dust may enter through gaps.
- Do not use petroleum solvents, since they will damage the coated surface.

### Internal inspection

Visually check the internal condition of the motorized linear slide. Check the items specified in table below. Even if the grease has turned brown, lubrication condition is deemed appropriate if the running surface still appears glossy. Refer to "7-2 Applying grease" for how to apply grease.

Item	Description	Remedial action
Ball screw	Are there any deposits of foreign matter such as dust?	Remove the foreign matter.
	Has the grease lost its gloss or been consumed?	Clean the ball screw with a soft cloth and apply grease to the nut running groove.
Guide rail	Are there any deposits of foreign matter such as dust?	Remove the foreign matter.
	Has the grease lost its gloss or been consumed?	Clean the ball rolling grooves on both sides of the guide rail with a soft cloth and apply grease to the ball rolling grooves.

## 7-2 Applying grease

Detach the side cover, and apply grease referencing the re-greasing interval in the table below.

Grease application position	Re-greasing interval	Type of grease	Grease amount
Ball screw	<ul style="list-style-type: none"> <li>• Every six months</li> <li>• Every 100 km (62 mi.) in mileage</li> </ul>	• AFF Grease (THK CO., LTD.)	Apply grease so as to spread it over the traveling surface. Wipe off excess grease.
		• Models for clean room use • AFE-CA Grease (THK CO., LTD.)	
Guide rail	• When grease becomes extremely dirty	• AFF Grease (THK CO., LTD.)	

### CAUTION

- Wear protective goggles when applying grease. Pay attention to safety and handle the grease carefully by following the instructions provided with that product. If grease gets into the eyes or comes in contact with the skin, immediately flush the area thoroughly with water.
- When applying grease, do not touch the end section of the stainless steel sheet with bare hands. Doing so may result in injury.

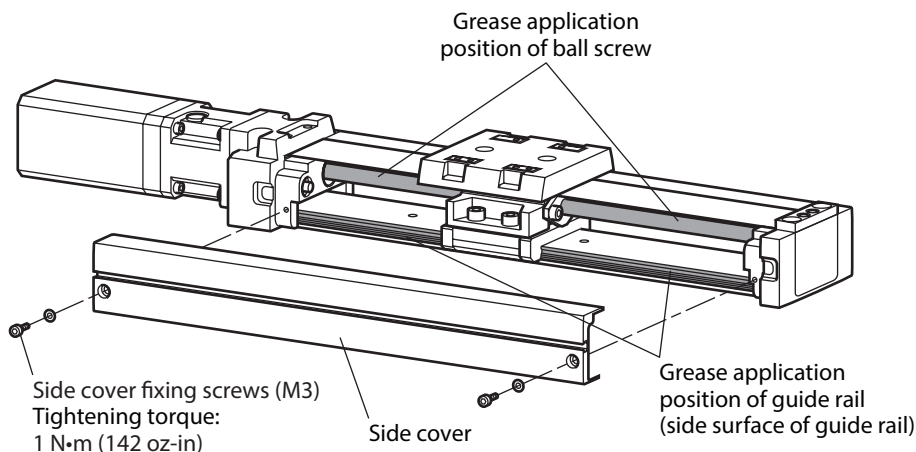

## 7-3 Checking the belt (Parallel motor mounting type)

Detach the pulley cover, and check the belt condition according to the items in the table below. As the result of checking, replace the belt if abnormality is detected. Refer to p.31 for how to replace the belt.

Inspection interval	Every 500 km (310 mi) in mileage
Inspection item	<ul style="list-style-type: none"> <li>• No crack on the belt rubber</li> <li>• No tooth chip on the belt</li> <li>• No abnormal wear on the tooth cloth of the belt</li> </ul>

### ■ Checking method

1. Remove the pulley cover fixing screws, and detach the pulley cover.

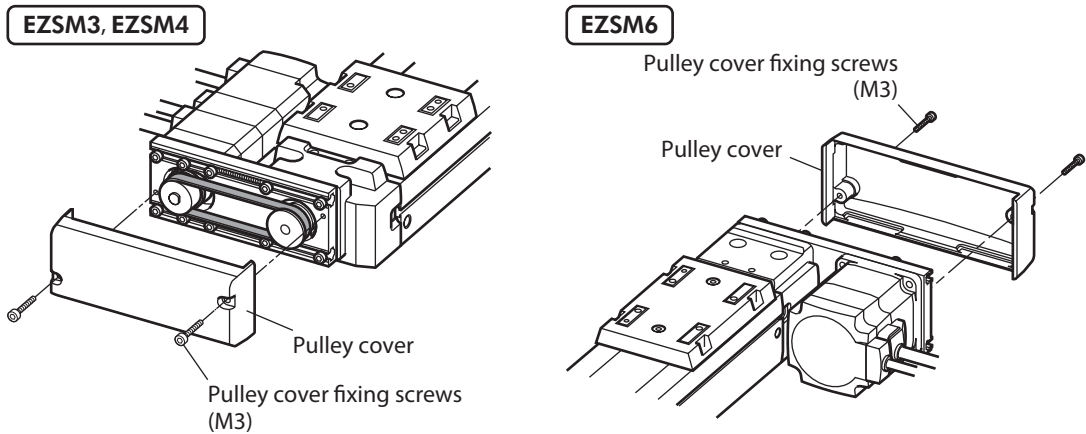

2. Check the the belt condition. And check the belt does not detach or protrude from the pulley.

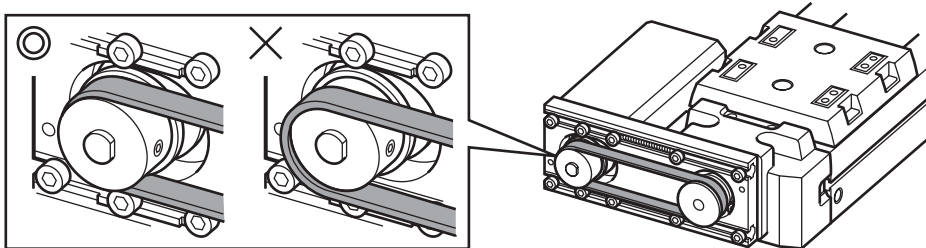

3. Attach the pulley cover, and tighten the screws.  
Tightening torque: 1 N·m (142 oz-in)

## 7-4 Adjusting the belt tension and replacing the belt

Adjust the belt tension of the parallel motor mounting type, or replace the belt.

### **⚠ WARNING**

- When adjusting the belt tension or replacing the belt, remove the load, and perform in a state where the motorized linear slide is placed in a horizontal position. Doing the operation in a vertical condition may allow the moving part to fall, leading to injury or mechanical damage.
- Set the home again after mounting a motor. If the motorized linear slide is operated without setting the home, the moving part may move to unexpected directions or run at unexpected speeds, leading to injury or mechanical damage.
  - The moving part of the motorized linear slide may collide with the mechanical stopper.
  - The load may collide with other equipment.

### ■ Belt for maintenance

For the belt for maintenance, contact your nearest Oriental Motor sales office.

Model	Belt model
<b>EZSM3, EZSM4</b>	<b>LS-LVCS2M060186</b>
<b>EZSM6</b>	<b>LS-LVCS3M080252</b>

### ■ Working procedure

This section explains about the **EZSM4** type as an example. With the **EZSM6** type, the motor mounting screws are located in the rear side of the motor.

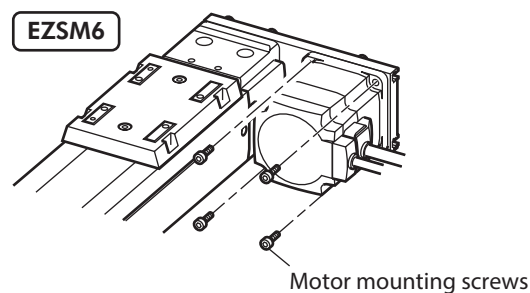
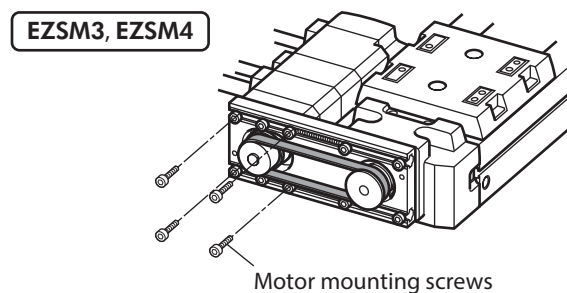

1. Remove the pulley cover fixing screws, and detach the pulley cover.

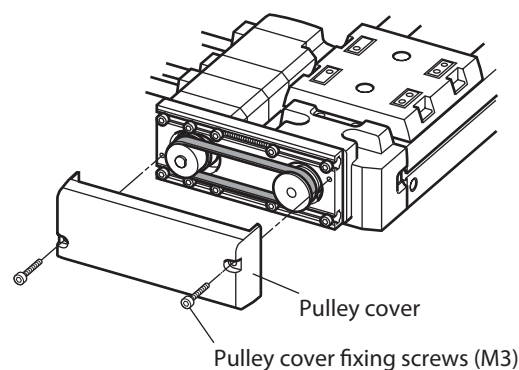

2. Loosen the motor mounting screws.

Model	Nominal size
<b>EZSM3, EZSM4</b>	M3
<b>EZSM6</b>	M4

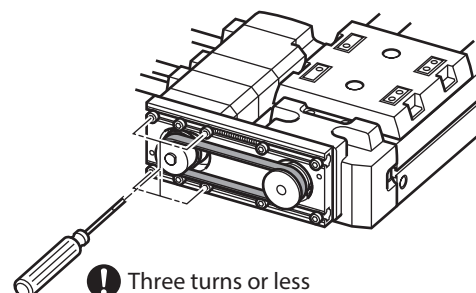

To prevent the motor mounting screw from falling off, keep three turns or less when turning the screw.

- Loosen the tension adjustment screws.  
When loosening the screws, tension of the belt will be adjusted properly by the strength of springs.

Model	Nominal size
<b>EZSM3, EZSM4</b>	M3
<b>EZSM6</b>	M4

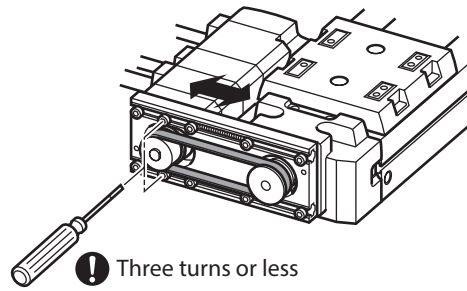

! Three turns or less

**memo** To prevent the tension adjustment screw from falling off, keep three turns or less when turning the screw.

- When replacing the belt, remove it while pressing the motor to the linear slide side. In addition, even when installing a new belt, do so while pressing the motor.

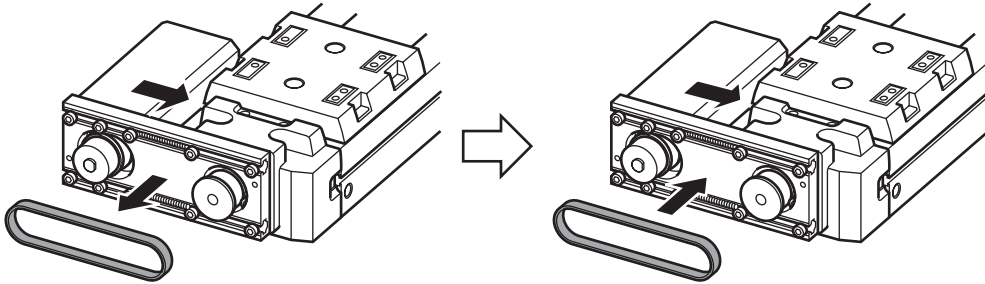

- Tighten the motor mounting screws with pressing the motor in the direction of arrow so that the motor does not tilt.

Model	Tightening torque
<b>EZSM3, EZSM4</b>	1 N·m (142 oz-in)
<b>EZSM6</b>	2.4 N·m (340 oz-in)

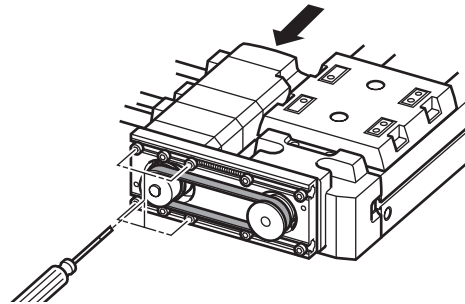

- Tighten the tension adjustment screws.

Model	Tightening torque
<b>EZSM3, EZSM4</b>	1 N·m (142 oz-in)
<b>EZSM6</b>	2.4 N·m (340 oz-in)

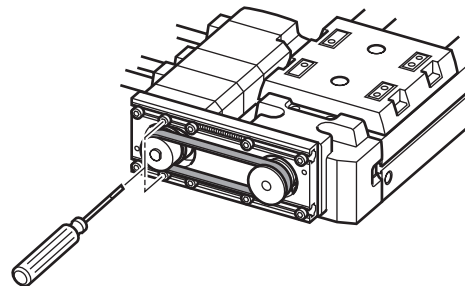

- Attach the pulley cover, and tighten the screws.  
Tightening torque: 1 N·m (142 oz-in)
- After mounting the motor, set the home again.

## 7-5 Replacing the motor

### **⚠️ WARNING**

- When replacing the motor, remove the load, and perform in a state where the motorized linear slide is placed in a horizontal position. Doing the operation in a vertical condition may allow the moving part to fall, leading to injury or mechanical damage.
  - If the motor mounting screws are removed in a state where the motorized linear slide is installed vertically, the motor may rotate rapidly. Thereby, fingers may be caught in the product or the cable may be disconnected.
- Set the home again after mounting a motor. If the motorized linear slide is operated without setting the home, the moving part may move to unexpected directions or run at unexpected speeds, leading to injury or mechanical damage.
  - The moving part of the motorized linear slide may collide with the mechanical stopper.
  - The load may collide with other equipment.
- Be sure to secure the coupling or pulley with the specified tightening torque. Unless it is secured with the specified torque, the ball screw may rotate idly, leading to injury or mechanical damage.
  - When the motorized linear slide is used in a vertical condition, the load may fall.
  - When the motorized linear slide is used in a horizontal condition, the moving part of the motorized linear slide may collide with the mechanical stopper. Also, the load may collide with other equipment.
- If the motor for the motorized linear slide equipped with the **AZ** Series is replaced, restore using the recovery data file. Replacing the motor only will not set the optimal parameters to the driver, so the motorized linear slide may move to unexpected directions or run at unexpected speeds, leading to injury or damage to equipment. For details, refer to the **AZ** Series OPERATING MANUAL Function Edition.

### ■ In-line motor mounting type

Refer to "In-line motor mounting type" on p.18, replace the motor.

If the motor for the motorized linear slide equipped with the **AZ** Series was replaced, set the home again after restoring with the recovery data file.

### ■ Parallel motor mounting type

This section explains about the **EZSM4** type as an example. With the **EZSM6** type, the motor mounting screws are located in the rear side of the motor.

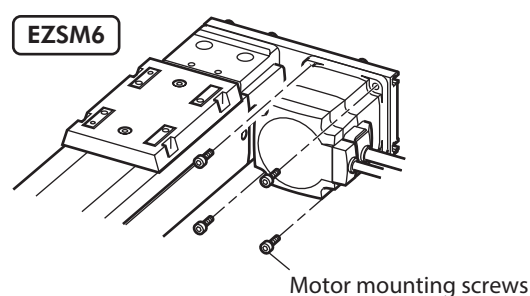
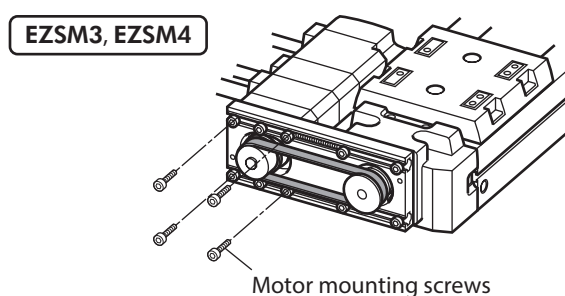

### ● Pulley for maintenance

If the motor of the parallel motor mounting type is replaced, purchase the pulley together with the motor. For details, contact your nearest Oriental Motor sales office.

Model	Pulley model
<b>EZSM3, EZSM4</b>	<b>LS-LSPTP1709</b>
<b>EZSM6</b>	<b>LS-LSPTP1710</b>

● Replacement procedure

1. Remove the pulley cover fixing screws, and detach the pulley cover.

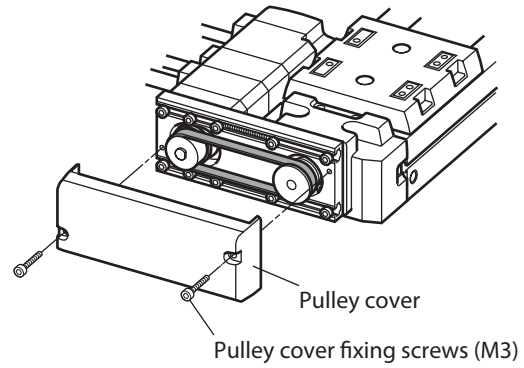

2. Remove the motor mounting screws.

Model	Nominal size
<b>EZSM3, EZSM4</b>	M3
<b>EZSM6</b>	M4

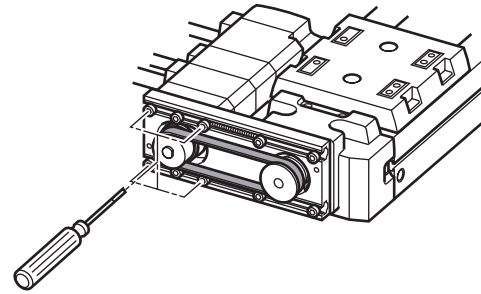

3. Dismount the motor and remove the belt.

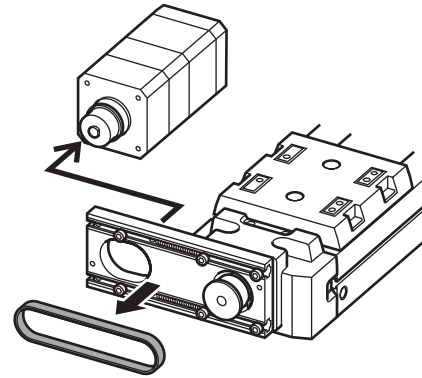

4. Install the pulley for maintenance to the new motor, and tighten the screws.

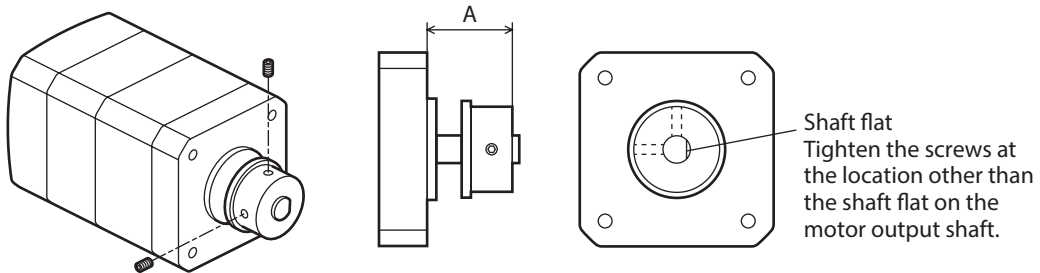

Model	A	Nominal size	Tightening torque
<b>EZSM3, EZSM4</b>	18.5 mm	M3	0.8 N•m (113 oz-in)
<b>EZSM6</b>	20.5 mm	M4	1.7 N•m (240 oz-in)

5. Mount the motor and install the belt, and tentatively fix the motor mounting screws.  
Tentatively fix the screws in a degree to be able to move the motor when touching it.

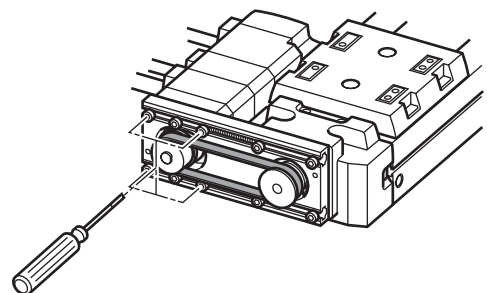

6. Loosen the tension adjustment screws.  
When loosening the screws, tension of the belt will be adjusted properly by the strength of springs.

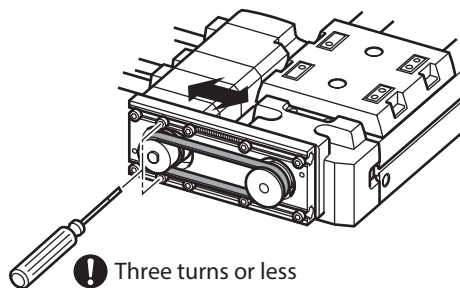

**memo** To prevent the tension adjusting screws from falling off, keep three turns or less when turning the screw.

7. Tighten the motor mounting screws with pressing the motor in the direction of arrow so that the motor does not tilt.

Model	Tightening torque
<b>EZSM3, EZSM4</b>	1 N·m (142 oz-in)
<b>EZSM6</b>	2.4 N·m (340 oz-in)

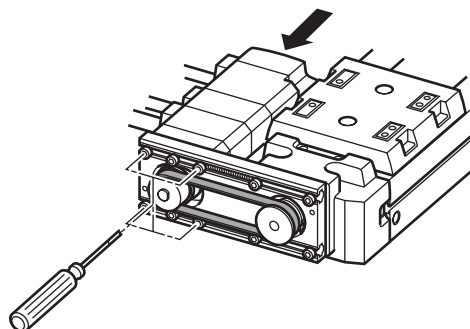

8. Tighten the tension adjustment screws.

Model	Tightening torque
<b>EZSM3, EZSM4</b>	1 N·m (142 oz-in)
<b>EZSM6</b>	2.4 N·m (340 oz-in)

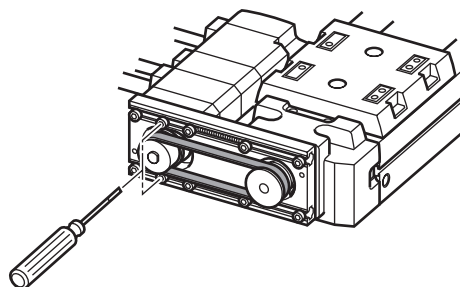

9. Attach the pulley cover, and tighten the screws.  
Tightening torque: 1 N·m (142 oz-in)
10. After mounting the motor, set the home again.  
If the motor for the motorized linear slide equipped with the **AZ** Series was replaced, set the home again after restoring with the recovery data file.

## 7-6 Adjusting the tension of the stainless steel sheet

If the stainless steel sheet is slacked, tighten and take up the slack of the stainless steel sheet.

### CAUTION

Do not touch the end section of the stainless steel sheet with bare hands. Doing so may result in injury.

1. Loosen the screw A or B.  
Screw A: M3 Hexagonal socket head screw (2 pieces)  
Screw B: M5 Hexagonal socket set screw (2 pieces)

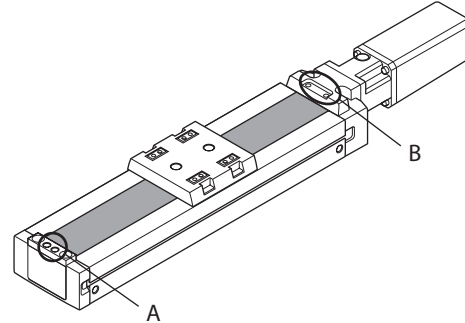

2. Pull the stainless steel sheet in the direction of the arrow while holding down it by hand to take up its slack.

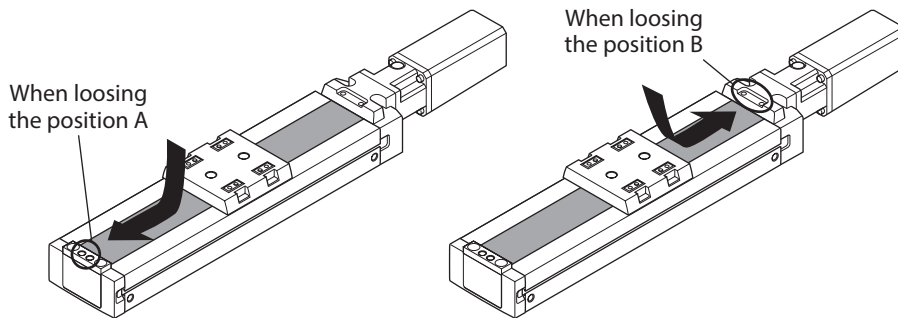

3. Tighten the screws.  
Tightening torque: 1 N·m (142 oz-in)
4. Move the table manually and check that there is no slack in the stainless steel sheet.

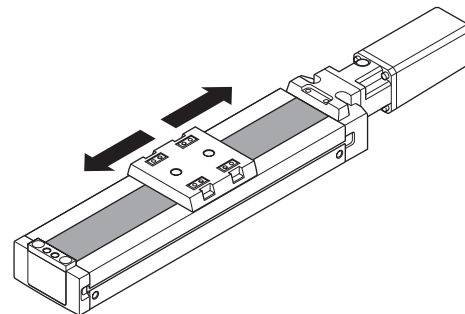

## 7-7 Warranty

Check on the Oriental Motor Website for the product warranty.

## 7-8 Disposal

Dispose the product correctly in accordance with laws and regulations, or instructions of local governments.

# 8 Standards, general specifications

## 8-1 Standards

### ■ Actuators equipped with the AZ Series

#### ● UL Standards, CSA Standards

For recognition information about UL Standards of the motor with which the actuator is equipped, check the "APPENDIX UL Standards" of product.

#### ● CE Marking / UKCA Marking

- EU Low Voltage Directive / UK Electrical Equipment (Safety) Regulation

The AC input type motor with which the actuator is equipped is affixed with the marks under the EU Low Voltage Directive / UK Electrical Equipment (Safety) Regulation.

- EU EMC Directive / UK EMC Regulation

The EMC test is conducted in a state where the equipped motor is connected to the driver. The driver that is combined with the motorized linear slide complies with the EMC Directive/Regulations. Refer to the operating manual of the driver for details.

- EU RoHS Directive / UK RoHS Regulations

This product does not contain the substances exceeding the restriction values.

#### ● Machinery Directive

The motorized linear slide and driver are designed and manufactured to be incorporated in general industrial equipment, and a Declaration of Incorporation of Partly Completed Machinery is issued with them according to the Machinery Directive.

### ■ Actuator equipped with the AR Series

#### ● UL Standards, CSA Standards

For recognition information about UL Standards of the motor with which the actuator is equipped, check the "APPENDIX UL Standards" of each product.

#### ● CE Marking

- Low Voltage Directive

The AC input type motor with which the actuator is equipped is affixed with the CE Marking under the Low Voltage Directive.

- EMC Directive

The EMC test is conducted in a state where the equipped motor is connected to the driver. The driver that is combined with the motorized linear slide complies with the EMC Directive. Refer to the operating manual of the driver for details.

- RoHS Directive

This product does not contain the substances exceeding the restriction values.

#### ● Machinery Directive

The motorized linear slide and driver are designed and manufactured to be incorporated in general industrial equipment, and a Declaration of Incorporation of Partly Completed Machinery is issued with them according to the Machinery Directive.

## 8-2 Specifications

Check on the Oriental Motor Website for the product specifications.

## 8-3 General specifications

### ■ Installation conditions

The product is designed and manufactured to be incorporated in general industrial equipment.

Input power supply	DC power supply	AC power supply
Overvoltage category	II	
Protection against electric shock	Class III	Class I
Pollution degree	2	3
Degree of protection	IP20	
Noise level	72 dB	

### ■ Environmental conditions

	Operating environment	Storage environment Shipping environment
Ambient temperature	0 to +40 °C [+32 to +104 °F] (non-freezing)	-20 to +60 °C [-4 to +140 °F] (non-freezing)
Ambient humidity	85 % or less (non-condensing)	
Altitude	Up to 1,000 m (3,300 ft.) above sea level	Up to 3,000 m (10,000 ft.) above sea level

# 9 Accessories

---

## ■ Sensor sets

Sensor set model	Applicable product	Sensor output
PAES-S	EZSM3, EZSM4, EZSM6	NPN
PAES-SY		PNP

- Unauthorized reproduction or copying of all or part of this Operating Manual is prohibited.  
If a new copy is required to replace an original manual that has been damaged or lost, please contact your nearest Oriental Motor branch or sales office.
- Oriental Motor shall not be liable whatsoever for any problems relating to industrial property rights arising from use of any information, circuit, equipment or device provided or referenced in this manual.
- Characteristics, specifications and dimensions are subject to change without notice.
- While we make every effort to offer accurate information in the manual, we welcome your input. Should you find unclear descriptions, errors or omissions, please contact the nearest office.
- **Orientalmotor** and ABZO sensor are registered trademarks or trademarks of Oriental Motor Co., Ltd., in Japan and other countries.

Other product names and company names mentioned in this manual may be registered trademarks or trademarks of their respective companies and are hereby acknowledged. The third-party products mentioned in this manual are recommended products, and references to their names shall not be construed as any form of performance guarantee. Oriental Motor is not liable whatsoever for the performance of these third-party products.

© Copyright ORIENTAL MOTOR CO., LTD. 2015

Published in March 2026

- Please contact your nearest Oriental Motor office for further information.

ORIENTAL MOTOR U.S.A. CORP.  
Technical Support Tel:800-468-3982  
8:30am EST to 5:00pm PST (M-F)

ORIENTAL MOTOR (EUROPA) GmbH  
Schiessstraße 44, 40549 Düsseldorf, Germany  
Technical Support Tel:00 800/22 55 66 22

ORIENTAL MOTOR (UK) LTD.  
Blythe Valley Business Park,  
Central Blvd Blythe Valley Park,  
Solihull B90 8AG, United Kingdom  
Tel:+44-1926-671220

ORIENTAL MOTOR (FRANCE) SARL  
Tel:+33-1 47 86 97 50

ORIENTAL MOTOR ITALIA s.r.l.  
Tel:+39-02-93906347

ORIENTAL MOTOR ASIA PACIFIC PTE. LTD.  
Singapore  
Tel:1800-842-0280

ORIENTAL MOTOR (MALAYSIA) SDN. BHD.  
Tel:1800-806-161

ORIENTAL MOTOR (THAILAND) CO., LTD.  
Tel:1800-888-881

ORIENTAL MOTOR (INDIA) PVT. LTD.  
Tel:1800-120-1995 (For English)  
1800-121-4149 (For Hindi)

TAIWAN ORIENTAL MOTOR CO., LTD.  
Tel:0800-060708

SHANGHAI ORIENTAL MOTOR CO., LTD.  
Tel:400-820-6516

INA ORIENTAL MOTOR CO., LTD.  
Korea  
Tel:080-777-2042

ORIENTAL MOTOR CO., LTD.  
4-8-1 Higashiueno, Taito-ku, Tokyo  
110-8536 Japan  
Tel:+81-3-6744-0361  
[www.orientalmotor.co.jp/ja](http://www.orientalmotor.co.jp/ja)