

DGII Series Hollow Rotary Gearhead

OPERATING MANUAL

Table of contents

1	Introduction.....	2	8	Installing a load.....	14
2	Preparation	3	9	Connection.....	16
3	Safety precautions.....	4	10	Maintenance	18
4	Precautions for use	6	11	Regulations and standards	19
5	Mounting or dismounting the motor ..	7	12	Specifications	20
6	Check before installation	10	13	Accessories.....	21
7	Installing the product	11			

Thank you for purchasing an Oriental Motor product.
This Manual describes product handling procedures and safety precautions.

- Please read it thoroughly to ensure safe operation.
- Always keep the manual where it is readily available.

1 Introduction

1-1 Before use

Only qualified personnel of electrical and mechanical engineering should work with the product. Use the product correctly after thoroughly reading the "3 Safety precautions" on p.4. In addition, be sure to observe the contents described in warning, caution, and note in this manual. The product described in this manual is designed and manufactured to be incorporated in general industrial equipment. Do not use for any other purpose. Oriental Motor Co., Ltd. is not responsible for any compensation for damage caused through failure to observe this warning.

2 Preparation

This chapter explains the items you should check, as well as the name of each part.

2-1 Checking the product

Verify that the items listed below are included. Report any missing or damaged items to the Oriental Motor sales office from which you purchased the product.

- Hollow rotary gearhead

2-2 How to identify the product model

DGN 130 R 2 - 18
 1 2 3 4 5

1	Series name	DGN:DGII Series Hollow Rotary Gearhead
2	Frame size	85:85 mm 130:130 mm 170:170 mm 200:200 mm
3	Output table supporting bearing type	R: Cross-roller bearing
4	Reference number	
5	Gear ratio	18

2-3 Names of parts

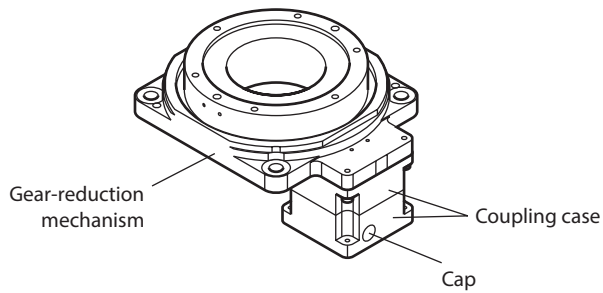

3 Safety precautions



The precautions described below are intended to ensure the safe and correct use of the product, and to prevent the customer and others from exposure to the risk of injury. Use the product only after carefully reading and fully understanding these instructions.

In regard to a hollow rotary gearhead (hereinafter referred to as gearhead), it is prohibited to start operating the gearhead (i.e., to operate the device in accordance with the specified purpose) when the machine in which the gearhead is incorporated does not satisfy any relevant safety standards.

The factory safety manager or safety personnel in charge of the applicable machine must ensure that the machine is operated only by qualified personnel who are familiar with the operation of electronic equipment, and thereby prevent injury or damage to the equipment.







The term "qualified personnel" refers to persons who have received the necessary training or education and have pertinent experience; who are familiar with the relevant standards, regulations, accident-prevention rules and inspection conditions; who are authorized by the factory safety manager to engage in the necessary activities; and who have the ability to discern and prevent potential dangers.

Description of signs

 WARNING	Handling the product without observing the instructions that accompany a "WARNING" symbol may result in death or serious bodily injury.
 CAUTION	Handling the product without observing the instructions that accompany a "CAUTION" symbol may result in bodily injury or property damage.
 Note	The items under this heading contain important handling instructions that the user should observe to ensure the safe use of the product.

Description of graphic symbols

	Indicates "prohibited" actions that must not be performed.		Indicates "compulsory" actions that must be performed.
---	--	---	--

 WARNING	
	<ul style="list-style-type: none"> • Do not use the product in explosive or corrosive environments, in the presence of flammable gases, in places subjected to splashing water, or near combustibles. Doing so may result in fire, electric shock, or injury. • Do not transport, install, connect or inspect the product while the power is supplied. Doing so may result in electric shock. • Do not disassemble or modify the product. Doing so may result in injury or damage to equipment. • Never use the product in a medical device used in connection with the maintenance or management of human life or health, or in a transportation system whose purpose is to move or carry people. • Be sure to provide a safety cage conforming to EN ISO 13857 to prevent persons from entering the moving range of the product while power is supplied to the product.
	<ul style="list-style-type: none"> • Assign qualified personnel to the task of installing, wiring, operating/controlling, inspecting and troubleshooting the product. Handling by unqualified personnel may result in fire, electric shock, injury, or damage to equipment. • Take measures to keep the moving part in position if the product is used in vertical operations such as elevating equipment. Failure to do so may result in injury or damage to equipment. • Install the products inside an enclosure in order to prevent electric shock or injury. • Provide an emergency stop device or emergency stop circuit external to the equipment so that the entire equipment will operate safely in the event of a system failure or malfunction. Failure to do so may result in injury.
 CAUTION	
	<ul style="list-style-type: none"> • Do not use the product beyond its specifications. Doing so may result in electric shock, injury or damage to equipment. • Keep your fingers and objects out of the openings in the product. Failure to do so may result in fire, electric shock or injury. • Do not touch the product during operation or immediately after stopping. Doing so may cause a skin burn(s). • Do not carry the product by holding its moving part. Doing so may cause injury. • Keep the area around the product free of combustible materials. Failure to do so may result in fire or a skin burn(s). • Leave nothing around the product that would obstruct ventilation. Failure to do so may result in damage to equipment. • Do not touch the moving part during operation. Doing so may cause injury. • Do not touch the terminals while conducting the insulation resistance measurement or dielectric strength test. Doing so may cause electric shock. • Do not use our home-sensor set as safety-related parts. Doing so may result in injury or equipment damage.
	<ul style="list-style-type: none"> • Wear a helmet, safety shoes, gloves or other protective gear when transporting or installing the product. Failure to do so may result in injury. • The product is very heavy. When transporting or installing the product, make sure two persons work together to carry out the necessary tasks. Failure to do so may result in injury. • When assembling the product and the motor, be careful not to get your fingers or any other part of your body caught between the product and the motor. Failure to do so may result in injury. • When handling grease, wear safety glasses and avoid touching it directly. If grease gets into eyes or comes in contact with the skin, immediately flush the area thoroughly with water.

4 Precautions for use

This chapter covers restrictions and requirements the user should consider when using the product.

■ General

- **Do not make an impact on the product.**

Do not drop the product. Also, do not hit the motor or gear-reduction mechanism on something hard. Doing so may cause the positioning accuracy decrease, the product damage or the product service life reduction.

■ Operation

- **Do not apply a moment load or axial load in excess of the specified permissible limit.**

Continuing to operate the product under an excessive moment load or axial load may damage the bearings of the product. Be sure to operate the product below the specified permissible limits of the moment load and axial load.

- **Hollow hole section**

If the pipe or cable installed in the hollow hole section is rotated together with the output table, take measures not to rub or disconnect in contact with the inner wall of the hollow hole section.

- **Do not perform an operation to cause overshooting or undershooting.**

Operating the product under the condition that overshooting or undershooting occurs may cause damage to the gear-reduction mechanism. Please review and adjust the operating conditions.

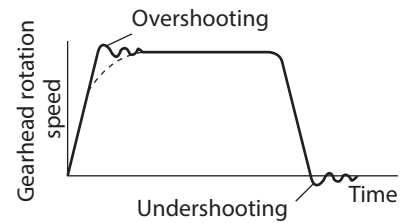

- **Rotating part of output table**

The red part in the figure rotates.

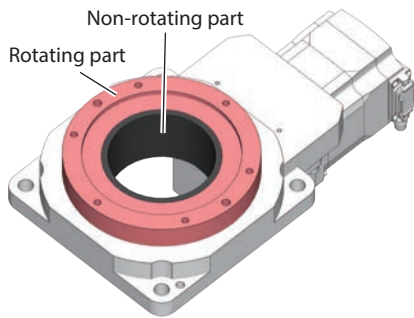

- **Rotation direction of output table**

The output table rotates in the opposite direction to the rotation direction of the motor output shaft.

5 Mounting or dismounting the motor

⚠ WARNING

- When changing the motor cable outlet direction, remove the load. Doing so in a condition where a load is installed may result in injury or damage to equipment.
- Set the home again after mounting a motor. If the product is operated without setting the home, the moving part may move to unexpected directions or run at unexpected speeds, leading to injury or mechanical damage.
 - The load may collide with other equipment.
- Be sure to secure the coupling with the specified tightening torque. If the coupling is not secured with the specified tightening torque, it may slip, causing the moving part to rotate in an unexpected direction or at an unexpected speed, resulting in injury or damage to equipment.
- Be sure to secure the motor mounting screws with the specified tightening torque. Unless it is secured with the specified torque, the moving part may move to unexpected directions or run at unexpected speeds, leading to injury or mechanical damage.

Note When mounting or dismounting the motor, do so with the gear-reduction mechanism facing down. Since the weight of the motor is applied to the coupling case, the gap can be eliminated. If there is a gap between the motor and the coupling case, it may cause abnormal noise or reduce the product life.

5-1 Mounting the motor

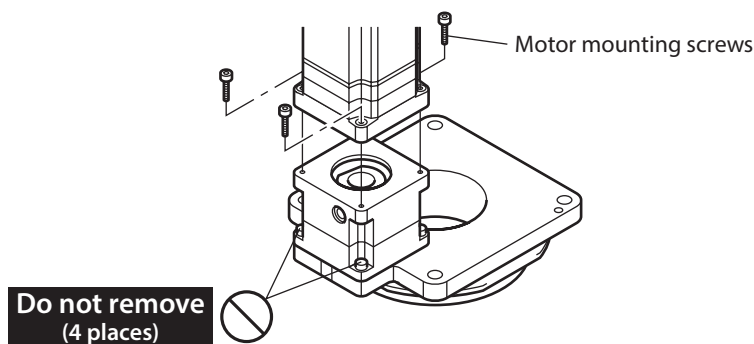

1. Mount the motor to the coupling case.
2. Tighten the coupling fixing screw.

Model	Tightening torque [N·m (oz-in)]
DGN85	2(280)
DGN130, DGN170	4.3(610)
DGN200	6(850)

3. Tighten the motor mounting screws.

Model	Nominal size	Number of screws	Mating length	Tightening torque [N·m (oz-in)]
DGN85	M4	4 pcs.	3 mm to 10 mm	1 (142)
DGN130, DGN170	M5	4 pcs.	5 mm to 8 mm	2 (280)
DGN200	M6	4 pcs.	10 mm	3 (420)

Note

- Wipe off any oil from the motor output shaft and the coupling bore before securing the motor.
- Do not touch the coupling with bare hands. This may cause rust.
- Do not use the ball-end hex key.
- Do not change the direction of the motor while it is fixed in the coupling.
- If an object is caught between the motor and the coupling case, or if the motor output shaft and the coupling are not aligned, there may be a gap. To prevent damage to the equipment, fix securely so that there is no gap between them.

4. Attach the cap

5-2 Dismounting the motor

1. Remove the cap and loosen the coupling fixing screw by three turns.

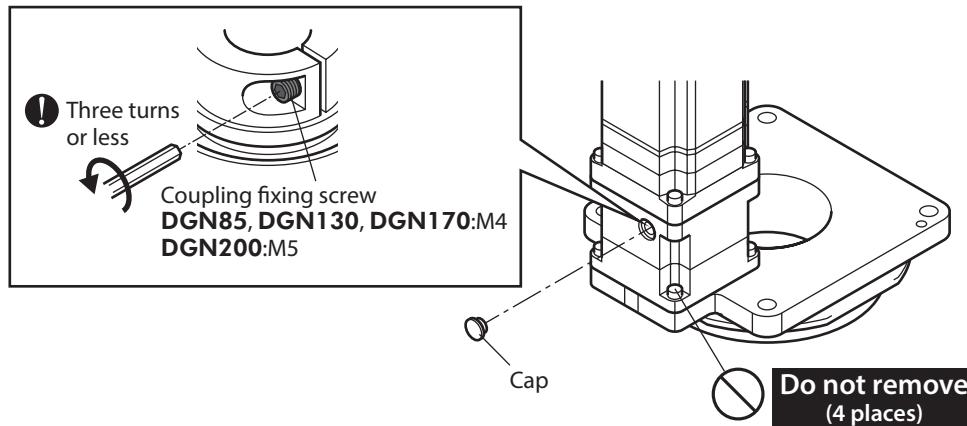

Note

- To prevent the coupling fixing screw from falling off, keep three turns or less when turning the screw.
- When loosening the coupling fixing screw, do not insert the tool diagonally.
- Do not use the ball-end hex key.

2. Remove the motor mounting screws, and dismount the motor.

6 Check before installation

6-1 Location for installation

The gearhead is designed and manufactured to be incorporated in general industrial equipment. Install it in a well ventilated location that provides easy access for inspection. The location must also satisfy the following conditions:

- Inside an enclosure that is installed indoors (provide vent holes)
- Operating ambient temperature : 0 to +40 °C (+32 to +104 °F) (Non-freezing)
- Operating ambient humidity: 85 % or less (non-condensing)
- Area free of explosive atmosphere, toxic gas (such as sulfuric gas), or liquid
- Area not exposed to direct sun
- Area free of excessive amount of dust, iron particles or the like
- Area not subject to splashing water (rain, water droplets), oil (oil droplets) or other liquids
- Area free of excessive salt
- Area not subject to continuous vibrations or excessive shocks
- Area free of radioactive materials, magnetic fields or vacuum
- Up to 1,000 m (3,300 ft.) above sea level

■ Installation direction

The product can be installed in any direction.

To prevent vibration, install the product on a metal surface of sufficient strength.



- On rare occasions, a small amount of grease may ooze out from the product. If there is concern over possible environmental damage resulting from the leakage of grease, check for grease stains during regular inspections. Alternatively, install an oil pan or other device to prevent leakage from causing further damage. Oil leakage may lead to problems in the user's equipment or products.
 - Be sure the positioning pins are secured to the mounting plate. Driving the pins into the product may damage the product due to impact.
 - Do not drop the product. Also, do not hit the motor or gear-reduction mechanism on something hard. Doing so may cause the positioning accuracy decrease, the product damage or the product service life reduction.
 - Do not loosen or remove the screws of the product. Doing so may cause the positioning accuracy to drop or damage to the product.
-

7 Installing the product

7-1 Specifications for mounting holes and positioning pin holes

The mounting holes are through holes. Provide screw hole machining in the mounting plate.

Values of the tightening torque are recommended. Tighten the screws with a suitable torque according to the design conditions of the mounting plate.

Model	Mounting hole			Positioning pin hole	
	Pin hole diameter	Nominal size	Tightening torque	Pin hole diameter	Pin hole depth
DGN85	ø6.5 mm (ø0.26 in.)	M6	6 N·m (53 lb-in)	$\varnothing 5^{+0.012}_0$ mm ($\varnothing 0.1969^{+0.0005}_0$ in.)	10.5 mm (0.41 in.), Through hole
DGN130	ø9 mm (ø0.35 in.)	M8	13 N·m (115 lb-in)	$\varnothing 5^{+0.012}_0$ mm ($\varnothing 0.1969^{+0.0005}_0$ in.)	12 mm (0.47 in.), Through hole
DGN170	ø10.5 mm (ø0.41 in.)	M10	25 N·m (220 lb-in)	$\varnothing 5^{+0.012}_0$ mm ($\varnothing 0.1969^{+0.0005}_0$ in.)	10 mm (0.39 in.), Through hole
DGN200	ø11 mm (ø0.43 in.)	M10	25 N·m (220 lb-in)	$\varnothing 8^{+0.015}_0$ mm ($\varnothing 0.3150^{+0.0006}_0$ in.)	8 mm (0.31 in.), Blind hole

Viewing from the motor side

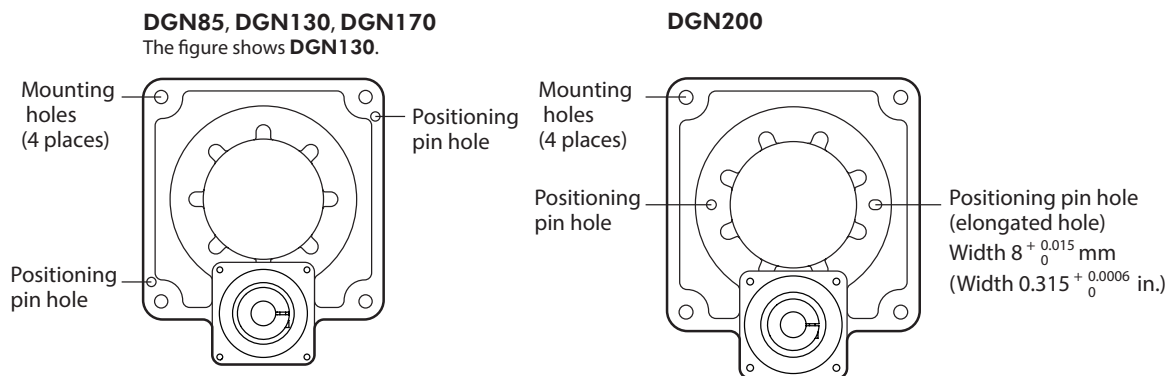

7-2 Installation method

- Design for mounting plate [reference] [unit: mm (in.)]

DGN85

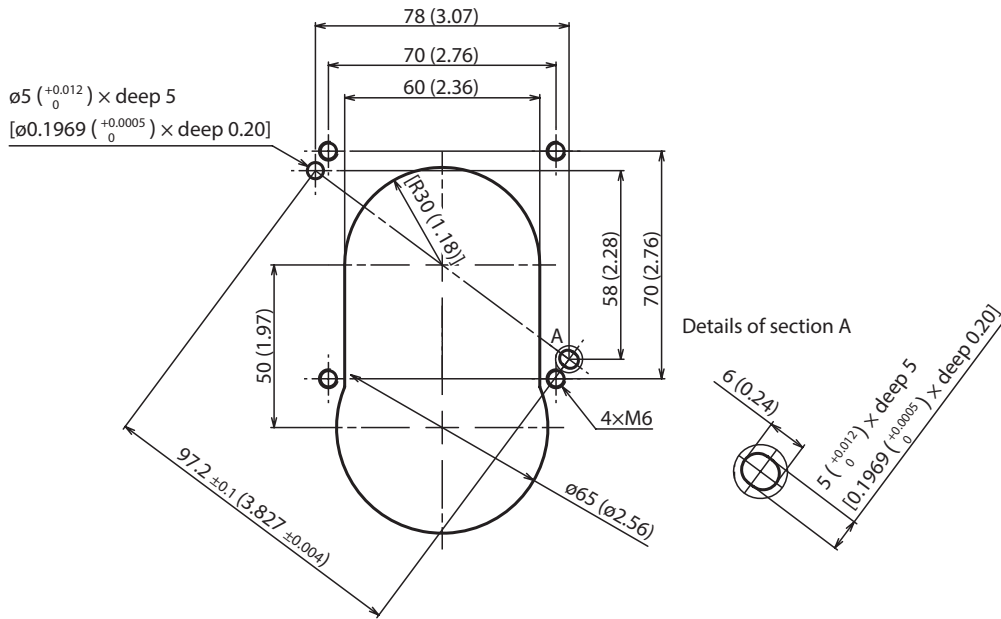

DGN130

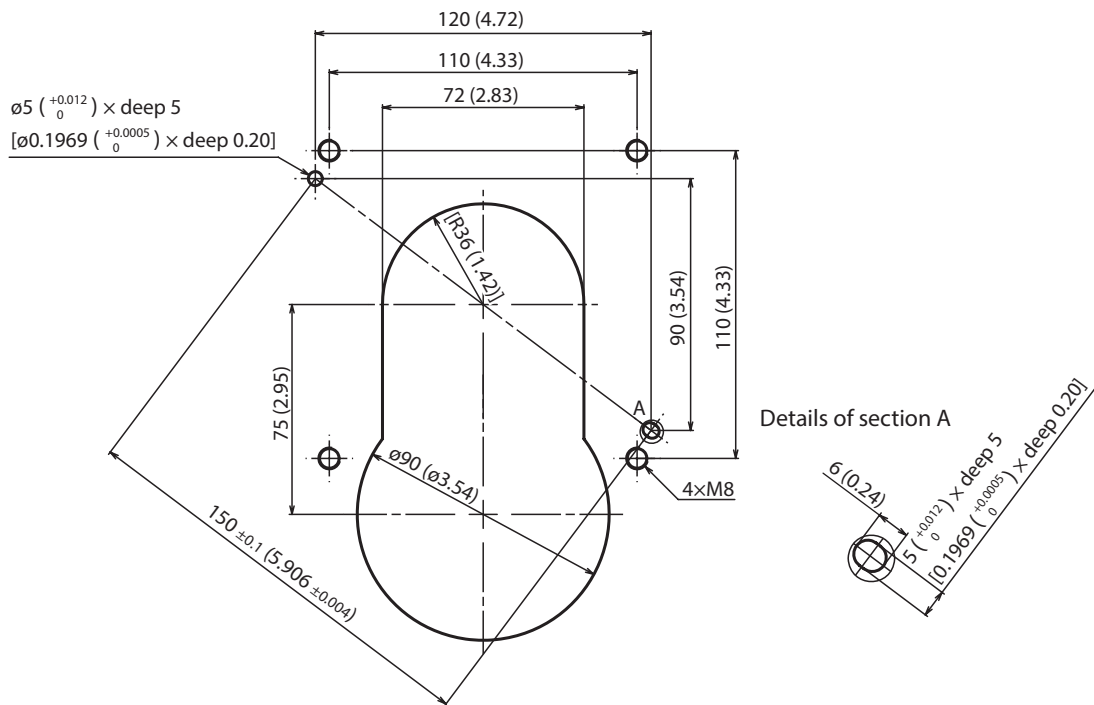

DGN170

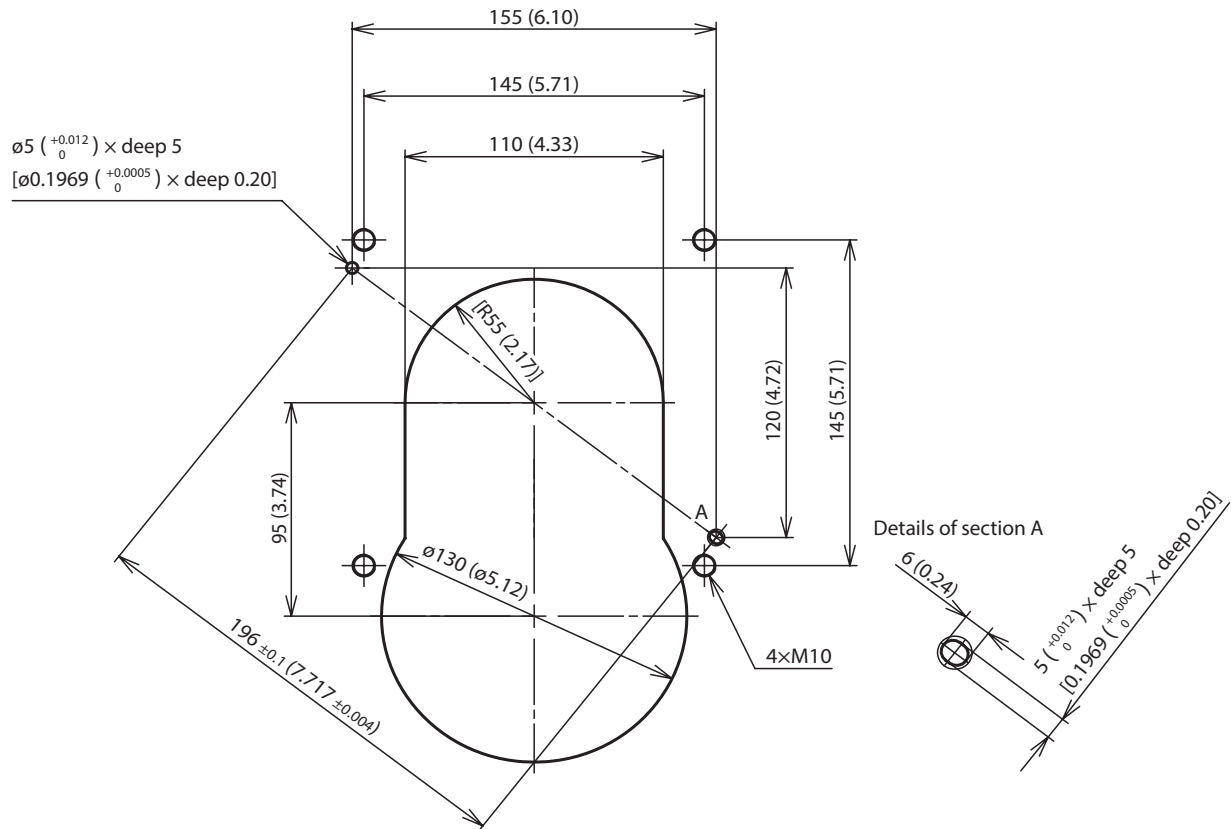

DGN200

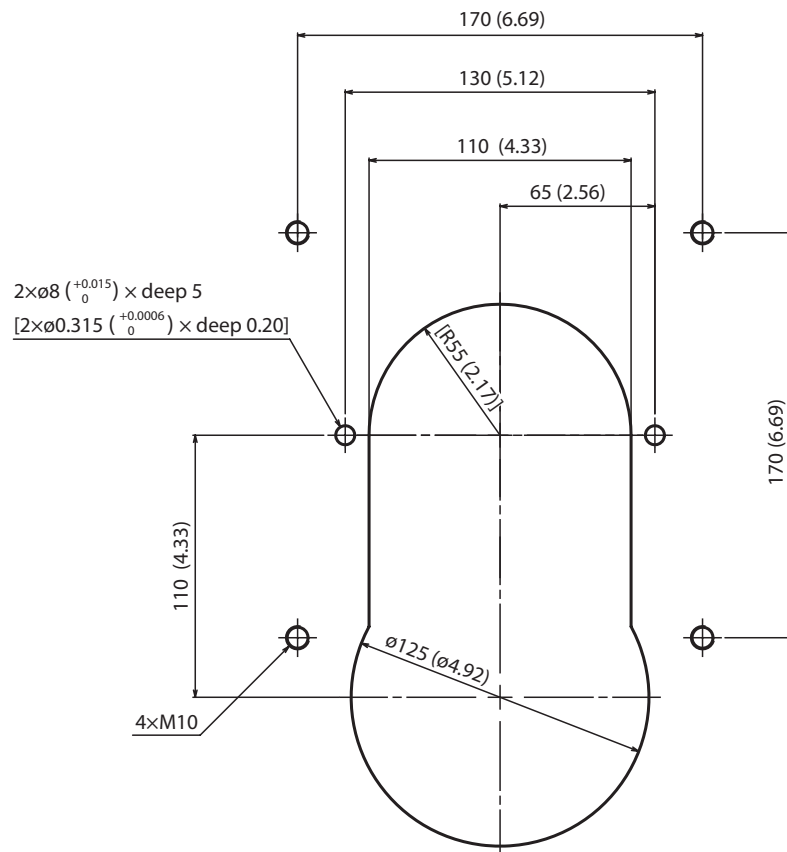

8 Installing a load

8-1 Specifications about installation

Install a load with screws using the load-mounting screw holes (six places) onto the output table.

Use the load-mounting pin holes (two places) of the output table when positioning a load.

Values of the tightening torque are recommended. Tighten the screws with a suitable torque according to the design conditions of the load.

Model	Nominal size	Tightening torque [N·m (oz-in)]	Effective depth of screw thread [mm (in.)]	Material of load	Pin hole diameter [mm (in.)]	Pin hole depth [mm (in.)]
DGN85	M4	2 (280)	8 (0.31)	Steel or aluminum	$\begin{matrix} \phi 5^{+0.012} \\ 0 \\ (\phi 0.1969^{+0.0005}) \end{matrix}$	6 (0.24)
DGN130	M5	3.5 (490)	8 (0.31)		$\begin{matrix} \phi 5^{+0.012} \\ 0 \\ (\phi 0.1969^{+0.0005}) \end{matrix}$	6 (0.24)
DGN170	M6	6 (850)	8 (0.31)		$\begin{matrix} \phi 5^{+0.012} \\ 0 \\ (\phi 0.1969^{+0.0005}) \end{matrix}$	6 (0.24)
DGN200	M6	6 (850)	10 (0.39)		$\begin{matrix} \phi 8^{+0.015} \\ 0 \\ (\phi 0.3150^{+0.0006}) \end{matrix}$	8 (0.31)

Note Be sure the positioning pins are secured to the load. Driving the pins into the output table may damage the bearing due to impact or an excessive moment of inertia.

8-2 Permissible moment, permissible axial load

Use the product so as not to exceed the permissible moment and the permissible axial load shown in the table. Calculate the axial load and load moment using the International System of Units (N, N·m).

Model	Output table supporting bearing	Permissible moment * (N·m)	Permissible axial load (N)
DGN85	Cross-roller bearing	40	500
DGN130	Cross-roller bearing	160	2,000
DGN170	Cross-roller bearing	300	3,000
DGN200	Cross-roller bearing	500	4,000

* This value is when the input rotation speed is 3,000 r/min.

■ When external force F is applied at distance L from the center of the output table

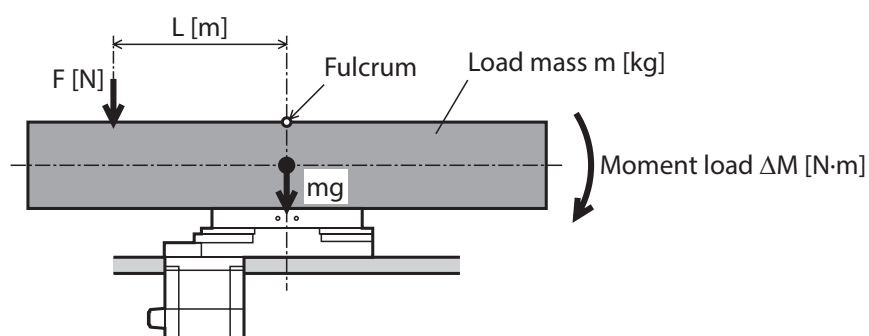

Moment load [N·m] : $\Delta M = F \times L$

Axial load [N] : $F_s = F + m$ (load mass) $\times g$ (gravitational acceleration)

■ When external forces F1 and F2 are applied at distance L from the mounting face of the output table

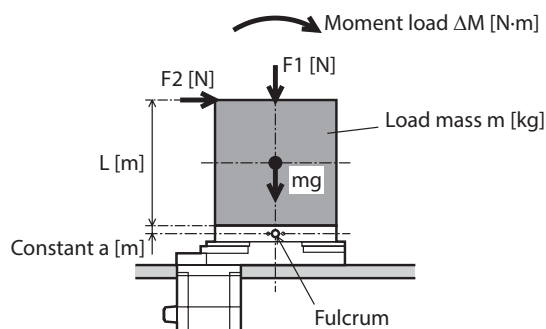

Moment load [N·m] : $\Delta M = F_2 \times (L + \text{constant } a)$

Axial load [N] : $F_s = F_1 + m$ (load mass) $\times g$ (gravitational acceleration)

Model	Constant a (m)
DGN85	0.014
DGN130	0.015
DGN170	0.016
DGN200	0.03

9 Connection

9-1 Connecting a home sensor

Installation method of our home-sensor set.

Note The home-sensor set cannot be used with **DGN85** and **DGN170**.

■ Home-sensor set description

The following parts are used for the home-sensor set.

Applicable product	Home-sensor set model	Sensor output	Photomicrosensor model
DGN130, DGN200	PADG-SB	NPN	EE-SX673A (OMRON Corporation)
	PADG-SBY	PNP	EE-SX673R (OMRON Corporation)

- Photomicrosensor..... 1 pc.
- Flexible cable with connector..... 1 pc. EE-1010-R (OMRON Corporation) length 2 m (6.6 ft.)
- Sensor mounting bracket..... 1 pc.
- Shielded plate..... 1 pc.
- Screw (M3, spring washer, plain washer)..... 2 pcs.
- Hexagonal socket head screw (M2.5)..... 4 pcs.

■ Installation method

CAUTION Do not install the home-sensor set while the power is being supplied. Doing so may result in injury or damage to equipment.

- Note**
- Be sure to install the sensor and shielded plate in the direction shown in the figure. Installing them in the wrong direction may disable sensor detection or cause the shielded plate to contact the sensor, resulting in sensor damage.
 - When installing the sensor bracket and shielded plate to the gearhead, be sure to use the included screws.

1. Secure the sensor to the sensor bracket using the included screws (M3×2).
Tightening torque: 0.6 N·m (85 oz-in)

The screw holes are provided on two places (right and left) of the sensor bracket. The sensor can be installed to either of the screw holes (right or left).

Install it to the position in which an indicating light can be seen.

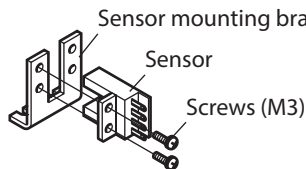

- Secure the mounting bracket with the sensor attached as shown in the illustration using the included hexagonal socket head screws (M2.5×2).
Tightening torque: 0.5 N·m (71 oz-in)

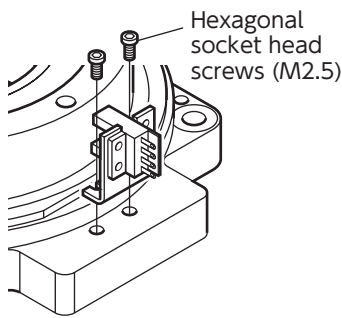

Note Do not use the screw holes (M2.5) for the home sensor of the gearhead for any other purpose.

- Connect the flexible cable with connector to the sensor.

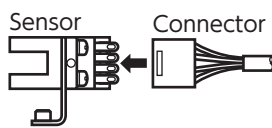

Note

- Do not connect or remove the flexible cable with connector while the power is being supplied. Doing so may cause damage to the sensor.
- Wire the flexible cable in such a way that it will not contact the gearhead.

memo When removing the flexible cable with connector, pull out the connector while pressing it firmly from the top and bottom.

- Secure the shielded plate using the included hexagonal socket head screws (M2.5×2).
Tightening torque: 0.5 N·m (71 oz-in)

Secure the shielded plate to the output table.

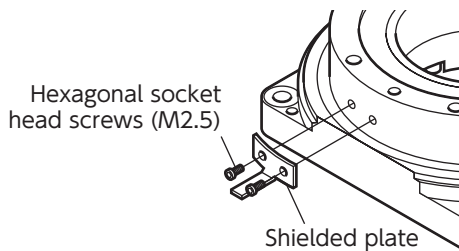

memo

- The photomicrosensor is designed for use inside equipment and therefore has no special means of protection against disturbance light. If the gearhead is to be used under an incandescent lamp or in conditions that are subject to disturbances from external light, provide the means to prevent such interference.
- Use the product after checking the sensor is installed securely.
- Place the power cables such as the motor cable or power supply cable as far apart as possible from the sensor cable. If the power cables and sensor cable have to cross, cross them at a right angle.
- To prevent sensor deterioration due to temperature, operate the gearhead under the following conditions.
Ambient operating temperature 0 to +40 °C (+32 to +104 °F), motor surface temperature 80 °C (176 °F) or lower
- Adhesion of dust on the sensor may cause gearhead malfunction. Clean and/or replace the sensor regularly.
- Use a common GND for the sensor power and user's controller power. Any difference in GND potential will result in a sensor malfunction.

10 Maintenance

10-1 Inspection

This chapter explains the maintenance items in order to operate the product safely and efficiently. If an abnormal condition is noted on the product, discontinue any use and contact your nearest Oriental Motor sales office.

■ Inspection interval

If the product is operated eight hours a day, perform maintenance according to the applicable period specified in the table.

Reduce maintenance intervals accordingly if the operating rate is high such as continuous operation for twenty-four hours.

Maintenance timing	Inspection	Cleaning
When operated for the first time	○	—
Six months after initial operation	○	—
Every six months thereafter	○	—
As needed	—	○

■ Inspection item

- Check if any of the screws having installed the product is loose.
- Check if any of the screws having installed a load is loose.
- Check if the connection part between the product and driver is loose.
- Check if an unusual noise or vibration is generated from a bearing part (ball bearings).

■ Cleaning

- Wipe off any dirt and stains using a soft cloth. To remove stubborn stains, wipe the area using a soft cloth moistened with neutral detergent.
- Do not apply compressed air. Dust may enter through gaps.
- Do not use petroleum solvents, since they will damage the coated surface.

10-2 Warranty

Check on the Oriental Motor Website for the product warranty.

10-3 Disposal

Dispose the product correctly in accordance with laws and regulations, or instructions of local governments.

11 Regulations and standards

- **Hazardous substances**

This product does not contain substances that exceed the regulation values in the RoHS Directive.

12 Specifications

12-1 General specifications

■ Environmental conditions

Operating environment	Ambient temperature	0 to +40 °C (+32 to +104 °F) (Non-freezing)
	Ambient humidity	85 % or less (Non-condensing)
	Altitude	Up to 1,000 m (3,300 ft.) above sea level
Storage environment	Ambient temperature	-20 to +60 °C (-4 to +140 °F) (Non-freezing)
Shipping environment	Ambient humidity	85 % or less (Non-condensing)
	Altitude	Up to 3,000 m (10,000 ft.) above sea level
Degree of protection		IP40

13 Accessories

■ Home-sensor set

Home-sensor set model	Applicable product	Sensor output
PADG-SB	DGN130, DGN200	NPN
PADG-SBY		PNP

Note The home-sensor set cannot be used with **DGN85** and **DGN170**.

- Unauthorized reproduction or copying of all or part of this manual is prohibited.
If a new copy is required to replace an original manual that has been damaged or lost, please contact your nearest Oriental Motor sales office.
- Oriental Motor shall not be liable whatsoever for any problems relating to industrial property rights arising from use of any information, circuit, equipment or device provided or referenced in this manual.
- Characteristics, specifications and dimensions are subject to change without notice.
- While we make every effort to offer accurate information in the manual, we welcome your input. Should you find unclear descriptions, errors or omissions, please contact your nearest Oriental Motor sales office.
- **Orientalmotor** is registered trademark or trademark of Oriental Motor Co., Ltd., in Japan and other countries.
Other product names and company names mentioned in this manual may be registered trademarks or trademarks of their respective companies and are hereby acknowledged. The third-party products mentioned in this manual are recommended products, and references to their names shall not be construed as any form of performance guarantee. Oriental Motor is not liable whatsoever for the performance of these third-party products.

© Copyright ORIENTAL MOTOR CO., LTD. 2024

Published in April 2026

- Please contact your nearest Oriental Motor office for further information.

ORIENTAL MOTOR U.S.A. CORP.
Technical Support Tel:800-468-3982
8:30am EST to 5:00pm PST (M-F)

ORIENTAL MOTOR (EUROPA) GmbH
Schiesstraße 44, 40549 Düsseldorf, Germany
Technical Support Tel:00 800/22 55 66 22

ORIENTAL MOTOR (UK) LTD.
Blythe Valley Business Park,
Central Blvd Blythe Valley Park,
Solihull B90 8AG, United Kingdom
Tel:+44-1926-671220

ORIENTAL MOTOR (FRANCE) SARL
Tel:+33-1 47 86 97 50

ORIENTAL MOTOR ITALIA s.r.l.
Tel:+39-02-93906347

ORIENTAL MOTOR ASIA PACIFIC PTE. LTD.
Singapore
Tel:1800-842-0280

ORIENTAL MOTOR (MALAYSIA) SDN. BHD.
Tel:1800-806-161

ORIENTAL MOTOR (THAILAND) CO., LTD.
Tel:1800-888-881

ORIENTAL MOTOR (INDIA) PVT. LTD.
Tel:1800-120-1995 (For English)
1800-121-4149 (For Hindi)

TAIWAN ORIENTAL MOTOR CO., LTD.
Tel:0800-060708

SHANGHAI ORIENTAL MOTOR CO., LTD.
Tel:400-820-6516

INA ORIENTAL MOTOR CO., LTD.
Korea
Tel:080-777-2042

ORIENTAL MOTOR CO., LTD.
4-8-1 Higashiueno, Taito-ku, Tokyo
110-8536 Japan
Tel:+81-3-6744-0361
www.orientalmotor.co.jp/ja