



# **Data Setter OPX-2A**

---

## **OPERATING MANUAL Before Use**

Thank you for purchasing an Oriental Motor product.

This Operating Manual describes product handling procedures and safety precautions.

- Please read it thoroughly to ensure safe operation.
- Always keep the manual where it is readily available.



### Table of contents

1	Safety precautions.....	2
2	Introduction.....	3
3	Preparation.....	5
3.1	Checking the product.....	5
3.2	Names and functions of parts .....	5
3.3	How to read the display .....	6
3.4	How to read the LED indicators .....	6
3.5	Types of modes .....	7
3.6	Edit lock function.....	7
3.7	Basic operations of the <b>OPX-2A</b> .....	8
3.8	Rewriting the data.....	9
4	Installation and connection of the <b>OPX-2A</b> .....	10
4.1	Location for installation .....	10
4.2	Installation method.....	10
4.3	Connection method.....	11

# 1 Safety precautions

The precautions described below are intended to prevent danger or injury to the user and other personnel through safe, correct use of the product. Use the product only after carefully reading and fully understanding these instructions.

Also read the “Safety precautions” sections in the operating manuals that came with the product you are combining with the **OPX-2A**.

 <b>Warning</b>	Handling the product without observing the instructions that accompany a “Warning” symbol may result in serious injury or death.
 <b>Caution</b>	Handling the product without observing the instructions that accompany a “Caution” symbol may result in injury or property damage.
<b>Note</b>	The items under this heading contain important handling instructions that the user should observe to ensure safe use of the product.

 **Warning**

## General

- Do not use the product in explosive or corrosive environments, in the presence of flammable gases, locations subjected to splashing water, or near combustibles. Doing so may result in fire, electric shock or injury.
- Assign qualified personnel the task of installing, wiring, operating/controlling, inspecting and troubleshooting the product. Failure to do so may result in fire, electric shock or injury.
- When the applicable product’s protection function is triggered, first remove the cause and then clear the protection function. Continuing the operation without removing the cause of the problem may cause malfunction of the applicable product, leading to injury or damage to equipment.

## Repair, disassembly and modification

- Do not disassemble or modify the data setter. This may cause electric shock or injury. Refer all such internal inspections and repairs to the branch or sales office from which you purchased the product.

 **Caution**

## General

- Do not use the applicable product beyond their specifications, or electric shock, injury or damage to equipment may result.

## Operation

- Provide an emergency stop device or emergency stop circuit external to the equipment so that the entire equipment will operate safely in the event of a system failure or malfunction. Failure to do so may result in injury.

## Disposal

- To dispose of the data setter, disassemble it into parts and components as much as possible and dispose of individual parts/components as industrial waste.

## 2 Introduction

Only qualified personnel should work with the product.

Use the product correctly after thoroughly reading the section “1 Safety precautions” on p.2.

The product described in this manual has been designed and manufactured for use in general industrial machinery, and must not be used for any other purpose. Oriental Motor Co., Ltd. is not responsible for any damage caused through failure to observe this warning.

### ■ Structure of the manual

The **OPX-2A** comes with the manuals specified below.

- OPERATING MANUAL Before Use (this document)

Names and functions of parts of the **OPX-2A**, how to read the display area, overview of basic operations, and installation and connection, are explained, among others.

- OPERATING MANUAL for each applicable product

The screen transitions and setting items are explained, among others, for each product used in combination with the **OPX-2A**.

### ■ Overview of the product

The **OPX-2A** is a data setter that lets you set operating data and parameters, perform monitoring, etc.

So that the **OPX-2A** is used correctly and safely, thoroughly read the operating manual that came with product you are using and understand the basic operating procedures and other details of the applicable product.

**Note** | The setting items and screen transitions vary depending on the product used in combination with the **OPX-2A**.

### ■ Features of the OPX-2A

The **OPX-2A** can be used not only to set applicable product operating data and parameters, but it also serves as a storage location for applicable product data. Applicable product data is saved in the areas called “data banks”. Four data banks are provided.

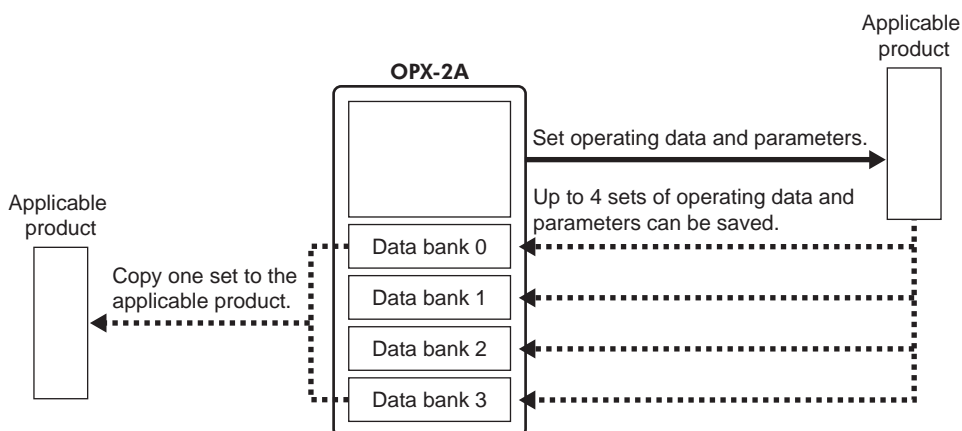

## ■ Specifications

Connection	Mini DIN, 8 pins
External dimensions	96 (W)×72 (H)×21.5 (D) mm [3.78 (W)×2.83 (H)×0.85 (D) in.]
Cable length	5 m (16.4 ft.)
Mass	0.25 kg (8.8 oz)

## ■ Applicable product

Refer to “Information” (HM-40108) for the products that can be used in combination with the **OPX-2A**. These products are referred to as an “applicable product” in this document.

## ■ Hazardous substances

RoHS (Directive 2002/95/EC 27Jan.2003) compliant

## 3 Preparation

This chapter explains the items you should know before using the **OPX-2A**.

### 3.1 Checking the product



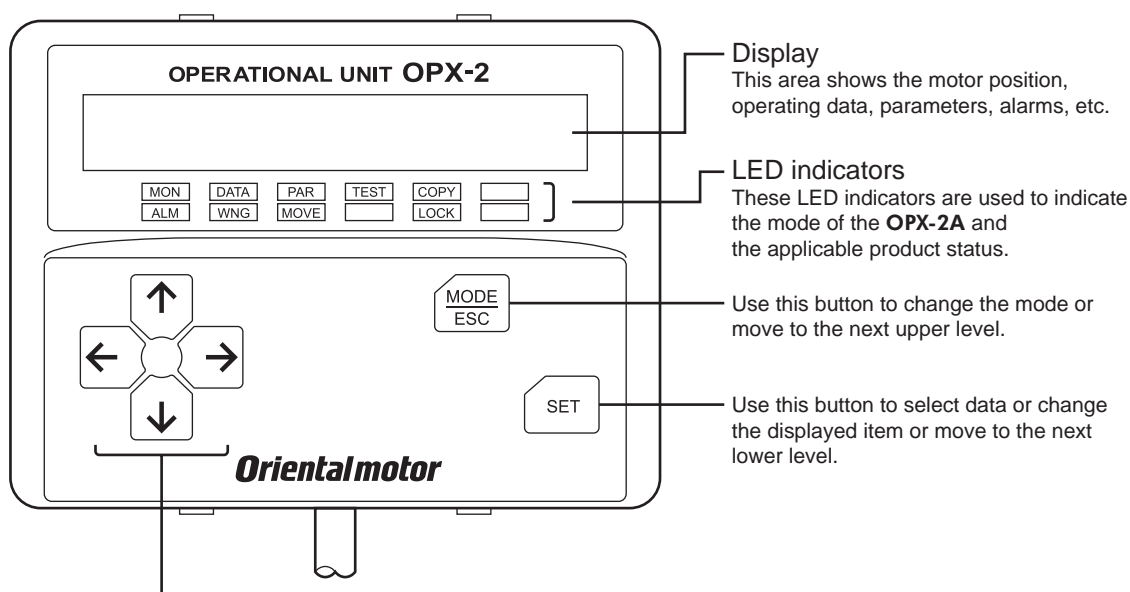

Verify that the items listed below are included. Report any missing or damaged items to the branch or sales office from which you purchased the product.

- **OPX-2A** ..... 1 unit
- OPERATING MANUAL (CD-ROM) ..... 1 pc.
- Information ..... 1 copy

### 3.2 Names and functions of parts



Use these buttons to change the selected item or set operating data and parameters.

- 
 Use these buttons to increase or decrease the value or change the selected item
- 
 Use these buttons to navigate through each data or parameter to a desired digit.

#### ■ Notation

In this manual, keys are denoted by symbols, such as  $\left[ \begin{smallmatrix} \text{MODE} \\ \text{ESC} \end{smallmatrix} \right]$   $[\text{SET}]$   $[\uparrow]$   $[\downarrow]$   $[\leftarrow]$   $[\rightarrow]$ .  
 In figures, a simplified illustration of the display and LED indicators is used, as shown below.



### 3.3 How to read the display

The display consists of 7-segment LEDs. (The number “5” and alphabet “S” are the same.)

• Numbers

1	1	2	2	3	3	4	4	5	5	6	6	7	7	8	8	9	9	0	0
---	---	---	---	---	---	---	---	---	---	---	---	---	---	---	---	---	---	---	---

• Alphabet

A	A	B	b	C	c	D	d	E	E	F	F	G	G	H	H	I	i	J	J
K	K	L	L	M	m	N	n	O	O	P	P	Q	Q	R	r	S	S	T	T
U	U	V	v	W	W	Y	Y												

• Signs

+	+	-	-
---	---	---	---

### 3.4 How to read the LED indicators

When the operation mode is changed or an alarm or warning generates, a corresponding LED will be lit. While the motor is operating or the edit lock function is enabled, the condition is also indicated by the illumination of a corresponding LED.

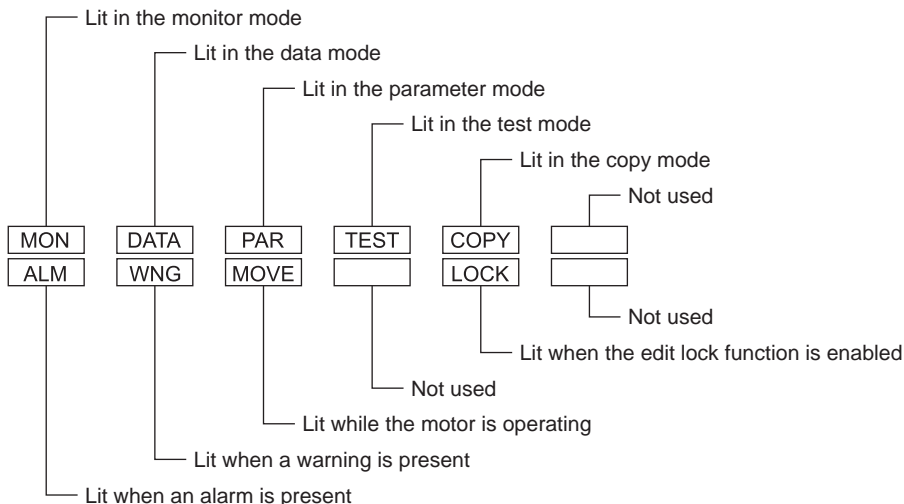

## 3.5 Types of modes

The **OPX-2A** has multiple modes. The mode will change every time the  $\left[ \begin{smallmatrix} \text{MODE} \\ \text{ESC} \end{smallmatrix} \right]$  key is pressed. The display starts in the monitor mode when the power is turned on. Modes that can be selected vary depending on the applicable product.

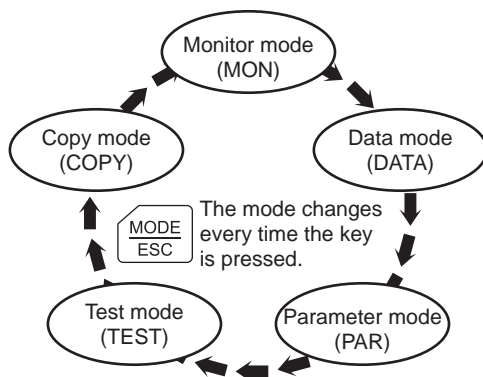

When the mode is changed, the LED indicator corresponding to the previous mode will turn off and the one corresponding to the new mode will be lit.

Identify the current operation mode based on the LED indicator currently lit.

## 3.6 Edit lock function

Enable the edit lock function if you want to prevent operating data and parameters from being edited or cleared.

Parameters cannot be changed or deleted while the edit lock function is enabled.

- **Setting the edit lock function**

In the top screen of each mode, press the  $\left[ \begin{smallmatrix} \text{MODE} \\ \text{ESC} \end{smallmatrix} \right]$  key for at least 5 seconds.

The display will show “LoCK” and the edit lock function will be enabled.

The “LOCK” LED in the LED indicator area will also be lit.

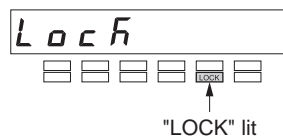

- **Canceling the edit lock function**

Again in the top screen of each operation mode, press the  $\left[ \begin{smallmatrix} \text{MODE} \\ \text{ESC} \end{smallmatrix} \right]$  key for at least 5 seconds.

The display will show “UnLoCK” and the edit lock function will be cancelled.

The “LOCK” LED in the LED indicator area will turn off.

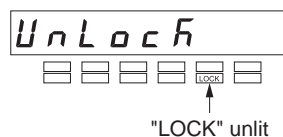

### 3.7 Basic operations of the OPX-2A

Use the six keys  $\left[ \begin{smallmatrix} \text{MODE} \\ \text{ESC} \end{smallmatrix} \right]$   $\left[ \text{SET} \right]$   $\left[ \uparrow \right]$   $\left[ \downarrow \right]$   $\left[ \leftarrow \right]$   $\left[ \rightarrow \right]$  to set data and operate the motor.

#### ■ Operation flow

The **OPX-2A** is operated according to the flow shown below.

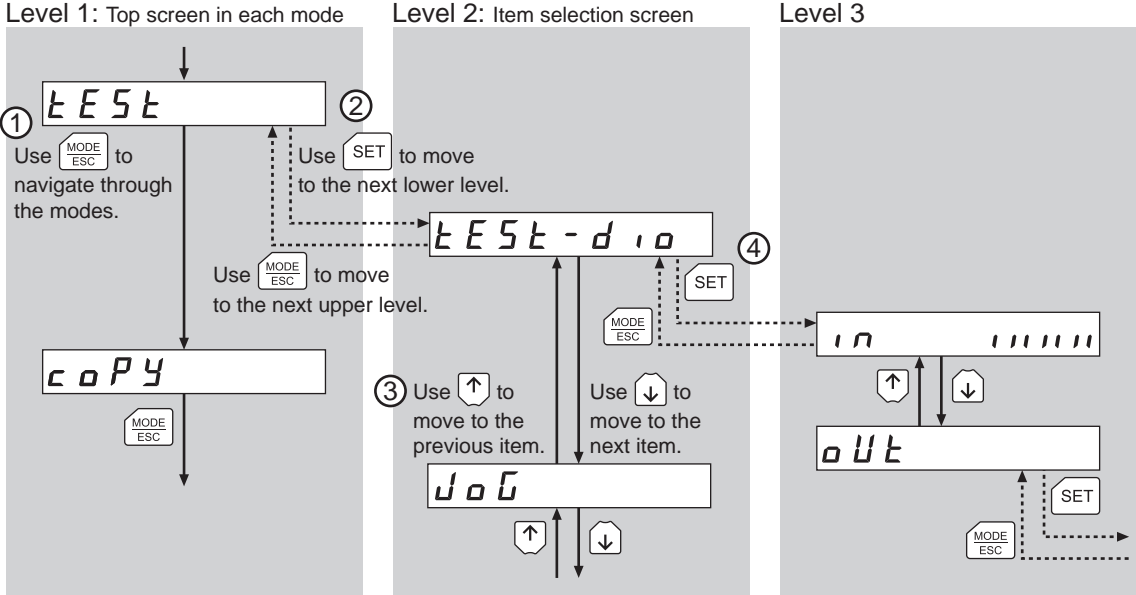

- ① Use the  $\left[ \begin{smallmatrix} \text{MODE} \\ \text{ESC} \end{smallmatrix} \right]$  key to select a desired mode appropriate for your intended operation.  
Example: If you want to use a function in the test mode, press the  $\left[ \begin{smallmatrix} \text{MODE} \\ \text{ESC} \end{smallmatrix} \right]$  key to select the test mode (indicated by a lit “TEST” LED). The top screen of the test mode is displayed.
- ② Press the  $\left[ \text{SET} \right]$  key to move to the next lower level.
- ③ Use the  $\left[ \uparrow \right]$   $\left[ \downarrow \right]$  keys to select a desired item.
- ④ To move to the next lower level, press the  $\left[ \text{SET} \right]$  key.  
To return to the previous level, press the  $\left[ \begin{smallmatrix} \text{MODE} \\ \text{ESC} \end{smallmatrix} \right]$  key.

As explained above, use the  $\left[ \text{SET} \right]$  key to navigate through the levels and use the  $\left[ \uparrow \right]$   $\left[ \downarrow \right]$  keys to select a desired item. This is the basic operation flow.

**Note** If the  $\left[ \text{SET} \right]$  key on the **OPX-2A** is pressed while internal processing is being performed, the top screen will not change to any of its sub-screens and “mEm-bUSY” will be shown on the display. Be sure to wait until all internal processing is completed, before pressing the  $\left[ \text{SET} \right]$  key.



## ■ How to input values

As an example, how to change “+30” to “-100” is explained.

### Basic operations

- Use the [↑] [↓] keys to increase/decrease the value or change the sign.  
Use the [←] [→] keys to move to the digit you want to edit.
- If positive and negative values are differentiated, each value is preceded by a sign.
- You can edit the digit currently blinking.

1. First, change the 10's place from “3” to “0.”  
Press the [←] key once to move to the 10's digit you want to edit.
2. Press the [↓] key three times to change the value to “0.”
3. Next, change the 100's place from “0” to “1.”  
Press the [←] key once to move to the 100's digit you want to edit.
4. Press the [↑] key to change the value to “1.”
5. Next, change the sign.  
Press the [←] key once to move to the sign digit you want to edit.
6. Press the [↑] or [↓] key once to change the sign to “-.”
7. After all digits have been changed, press the [SET] key to confirm the value.  
All digits comprising the value blink for approx. 2 seconds.

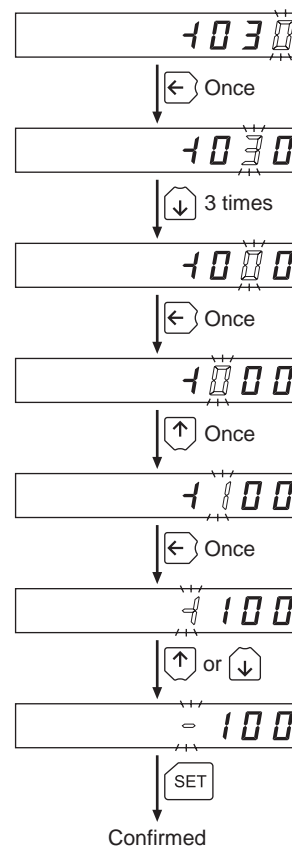

### Note

If the value you have input is outside the setting range, “Error” will be displayed for 1 second. If this error display appears, input a different value that falls within the allowable setting range.

## 3.8 Rewriting the data

Operating data and parameters saved in the memory of the applicable product can be rewritten up to approx. 100,000 times.

The saved data is rewritten when certain operations, such as those listed below, are performed (the specific operations vary depending on the applicable product):

- Change any operating data or parameter
- Download data from the **OPX-2A** to the applicable product
- Initialize operating data and parameters
- Preset the current position
- Preset Z-phase
- Offset the analog speed input
- Offset the analog torque input

# 4 Installation and connection of the OPX-2A

## 4.1 Location for installation

The **OPX-2A** is designed and manufactured for installation in equipment.

Install it in a well-ventilated location that provides easy access for inspection. The location must also satisfy the following conditions:

- Inside an enclosure that is installed indoors (provide vent holes)
- Operating ambient temperature 0 to +40 °C (+32 to +104 °F) (non-freezing)
- Operating ambient humidity 85% or less (no condensation)
- Area that is free of explosive atmosphere or toxic gas (such as sulfuric gas) or liquid
- Area not exposed to direct sun
- Area free of excessive amount of dust, iron particles or the like
- Area not subject to splashing water (rain, water droplets), oil (oil droplets) or other liquids
- Area free of excessive salt
- Area not subject to continuous vibration or excessive shocks
- Area free of excessive electromagnetic noise (from welders, power machinery, etc.)
- Area free of radioactive materials, magnetic fields or vacuum
- 1000 m (3300 ft.) or less above sea level

## 4.2 Installation method

Using a metal plate of 1 to 3 mm (0.04 to 0.12 in.) in thickness, insert the **OPX-2A** into the mounting hole from the front side and securely affix the **OPX-2A**.

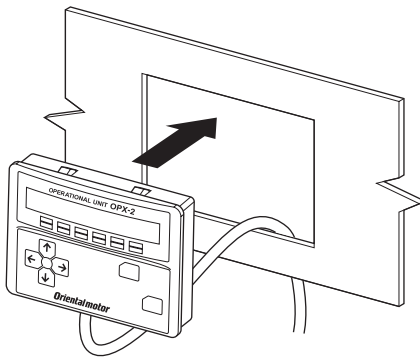

- Dimension of mounting hole [mm (in.)]

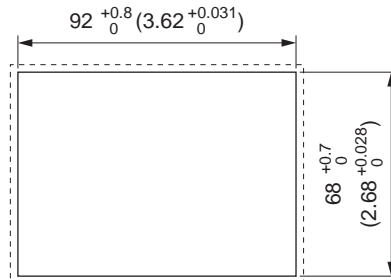

### Removing method

Press all of the four hooks provided on top and bottom of the **OPX-2A**. In this condition, press the **OPX-2A** forward to release.

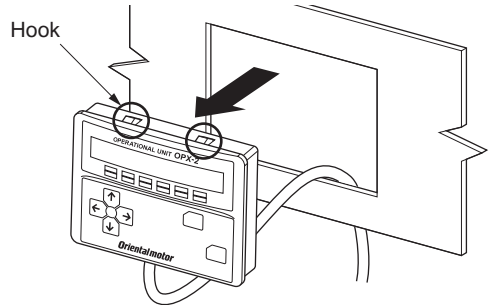

## 4.3 Connection method

Plug the connector attached to the end of the **OPX-2A** cable into the communication connector on the applicable product, and then turn on the power to the applicable product.

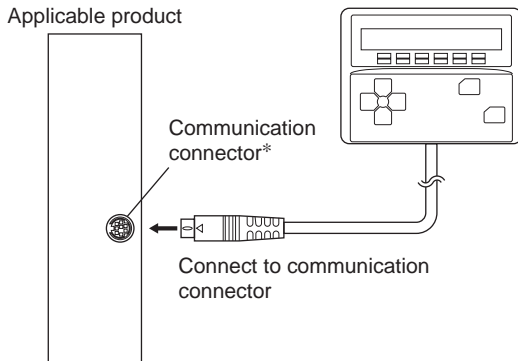

\* The position of the communication connector varies depending on the applicable product.

#### Note

- When operating data and parameters are set on the **OPX-2A**, they will be stored in the applicable product. Once stored in the applicable product, the data will not be cleared even after the **OPX-2A** is disconnected from the applicable product.
- Turning on the power to the applicable product will also turn on the power to the **OPX-2A**. Turning off the applicable product power will turn off the **OPX-2A** power.
- Turn off the applicable product power before connecting or disconnecting the **OPX-2A** cable. If 24 VDC power is being supplied, also turn off the 24 VDC power supply.

Have you installed and connected your data setter **OPX-2A** correctly?

The specific setting items and screen transitions vary depending on the product used. Refer to the **OPX-2A** operating manual for each applicable product you are combining with your **OPX-2A**, and follow the instructions.

- Unauthorized reproduction or copying of all or part of this manual is prohibited.  
If a new copy is required to replace an original manual that has been damaged or lost, please contact your nearest Oriental Motor branch or sales office.
- Oriental Motor shall not be liable whatsoever for any problems relating to industrial property rights arising from use of any information, circuit, equipment or device provided or referenced in this manual.
- Characteristics, specifications and dimensions are subject to change without notice.
- While we make every effort to offer accurate information in the manual, we welcome your input. Should you find unclear descriptions, errors or omissions, please contact the nearest office.
- **Orientalmotor** is a registered trademark or trademark of Oriental Motor Co., Ltd., in Japan and other countries. Other product names and company names mentioned in this manual may be registered trademarks or trademarks of their respective companies and are hereby acknowledged. The third-party products mentioned in this manual are recommended products, and references to their names shall not be construed as any form of performance guarantee. Oriental Motor is not liable whatsoever for the performance of these third-party products.

© Copyright ORIENTAL MOTOR CO., LTD. 2009

- Please contact your nearest Oriental Motor office for further information.

ORIENTAL MOTOR U.S.A. CORP.  
 Technical Support Tel:(800)468-3982  
 8:30 A.M. to 5:00 P.M., P.S.T. (M-F)  
 7:30 A.M. to 5:00 P.M., C.S.T. (M-F)  
 E-mail: techsupport@orientalmotor.com  
 www.orientalmotor.com

ORIENTAL MOTOR (EUROPA) GmbH  
 Headquarters and Düsseldorf Office  
 Tel:0211-52067-00 Fax:0211-52067-099  
 Munich Office  
 Tel:089-3181225-00 Fax:089-3181225-25  
 Hamburg Office  
 Tel:040-76910443 Fax:040-76910445

ORIENTAL MOTOR (UK) LTD.  
 Tel:01256-347090 Fax:01256-347099

ORIENTAL MOTOR (FRANCE) SARL  
 Tel:01 47 86 97 50 Fax:01 47 82 45 16

ORIENTAL MOTOR ITALIA s.r.l.  
 Tel:02-93906346 Fax:02-93906348

TAIWAN ORIENTAL MOTOR CO.,LTD.  
 Tel:(02)8228-0707 Fax:(02)8228-0708

SINGAPORE ORIENTAL MOTOR PTE LTD  
 Tel:(6745)7344 Fax:(6745)9405

ORIENTAL MOTOR (MALAYSIA) SDN. BHD.  
 Tel:(03)22875778 Fax:(03)22875528

ORIENTAL MOTOR (THAILAND) CO.,LTD.  
 Tel:66-2-254-6113 Fax:66-2-254-6114

INA ORIENTAL MOTOR CO.,LTD.  
 KOREA  
 Tel:(032)822-2042~3 Fax:(032)819-8745

ORIENTAL MOTOR CO.,LTD.  
 Headquarters Tokyo, Japan  
 Tel:(03)3835-0684 Fax:(03)3835-1890