



Brushless DC motor and Driver

# AXH Series

# OPERATING MANUAL



## Table of contents

Introduction .....	Page 2
Safety precautions .....	Page 3
Preparation .....	Page 6
Checking the product .....	Page 6
Names and functions of parts .....	Page 8
Installation .....	Page 9
Installation site .....	Page 9
Installation of motor (gearhead) .....	Page 9
Load installation .....	Page 11
Driver installation .....	Page 12
Installing and wiring in compliance with EMC directive .....	Page 14
Connection .....	Page 18
Motor connection .....	Page 18
Power connection .....	Page 19
Connection of input signal and output signal .....	Page 20
Example connection .....	Page 21
Input signals and output signals .....	Page 22
Setting the running speed .....	Page 27
Inspection .....	Page 29
Trouble diagnosis and countermeasures ...	Page 30

Thank you for purchasing an Oriental Motor product.

This Operating Manual describes product handling procedures and safety precautions.

- Please read it thoroughly to ensure safe operation.
- Always keep the manual where it is readily available.

---

# Introduction

The **AXH** series is a brushless DC motor adopting a thin, high torque motor and a 24 VDC input open case type high-precision driven. The product is available in three types; a round shaft type which is the optimum for high speed requirements and a combination type\* equipped with a special-purpose gearhead which is best suited to high-torque operation by gear speed reduction (a pinion shaft type\* compatible with optional special-purpose gearhead).

\*The motor with a frame size of 42 mm (1.65 in.) is a geared type. There is no pinion shaft type available.

This product is designed to be incorporated into general industrial machinery, and must not be used for other purposes. For the power supply use a DC power supply with reinforced insulation on its primary and secondary sides. It should be noted that we are not responsible for any damages caused by ignoring this warning.

If correspondence between the European low voltage directive and EMC directive is required, take the following steps:

## ■For Low Voltage Directive

- Since this product is based on 24 VDC power input, it is outside the application scope of low voltage directives.
- When applying the equipment incorporating this product to the low voltage directive, connect the driver power input to the DC power source where the primary and secondary sides are provided with reinforced insulation.
- Install this product in the equipment built-in type enclosure.
- Enclosure classification  
Driver: IP00  
Motor: IP65 (Lead wire type: IP40)

## ■For EMC Directive

This product has received EMC measures under the conditions specified in “Example of motor and driver installation and wiring” on page 17.

Be sure to conduct EMC measures with the product assembled in your equipment by referring to “Installing and wiring in compliance with EMC directive” on page 14.

## ■Applicable Standards

	Applicable Standards	Certification Body	Standards File No.
<b>AXH015</b> type <b>AXH230</b> type <b>AXH450</b> type	Motor: UL 1950 CSA C22.2 No.950 Driver: UL 60950 CSA C22.2 No.60950	UL	E208200
<b>AXH5100</b> type	UL 1950 CSA C22.2 No.950	UL	E208200

- The names of products certified to conform with relevant standards are represented by applicable unit model motor and driver part numbers.
- A Heating Test, an Over-Load Test and a Locked-Rotor Test has been conducted with a aluminum radiation plate of size indicated the table below (except for **AXH015K-A**). For the motor with a gearhead, tests has been conducted with a gearhead instead of the radiation plate.

[Unit: mm (inch)]

Unit model	Size	Thickness	Material
<b>AXH230KC-A</b>	115 × 115 (4.53 × 4.53)	5 (0.197)	Aluminum
<b>AXH450KC-A</b>	135 × 135 (5.31 × 5.31)		
<b>AXH5100KC-A</b>	200 × 200 (7.87 × 7.87)		

#### Installation conditions

- The product is to be used as a component within other equipment.
- Overvoltage category: Category I
- Pollution degree: 2
- Protection against electric shock: Class III equipment

## Safety precautions

Only qualified personnel should work with the product.

Use the product correctly after thoroughly reading the section “Safety precautions”.

The precautions described below are intended to prevent danger or injury to the user and other personnel through safe, correct use of the product. Use the product only after carefully reading and fully understanding these instructions.

### **Warning**

Handling the product without observing the instructions that accompany a “Warning” symbol may result in serious injury or death.

### **Caution**

Handling the product without observing the instructions that accompany a “Caution” symbol may result in injury or property damage.

### **Note**

The items under this heading contain important handling instructions that the user should observe to ensure safe use of the product.

---

## **Warning**

### **General**

- Do not use the product in explosive or corrosive environments, in the presence of flammable gases, locations subjected to splashing water, or near combustibles. Doing so may result in fire or injury.
- Assign qualified personnel the task of installing, wiring, operating/controlling, inspecting and troubleshooting the product. Failure to do so may result in fire or injury.
- When the driver's protection function is triggered, first remove the cause and then clear the protection function. Continuing the operation without determining the cause of the problem may cause malfunction of the motor, leading to injury or damage to equipment.

### **Installation**

- Install the motor (gearhead) and driver in their enclosures in order to prevent injury.

### **Connection**

- Keep the driver's input-power voltage within the specified range to avoid fire.
- Connect the cables securely according to the wiring example in order to prevent fire.
- Do not forcibly bend, pull or pinch the cable. Doing so may fire.
- For the driver's power supply use a DC power supply with reinforced insulation on its primary and secondary sides. Failure to do so may result in electric shock.

### **Operation**

- Turn off the driver power in the event of a power failure, or the motor will suddenly start when the power is restored and may cause injury or damage to equipment.
- Do not use it in a vertical applications. When the driver protection function is triggered, the motor will stop operating. The moving parts fall and may cause injury or damage to equipment.

### **Repair, disassembly and modification**

- Do not disassemble or modify the motor, gearhead or driver. This may cause injury. Refer all such internal inspections and repairs to the branch or sales office from which you purchased the product.

---

## Caution

### General

- Do not use the motor, gearhead and driver beyond their specifications, or injury or damage to equipment may result.
- Do not touch the motor or driver during operation or immediately after stopping. The surfaces are hot and may cause a burn.

### Transportation

- Do not hold the motor (gearhead) output shaft or motor cable. This may cause injury.

### Installation

- Keep the area around the motor and driver free of combustible materials in order to prevent fire or a burn.
- To prevent the risk of damage to equipment, leave nothing around the motor and driver that would obstruct ventilation.
- Provide a cover over the rotating parts (output shaft) of the motor (gearhead) to prevent injury.

### Operation

- Use a motor and driver only in the specified combination. An incorrect combination may cause a fire.
- Provide an emergency-stop device or emergency-stop circuit external to the equipment so that the entire equipment will operate safely in the event of a system failure or malfunction. Failure to do so may result in injury.
- Immediately when trouble has occurred, stop running and turn off the driver power. Failure to do so may result in fire, electric shock or injury.
- To prevent bodily injury, do not touch the rotating parts (output shaft) of the motor during operation.
- Release all driver input signals before turning on the power to the driver. Otherwise, the motor may start suddenly and cause injury or damage to equipment.
- Before moving the motor directly with the hands (as in the case of manual positioning), confirm that the driver operation input is “OFF” to prevent injury.
- Do not perform the motor’s starting and stopping operations by turning the power on and off. Perform them by inputting START/STOP and RUN/BRAKE. This may cause injury or damage to the equipment.
- The motor’s surface temperature may exceed 70°C, even under normal operating conditions. If a motor is accessible during operation, post a warning label shown in the figure in a conspicuous position to prevent the risk of burns.



Warning label

### Disposal

- To dispose of the motor, gearhead or driver, disassemble it into parts and components as much as possible and dispose of individual parts/components as industrial waste.

---

# Preparation

The following describes the items to be confirmed, names and functions of individual components.

## Checking the product

Open the package and make sure that the following items are supplied.

If there is any shortage or damage, contact the sales office where you bought the product.

The unit model of the product you bought should be checked by reference to the model on the label of the package.

Check the models of the gearhead, motor and driver by reference to the models on the name plate of each product.

The table on page 7 shows the combination of the gearhead, motor and driver according to unit models.

### ■ Round shaft type, Pinion shaft type, Geared type

- One motor
- One driver
- One input/output signal cable [300 mm (11.8 in.)]
- One power cable [300 mm (11.8 in.)]
- Manual

### ■ Combination type

- One motor with gearhead
- One key
- One driver
- One input/output signal cable [300 mm (11.8 in.)]
- One power cable [300 mm (11.8 in.)]
- One set of hexagon socket head bolts (four each of bolts, plain washers and nuts)
- Manual

Combinations of gearheads, motors and drivers

Type	Unit model*	Gearhead model	Motor model*	Driver model
Round shaft type	<b>AXH015K-A</b>	——	AXHM015K-A	AXHD15K
	<b>AXH230KC-A</b>	——	AXHM230KC-A	AXHD30K
	<b>AXH450KC-A</b>	——	AXHM450KC-A	AXHD50K
	<b>AXH5100KC-A</b>	——	AXHM5100KC-A	AXHD100K
Pinion shaft type	<b>AXH230KC-GFH</b>	——	AXHM230KC-GFH	AXHD30K
	<b>AXH450KC-GFH</b>	——	AXHM450KC-GFH	AXHD50K
	<b>AXH5100KC-GFH</b>	——	AXHM5100KC-GFH	AXHD100K
Geared type	<b>AXH015K-□</b>	——	AXHM015K-□	AXHD15K
Combination type	<b>AXH230KC-□</b>	<b>GFH2G□</b>	AXHM230KC-GFH	AXHD30K
	<b>AXH450KC-□</b>	<b>GFH4G□</b>	AXHM450KC-GFH	AXHD50K
	<b>AXH5100KC-□</b>	<b>GFH5G□</b>	AXHM5100KC-GFH	AXHD100K

The box (□) of the model will be filled with the numeral to represent the gear reduction ratio.

\* For the lead wire type, "KC" of the unit model and motor model are replaced by "K" (except for **AXH015** type).

## Names and function of parts

The following describes the names and functions of individual components of the driver. For detailed information of each unit, see the page shown in the square bracket.

Driver model: AXHD15K, AXHD30K, AXHD50K

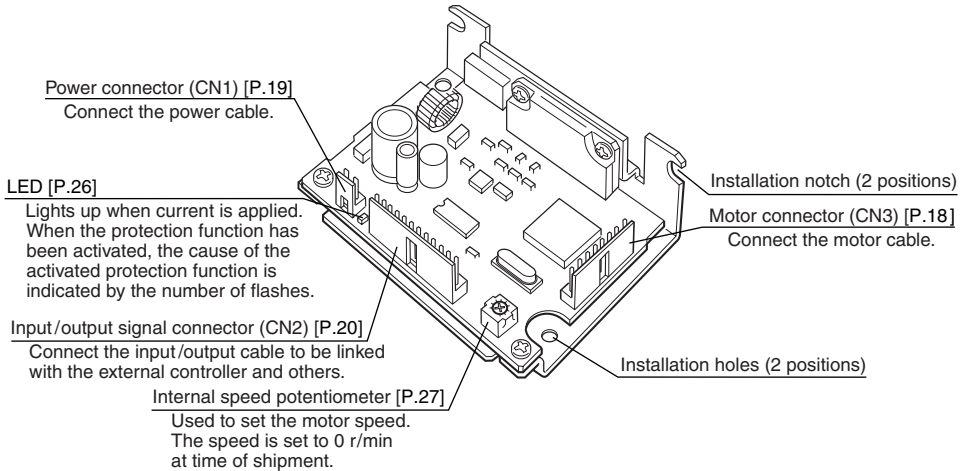

Driver model: AXHD100K

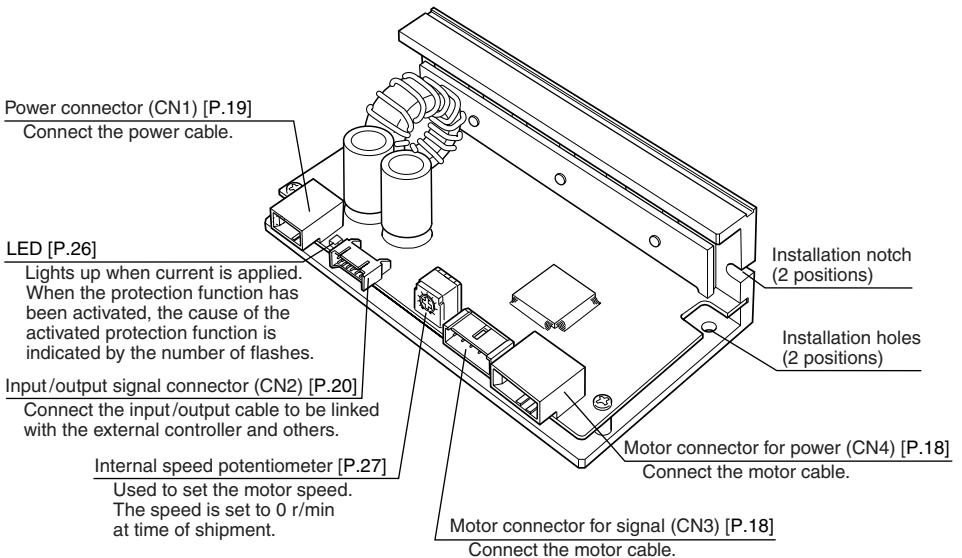



---

# Installation

The following shows the motor (gearhead) and driver installation environment, installation method and load installation.

## Installation site

The motor (gearhead) and driver are designed and manufactured to be incorporated into the equipment.

To ensure effective ventilation and easy inspection, install it in the following site.

- Inside an enclosure that is installed indoors (provide vent holes)
- Operating ambient temperature Motor: 0°C to +50°C (+32°F to +122°F) [non-freezing]  
Driver: 0°C to +50°C (+32°F to +122°F) [non-freezing]
- Operating ambient humidity 85%, maximum (no condensation)
- Area that is free of explosive atmosphere or toxic gas (such as sulfuric gas) or liquid
- Area not exposed to direct sun
- Area free of excessive amount of dust, iron particles or the like
- Area not subject to splashing water (rains, water droplets), oil (oil droplets) or other liquids
- Area free of excessive salt
- Area not subject to continuous vibration or excessive shocks
- Area free of excessive electromagnetic noise (from welders, power machinery, etc.)
- Area free of radioactive materials, magnetic fields or vacuum

## Installation of motor (gearhead)

### ■ Direction of installation

The motor (gearhead) can be installed in any direction.

### ■ Method of installation

Incorrect installation will deteriorate the performance of the motor (gearhead) and equipment, and may endanger operator safety.

Install the motor (gearhead) on a flat metallic plate having an excellent resistance to vibration and heat conduction. Optional motor mounting brackets are available (sold separately).

### Note

The mounting pilot located on the motor installation surface should be inserted into a countersunk or drilled through hole.

The boss on the gearhead installation surface should be inserted into a countersunk or drilled through hole.

### ◆Round shaft type

To install the motor, use the four installation holes and mount the motor with four bolts (not provided) so that there is no gap with the metallic plate.

Refer to the gearhead instruction manual for mounting the pinion shaft type.

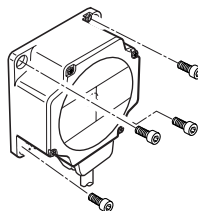

### Note

Install the round shaft type (except for **AXH015K-A**) on the metallic plate of the following dimensions so that the motor casing temperature does not exceed below 90°C (194°F).

**AXH230KC-A** 115 mm × 115 mm (4.53 in. × 4.53 in.)

**AXH450KC-A** 135 mm × 135 mm (5.31 in. × 5.31 in.)

**AXH5100KC-A** 200 mm × 200 mm (7.87 in. × 7.87 in.)

Thickness: 5 mm (0.197 in.)

### ◆Combination type

To install the motor with gearhead, use the four installation holes and mount the motor with four hexagon socket head bolts (provided) so that there is no gap with the metallic plate.

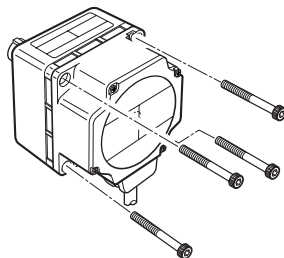

### ◆Geared type

To install the motor, use the four installation holes and mount the motor with four bolts (not provided) so that there is no gap with the metallic plate.

Effective depth of bolt: 8 mm (0.31 in.)

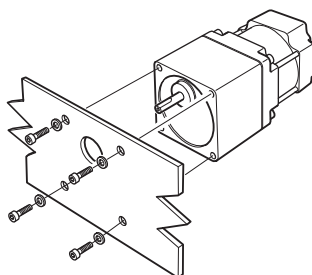

Unit model	Bolt designation	Tightening torque
<b>AXH015K-A</b>	M3	1 N·m (8.85 lb-in)
<b>AXH015K-□, AXH230KC-A, AXH230KC-GFH, AXH230KC-□</b>	M4	1.8 N·m (15.9 lb-in)
<b>AXH450KC-A, AXH450KC-GFH, AXH450KC-□</b>	M6	6.4 N·m (56.6 lb-in)
<b>AXH5100KC-A, AXH5100KC-GFH, AXH5100KC-□</b>	M8	15.5 N·m (137 lb-in)

The box (□) of the unit model will be filled with the numeral to represent the gear reduction ratio.

---

## Load installation

When installing the load to the motor or gearhead, ensure that the motor output shaft or gearhead output shaft and load shaft are aligned with each other. Optional flexible couplings are available (sold separately).

The output shaft of the round shaft type and geared type is provided with a flat. Use double point screws on the flat and provide reliable locking to prevent idle rotation of the load.

The combination type gearhead output shaft is provided with a key groove. A key groove must also be provided on the side of the load to be installed. Use the attached key to lock it in position.

Key dimensions    **AXH230KC-□**: 4 mm (0.1575 in.)  
                          **AXH450KC-□**: 5 mm (0.1969 in.)  
                          **AXH5100KC-□**: 6 mm (0.2362 in.)

### Note

- When connecting the motor (gearhead) with a load, care must be taken to ensure adequate alignment, belt tension and pulley parallelism. The coupling and pulley locking screws must be clamped firmly in position.
- To install a coupling or pulley to the motor output shaft or gear output shaft, sufficient care must be taken not to damage the output shaft and bearing.
- Do not modify or machine the motor (gearhead) output shaft. It may damage the bearing, which may result in motor (gearhead) failure.

### ■ Direct connection of coupling

Ensure that the motor (gearhead) output shaft and load shaft are aligned with each other.

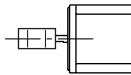

### ■ Belt connection

Ensure that the centerlines of the motor (gearhead) output shaft and load shaft are parallel with each other, and that the line connecting the centers of both pulleys and shaft are at a right angle to each other.

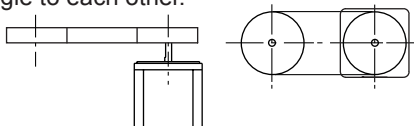

### ■ Gear connection

Provide correct engagement with the center of the gear tooth surface to ensure that the motor (gearhead) output shaft and gear shaft are parallel to each other.

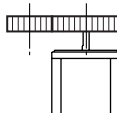

---

## Driver installation

### ■ Direction of installation

The driver is designed on the basis of heat radiation by air convection and heat conduction to the housing.

When installing the driver in the housing, use four installation holes on the driver and install it in the vertical or horizontal direction.

### ■ Method of installation

Install the driver on a flat metallic plate having an excellent resistance to vibration and heat conduction.

Using the driver installation hole or notch, lock the driver with two bolts (M3: not provided) so that there is no gap with the metallic plate.

The driver should be installed 25 mm (1 in.) or more in the horizontal direction away from the housing sides and other equipment inside the housing, and 50 mm (2 in.) or more away from them in the vertical direction.

When two or more drivers are to be installed in parallel, separate them by 20 mm (0.8 in.) or more in the horizontal direction and by 50 mm (2 in.) or more in the vertical direction as illustrated.



### Note

- Do not place any equipment generating much heat or noise around the driver.
- If temperature around the driver is higher than 50°C (122°F), recheck the ventilation conditions and use a fan to provide forced cooling of the driver.



---

## Installing and wiring in compliance with EMC directive

### ■ General

#### ◆ EMC Directive (89/336/EEC, 92/31/EEC)

The **AXH** series has been designed and manufactured for incorporation in general industrial machinery. The EMC directive requires that the equipment incorporating this product comply with these directives.

The installation and wiring method for the motor and driver are the basic methods that would effectively allow the customer's equipment to be compliant with the EMC directive.

The compliance of the final machinery with the EMC directive will depend on such factors as configuration, wiring, layout and risk involved in the control-system equipment and electrical parts. It therefore must be verified through EMC measures by the customer of the machinery.

#### ◆ Applicable Standards

##### EMI

Emission Tests	EN 61000-6-4
Radiated Emission Test	EN 55011

##### EMS

Immunity Tests	EN 61000-6-2
Electrostatic Discharge Immunity Test	IEC 61000-4-2
Radiation Field Immunity Test	IEC 61000-4-3
Fast Transient / Burst Immunity Test	IEC 61000-4-4
Conductive Noise Immunity Test	IEC 61000-4-6
Power Frequency Magnetic Field Immunity Test	IEC 61000-4-8

### ■ Installing and wiring

Effective measures must be taken against the EMI that the **AXH** series may give to adjacent control-system equipment, as well as the EMS of the **AXH** series itself, in order to prevent a serious functional impediment in the machinery.

The use of the following installation and wiring methods will enable the **AXH** series to be compliant with the EMC directive (the aforementioned compliance standards).

#### ◆ About power source

The **AXH** series products are of the DC power-input specification.

Use a DC power supply (such as a switching power supply) that is optimally compliant with the EMC directive.

If a transformer is used in the power supply, be sure to connect a mains filter to the input side of the transformer.

### ◆Connecting mains filter for power source line

Install a mains filter in the AC input line to the DC power supply in order to prevent the noise generated within the driver or control system from propagating outside via the DC power supply.

For mains filters, use FN2330Y-10-06 or FN2310X-10-06 (manufactured by Schaffner EMC), 10ESK1 (by CORCOM), ZAG2210-11S (by TDK Corporation), or an equivalent. Install the mains filter as close to the AC input terminal of the DC power supply as possible, and use cable clamps and other means to secure the input and output cables firmly to the surface of the enclosure. Connect the ground terminal of the mains filter to the grounding point, using as thick and short a wire as possible.

Do not place the AC input cable parallel with the mains-filter output cable. Parallel placement will reduce mains-filter effectiveness if the enclosure's internal noise is directly coupled to the power-supply cable by means of stray capacitance.

### ◆Motor cable connection

When extending the motor cable, use the optional extension cable. The maximum extension distance including the cable length of the motor itself should be 2 m (6.6 ft.).

Option model	Applicable unit type
<b>CC02AXH</b> [1.5 m (4.9 ft.)]	<b>AXH015</b> type, <b>AXH230</b> type, <b>AXH450</b> type
<b>CC02AXH2</b> [1.5 m (4.9 ft.)]	<b>AXH5100</b> type

\* It is also possible to use **FC02HBL** [1.5 m (4.93 ft.)] for the lead wire type of **AXH230** and **AXH450**.

### ◆Ferrite core

Use the ferrite core for extending the motor cable. Ferrite core has the effect of reducing the high frequency noise generated from the control system equipment inside the enclosure.

Use ferrite core 7427122 by Würth Elektronik GmbH & Co. KG, ZCAT3035-1330 by TDK Corporation or its equivalent.

Connect the ferrite cores as close as possible to the driver.

### ◆Wiring the signal cable

Use a braided screen cable of AWG26 (0.14 mm<sup>2</sup>) or more in diameter for the driver signal cable, and keep it as short as possible.

To ground a braided screen cable, use a metal clamp or similar device that will maintain contact with the entire circumference of the braided screen cable. Attach a cable clamp as close to the end of the cable as possible, and connect it to an appropriate grounding point as shown in the figure.

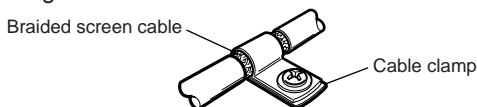

---

### ◆How to ground

The cable used to ground the motor and driver must be as thick and short to the grounding point as possible so that no potential difference is generated. Choose a large, thick and uniformly conductive surface for the grounding point.

#### How to ground the motor

Connect the grounding cable along with a set screw to the grounding point, using an inner-clip washer.

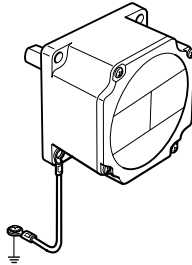

#### How to ground the driver

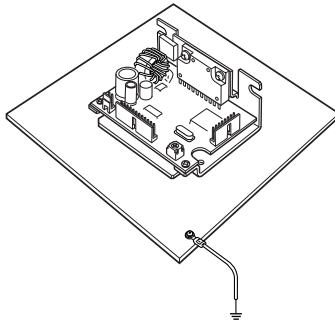

### ◆Others

- Connect the motor and other peripheral control equipment directly to the grounding point so as to prevent a potential difference from developing between grounds.
- When relays or electromagnetic switches are used together with the system, use mains filters and CR circuits to suppress surges generated by them.
- Keep cables as short as possible without coiling and bundling extra lengths.
- Place the power cables such as the motor and power-supply cables as far apart [100 to 200 mm (3.94 to 7.87 in.)] as possible from the signal cables. If they have to cross, cross them at a right angle. Place the AC input cable and output cable of a mains filter separately from each other.



## ◆ Example of motor and driver installation and wiring

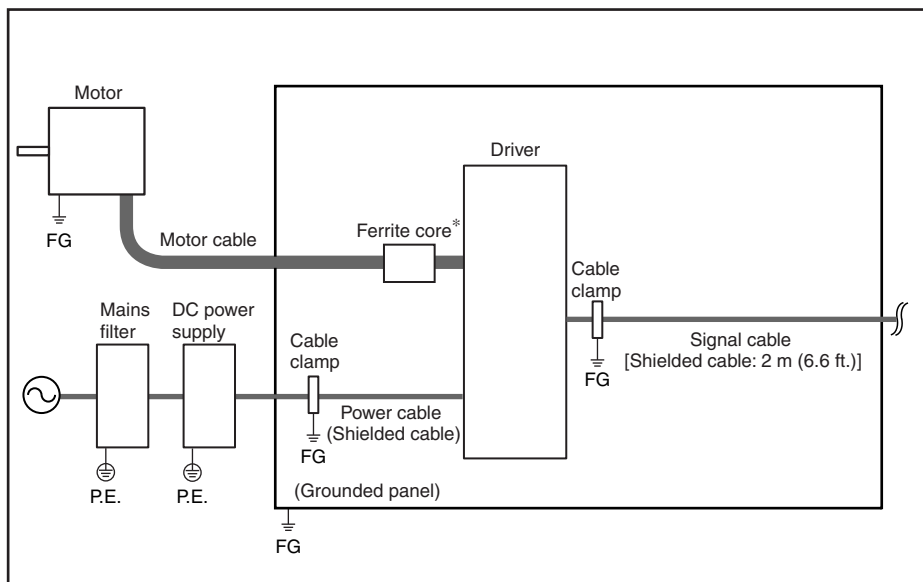

\* Use the ferrite core for extending the motor cable.

## ■ Precautions about static electricity

Static electricity may cause the driver to malfunction or suffer damage. Be careful when handling the driver with the power on. Always use an insulated screwdriver to adjust the driver's internal potentiometer.

## Note

Do not come close to or touch the driver while the power is on.

# Connection

The following shows the method of connecting the driver and motor/power source/ external controller, earth connection method, an example of connection and input/ output signals.

## Motor connection

Insert the motor cable connector into the motor connector (**AXH015/AXH230/AXH450** type: CN3, **AXH5100** type: CN3 and CN4) of the driver.

### Note

- Firmly insert the connector in position. Incomplete connection of the connector may cause operation failure, or may damage the motor or driver.
- Do not push or pull the cable. Handle only the plastic connector instead. Do not apply force in any direction other than that in which the connector is inserted or pulled out. Improper application of force may damage the connector and driver.

When extending the motor cable, use the optional extension cable. The maximum extension distance including the cable length of the motor itself should be 2 m (6.6 ft.).

Option model	Applicable unit type
<b>CC02AXH</b> [1.5 m (4.9 ft.)]	<b>AXH015</b> type, <b>AXH230</b> type, <b>AXH450</b> type
<b>CC02AXH2</b> [1.5 m (4.9 ft.)]	<b>AXH5100</b> type

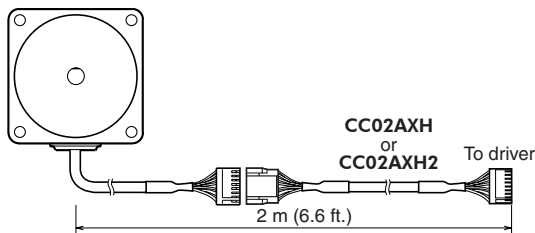

It is also possible to use **FC02HBL** [1.5 m (4.9 ft.)] for the lead wire type of **AXH230** and **AXH450**.

---

## Power connection

Input power voltage is 24 VDC±10%.

Insert the power cable connector into the driver power connector (CN1).

When you do not use the power cable supplied with to the product, use a cable with a diameter equivalent to AWG22 (0.3 mm<sup>2</sup>) or more for **AXH015/AXH230/AXH450** type, and use a AWG18 (0.75 mm<sup>2</sup>) for **AXH5100** type.

Sufficient care must be taken not to mistake the power polarity. Connection with incorrect polarity may damage the driver.

### Note

- Do not route the driver power cable in the same conduit with other power lines or motor cables.
- When you want to turn on the power again or pull out the motor cable connector, do so 5 s or more after power has been turned off.

# Connection of input signal and output signal

## ■ Connection with driver

Insert the connector of the input/output signal cable into the connector of the input/output signal cable (CN2) of the driver.

Color indication represents the color of the attached cable. The connection of CN1 varies, depending on the output signal.

CN1

### AXH015, AXH230, AXH450

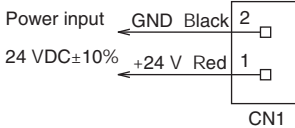

### AXH5100

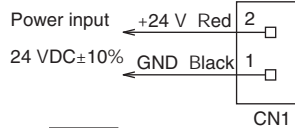

CN2: This connection is common to all output signal.

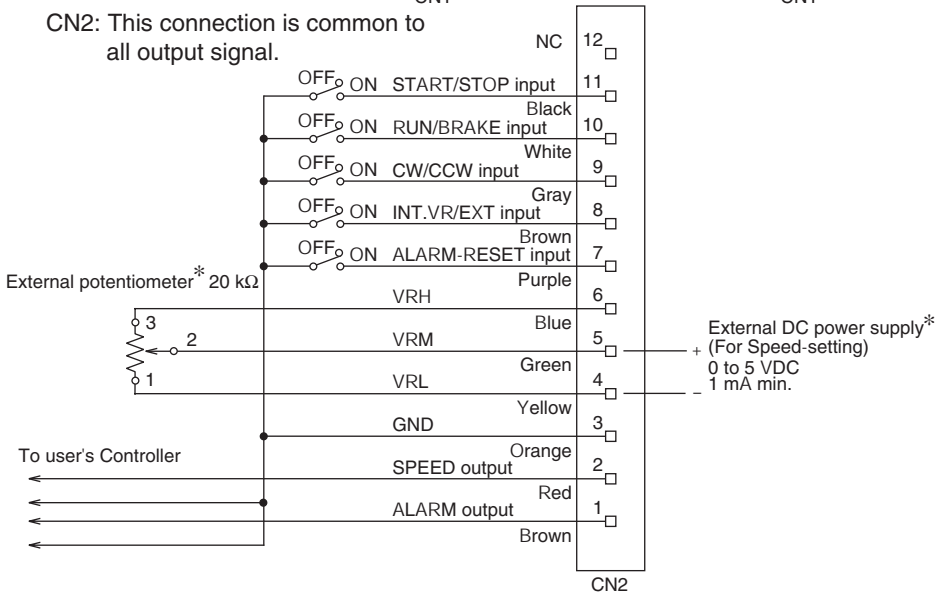

\* Connect either the external potentiometer (option) or DC power supply for the external speed setting.

## Note

- When extending the input/output signal cable, the length must not exceed 2 m (6.6 ft.). To minimize the noise, it should be as short as possible.
- The input/output signal cable must be located 200 mm (7.87 in.) or more away from such inductive loads as electromagnetic relay, and must cross power and motor cables, not parallel to them.
- The cable not used on the terminal opposite to the connector of the input/output signal cable should be provided insulation to ensure that it does not contact other equipment, or should be pulled up to 5 VDC according to the usage of the signal. Or connect it to the signal GND.

# Example connection

## Input signal

### Controller output: 5 V C-MOS

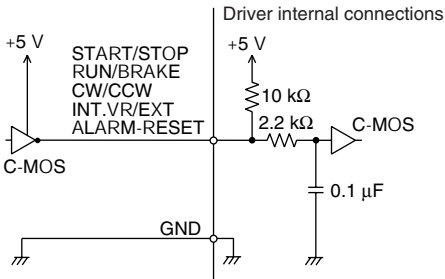

### Controller output: open collector

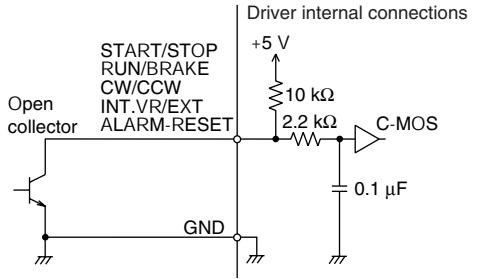

### Switch connection

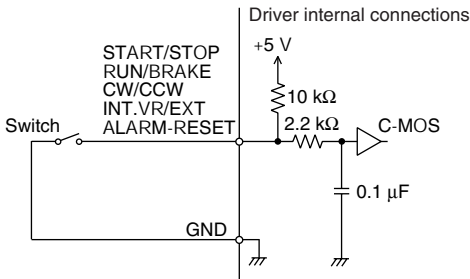

## Output signal

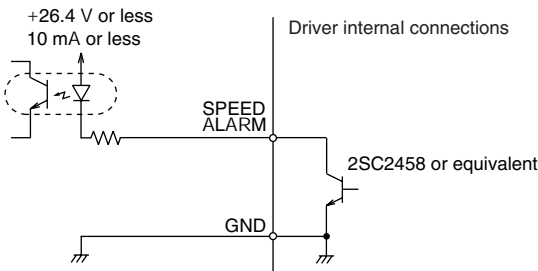

---

## Input signals and output signals

---

**⚠ Caution** • Do not perform the motor's starting and stopping operations by turning the power on and off. Perform them by inputting START/STOP and RUN/BRAKE. This may cause injury or damage to the equipment.

---

### Note

- The input signals (START/STOP, RUN/BRAKE, CW/CCW, INT.VR/ EXT, ALARM-RESET) must be ON for at least 10 ms. It may cause malfunction of the motor.
- The motor temperature rise is sharper as friction load and inertial load are higher, and start, instantaneous stop and reversing frequency is higher. It must be used when motor case temperature does not exceed 90°C (194°F), and driver heat radiation plate temperature does not exceed 90°C (194°F).

### ■ START/STOP input and RUN/BRAKE input

To switch between motor running and instantaneous stop (or stop), use two signals.

	START/STOP input	RUN/BRAKE input	Motor behavior
Signal level	ON (L level)	ON (L level)	Running* <sup>1</sup>
	ON (L level)	OFF (H level)	Instantaneous stop
	OFF (H level)	ON (L level)	Stop* <sup>2</sup>

\*1 The motor speed can be made to reach the set speed by any one of the internal potentiometer, external potentiometer or external DC voltage.

\*2 The motor is stopped by inertia.

### Note

- The BRAKE takes precedence when START/STOP and RUN/BRAKE inputs are turned off (H level) simultaneously.
- Do not operate (ON/OFF-switch) the START/STOP input, RUN/BRAKE input and, CW/CCW input or INT.VR/EXT input simultaneously. After switching an input, allow a minimum interval of 10 ms before switching to another input.

### ■ START/STOP input

START is selected when the input is on (L level), and motor starts running. STOP is selected when the input is off (H level), and motor stops (Instantaneous stop function is not provided.).

## ■ RUN/BRAKE input

RUN is selected when the input is on (L level), and motor starts running. BRAKE is selected when the input is off (H level), and motor stops instantaneously.

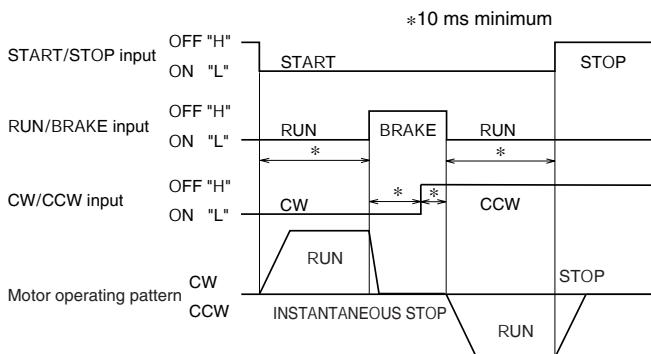

## ■ CW/CCW input

CW is selected when the input is on (L level). CCW is selected when the input is off (H level). The drive direction is the same as that of the motor output shaft when viewed from the motor output side.

### Note

Depending on the gearhead ratio, the drive direction of the gear output shaft may be opposite of that of the motor. Refer to catalogue.

## ■ INT.VR/EXT input

INT.VR is selected when the input is on (L level), and the setting speed of internal potentiometer is enabled. EXT is selected when the input is off (H level), and the setting speed of external potentiometer or external DC voltage is enabled. Switching this signal allows combined use of the external potentiometer or external DC voltage or two-speed switching operation. When the internal potentiometer is not used, there is no necessity even if there is no connection.

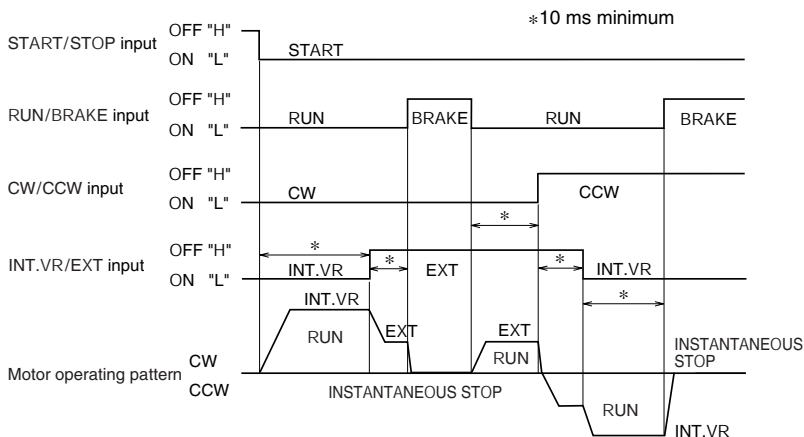

## ■ALARM-RESET input

When the motor is stopped, turn on this signal (L level); then turn it off (H level). This will allow ALARM to be reset.

Before inputting the ALARM RESET, reset either the START/STOP or RUN/BRAKE input to the OFF (H level). If both are ON (L level), ALARM-RESET input will not be accepted.

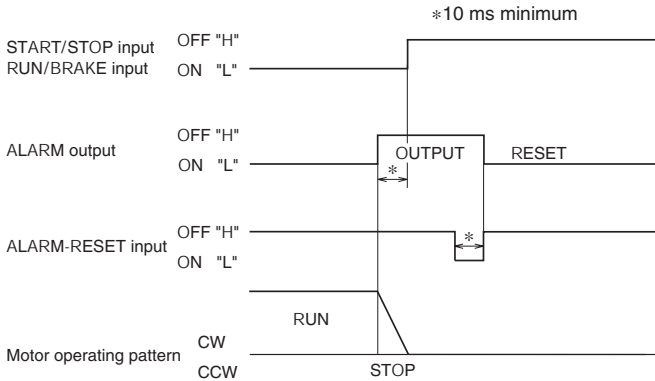

The motor having stopped halfway during operation due to activation of the driver protection function can be moved to a specified position or to the home position by this function.

After completion of motor travel, check why the alarm was issued. Restart the operation after removing the cause for alarm.

The ALARM can also be reset when the power is cycled.

For ALARM conditions, see page 26.

### Note

The START/STOP input and RUN/BRAKE input are not accepted until the ALARM output is reset.



## ■ SPEED OUT output

Pulse signals (pulse width: 0.3 ms) of 30 pulses per revolution of the motor output shaft are output in synchronism with the motor drive.

Motor speed can be calculated by measuring the SPEED output frequency.

$$\text{Motor speed}^* \text{ (r/min)} = \frac{\text{SPEED output frequency [Hz]}}{30} \times 60$$

$$\text{SPEED output frequency} = \frac{1}{T}$$

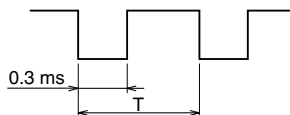

\* The speed of the gear output shaft of a pinion shaft type, geared type or combination type is obtained by dividing the motor speed by the gear ratio.

## ■ Timing chart

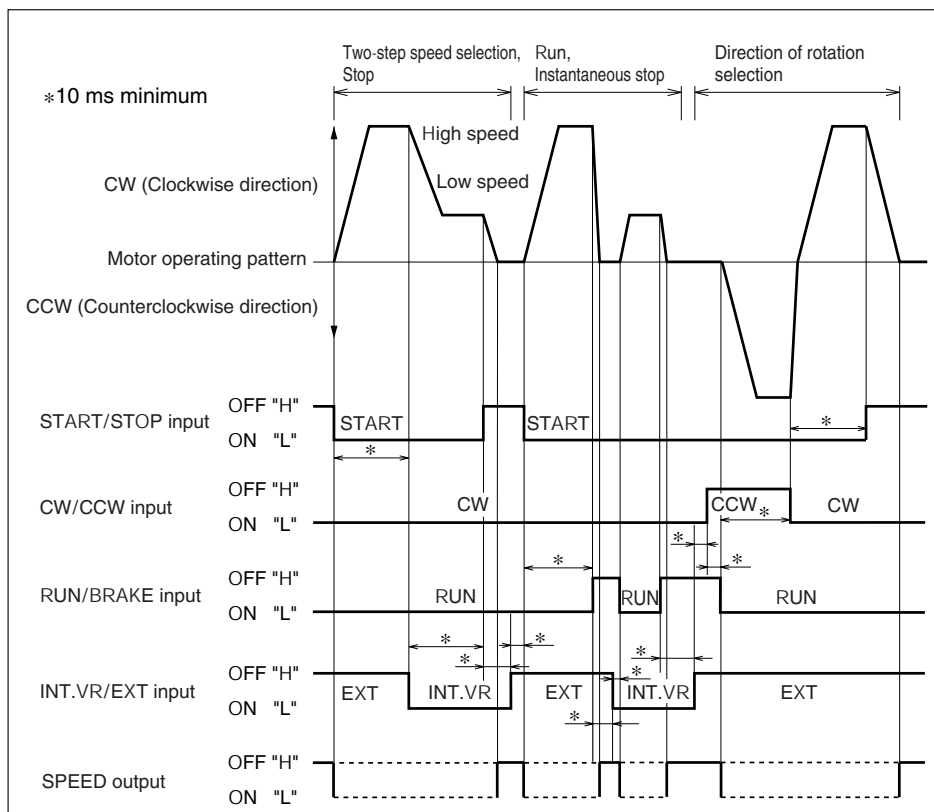

The direction of rotation is the case of the motor alone. It depends on the gear ratio.

---

## ■ALARM output

The protection function of the driver activates in following cases, and the ALARM output is turned off (H level), thereby stopping the motor. In this case, you can check the contents of the protection function which was operating by the number of LED flashes. The LED lights for 0.3 s and goes off for 0.3 s. After a specified number of flashes, flashing is performed at intervals of 1.5 s.

---

**⚠ Warning** • When the driver's protection function is triggered, first remove the cause and then clear the protection function. Continuing the operation without determining the cause of the problem may cause malfunction of the motor, leading to injury or damage to equipment.

---

### ◆Overload protection function (two flashes of LED)

When a load in excess of the rated torque is applied to the motor for about 5 s or more, or when the motor running/instantaneous stop and drive direction switching is repeated in a short time.

### ◆Open-phase protection function (three flashes of LED)

Prevents motor malfunction when the sensor cable within the motor cable is disconnected during motor operation. (An alarm signal will not be output while the motor is at a standstill.)

### ◆Overvoltage protection function (four flashes of LED)

When the motor is used in an elevating/lowering application or with a load in excess of the permissible load inertia, or when voltage applied to the driver has exceeded the voltage setting (24 VDC) by 15% or greater.

### ◆Insufficient voltage protection function (five flashes of LED)

When voltage applied to the driver is less than the voltage setting (24 VDC) by 25% or greater.

### ◆Overspeed protection function (six flashes of LED)

When motor speed has reached an excess of 3500 r/min.

If the ALARM output is connected as illustrated by the example of connection given on page 21, the level will be low when the driver is normal (ON), and will be high during ALARM output (OFF).

When the ALARM output is off (H level), remove the cause for activation of the protection function (refer to the number of times of LED flashing) after motor running has stopped. After remove the cause for activation of the protection function, reset the ALARM (For ALARM-RESET input, see page 24.).

## Note

The START/STOP input and RUN/BRAKE input are not accepted when the ALARM is off (H level).

# Setting the running speed

In addition to the driver internal potentiometer, the external potentiometer or external DC voltage can be used to set the motor running speed. The motor speed range is from 100 to 3000 r/min for the case of the motor alone.

Two running speeds can be set by combining the internal potentiometer and external potentiometer, or the internal potentiometer and external DC voltage.

## ■ Setting by internal potentiometer

This potentiometer is used when running speed setting is not frequently changed, or when two-step speed switching is performed in combination with external speed setting. Use a precision screw driver for this adjustment. Clockwise rotation will increase the set speed.

The speed is set to 0 r/min at time of shipment.

When the motor is driven at the speed set by the internal potentiometer, turn on the INT.VR/EXT input (L level).

When you want to use only the internal speed setting potentiometer to set the operation speed, you do not have to connect the VRH, VRM and VRL.

## ■ Setting by external potentiometer

This potentiometer is used when the speed is set away from the driver or when two-step speed switching is performed in combination with the internal potentiometer. Use the optional **PAVR-20KZ** as the external potentiometer.

Clockwise rotation will increase the set speed.

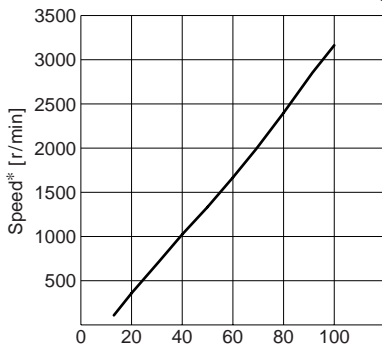

External potentiometer graduation  
External potentiometer graduation - speed characteristics (typical value)

External potentiometer **PAVR-20KZ**  
(Option)

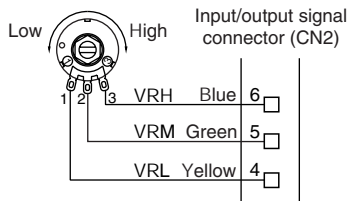

\* Indicates the speed of the motor alone. The speed of the gear output shaft of a geared type or combination type is obtained by dividing the motor speed by the gear ratio.

To drive the motor at the speed set on the external potentiometer, turn off the INT.VR/EXT input (H level).

- To set the running speed only by the external potentiometer, there is no problem if the INT.VR/EXT input is not connected.
- To perform operation by switching the motor running speed, use the INT.VR/EXT to switch the external potentiometer and internal potentiometer.

## Note

To use a shielded cable for connection with the external potentiometer, connection should be made close to the input/output signal cable connector. Connect the shielded wire to the pin No.3 GND.

### ■ Setting by external DC voltage

This method is used to set the speed by the D/A output of a programmable controller or to perform two-step speed switching in combination with the internal potentiometer.

For external DC voltage, use DC power supply (0 to 5 VDC, 1 mA or more) where the primary and secondary sides are provided with reinforced insulation.

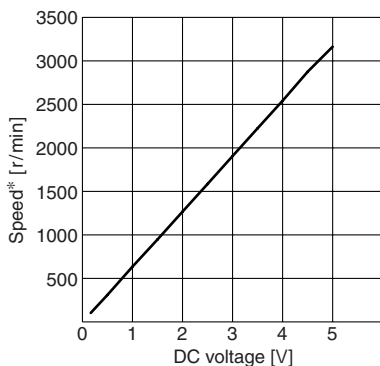

External DC voltage - speed characteristics (typical value)

\* Indicates the speed of the motor alone. The speed of the gear output shaft of a geared type or combination type is obtained by dividing the motor speed by the gear ratio.

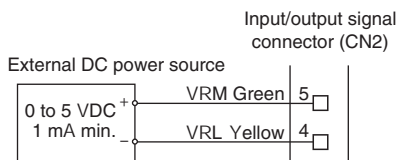

To drive the motor set at the external DC voltage, turn off the INT.VR/EXT input (H level).

- To set the running speed only by the external speed setter, there is no problem if the INT.VR/EXT input is not connected.
- To perform operation by switching the motor running speed, use the INT.VR/EXT to switch the external DC voltage and internal potentiometer.

## Note

- The external DC power supply voltage must not exceed 5 VDC. Otherwise, the driver may be damaged.
- When connecting the external DC power supply, sufficient care must be taken not to mistake power polarity. Connection with incorrect polarity may damage the motor.
- To use a shielded cable for connection with the external DC power supply, connection should be made close to the input/output signal cable connector. Connect the shielded wire to the pin No.3 GND.

---

# Inspection

It is recommended to check the following four items after motor operation. If any failure is found, stop the operation, and please contact your local sales office.

- Check if abnormal noise is produced from the motor bearing section (ball bearing).
- Check if abnormal noise is produced from the gearhead bearing (ball bearing) and gear meshing section.
- Check if the motor cable is damaged or stressed. Also check if the connections with the driver are loosened.
- Check if there is any misalignment between motor (gearhead) output and load shafts.
- Check if dust is deposited on the driver.

## Note

Conduct the insulation resistance measurement or withstand voltage test separately on the motor and the driver.

Conducting the insulation resistance measurement or withstand voltage test with the motor and driver connected may result in injury or damage to the product.

# Trouble diagnosis and countermeasures

During motor running, the motor and driver may not operate correctly due to speed setting error or connection error. If normal motor operation cannot be ensured, see the following description and take appropriate countermeasures. If normal operation cannot be ensured even after that, please contact your local sales office.

Phenomenon	Estimated cause	Measure
The motor fails to turn.	Either START/STOP input or RUN/BRAKE input is not set to the L level.	Make sure that both START/STOP input or RUN/BRAKE input are set to the L level.
	The internal potentiometer is not adjusted.	Turn the internal potentiometer slightly in the clockwise direction. The speed is set to 0 r/min at time of shipment.
	When the internal potentiometer is used, INT.VR/EXT input is not set to the L level.	Set the INT.VR/EXT input to the L level. When the INT.VR/EXT input is set to the L level, the internal potentiometer is selected.
	The external potentiometer contact is faulty.	Check for connection of the external potentiometer.
	When the external potentiometer is used, INT.VR/EXT input is not set to the H level.	Set the INT.VR/EXT input to the H level. When the INT.VR/EXT input is set to the H level, the external potentiometer is selected.
	The external DC voltage contact is faulty.	Check for connection of the external DC voltage.
	When an external DC voltage is used, INT.VR/EXT input is not set to the H level.	Set the INT.VR/EXT input to the H level. When the INT.VR/EXT input is set to the H level, external DC voltage is selected.
The motor fails to turn. The motor stops halfway.	Protection function has activated.	Count the LED flashings. See page 26 and check the causes in conformity to the activated protection function. Take the appropriate measures.

Phenomenon	Estimated cause	Measure
The motor is driven opposite of the specified direction.	Incorrect CW/CCW input or faulty connection.	The motors driven in the CW direction when the CW/CCW input is set to the L level. CCW direction when the CW/CCW input is set to the H level.
	Speed reduction ratios 30:1, 50:1 and 100:1 are used in the combination type, or 20:1, and 30:1 are used in the geared type.	When these speed reduction ratios are used, drive direction is opposite to that of the motor. Reverse the CW/CCW input operation.
Unstable motor operation with big vibration	The motor (gearhead) output shaft and load shaft are not aligned with each other.	Make sure that the motor (gearhead) output shaft and load shaft are connected in an appropriate manner.
	Affected by noise	Check for running only with the motor, driver and controller required for running. If noise influence has been confirmed, take the appropriate measures such as separation from noise generating source, re-connection of wiring, replacement of the signal cable by a shielded cable, and installation of a ferrite core.
The motor fails to stop instantaneously.	The motor is stopped by START/STOP input.	Stop the motor by RUN/BRAKE input.
	Load inertia may be excessive.	For this check, increase the frictional load or reduce the load inertia.

- Unauthorized reproduction or copying of all or part of this manual is prohibited. If a new copy is required to replace an original manual that has been damaged or lost, please contact your nearest Oriental Motor branch or sales office.
- Oriental Motor shall not be liable whatsoever for any problems relating to industrial property rights arising from use of any information, circuit, equipment or device provided or referenced in this manual.
- Characteristics, specifications and dimensions are subject to change without notice.
- While we make every effort to offer accurate information in the manual, we welcome your input. Should you find unclear descriptions, errors or omissions, please contact the nearest office.
- **Orientalmotor** is a trademark of Oriental Motor Co., Ltd.  
Other product names and company names mentioned in this manual may be trademarks or registered trademarks of their respective companies and are hereby acknowledged. The third-party products mentioned in this manual are recommended products, and references to their names shall not be construed as any form of performance guarantee. Oriental Motor is not liable whatsoever for the performance of these third-party products.

© Copyright ORIENTAL MOTOR CO., LTD. 2007

- Please contact your nearest Oriental Motor office for further information.

ORIENTAL MOTOR U.S.A. CORP.  
 Technical Support Line Tel:(800)468-3982  
 Available from 7:30 AM to 5:00 PM, P.S.T.  
 E-mail: techsupport@orientalmotor.com  
 www.orientalmotor.com

ORIENTAL MOTOR (EUROPA) GmbH  
 Headquarters and Düsseldorf Office  
 Tel:0211-5206700 Fax:0211-52067099  
 Munich Office  
 Tel:08131-59880 Fax:08131-598888  
 Hamburg Office  
 Tel:040-76910443 Fax:040-76910445

ORIENTAL MOTOR (UK) LTD.  
 Tel:01256-347090 Fax:01256-347099

ORIENTAL MOTOR (FRANCE) SARL  
 Tel:01 47 86 97 50 Fax:01 47 82 45 16

ORIENTAL MOTOR ITALIA s.r.l.  
 Tel:02-93906346 Fax:02-93906348

TAIWAN ORIENTAL MOTOR CO.,LTD.  
 Tel:(02)8228-0707 Fax:(02)8228-0708

SINGAPORE ORIENTAL MOTOR PTE LTD  
 Tel:(6745)7344 Fax:(6745)9405

ORIENTAL MOTOR (MALAYSIA) SDN. BHD.  
 Tel:(03)22875778 Fax:(03)22875528

INA ORIENTAL MOTOR CO.,LTD.  
 KOREA  
 Tel:(032)822-2042~3 Fax:(032)819-8745

ORIENTAL MOTOR CO.,LTD.  
 Headquarters Tokyo, Japan  
 Tel:(03)3835-0684 Fax:(03)3835-1890