



Brushless Motor and Driver Package

BMU Series

200 W

OPERATING MANUAL



Thank you for purchasing an Oriental Motor product.

This Operating Manual describes product handling procedures and safety precautions.

- Please read it thoroughly to ensure safe operation.
- Always keep the manual where it is readily available.



The "NexBL" is a new brushless motor offered by Oriental Motor. The utmost performance required for the motor is pursued, and all the structures of the motor have been renewed. This product achieves more compact, higher power and higher efficiency than ever before.

Only qualified and educated personnel should work with the product.

Use the product correctly after thoroughly reading the section "1 Safety precautions".

The items under **Note** contain important handling instructions that the user should observe to ensure safe use of the product. **Note** is described in the related handling items.

The product described in this manual has been designed and manufactured to be incorporated in general industrial equipment. Do not use for any other purpose. Oriental Motor Co., Ltd. is not responsible for any damage caused through failure to observe this warning.

Table of contents



1	Safety precautions.....	3	7	Operating by programmable controller.....	19
2	Precautions for use	5	7.1	Operating	19
3	Preparation	6	7.2	Operating with multiple speeds	21
3.1	Checking the product	6	7.3	Switching the motor rotation direction.....	22
3.2	How to identify the product model.....	6	8	Convenient functions.....	23
3.3	Combinations of motors and drivers	6	8.1	Functions list	23
3.4	Names and functions of parts	7	8.2	Setting items and panel displays.....	24
4	Installation	8	8.3	Parameter list	26
4.1	Installation location.....	8	8.4	Items displayed on the driver	28
4.2	Installing the motor.....	8	8.5	Setting the operation data	29
	■ Installing the combination type • parallel shaft gearhead.....	8	8.6	Setting the acceleration time and deceleration time.....	30
	■ Removing/Installing the gearhead.....	9	8.7	Data locking for the set data	31
	■ Installing a load	10	8.8	Limiting the setting range of the rotation speed	31
	■ Permissible radial load and permissible axial load.....	10	8.9	Holding a load at motor standstill	32
4.3	Installing the driver	11	9	Alarms and warnings.....	33
5	Connection	12	9.1	Alarms	33
5.1	Connecting the power supply	12	9.2	Warnings	35
5.2	Connecting the motor	12	10	Troubleshooting and remedial actions	36
*5.3	Grounding	13	11	Inspection	37
5.4	Connecting the I/O signals	13	12	Accessories (sold separately)	38
5.5	Connection example	15	13	Reference.....	39
	■ Connection example for when using switches and relays	15	13.1	Standard and CE Marking.....	39
	■ Connection example for I/O signals and programmable controller.....	16	13.2	Installing and wiring in compliance with EMC Directive	40
6	Operating by front panel.....	17	13.3	Specifications	42
6.1	Connecting	17			
6.2	Inputting the power.....	17			
6.3	Operating	18			

* Be sure to ground the Protective Earth Terminal ⊕ (ground terminal) to ensure the safe use of the product.

Refer to "5.3 Grounding" for details, and ground securely.



1 Safety precautions

The precautions described below are intended to prevent danger or injury to the user and other personnel through safe, correct use of the product. Please read and understand these precautions thoroughly before using the product.

 Warning	Handling the product without observing the instructions that accompany a “Warning” symbol may result in serious injury or death.
 Caution	Handling the product without observing the instructions that accompany a “Caution” symbol may result in injury or property damage.

Warning

General

- Do not use the product in explosive or corrosive environments, in the presence of flammable gases or near combustibles. Doing so may result in fire, electric shock or injury.
- Only qualified and educated personnel should be allowed to perform installation, connection, operation and inspection/troubleshooting of the product. Handling by unqualified and uneducated personnel may result in fire, electric shock, injury or equipment damage.
- Do not transport, install the product, perform connections or inspections when the power is on. Always turn the power off before carrying out these operations. Failure to do so may result in electric shock or equipment damage.
- The terminals on the driver marked with   symbol indicate the presence of high voltage. Do not touch these terminals while the power is on. Doing so may result in fire or electric shock.
- Do not use a motor in a vertical application. If the driver’s protection function is activated, the motor will stop and the moving part of the equipment will drop, thereby causing injury or equipment damage.
- If the driver protective function was activated, remove the cause and reset the protective function. Continuing the operation without removing the cause of the problem may result in malfunction of the motor and driver, leading to injury or damage to equipment.

Installation

- The motor and driver are Class I equipment.
When installing the motor and driver, connect their Protective Earth Terminals. Failure to do so may result in electric shock.

Connection

- Securely connect and ground in accordance with the connection examples. Failure to do so may result in fire or electric shock.
- Do not forcibly bend, pull or pinch the cables. Doing so may result in fire or electric shock.
- Do not machine or modify the motor cable or connection cable. Doing so may result in electric shock or fire.
- Be sure to observe the specified cable sizes. Use of unspecified cable sizes may result in fire.

Operation

- Use a motor (gearhead) and driver only in the specified combination. An incorrect combination may cause in fire, electric shock or equipment damage.
- Keep the input power voltage of the driver within the specified range. Failure to do so may result in fire or electric shock.

Maintenance and inspection

- Always turn off the power before performing maintenance/inspection. Failure to do so may result in electric shock.
- Do not touch the motor or driver when conducting insulation resistance measurement or dielectric strength test. Accidental contact may result in electric shock.
- Do not touch the connection terminals on the driver immediately (within 1 minute) after the power is turned off. Residual voltage may cause electric shock.
- Regularly check the openings in the driver for accumulated dust. Accumulated dust may cause fire.

Repair, disassembly and modification

- Do not disassemble or modify the motor (gearhead) and driver. Doing so may result in electric shock, injury or equipment damage. Should you require inspection or repair of internal parts, please contact the Oriental Motor branch or sales office from which you purchased the product.

 **Caution**

General

- Do not use the motor (gearhead) and driver beyond the specifications. Doing so may result in fire, electric shock, injury or damage to equipment.
- Do not insert an object into the openings in the driver. Doing so may result in fire, electric shock or injury.
- Do not touch the motor (gearhead) or driver while operating or immediately after stopping.
The surface of the motor (gearhead) or driver may be hot and cause a skin burn(s).

Installation

- Do not leave anything around the motor and driver that would obstruct ventilation. Doing so may result in damage to equipment.
- Do not carry the product by holding the motor (gearhead) output shaft or any of the cables. Doing so may result in injury.
- Do not touch the motor output shaft (tip or pinion) with bare hands. Doing so may result in injury.
- When assembling the motor (pinion shaft) with the gearhead, exercise caution not to pinch your fingers or other parts of your body between the motor and gearhead. Injury may result.
- Securely install the motor (gearhead) and driver to their respective mounting plates. Inappropriate installation may cause the motor/driver to detach and fall, resulting in injury or equipment damage.
- Provide a cover on the rotating part (output shaft) of the motor (gearhead). Failure to do so may result in injury.
- When installing the motor (gearhead) in the equipment, exercise caution not to pinch your fingers or other parts of your body between the equipment and motor or gearhead. Injury may result.
- Securely install the load on the motor (gearhead) output shaft. Inappropriate installation may result in injury.

Connection

- Be sure to ground the motor and driver to prevent them from being damaged by static electricity. Failure to do so may result in fire or damage to equipment.
- For the power supply of I/O signals, use a DC power supply with reinforced insulation on its primary and secondary sides. Failure to do so may result in electric shock.

Operation

- Provide an emergency stop device or emergency stop circuit external to the equipment so that the entire equipment will operate safely in the event of a system failure or malfunction. Failure to do so may result in injury.
- Immediately when trouble has occurred, stop running and turn off the driver power. Failure to do so may result in fire, electric shock or injury.
- Do not touch the rotating part (output shaft) when operating the motor. Doing so may result in injury.
- The motor surface temperature may exceed 70 °C (158 °F) even under normal operating conditions.
If the operator is allowed to approach a running motor, attach a warning label as shown in the figure in a conspicuous position. Failure to do so may result in skin burn(s).
- Use an insulated screwdriver to adjust the acceleration/ deceleration time potentiometer in the driver. Failure to do so may result in electric shock.



Warning label

Disposal

- To dispose of the motor (gearhead) or driver, disassemble it into parts and components as much as possible and dispose of individual parts/components as industrial waste.

■ **Warning information**

A warning label with handling instructions is attached on the driver. Be sure to observe the instructions on the label when handling the driver.

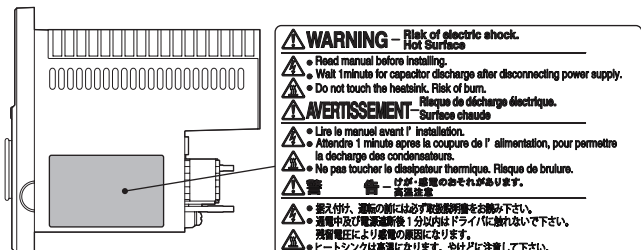

2 Precautions for use

This chapter covers limitations and requirements the user should consider when using the product.

- **Connect protective devices to the power line**

Connect a circuit breaker or earth leakage breaker to the driver's power line to protect the primary circuit. If an earth leakage breaker is to be installed, use one incorporating high-frequency noise elimination measures. Refer to "Preventing leakage current" below for the selection of protective devices.

- **Do not perform vertical drive (gravitational operation)**

The product will not be able to control the motor speed if an operation that the motor output shaft is externally rotated is performed (vertical drive etc.). Also, if vertical drive is performed, since the inverter primary voltage of the circuit may exceed the permissible range, the protective function may be activated. As a result, the motor may coast to a stop and the load may fall.

- **Do not use a solid-state relay (SSR) to turn on/off the power**

A circuit that turns on/off the power via a solid-state relay (SSR) may damage the motor and driver.

- **Do not conduct the insulation resistance measurement or dielectric strength test with the motor and driver connected**

Conducting the insulation resistance measurement or dielectric strength test with the motor and driver connected may result in damage to the product.

- **Grease measures**

On rare occasions, a small amount of grease may ooze out from the gearhead.

If there is a concern over possible environmental damage resulting from the leakage of grease, provide an oil tray or similar oil catching mechanism in order not to cause a secondary damage.

Oil leakage may lead to problems in the customer's equipment or products.

- **Caution when using under low temperature environment**

When an ambient temperature is low, since the load torque may increase by the oil seal or viscosity increment of grease used in the gearhead, the output torque may decrease or an overload alarm may generate. However, as time passes, the oil seal or grease is warmed up, and the motor can be driven without generating an overload alarm.

- **Preventing leakage current**

Stray capacitance exists between the driver's current-carrying line and other current-carrying lines, the earth and the motor, respectively. A high-frequency current may leak out through such capacitance, having a detrimental effect on the surrounding equipment. The actual leakage current depends on the driver's switching frequency, the length of wiring between the driver and motor, and so on. When connecting an earth leakage breaker, use one of the following products offering resistance against high frequency current:

[Mitsubishi Electric Corporation: NV series]

- **Noise elimination measures**

Provide noise elimination measures to prevent a motor or driver malfunction caused by external noise.

For more effective elimination of noise, use a shielded I/O signal cable or attach ferrite cores if a non-shielded cable is used. Refer to p.40 for the noise elimination measures.

- **Connecting the motor and driver**

Use a connection cable (supplied or accessory) when extending the wiring distance between the motor and driver.

- **The driver uses semiconductor elements, so be extremely careful when handling them**

Electrostatic discharge can damage the driver.

Be sure to ground the motor and driver to prevent them from being damaged by electric shock or static electricity.

- **Saving data to the non-volatile memory**

The display blinks while pressing the setting dial to set the data or initializing the data (about 5 seconds). Do not turn off the power supply while the display is blinking. Doing so may abort writing the data and cause an EEPROM error alarm to generate.

The non-volatile memory can be rewritten approximately 100,000 times.

3 Preparation

This chapter explains the items you should check, as well as the names and functions of each part.

3.1 Checking the product

Verify that the items listed below are included. Report any missing or damaged items to the branch or sales office from which you purchased the product.

- | | |
|---|--|
| <input type="checkbox"/> Motor1 unit
(With a gearhead, only for combination type) | <input type="checkbox"/> CN1 connector (3 pins).....1 pc |
| <input type="checkbox"/> Driver1 unit | <input type="checkbox"/> CN4 connector (12 pins).....1 pc |
| <input type="checkbox"/> Connection cable1 pc
(Only models with a supplied connection cable) | <input type="checkbox"/> <u>OPERATING MANUAL</u> (this document)1 copy |
| <input type="checkbox"/> Hexagonal socket head screw set1 set
(Hexagonal socket head screw, flat washer, spring washer, 4 pcs. each) | <input type="checkbox"/> <u>QUICK START GUIDE</u>1 copy |
| <input type="checkbox"/> Parallel key1 pc
(The parallel key is fixed to the gearhead output shaft.) | |

3.2 How to identify the product model

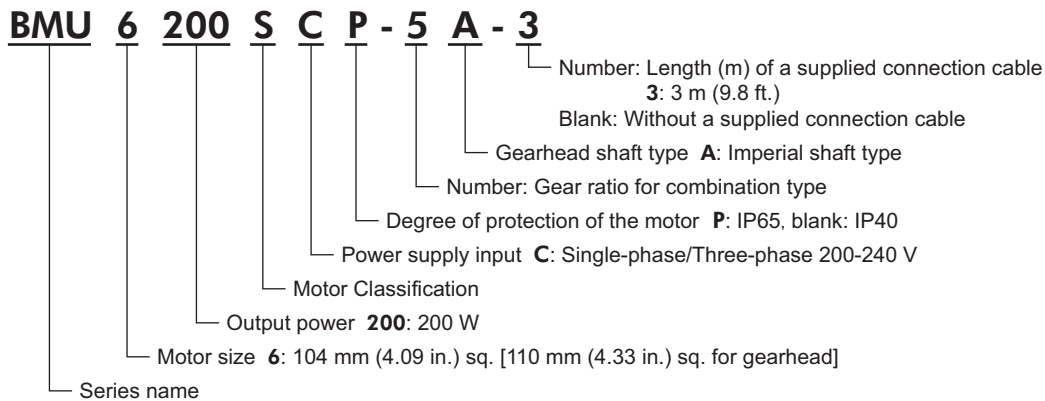

3.3 Combinations of motors and drivers

Verify the model number of the purchased product against the number shown on the package label.

Check the model number of the motor, gearhead and driver against the number shown on their nameplates, respectively.

■ indicates the cable length (-3) when the connection cable is supplied.

■ Combination type • parallel shaft gearhead

- in the model name indicates a number representing the gear ratio.
- The combination types come with the motor and gearhead pre-assembled.

Output power	Degree of protection of the motor	Power supply voltage	Model	Motor model	Gearhead model	Driver model
200 W	IP40	Single-phase/Three-phase 200-240 V	BMU6200SC-□A■	BLM6200S-GFV	GFV6G□A	BMUD200-C
	IP65 *	Single-phase/Three-phase 200-240 V	BMU6200SCP-□A■	BLM6200SP-GFV		

* Excluding the connector part.

3.4 Names and functions of parts

■ Motor

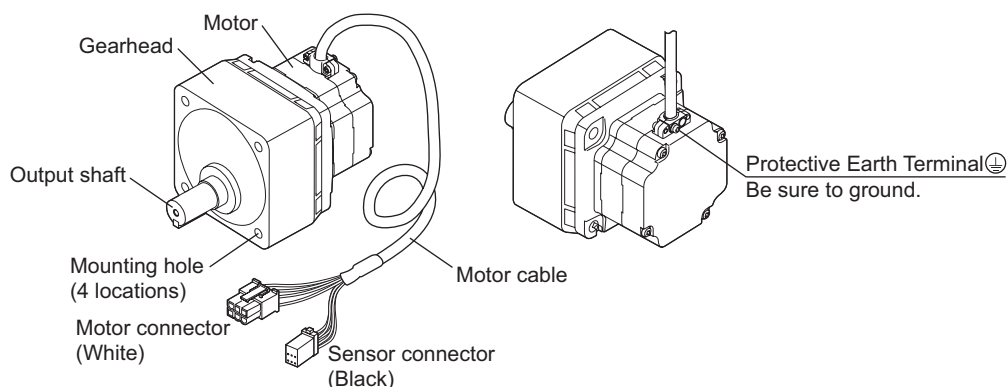

■ Driver

Driver front side: When the front panel is attached

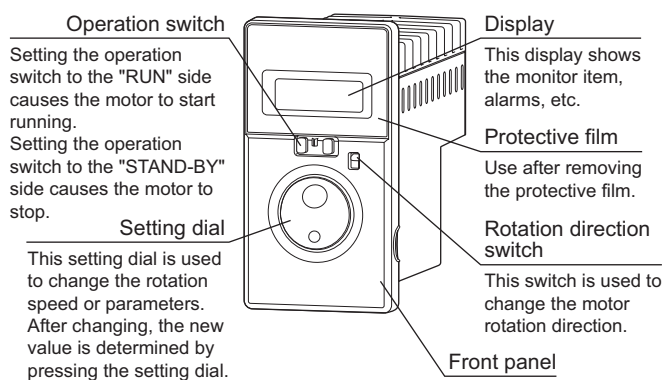

Driver front side: When the front panel is removed

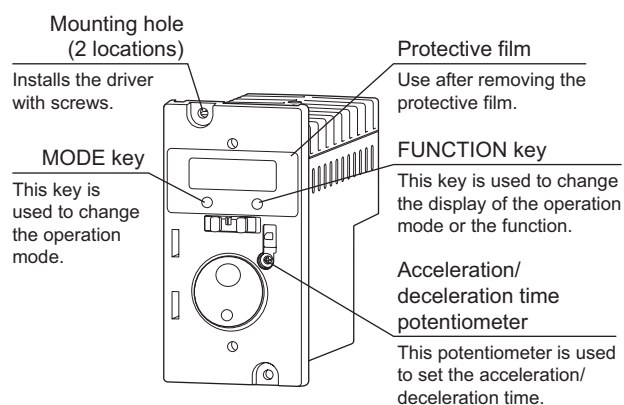

Driver rear side

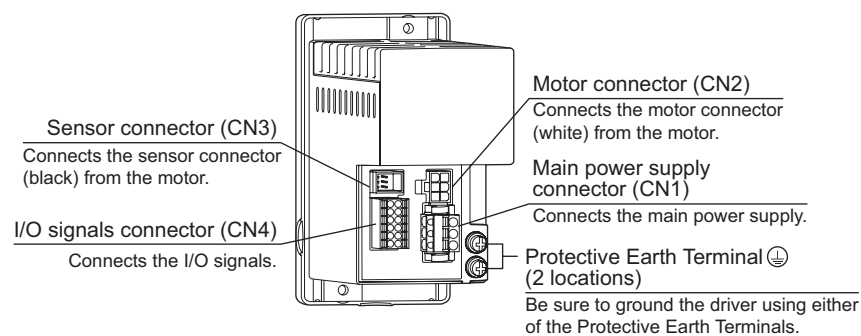

4 Installation

This chapter explains the installation location and installation methods of the motor and driver, as well as how to install a load.

4.1 Installation location

Install the motor in a well-ventilated place where they can be inspected easily and the following conditions are satisfied:

[Common conditions]

- Operating ambient temperature: 0 to +40 °C (+32 to +104 °F) (non-freezing)
- Operating ambient humidity: 85% or less (non-condensing)
- Area that is free of explosive atmosphere or toxic gas (such as sulfuric gas) or liquid
- Area not exposed to direct sun
- Area free of excessive amount of dust, iron particles or the like
- Area free of excessive salt
- Area not subject to continuous vibration or excessive shocks
- Area free of excessive electromagnetic noise (from welders, power machinery, etc.)
- Area free of radioactive materials, magnetic fields or vacuum
- Altitude: Up to 1000 m (3300 ft.) above sea level

[Degree of protection: IP65 rated motor]

- Indoors
- Not exposed to oil (oil droplets) or chemicals.
This motor can be used in an environment that is splashed with water (excluding the connector part).
Not available for use under high pressure jets of water or immersion in water.

[Degree of protection: IP40 rated motor]

- Inside an enclosure installed indoors (provide a ventilation hole)
- Area not subject to splashing water (rain, water droplets), oil (oil droplets) or other liquids

4.2 Installing the motor

■ Installing the combination type • parallel shaft gearhead

Secure the motor with hexagonal socket head screws (supplied) through the four mounting holes provided. Do not leave a gap between the motor and mounting plate.

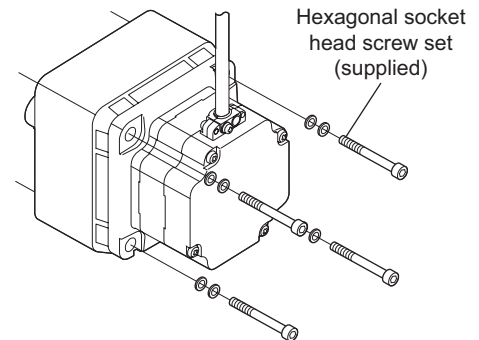

• Hexagonal socket head screw set (supplied)

Model	Gear ratio	Hexagonal socket head screw (Material: Stainless steel)			Tightening torque [N·m (lb-in)]
		Screw size	L1 [mm (in.)]	L2 [mm (in.)]	
BMU6200	5 to 20	5/16-18UNC	88.9 (3.5)	16 (0.63)	12 (106)
	30, 50		101.6 (4)	17 (0.67)	
	100, 200		114.3 (4.5)	15 (0.59)	

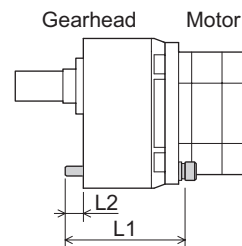

• Recommended mounting hole dimensions [Unit: mm (in.)]

Model	∅A	B	∅C	D	E
BMU6200	120 (4.72)	84.86 (3.341)	41 ^{+0.025} ₀ (1.6142 ^{+0.0010} ₀)	20 (0.79)	5/16-18UNC

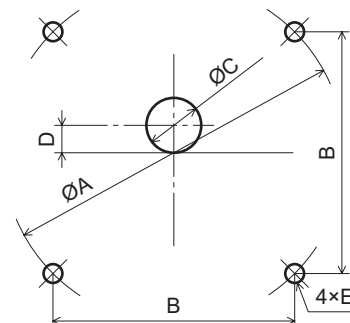

■ Removing/Installing the gearhead

See the following steps to replace the gearhead or to change the cable position.

1. Removing the gearhead

Remove the hexagonal socket head screws assembling the motor and gearhead and detach the motor from the gearhead.

- Assembly hexagonal socket head screw

Model	Screw size	Tightening torque
BMU6200	M3	0.6 N·m (5.3 lb-in)

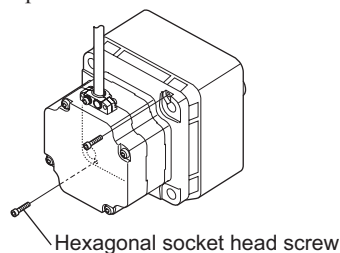

2. Installing the gearhead

Using the pilot sections of the motor and gearhead as guides, install the gearhead to the motor and tighten the hexagonal socket head screws.

Confirm that no gaps remain between the motor flange surface and the end face of the gearhead pilot section.

At this time, the motor cable position can be changed to a desired 90° direction.

When installing the gearhead, slowly rotate it clockwise/counterclockwise to prevent the pinion of the motor output shaft from contacting the side panel or gear of the gearhead.

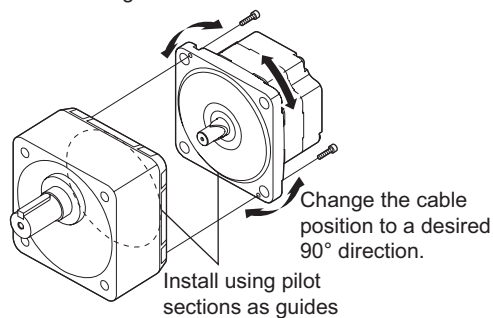

Note

- Do not forcibly assemble the motor and gearhead. Also, do not let metal objects or other foreign matter enter the gearhead. The pinion of the motor output shaft or gear may be damaged, resulting in noise or shorter service life.
- Do not allow dust to attach to the pilot sections of the motor and gearhead. Also, assemble the motor and gearhead carefully by not pinching the O-ring at the motor pilot section. If the O-ring is crushed or severed, grease may leak from the gearhead.
- The hexagonal socket head screws assembling the motor and gearhead are used to attach the motor and gearhead temporarily. When installing the motor/gearhead assembly, be sure to use the supplied hexagonal socket head screws.

■ Installing a load

When installing a load on the motor (gearhead), pay attention to the following points.

- Align the centerline of the motor output shaft (gearhead output shaft) with the centerline of the load.
- A key slot is provided on the output shaft of each combination type · parallel shaft gearhead.

Form a key slot on the load side and secure the load using the supplied parallel key.

Note

- When coupling the motor (gearhead) with a load, pay attention to centering, belt tension, parallelism of pulleys, etc. Also, firmly secure the tightening screws of the coupling or pulleys.
- When installing a load, do not damage the motor output shaft (gearhead output shaft) or bearing. Forcing in the load by driving it with a hammer, etc., may break the bearing. Do not apply any excessive force to the output shaft.
- Do not modify or machine the motor (gearhead) output shaft. The bearing may be damaged or motor (gearhead) may break.

When using the output shaft end tapped hole of a gearhead

Use a tapped hole provided at the end of the output shaft as an auxiliary means for preventing the transfer mechanism from disengaging.

Gearhead model	Screw size	Effective depth
GFV6G□A	No.12-24UNC	12 mm (0.47 in.)

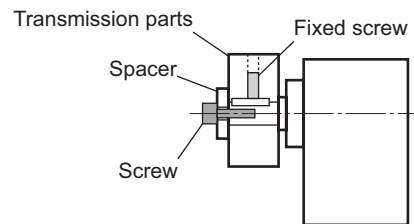

■ Permissible radial load and permissible axial load

The radial load and the axial load on the output shaft of the motor (gearhead) must be kept under the permissible values listed below.

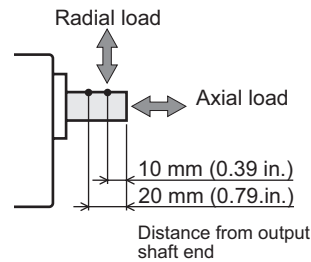

- Combination type · parallel shaft gearhead

Model	Gear ratio	Permissible radial load [N (lb.)]*		Permissible axial load [N (lb.)]
		Distance from tip of gearhead output shaft		
		10 mm (0.39 in.)	20 mm (0.79 in.)	
BMU6200	5 to 20	550 (123) [500 (112)]	800 (180) [700 (157)]	200 (45)
	30, 50	1000 (220) [900 (200)]	1250 (280) [1100 (240)]	300 (67)
	100, 200	1400 (310) [1200 (270)]	1700 (380) [1400 (310)]	400 (90)

* The values assume a rated speed of 3000 r/min or below. The values in [] are based on a rated speed of 4000 r/min.

Note

Failure due to fatigue may occur when the motor (gearhead) bearings and output shaft are subject to repeated loading by a radial or axial load that is in excess of the permissible limit.

4.3 Installing the driver

The driver is designed so that heat is dissipated via air convection and conduction through the enclosure. There must be a clearance of at least 25 mm (0.98 in.) and 50 mm (1.97 in.) clearances in the horizontal and vertical directions, respectively, between the driver and enclosure or other equipment within the enclosure.

■ Installation direction

Install the driver so that the front panel side of the driver is turned in the front direction or upward.

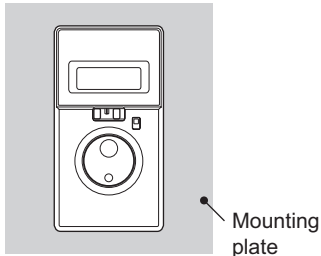

Front direction

Operating ambient temperature:
0 to +40 °C (+32 to +104 °F)

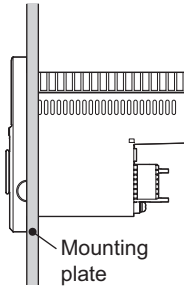

Upward direction

Operating ambient temperature:
0 to +40 °C (+32 to +104 °F)

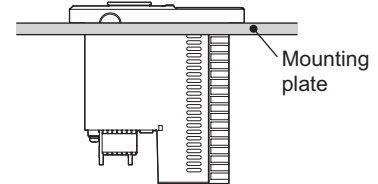

Note

- Do not install any equipment that generates a large amount of heat or noise near the driver.
- If the ambient temperature of the driver exceeds the upper limit of the operating ambient temperature, revise the ventilation condition or force-cool the area around the driver using a fan.

■ Installation method

Install the driver to a flat metal plate offering excellent vibration resistance.

Remove the front panel of the driver and secure the two mounting holes using screws and nuts (No.8-32UNC or M4: not supplied).

Tighten the screws until no gaps remain between the driver and mounting plate.

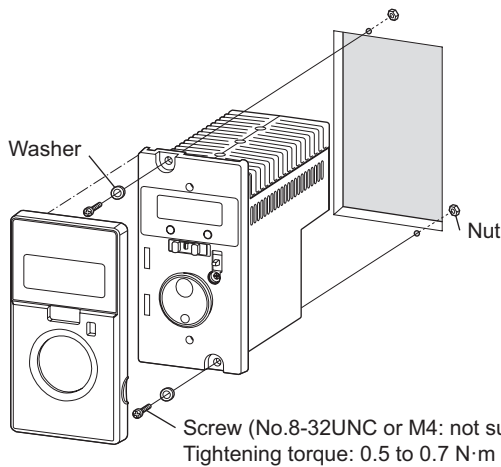

• Plate cutout for mounting

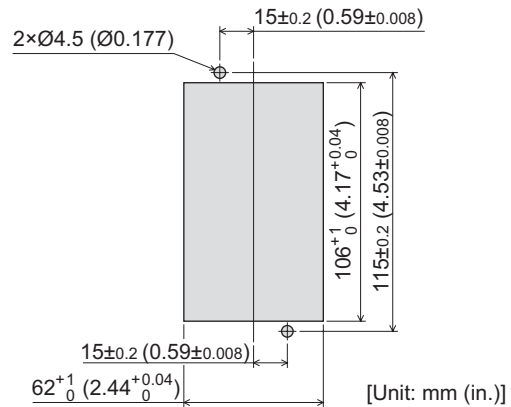

Note

- The space between the mounting hole section and front panel of the driver is 6 mm (0.24 in.). Therefore, the total height of the screw head and washer should be less than 6 mm (0.24 in.). The front panel cannot be installed if it is exceeded 6 mm (0.24 in.).
- If the washer is used, use the washer which outer diameter is 10 mm (0.39 in.) or less.

Removing and installing the front panel

Installing

Install the front panel after placing on the upper side of the driver front face.

Removing

Remove the front panel having the under side.

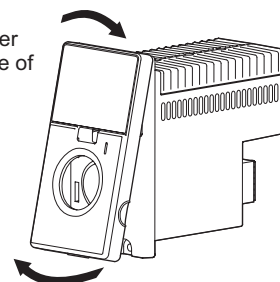

5 Connection

This chapter explains how to connect the driver and motor, I/O signals, and power supply, as well as the grounding method.

5.1 Connecting the power supply

The connection varies depending on the power supply voltage of the product. Connect the power supply cable to the CN1 as shown in the figure.

The power cable is not included. It is provided as an accessory (sold separately).(p.38)

Note Check the specification of the power supply voltage for the driver before applying a voltage. If a voltage exceeding the rated range is applied, the driver may be damaged.

Input power supply	Single-phase 200-240 V	Three-phase 200-240 V
Connecting method	Connect the live side to terminal L, and the neutral side to terminal N.	Connect the R, S and T phase lines to the L1, L2 and L3 terminals, respectively.

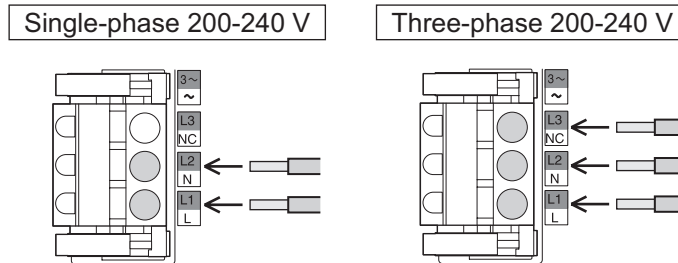

Connector model:
FKC2,5/3-ST-5,08-LR (PHOENIX CONTACT GmbH & Co. KG)

Connecting the lead wire

Connect to insert the lead wire to the connector.

- Applicable lead wire:
AWG18 to 14 (0.75 to 2.0 mm²)
- Length of the insulation cover which can be peeled: 10 mm (0.39 in.)
- Conductive material: Use only copper wire.

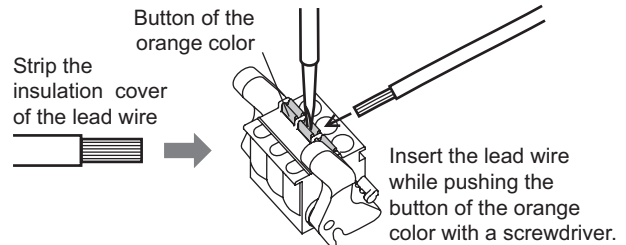

Crimp terminals can also be used to connect.
If crimp terminals are used, select the following terminals.

- Manufacturer: PHOENIX CONTACT GmbH & Co. KG
- Model: AI 0,75-10 [Conductor cross-sectional area: 0.65 to 0.82 mm² (AWG18)]
- AI 1-10 [Conductor cross-sectional area: 0.82 to 1.2 mm² (AWG18)]
- AI 1,5-10 [Conductor cross-sectional area: 1.25 to 1.8 mm² (AWG16)]
- AI 2,5-10 [Conductor cross-sectional area: 2.0 to 3.0 mm² (AWG14)]

■ Circuit breaker

Be sure to connect a circuit breaker to the power line of the driver to protect the primary circuit.
Rated current of protective device: Single-phase input 10 A, three-phase input 10 A
Circuit breaker: Mitsubishi Electric Corporation NF30

5.2 Connecting the motor

Connect the motor connector (white) of the motor cable to the CN2, and the sensor connector (black) to the CN3 on the driver. Check the pin assignment on p.38.

Use a connection cable (supplied or accessory) when extending the wiring distance between the motor and driver. The connection cable can be connected up to 2 pieces. The wiring distance between the motor and driver can be extended to a maximum of 10.5 m (34.4 ft.).

Note Ensure that the connector plugged in securely. Insecure connections may cause malfunction or damage to the motor or driver.

5.3 Grounding

Be sure to ground using the Protective Earth Terminal \oplus of the motor and the Protective Earth Terminal \oplus of the driver.

Note Be sure to ground the motor and driver. Failure to do so may result in electric shock or damage to the product.
Static electricity may cause damage to the product if the Protective Earth Terminals are not grounded.

Motor

Connect the Protective Earth Terminal \oplus on the motor to the ground near the motor.

Minimize the wiring length of the ground cable.

Ground terminal

- Applicable crimp terminal:
Round crimp terminal with insulation cover
- Thread size of terminal: M4
- Tightening torque: 1.2 N·m (10.6 lb-in)
- Applicable lead wire: AWG18 to 14 (0.75 to 2.0 mm²)

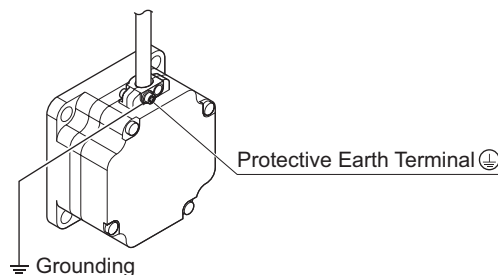
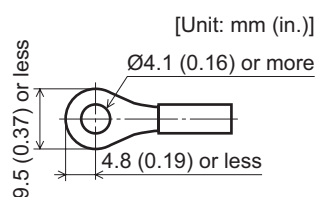

Driver

Two Protective Earth Terminals \oplus are provided on the driver. Ground either of the two Protective Earth Terminals \oplus near the driver. You can ground either of the two Protective Earth Terminals \oplus . The terminal that is not grounded is used as a service terminal. Use the service terminal according to your specific need, such as connecting it to the motor in order to ground the motor.

Do not share the Protective Earth Terminal \oplus with a welder or any other power equipment.

Ground terminal

- Applicable crimp terminal:
Round crimp terminal with insulation cover
- Thread size of terminal: M4
- Tightening torque: 1.2 N·m (10.6 lb-in)
- Applicable lead wire: AWG18 to 14 (0.75 to 2.0 mm²)

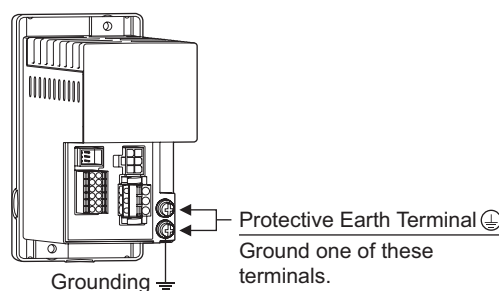

Precautions about static electricity

Static electricity may cause the driver to malfunction or suffer damaged.

Be sure to ground the motor and driver to prevent them from being damaged by static electricity.

5.4 Connecting the I/O signals

Connect the I/O signals to CN4 on the driver. Refer to p.16 for connection examples with a programmable controller.

Connecting the lead wire

Connect to insert the lead wire to the connector.

- Applicable lead wire: AWG24 to 18 (0.2 to 0.75 mm²)
- Length of the insulation cover which can be peeled: 10 mm (0.39 in.)

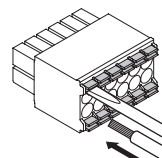

Crimp terminals can also be used to connect.

If crimp terminals are used, select the following terminals.

Manufacturer: PHOENIX CONTACT GmbH & Co. KG

- Model: AI 0,25-10 [Conductor cross-sectional area: 0.14 to 0.34 mm² (AWG24)]
 AI 0,34-10 [Conductor cross-sectional area: 0.14 to 0.34 mm² (AWG22)]
 AI 0,5-10 [Conductor cross-sectional area: 0.40 to 0.65 mm² (AWG20)]
 AI 0,75-10 [Conductor cross-sectional area: 0.65 to 0.82 mm² (AWG18)]

Connector model: DFMC1,5/6-ST-3,5 (PHOENIX CONTACT GmbH & Co. KG)

■ CN4 pin assignment

Pin No.	Signal name	Function*	Description
1	IN4	[ALARM-RESET]	This signal is used to reset the alarm.
2	IN3	[M1]	This signal is used to select the operation data.
3	IN2	[M0]	
4	IN1	[REV]	The motor rotates in the reverse direction while this signal is being "ON."
5	IN0	[FWD]	The motor rotates in the forward direction while this signal is being "ON."
6	IN-COM0	IN-COM0	Input signal common (For external power supply)
7	IN-COM1	IN-COM1	Input signal common (For internal power supply: 0 V)
8	N.C.	N.C.	Not connected.
9	OUT1-	[ALARM-OUT1]	This signal turns OFF when an alarm generates (normally closed).
10	OUT1+		
11	OUT0-	[SPEED-OUT]	30 pulses are output with each revolution of the motor output shaft.
12	OUT0+		

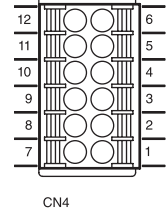

* The signal in brackets [] is a function that is assigned at the time of shipment. The assigned functions can be changed by setting parameters. Refer to p.27 for details.

■ Input signal circuit

All input signals of the driver are photocoupler inputs. Use these signals by the internal power supply (+5 VDC) or external power supply. When using the external power supply, both sink input logic and source input logic can be used by changing the wiring.

Usable external power supply: 24 VDC -15% to +20%, 100 mA or more

■ Output signal circuit

The driver outputs signals are photocoupler/open-collector output. The ON voltage of the output circuit is max. 1.5 V. When driving each element using the output signal circuit, give consideration to this ON voltage.

External power supply: 4.5 to 30 VDC, 100 mA or less (For the SPEED-OUT output, supply at least 5 mA of current.)

Note When connecting a relay (inductive load), etc., to detect alarm outputs, use a relay with built-in flywheel diode, or provide a fly-back voltage control measure based on diode, etc., for the inductive load.

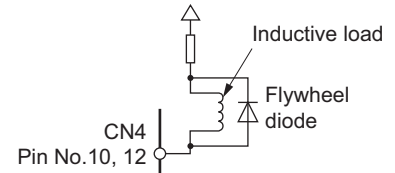

■ Using a external control equipment with a built-in clamp diode

If a external control equipment with a built-in clamp diode is used, a leakage path may form and cause the motor to operate even when the external control equipment power is off, as long as the driver power is on. Since the power capacity of the controller is different from that of the driver, the motor may operate when the external control equipment and driver powers are turned on or off simultaneously.

When powering down, turn off the driver power first, followed by the external control equipment power.

When powering up, turn on the external control equipment power first, followed by the driver power.

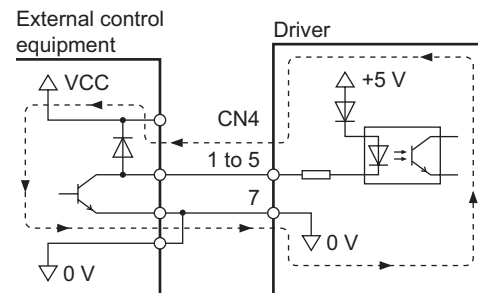

5.5 Connection example

■ Connection example for when using switches and relays

This is a connection example when the motor is operated using contact switches such as switches and relays.
(Single-phase 200-240 VAC)

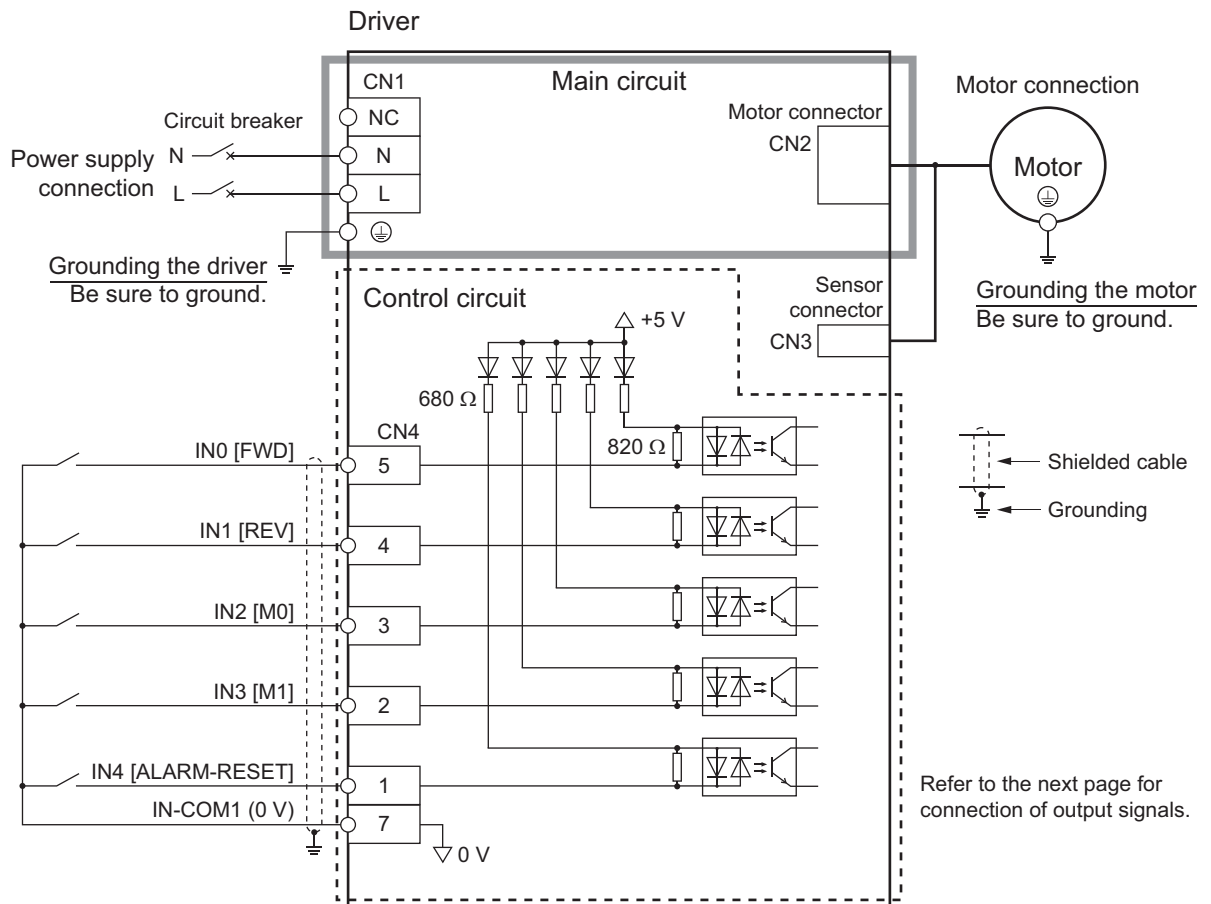

The I/O signal in the brackets [] is the assignment at the time of shipment.

Note Be sure to ground the motor and driver. Failure to do so may result in electric shock or damage to the product.
Static electricity may cause damage to the product if the Protective Earth Terminals are not grounded.

■ Connection example for I/O signals and programmable controller

This is a connection example when the motor is operated using a transistor output type programmable controller.

● Sink logic

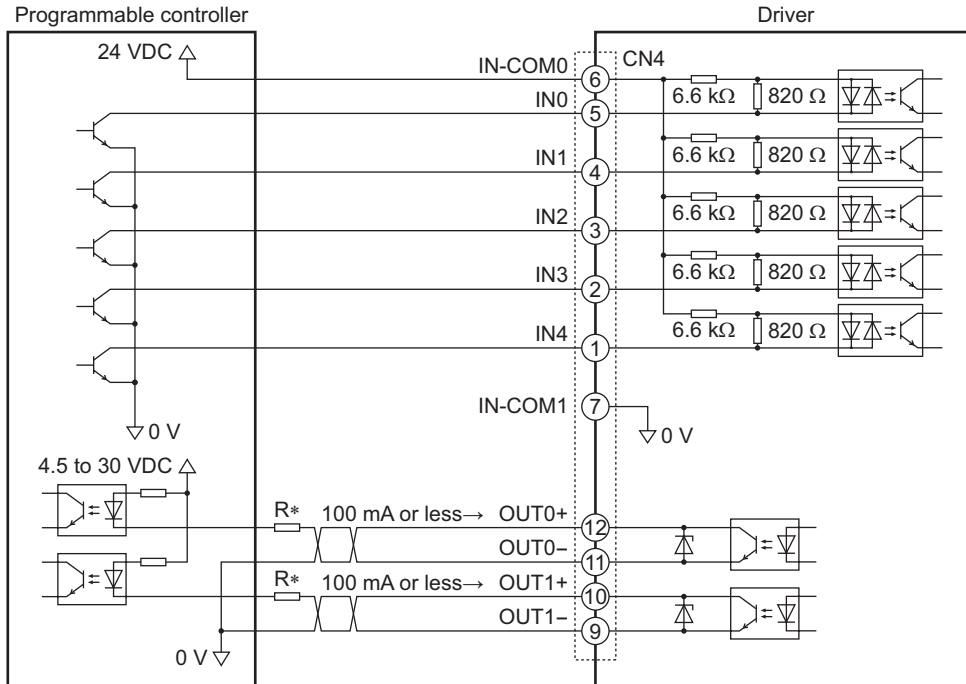

* Recommended resistance value for when the limiting resistor R is connected
 In the case of 24 VDC: 680 Ω to 2.7 kΩ (2 W)
 In the case of 5 VDC: 150 Ω to 560 Ω (0.5 W)

● Source logic

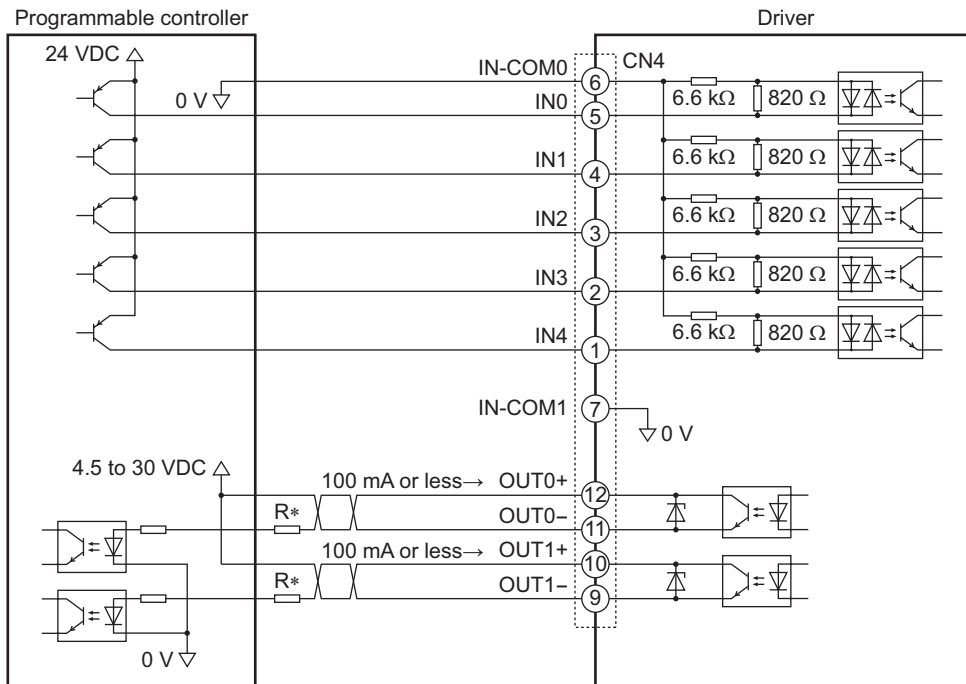

* Recommended resistance value for when the limiting resistor R is connected
 In the case of 24 VDC: 680 Ω to 2.7 kΩ (2 W)
 In the case of 5 VDC: 150 Ω to 560 Ω (0.5 W)

- Note**
- Use a power supply of 20.4 VDC to 28.8 VDC, 100 mA or more, for connecting input signals.
 - Turn ON the external power supply before turning ON the main power supply of the driver.
 - For the OUT0 and OUT1, be sure to keep the current value at 100 mA or less. If the current exceeds this value, connect the limiting resistor R.

6 Operating by front panel

This section explains how to operate the product with ease at the factory setting when receiving the product.

6.1 Connecting

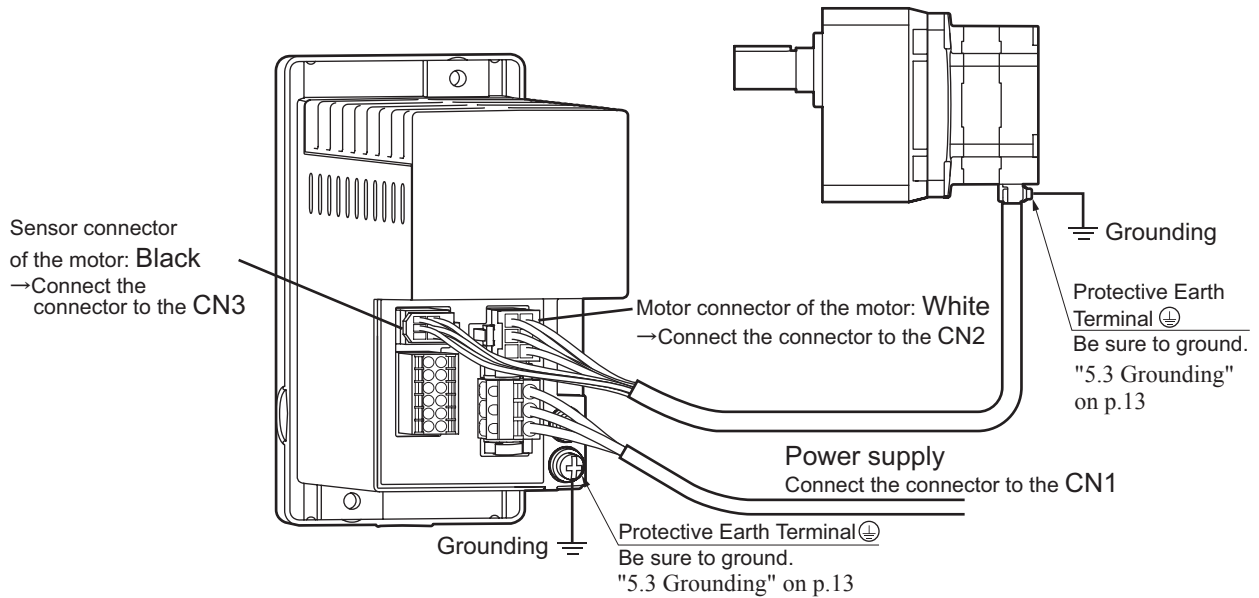

Connecting the power supply

Connect the AC power supply to the CN1 according to the input voltage. Refer to p.12 for the connecting the power supply.

Single-phase 200-240 V

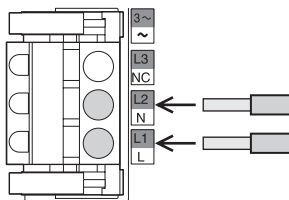

Three-phase 200-240 V

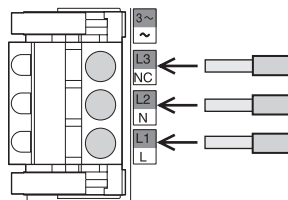

Connecting to the CN1

Strip the insulation cover of the lead wire

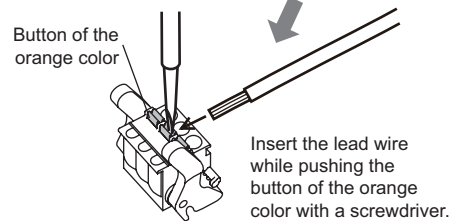

Note

- When cycling the power or plugging/unplugging the connector, turn off the power and wait for 1 minute or more before doing so.
- Ensure that the connector plugged in securely. Insecure connections may cause malfunction or damage to the product.

6.2 Inputting the power

Turn on the power after connecting as shown in the figure above.



Note

When inputting the power, if the operation switch is set to the RUN side, the alarm code "AL 46" (prevention of operation at power-on) is displayed, and the operation cannot be executed. Set the operation switch to the STAND-BY side and turn on the power.

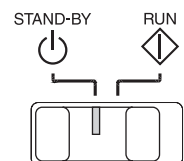

Operation switch

* Refer to p.33 for "prevention of operation at power-on" (alarm code: AL46).

Refer to the next page "6.3 Operating" for how to operate.

6.3 Operating

After turning on the power, operate the product as follows.

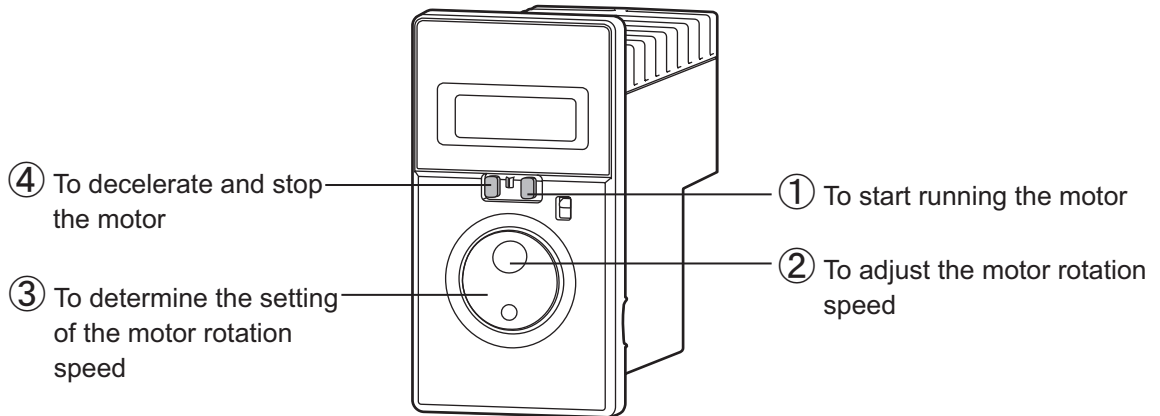

① Running the motor

Setting the operation switch to the RUN side causes the motor to start rotating.

② Adjusting the speed

When turning the setting dial to the right slowly, the rotation speed accelerates by 1 r/min increments. When turning the setting dial to the left slowly, the rotation speed decelerates by 1 r/min increments.

When turning the setting dial quickly, the amount of the rotation speed change increases.

③ Determining the speed

Set

When pressing the setting dial, the rotation speed is determined.

When the display is blinking, the rotation speed has not set yet. Determine it by pressing the setting dial. (The set data is saved in the operation data No.0. Refer to p.24 for details.)

Confirmation

If the setting dial is pressed while the motor stops, the set speed is displayed blinking (several times).

Operating with the setting dial can be limited by the lock function so that the set rotation speed cannot be changed. Refer to the p.31 "8.7 Data locking for the set data" for details.

④ Stopping the motor

Setting the operation switch to the STAND-BY side causes the motor to decelerate to a stop.

Setting the operation switch again to the RUN side causes the motor to start rotating at the set rotation speed.

[Changing the rotation direction]

Change the rotation direction of the motor (gearhead) using the rotation direction switch. The rotation direction can be changed while operating.

With the combination type, the rotation direction of the gearhead output shaft varies depending on the gear ratio of the gearhead. Refer to p.22 "7.3 Switching the motor rotation direction" for details.

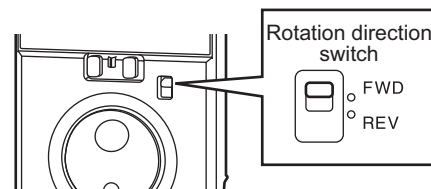

For switching the display or setting, refer to p.23 "8 Convenient functions."

7 Operating by programmable controller

The motor can be operated and stopped externally.

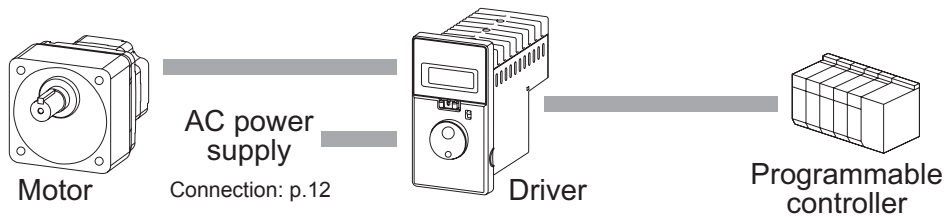

7.1 Operating

After connecting the operation input signals (FWD input, REV input) to the CN4, set and operate the product as follows.

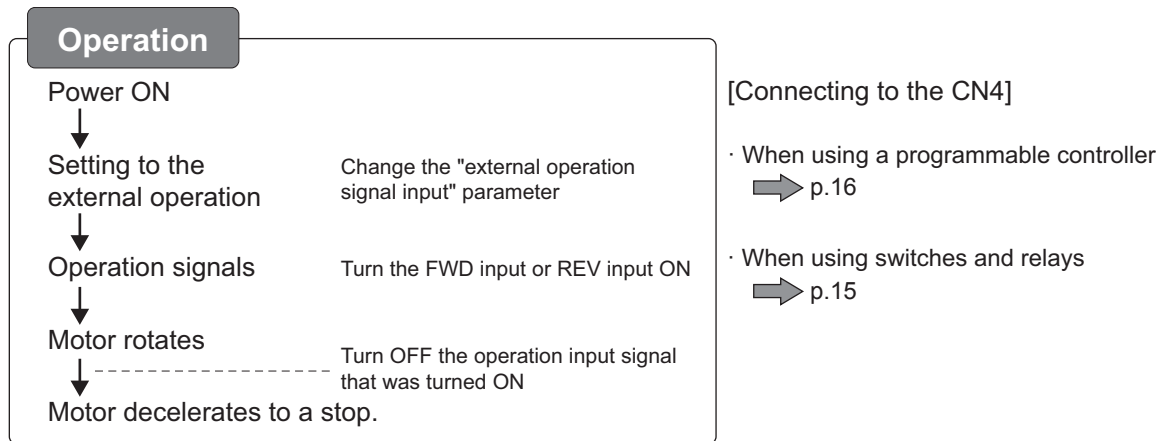

This operation example is for when the rotation speed is set to the operation data No.0.

■ Setting the "External operation signal input" parameter

The "external operation signal input" parameter (rEn) is required to change the setting when operating or stopping the motor externally.

The factory setting is "OFF" .

Setting range	OFF : Operation/standstill using front panel
	On : Operation/standstill using external signals (Front panel operation...Enable)
	rE : Operation/standstill using external signals (Front panel operation...Disable)

【Front panel operation】

Operation using the switches and setting dial on the front panel can be set to "Enable: ○" or "Disable: ×".

Setting	① Operation switch	② Rotation direction switch	③ Setting dial
On	○	○	○
rE	×	×	× *

* The data mode, parameter mode, and the I/O monitor of the monitor mode are enabled (possible to set).

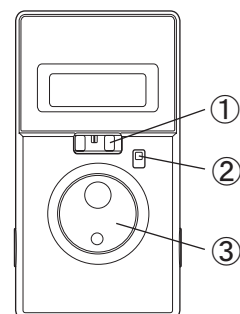

- When the setting is "ON"

Operation by switches on the front panel: Enable

When turning the operation input signal ON while the operation switch is set to the RUN side, the motor rotates.

When the operation switch is set to the "STAND-BY" side, the motor decelerates to a stop even if the operation input signal is being ON.

Turning the setting dial changes the motor rotation speed.

If the rotation direction switch is changed, the motor rotates in the opposite direction.

- When the setting is "RE"

Operation by switches on the front panel: Disable

If the operation switch or rotation direction switch are operated while setting to "RE," "rE" will be displayed.

Also, if the setting dial is operated while displaying the rotation speed, alarm, or warning in the monitor mode, "rE" will be displayed.

The data mode, parameter mode, and the I/O monitor of the monitor mode are enabled (possible to set).

The display time of "rE" varies depending on the switch.

- When setting the operation switch to the "RUN" side, "rE" will be displayed continuously.

- When switching the rotation direction switch to "FWD" (or "REV"), or when operating the setting dial, "rE" will be displayed for two seconds.

■ Example of timing chart

This is an example for when the "external operation signal input" parameter is set to "ON" and the rotation direction switch is set to the "FWD" side.

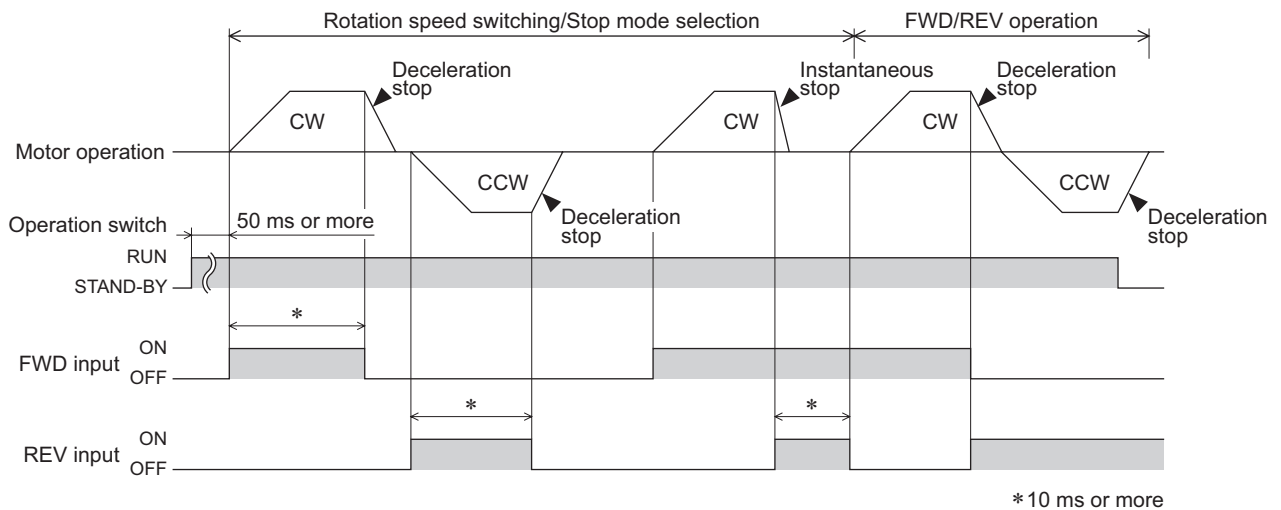

[Operation input signal]

- The motor rotates when either of the FWD input or REV input is turned ON.
- If the FWD input and REV input are turned ON simultaneously, the motor stops instantaneously.

7.2 Operating with multiple speeds

The operation at a speed of two or more can be performed by switching the external input.

■ Data setting method [Example: Set the rotation speed to 3000 r/min (change from 50 r/min)]

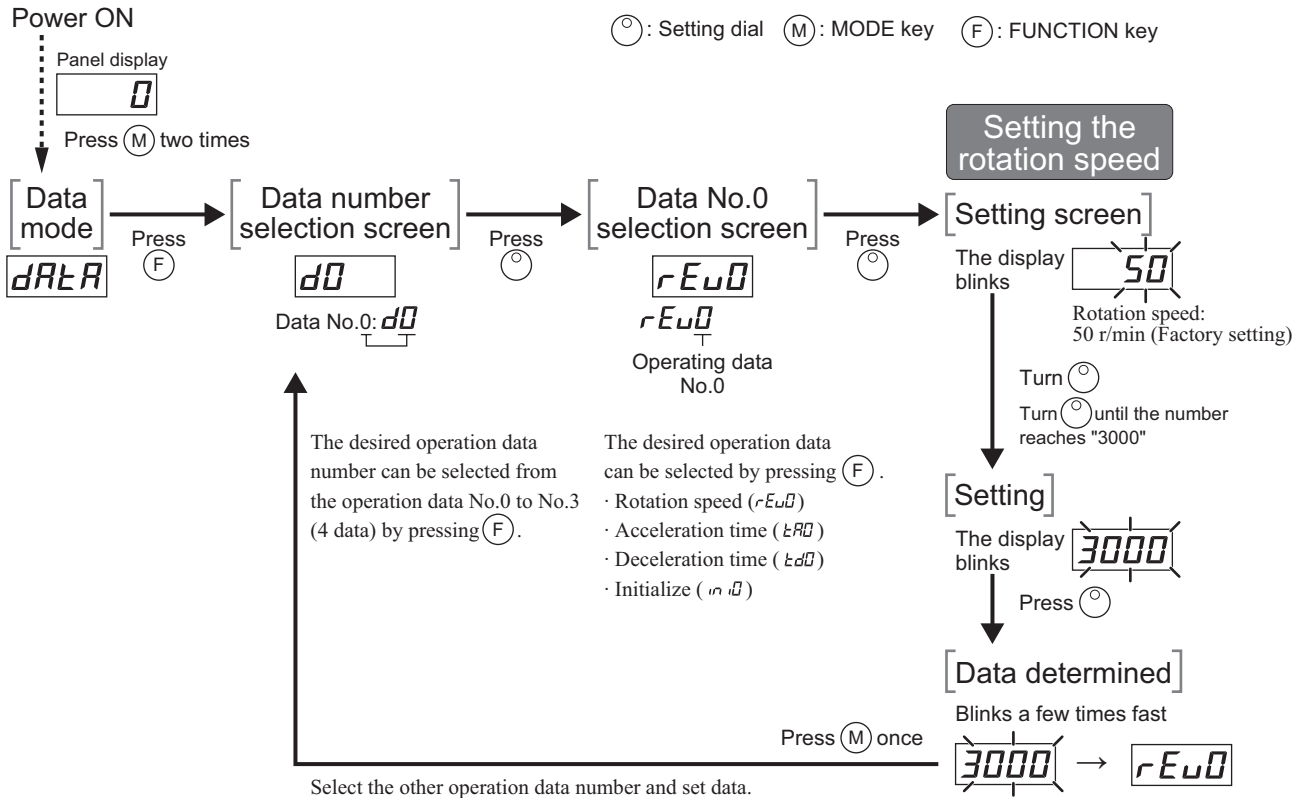

For the screen transitions, refer to p.24 "Setting items and panel displays."

■ Operating method

Operate the motor by selecting any of the operation data No.0 to No.3 based on a combination of ON/OFF status of the M0 and M1 inputs.

The motor is operated using the rotation speed, acceleration time, and deceleration time in the selected operation data number. The acceleration time and deceleration time at the factory setting have been set by the acceleration/deceleration time potentiometer.

[Operation procedure] (Example: When the "external operation signal input" parameter is set to "ON")

1. Set the operation switch to the "RUN" side.
2. Select the operation data number using the M0 and M1 inputs.
3. When either of the FWD input or REV input is turned ON, the motor will rotate.
4. Switch the operation data number using the M0 and M1 inputs.
5. When the FWD input or REV input which has been turned ON is turned OFF, the motor will stop.

• Example of operating condition

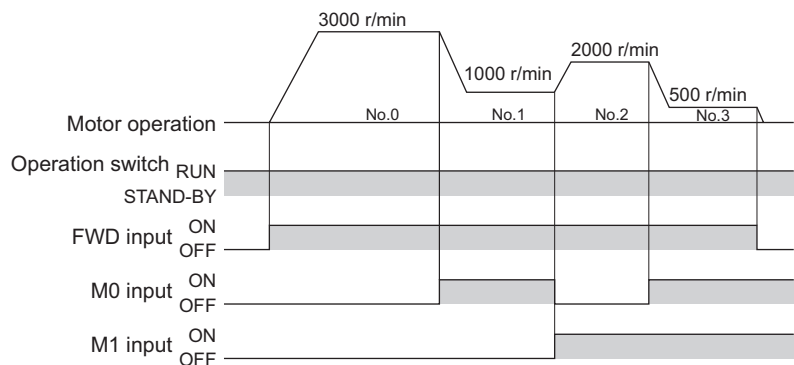

Operation data No.	M0	M1	Rotation speed [r/min]
0	OFF	OFF	3000
1	ON	OFF	1000
2	OFF	ON	2000
3	ON	ON	500

When changing from the present speed to the new speed, the acceleration time and deceleration time set in the next operation data number are used.

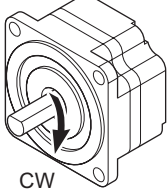
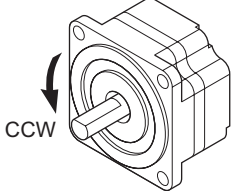

7.3 Switching the motor rotation direction

When turning the FWD input or REV input ON, the motor rotation direction varies depending on the state of the rotation direction switch. The rotation direction shown in the figure below is as viewed from the motor output shaft.

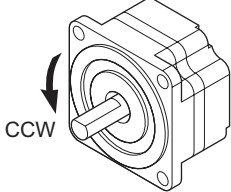
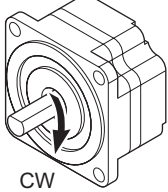
Rotation direction switch	External operation input	
	FWD input	REV input
<p>"FWD" side</p> 	<p>Motor rotation direction: <u>Clockwise</u></p> 	<p>Motor rotation direction: <u>Counterclockwise</u></p> 
<p>"REV" side</p> 	<p>Motor rotation direction: <u>Counterclockwise</u></p> 	<p>Motor rotation direction: <u>Clockwise</u></p> 

If the rotation direction switch is changed, the motor will decelerate to a stop and start rotating in the direction being switched.

If the "external operation signal input" parameter is set to "RE," the rotation direction switch will be disabled. The rotation direction at which "RE" was set is the same direction as the "FWD" side in the figure above.

Combination type • parallel shaft gearhead

The rotation direction of the motor output shaft may vary from that of the gearhead output shaft depending on the gear ratio of the gearhead.

Gear ratio	Rotation direction of gearhead output shaft
5, 10, 15, 20, 100, 200	Same as the motor output shaft
30, 50	Opposite to the motor output shaft

For switching the display or setting, refer to p.23 "8 Convenient functions."

8 Convenient functions

8.1 Functions list

The following functions are available for this product.

	Functions	Description	Reference page
Display	Rotation speed	Displays the rotation speed of the motor output shaft.	28, 26
		Displays by converting the motor rotation speed into the rotation speed of the gearhead output shaft.	
	Conveyor transfer speed	Displays by converting the motor rotation speed into the transfer speed of the conveyor drive.	29, 26
	Speed increasing	Displays by converting the motor rotation speed into the increasing speed.	
	Load factor	Displays the load torque applied on the motor output shaft as a percentage (%).	28
	Operation data No.	Displays the operation data number that is presently operating.	
	Alarm	Displays the alarm information by the alarm code.	28, 33
		Displays the alarm records.	
Warning	Displays the warning information by the warning code.	28, 35	
	Displays the warning records.		
I/O signals	Checks whether a signal is input.	28	
	Checks whether a signal is output.		
Setting	Rotation speed	Sets the motor rotation speed using the setting dial.	18
		Sets the motor rotation speed in the operation data.	29
	Acceleration time, deceleration time	Sets using the acceleration/deceleration time potentiometer.	30
		Sets in the operation data.	29
	Lock function	Disables an operation with the setting dial so that the set data cannot be changed.	31
	Operation using programmable controller	Operates by inputting signals externally.	19
		Disables an operation with the setting dial on the front panel.	
		Operates with multiple speeds. (Up to 4 speeds)	21
	Limiting the setting range of the rotation speed	Sets the upper limit and lower limit of the rotation speed.	31
	Slight position-keeping	The load position can be kept at motor standstill.	32
	Changing the function for I/O signals	Changes the functions assigned to the input signals (5 input signals).	27
		Changes the functions assigned to the output signals (2 output signals).	
	Initial display at power ON	Changes the display item when turning on the power.	26
	Data initialization	Restores the operation data to the factory setting (initial value).	29
Restores the parameter setting to the factory setting (initial value).		26	

8.2 Setting items and panel displays

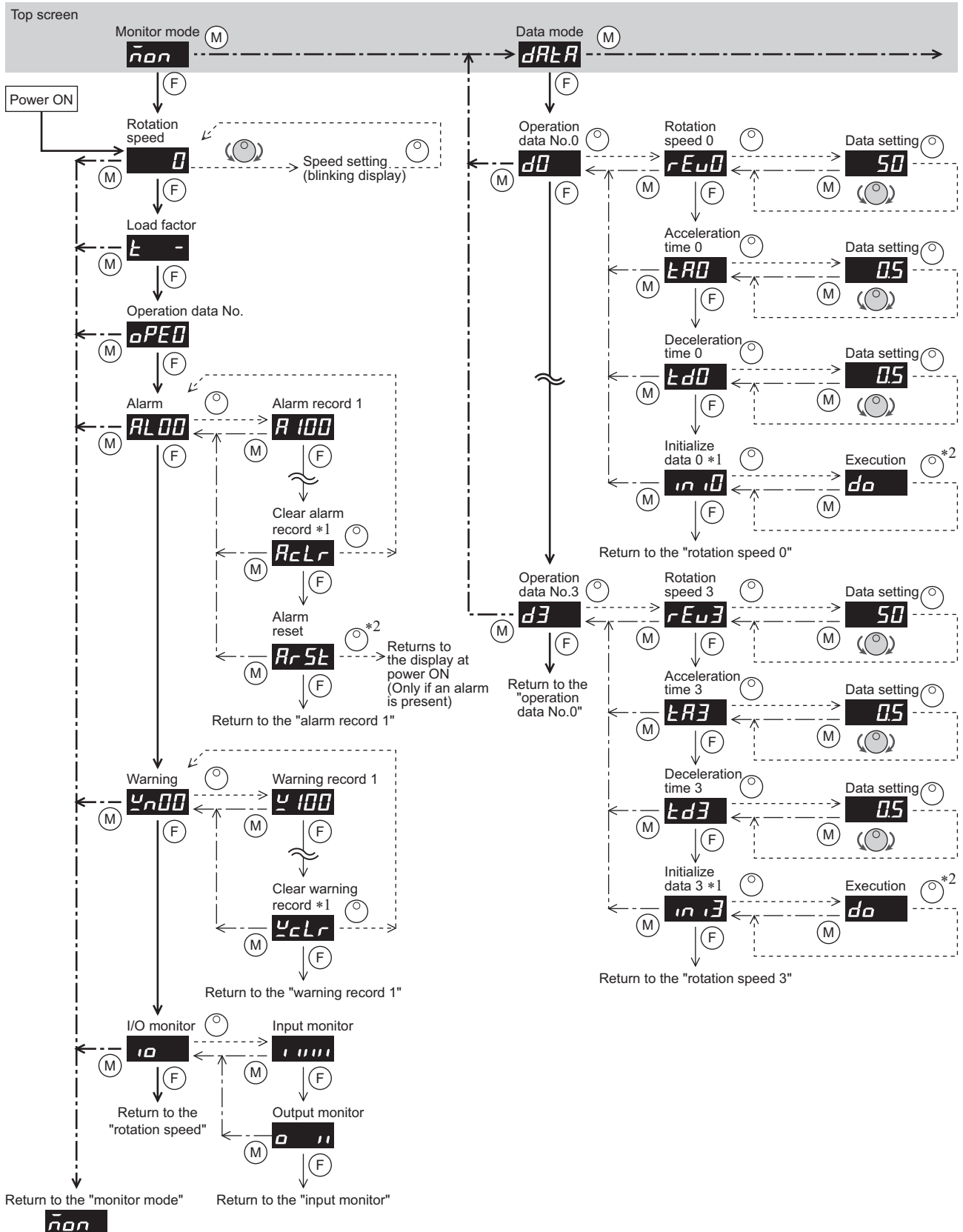

The display for when turning on the power can be changed using the "panel initial view" parameter.

When the front panel is removed

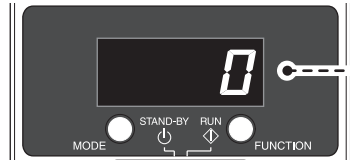

The characters on the black screen represents the indication on the display.

Explanation of graphic symbols

- : Turn the setting dial
- : Press the MODE key
- : Press the setting dial
- : Press the FUNCTION key

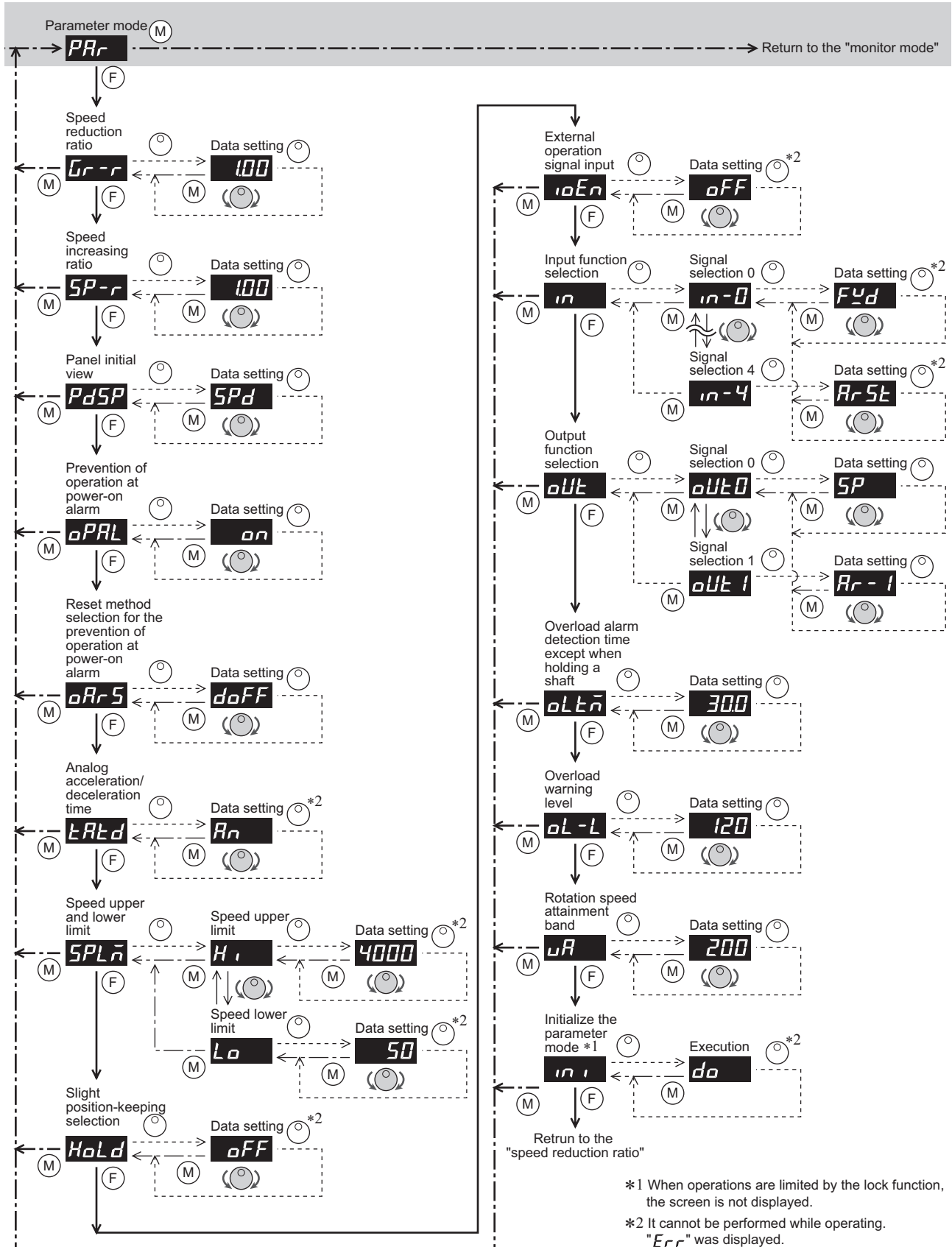

8.3 Parameter list

Operation mode: Parameter mode

Item	Display	Description	Setting range	Factory setting
Speed reduction ratio	<i>Gr-r</i>	Sets the speed reduction ratio relative to the rotation speed of the motor output shaft. Displays the speed calculated based on the speed reduction ratio on the monitor mode. If the speed reduction ratio for the conveyor is calculated and input, the conveyor transfer speed can also be displayed.	1.00 to 9999	1.00
Speed increasing ratio	<i>SP-r</i>	When increasing the motor rotation speed using the external mechanism and others, the converted speed can be displayed.	1.00 to 2.00	1.00
Panel initial view	<i>PdSP</i>	After the power is turned on, the item displayed on the monitor mode can be changed.	<i>SPd</i> Rotation speed (r/min) <i>Gr%</i> Load factor (%) <i>d-no</i> Operation data No.	<i>SPd</i>
Prevention of operation at power-on alarm	<i>oPRL</i>	Sets whether to enable or disable the "prevention of operation at power-on alarm."	<i>oFF</i> Disable <i>on</i> Enable	<i>on</i>
Reset method selection for the prevention of operation at power-on alarm	<i>oArS</i>	Selects how to reset the prevention of operation at power-on alarm.	<i>doFF</i> Resets by turning the FWD input or REV input OFF, or by setting the operation switch to the STAND-BY side. <i>ArSt</i> Resets using the ALARMRESET input or the alarm reset on the monitor mode.	<i>doFF</i>
Analog acceleration/ deceleration time	<i>tRtd</i>	Changes the setting method of acceleration/deceleration time.	<i>Rn</i> Sets using the acceleration/ deceleration time potentiometer. (analog) <i>dIG</i> Sets using the operation data. (digital)	<i>Rn</i>
Speed upper and lower limit	Speed upper limit <i>SPL\bar{n}</i>	<i>Hl</i> Sets the upper limit of the rotation speed.	50 to 4000	4000
	Speed lower limit	<i>Lo</i> Sets the lower limit of the rotation speed.		50
Slight position-keeping selection	<i>HoLd</i>	The load position can be kept at motor standstill.	<i>oFF</i> Disable <i>on</i> Enable	<i>oFF</i>
External operation signal input	<i>ioEn</i>	The operation method can be selected between the front panel and external input signals. When operating or stopping the motor using the external input signals, the functions of the operation switch, rotation direction switch, and setting dial can be set to disable.	<i>oFF</i> Operation/standstill using front panel <i>on</i> Operation/standstill using external signals (Front panel operation: Enable) <i>rE</i> Operation/standstill using external signals (Front panel operation: Disable)	<i>oFF</i>
IN0 input function selection	<i>in-0</i>	Assigns the input signals to the external input terminals.	<i>----</i> Not used	<i>FYd</i>
IN1 input function selection	<i>in-1</i>		<i>FYd</i> FWD <i>rEu</i> REV	<i>rEu</i>
IN2 input function selection	<i>in-2</i>		<i>n0</i> M0 <i>n1</i> M1	<i>n0</i>
IN3 input function selection	<i>in-3</i>		<i>ArSt</i> ALARM-RESET <i>E-Er</i> EXT-ERROR	<i>n1</i>
IN4 input function selection	<i>in-4</i>		<i>H-Fr</i> H-FREE	<i>ArSt</i>

Item	Display	Description	Setting range	Factory setting
OUT0 output function selection	<i>OUT0</i>	Assigns the output signals to the external output terminals.	---- Not used <i>AL-1</i> ALARM-OUT1 <i>SP</i> SPEED-OUT	<i>SP</i>
OUT1 output function selection	<i>OUT1</i>		<i>AL-2</i> ALARM-OUT2 <i>MOVE</i> MOVE <i>VA</i> VA <i>WNG</i> WNG	<i>AL-1</i>
Overload alarm detection time except when holding a shaft	<i>OLEN</i>	Sets the time to output the alarm after detecting the overload condition when a load up to the limited duty region exceeding the continuous duty region was applied.	0.1 to 60.0 s	30.0
Overload warning level	<i>OL-L</i>	Sets the detection level (load factor) for the overload warning function based on the rated current being 100%.	50 to 120%	120
Rotation speed attainment band	<i>UR</i>	Sets the band within which the rotation speed of the motor is deemed to have reached the set value.	0 to 400 r/min	200
Initialize the parameter mode	<i>INI</i>	Restores the value set in the parameter mode to the factory setting.	-	-

- Note**
- Do not turn off the motor power while the initialization is still in progress (= while the display is blinking). Doing so may damage the data.
 - When setting the speed increasing ratio to 1.00, the speed reduction ratio will be effective. When setting the speed increasing ratio to other than 1.00, the speed increasing ratio will be effective.
 - When setting a longer time in the "overload alarm detection time except when holding a shaft" parameter, an overload status may continue. Repeating this condition may result in shorter service life of the motor and gearhead.
 - If a load exceeding the limited duty region was applied or the output shaft was locked, the "overload alarm detection time except when holding a shaft" is maximum 5 seconds.

■ Description of I/O signals

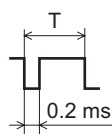
Signal	Terminal	Signal name	Description
Input	IN0 IN1 IN2 IN3 IN4	FWD	The motor rotates when either of the FWD input or REV input is turned ON. If the FWD input and REV input are turned ON simultaneously, the motor stops instantaneously.
		REV	
		M0	These signals are used to select the operation data number. If both signals are turned OFF, the operation data No.0 is selected.
		M1	
		ALARM-RESET	This signal is used to reset the alarm. Refer to p.34 for timing chart.
		EXT-ERROR	When turning this signal OFF, an alarm generates and the motor stops instantaneously. Then " <i>ALSE</i> " will be shown on the display (normally closed).
		H-FREE	The slight position-keeping is released when the H-FREE input is turned ON. (When the slight position-keeping selection is set to "Enable")
Output	OUT0 OUT1	ALARM-OUT1	This signal is output when an alarm generates (normally closed).
		SPEED-OUT	30 pulses are output with each revolution of the motor output shaft synchronously with the motor operation. The pulse width of output pulse signals is 0.2 ms. You can use the SPEED-OUT output to calculate the motor speed. $\text{SPEED-OUT output frequency (Hz)} = \frac{1}{T}$ $\text{Rotation speed (r/min)} = \frac{\text{SPEED-OUT output frequency}}{30} \times 60$ 
		ALARM-OUT2	This signal is output when exceeding the overload warning level. Or this signal is output when an overload alarm generates (normally closed).
		MOVE	This signal is output while the motor is operating.
		VA	This signal is output when the motor rotation speed becomes equal the value set by the rotation speed attainment band parameter.
		WNG	This signal is output when a warning generates. (The motor will continue to operate.) When the warning is released, it will automatically turn OFF.

- Note**
- Do not assign the same input signal to multiple input terminals. When the same input signal is assigned to multiple input terminals, the function will be executed if any of the terminals becomes active.

8.4 Items displayed on the driver

Operation mode: Monitor mode

Item	Display	Description
Rotation speed*		<ul style="list-style-type: none"> Monitors the rotation speed of the motor. Monitors the rotation speed of the gear output shaft or conveyor transfer speed when the "speed reduction ratio" parameter is set. When the "speed increasing ratio" parameter is set, the rotation speed being increased by the external mechanism is displayed.
Load factor		<p>The motor generating torque can be checked. The present load factor is displayed based on the rated torque being 100%. The load factor is displayed in 1% increment between 40% and 200%, and "L -" is displayed if the load factor is smaller than 40%.</p> <p>The display is the load factor on the motor output shaft. It is not for the gearhead output shaft.</p> <p>With the combination type product, the permissible torque varies depending on the gear ratio of the gearhead.</p> <p>Use the product so that the load does not exceed the permissible torque of the gearhead output shaft.</p> <p>When the slight position-keeping is enabled, "L H" is displayed.</p>
Operation data No.		Monitors the operation data No. currently selected.
Alarm		When an alarm generates, the alarm code is displayed. You can also reset alarms or check and clear alarm records. Refer to p.33 for alarm type.
Warning		When a warning generates, the warning code is displayed. You can also check and clear warning records. Refer to p.35 for warning type.
I/O monitor		<p>You can check the ON/OFF status of each I/O signal of the driver. If the signal is ON, the corresponding digit is lit. If the signal is OFF, the digit is unlit.</p>

* For the factory setting, the rotation speed is displayed when the power is turned on.
The display for when turning on the power can be changed using the parameter. "Panel initial view" parameter: p.26

■ Display of the rotation speed

- Displayed digit number when setting the speed reduction ratio or speed increasing ratio

Since the number of significant figures for the integer part is changed if the speed reduction ratio or speed increasing ratio is set, the digit number displayed on the panel will also be changed.

Setting value for the speed reduction ratio and speed increasing ratio	Display on the monitor mode
1.00 to 9.99	0 to 9999
10.00 to 99.99	0.0 to 999.9
100.0 to 999.9	0.00 to 99.99
1000 or more	0.000 to 9.999

• Display the conveyor transfer speed

To display the conveyor transfer speed, calculate the conveyor speed reduction ratio by using the formula below and set to the "speed reduction ratio" parameter.

$$\text{Conveyor speed reduction ratio} = \frac{1}{\text{Feed rate per motor revolution}} = \frac{\text{Gearhead gear ratio}}{\text{Pulley diameter [m]} \times \pi}$$

When the calculated conveyor speed reduction ratio is used, the conveyor transfer speed is converted as follows:

$$\text{Conveyor transfer speed [m/min]} = \frac{\text{Motor output shaft rotation speed [r/min]}}{\text{Conveyor speed reduction ratio}}$$

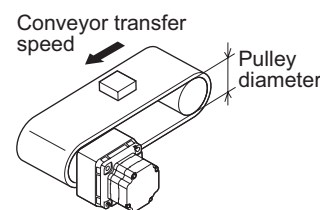

Example: The pulley diameter is 0.1 m and gear ratio of the gear head is 20

$$\text{Conveyor speed reduction ratio} = \frac{\text{Gearhead gear ratio}}{\text{Pulley diameter [m]} \times \pi} = \frac{20}{0.1 \text{ [m]} \times \pi} \cong 63.7$$

From the conversion formula, the conveyor speed reduction ratio is calculated as 63.7 in this example. If the speed reduction ratio is 63.7 and rotation speed of the motor is 1300 r/min, the conveyor transfer speed is converted as follows:

$$\text{Conveyor transfer speed [m/min]} = \frac{1300}{63.7} \cong 20.4$$

Accordingly, "20.4" is shown on the panel.

■ Display while an alarm generates

The alarm code is displayed while the alarm generates, and the screen can be changed to other screens by pressing the MODE key or FUNCTION key.

However, even if the screen moved from the alarm code screen to others, the alarm code display blinks so that the alarm state can be checked.

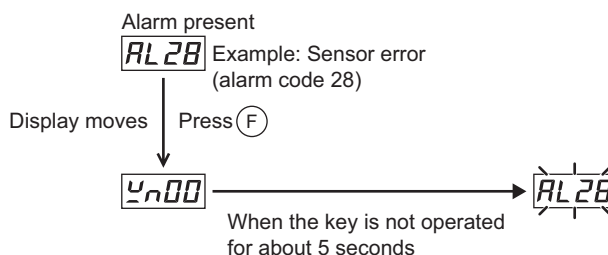

8.5 Setting the operation data

Four types of operation data can be set in this product. Operate by selecting the operation data number using the M0 and M1 input signals.

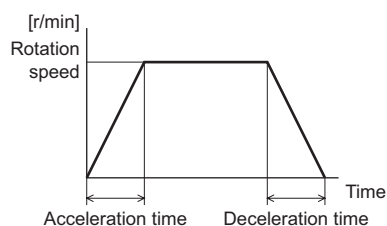

Operation mode: Data mode

Item	Display	Setting range	Factory setting	
Operation data No.0 No.1 No.2 No.3	Rotation speed	rE0	50 to 4000 r/min	50
	Acceleration time	tA	0.0 to 15.0 sec	0.5
	Deceleration time	tD		
	Initialize	r i	Restores the operation data to the factory setting. Initializes each operation data number.	

Refer to the next page for details about the acceleration time and deceleration time.

8.6 Setting the acceleration time and deceleration time

The acceleration time and deceleration time can be set so that an impact is not applied to a load when the motor is started or stopped.

There are the following two methods to set. The setting by the "acceleration/deceleration time potentiometer" is enabled at the time of shipment.

■ Setting using the acceleration/deceleration time potentiometer (Factory setting)

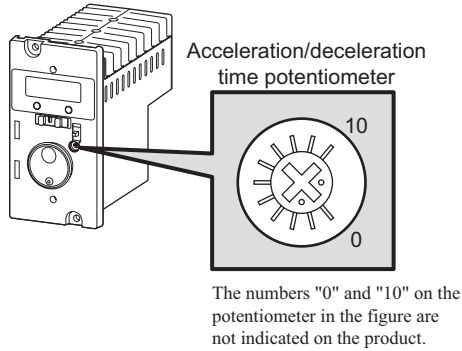

Acceleration/deceleration time potentiometer characteristics (representative values)

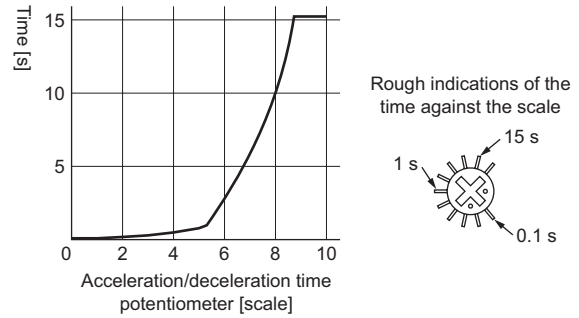

Setting range: 0.1 to 15.0 sec (factory setting: 0.1 sec)

- Acceleration time

The acceleration time is set as the time needed for the motor to reach the rated rotation speed (3000 r/min) from the standstill state.

- Deceleration time

The deceleration time is set as the time needed for the motor to stop from the rated rotation speed (3000 r/min).

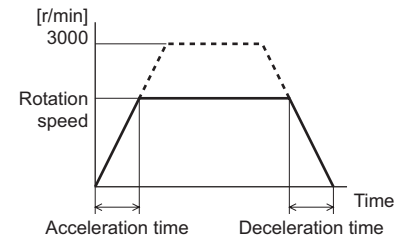

■ Setting to the operation data with digital setting

When setting by the acceleration time and deceleration time of the data mode, set the "analog acceleration/deceleration time" parameter of the parameter mode to the digital setting.

For the acceleration time and deceleration time in this digital setting, set the time needed to reach the set rotation speed.

Setting range: 0.0 to 15.0 sec (factory setting: 0.5 sec)

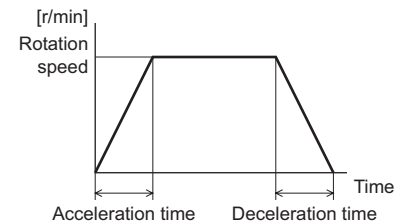

■ Motor operation

If the acceleration time and deceleration time are set shorter than 0.5 seconds, the motor takes for a longer time than 0.5 seconds to reach the speed.

If they are set to approximately 0.5 seconds or more, the motor can accelerate and decelerate in the setting time. (With no load)

When the frictional load or load inertia is increased, the operating time to reach the setting will be longer.

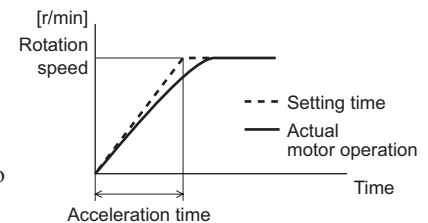

8.7 Data locking for the set data

The data setting can be locked so that the set rotation speed does not change.

The setting of data and parameters cannot be changed using the setting dial while locking.

Remove the front panel to set.

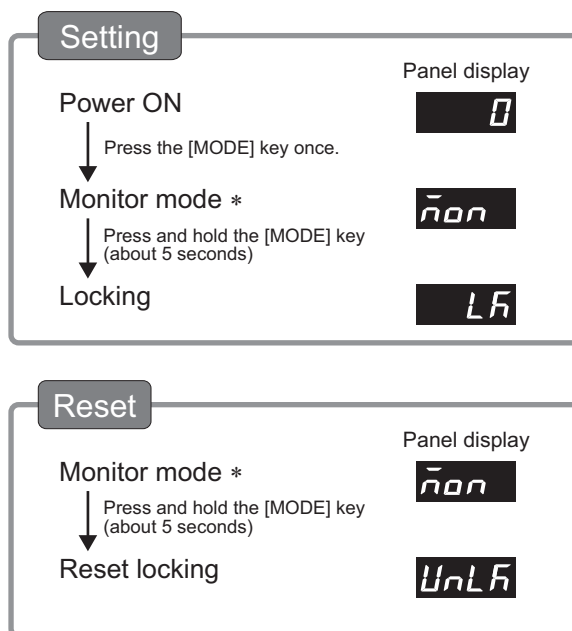
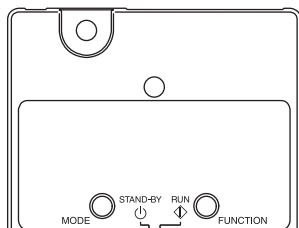

* Even when the top screen (*dALr, PRr*) of the data mode or parameter mode is displayed, the data locking or reset locking can be performed.

If the setting value of the operation data or parameter is tried to change, "Lr" is displayed for about one second.

8.8 Limiting the setting range of the rotation speed

The setting range of the rotation speed is set to 50 to 4000 r/min at the time of shipment. This setting range can be changed to limit.

Setting range of the rotation speed

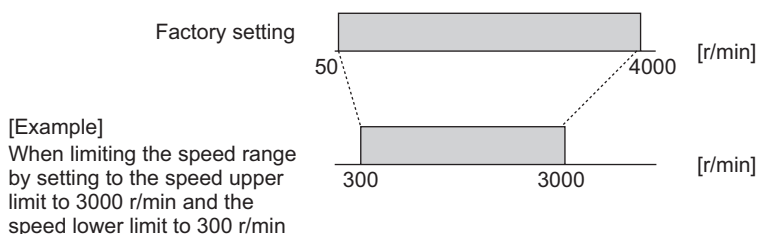

• Speed upper limit

Set the upper limit value of the rotation speed in the "speed upper limit" of the "speed upper and lower limit" parameter.

The rotation speed exceeding the "speed upper limit" cannot be set in the rotation speed of the operation data. If the rotation speed exceeding the "speed upper limit" is already set in the operation data, the rotation speed set in the "speed upper limit" will be overwritten.

• Speed lower limit

Set the lower limit value of the rotation speed in the "speed lower limit" of the "speed upper and lower limit" parameter.

The rotation speed lower than the "speed lower limit" cannot be set in the rotation speed of the operation data. If the rotation speed lower than the "speed lower limit" is already set in the operation data, the rotation speed set in the "speed lower limit" will be overwritten.

8.9 Holding a load at motor standstill

If the "slight position-keeping selection" parameter is set to ON (enable), the holding torque is somewhat generated when the motor stops (slight position-keeping torque).

The factory setting is OFF (disable). Refer to p.24 or p.26 for how to change the parameter.

- Up to 50% of the rated torque is generated according to the angle variation of the motor output shaft (figure).
The position of a load exceeding 50% of the rated torque cannot be kept.
- When the power supply to the driver is turned off, the holding torque is lost. This function cannot be used for keeping the load position in the event of a power outage.

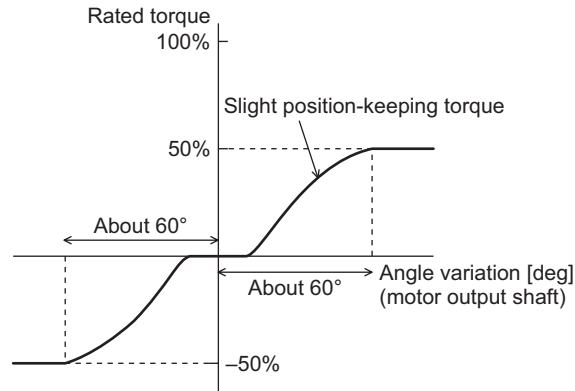

Slight position-keeping torque characteristic

9 Alarms and warnings

The driver provides alarms that are designed to protect the driver from overheating, poor connection, error in operation, etc. (protective functions), as well as warnings that are output before the corresponding alarms generate (warning functions).

9.1 Alarms

If a protective function is activated and an alarm is generated, the motor will coast to a stop, and then the holding power of the motor output shaft is lost. At the same time, the alarm code is displayed. The alarm type can be checked by the alarm code.

- Note**
- Cycle the power to reset the overcurrent and EEPROM error alarms. When cycling the power, turn off the power and wait for minimum 1 minute before doing so. If the product does not operate properly after the power is cycled, the internal circuit may be damaged. Contact your nearest Oriental Motor branch or sales office.
 - The motor stops instantaneously at the time of external stop "AL5E". After the motor is stopped, the holding power of the motor output shaft is lost.

■ Alarm list

Alarm code	Alarm type	Cause	Remedial action	Alarm reset *1
AL20	Overcurrent	Excessive current has flown through the driver due to ground fault, etc.	Check the wiring between the driver and motor for damage.	Not possible
AL21	Main circuit overheat	The temperature inside the driver exceeded the alarm detection temperature.	<ul style="list-style-type: none"> • Review the ambient temperature. • Review the ventilation condition in the enclosure. 	Possible
AL22	Overvoltage	<ul style="list-style-type: none"> • The power supply voltage exceeded approximately 120% of the rated voltage. • Vertical drive (gravitational operation) was performed or a load exceeding the permissible load inertia was driven. 	<ul style="list-style-type: none"> • Check the power supply voltage. • If this alarm occurs during operation, reduce the load or make the acceleration/deceleration time longer. 	
AL25	Undervoltage	The power supply voltage became lower than approximately 60% of the rated voltage.	<ul style="list-style-type: none"> • Check the power supply voltage. • Check the wiring of the power supply cable. 	
AL28	Sensor error	The motor sensor signal line experienced an open circuit during operation, or the motor sensor connector came off.	Check the wiring between the driver and motor.	
AL30	Overload	<ul style="list-style-type: none"> • A load exceeding the continuous duty region was applied to the motor for the time exceeded the value set in the "overload alarm detection time except when holding a shaft" parameter. Or the output shaft was locked.*2 • The motor was started running under the state that the motor temperature was low. 	<ul style="list-style-type: none"> • Reduce the load. • Review the operation pattern such as acceleration/deceleration time. • If the ambient temperature is low, perform a trial operation in a light load state. 	
AL31	Overspeed	The rotation speed of the motor output shaft exceeded approximately 4800 r/min.	<ul style="list-style-type: none"> • Reduce the load. • Review the operation pattern such as acceleration/deceleration time. 	Not possible
AL41	EEPROM error	<ul style="list-style-type: none"> • The stored data was damaged. • Data became no longer writable or readable. 	Initialize the parameters.	
AL42	Sensor error at power-on	The motor sensor signal line experienced an open circuit during operation, or the motor sensor connector came off when turning on the power.	Check the wiring between the driver and motor.	Possible
AL46	Prevention of operation at power-on *3	When the "external operation signal input" parameter was set to "OFF," while the operation switch was set to the "RUN" side, the power was turned on again.	Set the operation switch to the "STAND-BY" side from the "RUN" side.	
		When the "external operation signal input" parameter was set to "ON," while the FWD input or REV input was turned ON, the power was turned on again.	<ul style="list-style-type: none"> • Set the operation switch to the "STAND-BY" side from the "RUN" side. • Turn the FWD input or REV input from ON to OFF. 	
AL5E	External stop *4	The EXT-ERROR input turned OFF.	Check the EXT-ERROR input.	

*1 When using the alarm reset on the monitor mode or resetting the alarm by assigning the ALARM-RESET input to the input terminal.

*2 If a load exceeding the limited duty region was applied or the output shaft was locked, an alarm is generated in maximum 5 seconds. However, if the value of the "overload alarm detection time except when holding a shaft" parameter is set to 5 seconds or less, the overload alarm is generated in the time that was set.

*3 This alarm is output when the "prevention of operation at power-on alarm" parameter is set to "Enable."

*4 This alarm is output when the EXT-ERROR is assigned to input terminal.

■ Alarm reset

Always reset an alarm after ensuring safety by removing the cause of the alarm and turning the operation signal OFF.

[How to reset the alarm]

- Turn the ALARM-RESET input to ON and then OFF. (The alarm will be reset at the OFF edge of the input.)
- Perform an alarm reset with the monitor mode.
- Turn off the power, wait for at least 1 minute, and then cycle the power.

When an alarm is reset, "AL00" is displayed for two seconds, then "0" is displayed. (Except for cycling the power)

* The screen selected in the "panel initial view" parameter is displayed.

Note

- If the motor does not operate properly after the power is cycled, internal circuit damage is suspected. Please contact your nearest Oriental Motor branch or sales office.
- Continuing the operation without removing the cause of the problem may cause malfunction of the equipment.

• Reset using the ALARM-RESET input

Turn the operation signal OFF and then turn ALARM-RESET input ON (keep it ON for 10 msec or more). The ALARM-RESET input is disabled while the operation signal is being ON. The figure shows an example for which the operation signal is the FWD input.

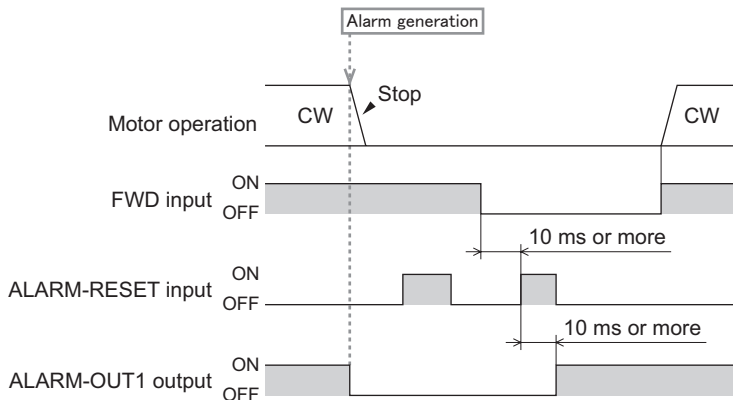

• Reset with the monitor mode

Set the operation switch to the "STAND-BY" side from the "RUN" side, and reset the alarm by the following steps.

Alarm present

AL28 Example: Sensor error
(alarm code 28)

Press

Alarm record 1

A128

Press

Clear alarm record

AcLr

Press

Alarm reset

ArSt

Press

AL00

Display for two seconds

Operation speed*

0

* The screen selected in the "panel initial view" parameter is displayed.

• When the present alarm is the prevention of operation at power-on alarm "AL45"

When operating the motor using the front panel, change the setting of the operation switch from the RUN side to the STAND-BY side.

When operating the motor using external input signals, the alarm will be reset by turning the operation signal OFF. This is the factory setting. The method to reset the alarm can be changed. Refer to p.24 or p.26 for details.

■ Alarm records

Up to 9 generated alarms are saved in the non-volatile memory in order of the latest to oldest.

When clearing the alarm records, perform the alarm record clear on the monitor mode.

Note

- Do not turn off the driver power while an alarm records are being cleared (=while the display is blinking). Doing so may damage the data.

9.2 Warnings

The warning types and records can be displayed on the monitor mode.

When a warning generates, the WNG output will be turned ON. The WNG output is not assigned to the output terminal at the time of shipment. Refer to p.27 "Description of I/O signals."

■ Warning list

Warning code	Warning type	Motor operation	Generation condition	Remedial action
$\underline{4n21}$	Main circuit overheat	Continue to operate	The temperature inside the driver exceeded the warning detection temperature.	<ul style="list-style-type: none"> • Review the ambient temperature. • Review the ventilation condition in the enclosure.
$\underline{4n30}$	Overload		A load exceeding the "overload warning level" parameter was applied to the motor.	Check the load condition.
$\underline{4n5c}$	Operation error	Stop	When the input terminal is ON, the operation signal was assigned using the "input function selection" parameter.	When assigning the operation signal, check that the input terminal to be assigned is turned OFF.

■ Warning records

Up to 9 generated warnings are saved in the RAM in order of the latest to oldest.

When clearing the warning records, perform the warning record clear on the monitor mode.

Note | The warning records will be cleared by turning off the driver power.

10 Troubleshooting and remedial actions

During motor operation, the motor or driver may fail to function properly due to an improper speed setting or wiring. When the motor cannot be operated correctly, refer to the contents provided in this section and take appropriate action. If the problem persists, contact your nearest office.

- Note**
- Check the alarm message when the alarm generates.
 - I/O signals can be monitored with the monitor mode. Use to check the wiring condition of the I/O signals.

The motor does not operate.	<ul style="list-style-type: none"> ● The power supply is not connected correctly or it has become improper connection. <ul style="list-style-type: none"> ▷ Check the connections between the driver and power supply.
	<ul style="list-style-type: none"> ● The operation switch is set to the "STAND-BY" side. <ul style="list-style-type: none"> ▷ Set the operation switch to the "RUN" side.
	<ul style="list-style-type: none"> ● When operating the motor using the operation switch, the "external operation signal input" parameter is set to "ON" or "RE." <ul style="list-style-type: none"> ▷ Set the "external operation signal input" parameter to "OFF" after setting the operation switch to the STAND-BY side.
	<ul style="list-style-type: none"> ● When operating the motor using external signals, the "external operation signal input" parameter is set to "OFF." <ul style="list-style-type: none"> ▷ Set the "external operation signal input" parameter to "ON" or "RE" after turning the input operation signal OFF.
	<ul style="list-style-type: none"> ● Both the FWD input and REV input are being OFF. ● Both the FWD input and REV input are being ON. <ul style="list-style-type: none"> ▷ Turn either of the FWD input or REV input ON.
	<ul style="list-style-type: none"> ● An alarm is present. <ul style="list-style-type: none"> ▷ A protective function is triggered and an alarm generates. Refer to p.33 and reset the alarm after removing the cause of the alarm.

The rotation speed is not displayed.	<ul style="list-style-type: none"> ● The "panel initial view" parameter is not set to the rotation speed. <ul style="list-style-type: none"> ▷ Set the "panel initial view" parameter to the rotation speed.
---	--

The motor rotates in the direction opposite to the specified direction.	<ul style="list-style-type: none"> ● The FWD input and REV input are connected wrongly or otherwise not connected correctly. <ul style="list-style-type: none"> ▷ Check the connection of the FWD input and REV input.
	<ul style="list-style-type: none"> ● A gearhead which gear ratio is 30:1 or 50:1 is used for the combination type product with a parallel shaft gearhead. <ul style="list-style-type: none"> ▷ When the gear ratio of the combination type • parallel shaft gearhead is 30:1 or 50:1, the rotation direction of the gear output shaft is opposite of the motor output shaft. Accordingly, reverse the FWD input and REV input operations.
	<ul style="list-style-type: none"> ● The rotation direction switch is set wrong. <ul style="list-style-type: none"> ▷ Check the rotation direction switch.
	<ul style="list-style-type: none"> ● When the rotation direction switch is set to REV, the "external operation signal input" parameter is set to "RE." <ul style="list-style-type: none"> ▷ Check the setting of the "external operation signal input" parameter.
The setting cannot be performed using the setting dial.	<ul style="list-style-type: none"> ● The lock function has been enabled. <ul style="list-style-type: none"> ▷ Release the lock function.
The motor is not reversed by the rotation direction switch.	<ul style="list-style-type: none"> ● The "external operation signal input" parameter is set to "RE." <ul style="list-style-type: none"> ▷ Check the setting of the "external operation signal input" parameter.
The rotation speed cannot be increased.	<ul style="list-style-type: none"> ● The speed upper limit has been set. <ul style="list-style-type: none"> ▷ Raise the speed upper limit.
The rotation speed cannot be decreased.	<ul style="list-style-type: none"> ● The speed lower limit has been set. <ul style="list-style-type: none"> ▷ Lower the speed lower limit.

Motor operation is unstable.	<ul style="list-style-type: none"> ● The motor (gearhead) output shaft is not misaligned with the load shaft. <ul style="list-style-type: none"> ▷ Check the coupling condition of the motor (gearhead) output shaft and load shaft.
	<ul style="list-style-type: none"> ● Effect of electrical noise. <ul style="list-style-type: none"> ▷ Check the operation only with the motor, driver and other external equipment required for operation. If an effect of noise has been confirmed, implement the following countermeasures: [Move the unit farther away from noise generation sources.] [Review the wiring.] [Change the signal cables to a shielded type.] [Install ferrite cores.]
Motor vibration is too great.	

11 Inspection

It is recommended that periodic inspections for the items listed below are conducted after each operation of the motor. If an abnormal condition is noted, discontinue any use and contact your nearest Oriental Motor sales office.

Note

- Do not conduct the insulation resistance measurement or dielectric strength test with the motor and driver connected. Conducting the insulation resistance measurement or dielectric strength test with the motor and driver connected may result in damage to the product.
- The driver uses semiconductor elements, so be extremely careful when handling them. Electrostatic discharge can damage the driver.

■ During inspection

- Are any of the motor (gearhead) mounting screws loose?
- Are there any abnormal noises in the motor bearings (ball bearings) or other moving parts?
- Are there any abnormal noises in the bearing (ball bearing) and gear meshing parts of the gearhead?
- Are the motor output shaft and load shaft out of alignment?
- Are there any scratches, signs of stress or loose driver connections in the cable?
- Are the openings in the driver blocked?
- Are any of the mounting screws or main power input unit of the driver loose?
- Are there any strange smells or appearances within the driver?

12 Accessories (sold separately)

■ Connection cable

This cable is used to extend the wiring distance between the driver and motor. The wiring distance between the motor and driver can be extended to a maximum of 10.5 m (34.4 ft.). Flexible connection cables are also available.

The motor cables, connection cables and flexible connection cables are shielded cables which have taken measures against the electrical noise.

The connection cable can be connected up to 2 pieces.

• Connection cable

Length [m (ft.)]	Model
1 (3.3)	CC01BL2
2 (6.6)	CC02BL2
3 (9.8)	CC03BL2
5 (16.4)	CC05BL2
7 (23.0)	CC07BL2
10 (32.8)	CC10BL2

• Flexible connection cable

Length [m (ft.)]	Model
1 (3.3)	CC01BL2R
2 (6.6)	CC02BL2R
3 (9.8)	CC03BL2R
5 (16.4)	CC05BL2R
7 (23.0)	CC07BL2R
10 (32.8)	CC10BL2R

Connector pin assignments of motor cable

The following tables are the connector pin assignments of the motor cable that comes out of the motor.

The following figure is as view from the direction of the motor lead wires side.

• Motor connector (White)

Pin No.	Color	Lead wire
1	Blue	AWG18
2	-	-
3	-	Drain AWG24 or equivalent
4	Purple	AWG18
5	Gray	
6	-	-

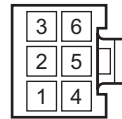

Housing: 5557-06R-210 (molex)
Terminal: 5556T (molex)

• Sensor connector (Black)

Pin No.	Color	Lead wire
A3	-	-
A2	Green	AWG26
A1	Yellow	
B3	Brown	
B2	Red	
B1	Orange	

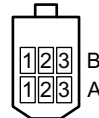

Housing: J11DF-06V-KY
(J.S.T. Mfg Co., Ltd.)
Terminal: SF1F-002GC-P0.6
(J.S.T. Mfg Co., Ltd.)

■ Power supply cable

This cable is used to connect the driver to the power supply.

• For single-phase 200-240 VAC

Length [m (ft.)]	Model
1 (3.3)	CC01AC03N
2 (6.6)	CC02AC03N
3 (9.8)	CC03AC03N

• For three-phase 200-240 VAC

Length [m (ft.)]	Model
1 (3.3)	CC01AC04N
2 (6.6)	CC02AC04N
3 (9.8)	CC03AC04N

These cables are not shielded cables. If conformance to the EMC Directive is required, refer to "13.2 Installing and wiring in compliance with EMC Directive"(p.40).

13 Reference

13.1 Standard and CE Marking

This product is recognized by UL. The CE Marking (Low Voltage Directive and EMC Directive) is affixed to the product in accordance with EN Standards.

The name of products certified to conform with relevant standards are represented by applicable unit model motor and driver part numbers.

■ UL Standards and CSA Standards

Applicable Standards

	Applicable Standards	Certification Body	Standards File No.
Motor *1	UL 1004-1 CSA C22.2 No.100	UL	E335369
Driver *2	UL 508C CSA C22.2 No.14		E171462

*1 Thermal class UL/CSA Standards: 105(A)

*2 The driver is recognized by UL under the condition that the front panel side of the driver is installed in the front direction. Installation direction → p.11

■ Low Voltage Directive

- This product is designed and manufactured to be incorporated in equipment.
- This product cannot be used in IT power distribution systems.
- Install the product within the enclosure in order to avoid contact with hands.
- Be sure to ground the Protective Earth Terminal of the motor and driver.
- Isolate the motor cable, power-supply cable and other drive cables from the signal cables (CN4) by means of double insulation.

Applicable Standards

- Motor: EN 60034-1, EN 60034-5, EN 60664-1
- Driver: EN 61800-5-1

Installation conditions (EN Standard)

Motor *	Driver
For incorporating in equipment Overvoltage category: II Pollution degree:2 (for IP40 rated motor) 3 (for IP65 rated motor) Protection against electric shock: Class I	For incorporating in equipment Overvoltage category: II Pollution degree: 2 Protection against electric shock: Class I

* Thermal class EN Standards: 120(E)

■ EMC Directive

This product has received EMC compliance under the conditions specified in "Example of motor and driver installation and wiring" on p.41. The final level of conformance of your mechanical equipment to the EMC Directive will vary depending on the control system equipment used with the motor/driver, configuration of electrical parts, wiring, layout, hazard level, and the like. It therefore must be verified through conducting EMC measures on your mechanical equipment.

This type of PDS is not intended to be used on a low-voltage public network which supplies domestic premises; radio frequency interference is expected if used on such a network.

Applicable Standards

EMI	EN 55011 group1 class A
	EN 61000-6-4, EN 61800-3
	EN 61000-3-2
	EN 61000-3-3
EMS	EN 61000-6-2, EN 61800-3

■ The motor temperature rise tests

A temperature test has been conducted with a heatsink plate.

The size, thickness and material of the heatsink plates are as table.

Motor model	Size [mm (in.)]	Thickness [mm (in.)]	Material
BLM6200	200×200 (7.87×7.87)	5 (0.20)	Aluminum alloy

■ Hazardous substances

The products do not contain the substances exceeding the restriction values of RoHS Directive (2011/65/EU).

■ Republic of Korea, Radio Waves Act.

한국전파법

Seller and user shall be noticed that this equipment is suitable for electromagnetic equipments for office work (Class A) and it can be used outside home.

이 기기는 업무용(A 급) 전자파적합기기로서 판매자 또는 사용자는 이 점을 주의하시기 바라며, 가정외의 지역에서 사용하는 것을 목적으로 합니다.

13.2 Installing and wiring in compliance with EMC Directive

This product has been designed and manufactured to be incorporated in equipment. The EMC Directive requires that your mechanical equipment in which the product is installed satisfies the applicable requirements.

The installation/wiring methods of the motor and driver explained here represent the basic methods that are effective in helping your mechanical equipment conform to the EMC Directive.

The final level of conformance of your mechanical equipment to the EMC Directive will vary depending on the control system equipment used with the motor, configuration of electrical parts, wiring, layout, hazard level, and the like. It therefore must be verified through conducting EMC measures on your mechanical equipment.

Without effective measures to suppress the electromagnetic interference (EMI) caused by the product in the surrounding control system equipment or the electromagnetic spectrum (EMS) generated by the product, the function of your mechanical equipment may be seriously affected.

This product will conform to the EMC Directive if installed/wired using the methods specified below.

■ Connecting a mains filter

Install a mains filter which the customer provides, in the power line in order to prevent the noise generated within the driver from propagating outside via the AC input line. For mains filters, use the products as shown in the chart, or an equivalent.

Manufacturer	Single-phase 200-240 V	Three-phase 200-240 V
SOSHIN ELECTRIC CO., LTD	HF2010A-UPF	NFU3010C-Z1
Schaffner EMC	FN2070-10-06	FN3025HP-10-71

- Overvoltage category II applies to mains filters.
- Install the mains filter as close to the driver as possible.
- Use cable clamps and other means to secure the input and output cables firmly to the surface of the enclosure.
- Connect the ground terminal of the mains filter to the grounding point, using as thick and short a wire as possible.
- Do not place the AC input cable (AWG18 to 14: 0.75 to 2.0 mm²) parallel with the mains-filter output cable (AWG18 to 14: 0.75 to 2.0 mm²). Parallel placement will reduce mains filter effectiveness if the enclosure's internal noise is directly coupled to the power supply cable by means of stray capacitance.

■ Connecting the AC power line reactor

When inputting single-phase 200-240 V, insert a reactor (5 A, 2 mH) in the AC power line to ensure compliance with EN 61000-3-2.

■ Connecting the external power supply

Use an external power supply conforming to the EMC Directive. Use a shielded cable for wiring the external power supply over the shortest possible distance. Refer to the next page "Wiring the power supply cable" for how to ground the shielded cable.

■ How to ground

The cable used to ground the motor, driver, mains filter and power supply cable (shielded cable) must be as thick and short to the grounding point as possible so that no potential difference is generated. Choose a large, thick and uniformly conductive surface for the grounding point. Refer to the p.13 for the recommended grounding method.

■ Wiring the power supply cable

Use a shielded cable of AWG18 to 14 (0.75 to 2.0 mm²) in diameter for the driver power supply cable and keep it as short as possible. Strip a part of the shielded cable and ground the stripped part using a metal cable clamp that contacts the stripped cable around its entire circumference, or use a drain wire to make the ground connection.

When grounding the shielded cable, connect both ends (mains filter side and power supply side) to earth to prevent a potential difference from generating in the shielded cable.

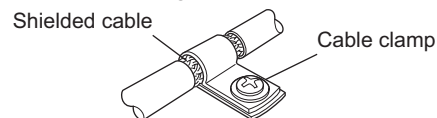

■ Notes about installation and wiring

- Connect the motor/driver and other peripheral control equipment directly to the grounding point so as to prevent a potential difference from developing between grounds.
- When relays or electromagnetic switches are used together with the system, use mains filters and CR circuits to suppress surges generated by them.
- Keep cables as short as possible without coiling and bundling extra lengths.
- Wire the power lines such as the motor cable and power cable away from the signal cables by providing a minimum clearance of 100 mm (3.94 in.) between them. If they must cross, do so at a right angle. Place the AC input cable and output cable of a mains filter separately from each other.
- Use a connection cable (supplied or accessory) when extending the wiring distance between the motor and driver. The EMC measures are conducted using the Oriental Motor connection cable.

■ Example of motor and driver installation and wiring

When the product is of single-phase input power

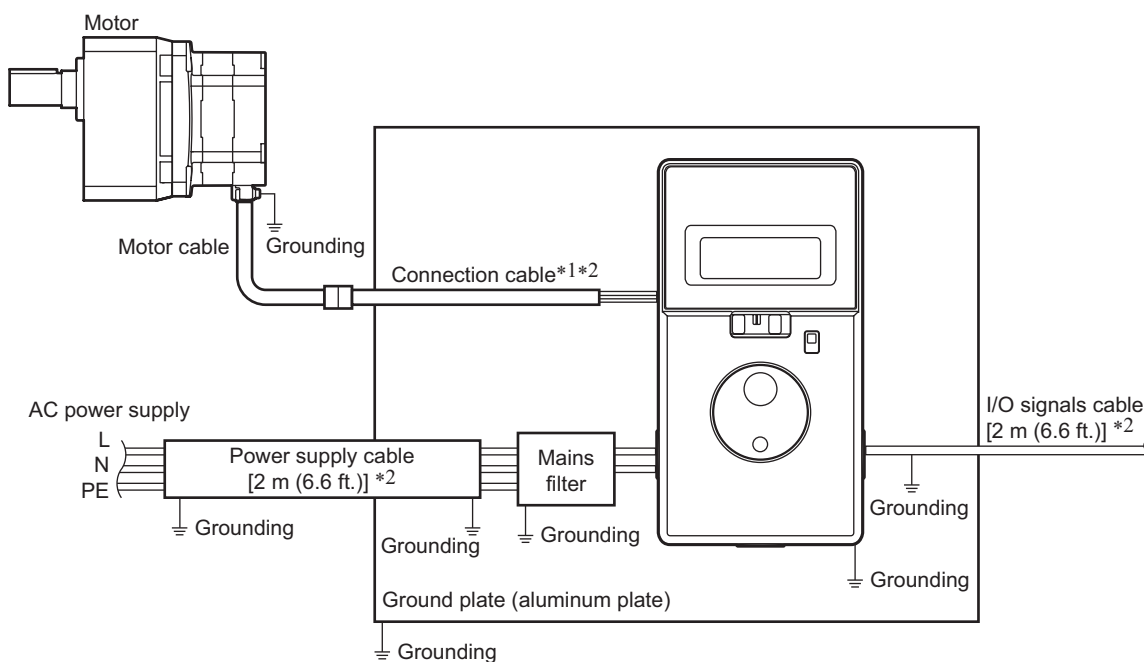

*1 Performance has been evaluated based on connection cable lengths of up to 10 m (32.8 ft.). The connection cable can be connected up to 2 pieces.

*2 Shielded cable

■ Precautions about static electricity

Static electricity may cause the driver to malfunction or suffer damaged.

Be sure to ground the motor and driver to prevent them from being damaged by static electricity.

Except when operating the setting dial, potentiometer or switches on the driver front panel, do not come to close or touch the driver while the driver power is ON. To change the settings of driver acceleration/deceleration time potentiometer, be sure to use an insulated screwdriver.

13.3 Specifications

- □ in the model names indicates a number representing the gear ratio.
- ■ indicates the cable length (-3) when the connection cable is supplied.

Model	Combination type • parallel shaft gearhead	BMU6200SC-□A■* BMU6200SCP-□A■*
Rated output power (Continuous)		200 W
Power supply input	Rated voltage	Single-phase 200-240 V Three-phase 200-240 V
	Permissible voltage range	-15 to +10%
	Rated frequency	50/60 Hz
	Permissible frequency range	±5%
	Rated input current	Single-phase: 2.7 A Three-phase: 1.5 A
	Maximum input current	Single-phase: 4.9 A Three-phase: 3.4 A
Rated torque		0.637 N·m (90 oz-in)
Instantaneous peak torque		1.15 N·m (163 oz-in)
Rated rotation speed		3000 r/min
Speed control range		80 to 4000 r/min

* The value in a state where the gearhead is not combined is described in each specification for the "rated torque," "instantaneous peak torque," "rated rotation speed" and "speed control range."

General specifications

Operation environment	Ambient temperature	Motor: 0 to +40 °C [+32 to +104 °F] (non-freezing) Driver: 0 to +40 °C [+32 to +104 °F] (non-freezing)
	Ambient Humidity	85% or less (non-condensing)
	Altitude	Up to 1000 m (3300 ft.) above sea level
	Surrounding atmosphere	No corrosive gas or dust. Cannot be used in radioactive materials, magnetic field, vacuum or other special environment. Details about the installation location are described on p.8.
	Vibration	Not subject to continuous vibrations or excessive impact In conformance with JIS C 60068-2-6 "Sine-wave vibration test method" Frequency range: 10 to 55 Hz, Pulsating amplitude: 0.15 mm (0.006 in.) Sweep direction: 3 directions (X, Y, Z), Number of sweeps: 20 times
Storage environment	Ambient temperature	Motor: -20 to +70 °C [-4 to +158 °F] (non-freezing) Driver: -25 to +70 °C [-13 to +158 °F] (non-freezing)
	Ambient Humidity	85% or less (non-condensing)
	Altitude	Up to 3000 m (10000 ft.) above sea level
	Surrounding atmosphere	No corrosive gas, dust, water or oil. Cannot be used in radioactive materials, magnetic field, vacuum or other special environment.
Shipping environment	Ambient temperature	Motor: -20 to +70 °C [-4 to +158 °F] (non-freezing) Driver: -25 to +70 °C [-13 to +158 °F] (non-freezing)
	Ambient Humidity	85% or less (non-condensing)
	Altitude	Up to 3000 m (10000 ft.) above sea level
	Surrounding atmosphere	No corrosive gas, dust, water or oil. Cannot be used in radioactive materials, magnetic field, vacuum or other special environment.
Degree of protection	Motor Standard type: IP40 IP65 type: IP65 (Excluding the connector section)	
	Driver: IP20	

- Unauthorized reproduction or copying of all or part of this manual is prohibited.
If a new copy is required to replace an original manual that has been damaged or lost, please contact your nearest Oriental Motor branch or sales office.
- Oriental Motor shall not be liable whatsoever for any problems relating to industrial property rights arising from use of any information, circuit, equipment or device provided or referenced in this manual.
- Characteristics, specifications and dimensions are subject to change without notice.
- While we make every effort to offer accurate information in the manual, we welcome your input. Should you find unclear descriptions, errors or omissions, please contact the nearest office.
- **Orientalmotor** is a registered trademark or trademark of Oriental Motor Co., Ltd., in Japan and other countries.
Other product names and company names mentioned in this manual may be registered trademarks or trademarks of their respective companies and are hereby acknowledged. The third-party products mentioned in this manual are recommended products, and references to their names shall not be construed as any form of performance guarantee. Oriental Motor is not liable whatsoever for the performance of these third-party products.

© Copyright ORIENTAL MOTOR CO., LTD. 2015

- Please contact your nearest Oriental Motor office for further information.

ORIENTAL MOTOR U.S.A. CORP.
Technical Support Tel:(800)468-3982
8:30 A.M. to 5:00 P.M., P.S.T. (M-F)
7:30 A.M. to 5:00 P.M., C.S.T. (M-F)
www.orientalmotor.com

ORIENTAL MOTOR DO BRASIL LTDA.
Tel:+55-11-3266-6018
www.orientalmotor.com.br

ORIENTAL MOTOR (EUROPA) GmbH
Schiessstraße 74, 40549 Düsseldorf, Germany
Technical Support Tel:00 800/22 55 66 22
www.orientalmotor.de

ORIENTAL MOTOR (UK) LTD.
Tel:01256-347090
www.oriental-motor.co.uk

ORIENTAL MOTOR (FRANCE) SARL
Tel:01 47 86 97 50
www.orientalmotor.fr

ORIENTAL MOTOR ITALIA s.r.l.
Tel:02-93906346
www.orientalmotor.it

ORIENTAL MOTOR ASIA PACIFIC PTE. LTD.
Singapore
Tel:1800-8420280
www.orientalmotor.com.sg

ORIENTAL MOTOR (MALAYSIA) SDN. BHD.
Tel:1800-806161
www.orientalmotor.com.my

ORIENTAL MOTOR (THAILAND) CO., LTD.
Tel:1800-888-881
www.orientalmotor.co.th

ORIENTAL MOTOR (INDIA) PVT. LTD.
Tel:+91-80-41125586
www.orientalmotor.co.in

TAIWAN ORIENTAL MOTOR CO., LTD.
Tel:0800-060708
www.orientalmotor.com.tw

SHANGHAI ORIENTAL MOTOR CO., LTD.
Tel:400-820-6516
www.orientalmotor.com.cn

INA ORIENTAL MOTOR CO., LTD.
Korea
Tel:080-777-2042
www.inaom.co.kr

ORIENTAL MOTOR CO., LTD.
Hong Kong Branch
Tel:+852-2427-9800

ORIENTAL MOTOR CO., LTD.
4-8-1 Higashiueno, Taito-ku, Tokyo
110-8536 Japan
Tel:03-6744-0361
www.orientalmotor.co.jp