

Brushless Motors

BLS Series Motor AC Input

OPERATING MANUAL

Thank you for purchasing an Oriental Motor product.

This operating manual describes product handling procedures and safety precautions.

- Please read the manual thoroughly to ensure safe operation.
- Always keep the manual where it is readily available.

Table of contents

1	Introduction	2	7	Grounding.....	22
2	Safety precautions	3	8	Inspection and maintenance	23
3	Precautions for use	5	8.1	Inspection.....	23
4	Preparation	7	8.2	Warranty.....	23
4.1	Checking the product	7	8.3	Disposal	23
4.2	How to identify the product model	7	9	Connection cables	24
4.3	Information about nameplate.....	8	10	Accessories	25
4.4	Products that can be combined	8	11	Specifications.....	26
4.5	Names of parts.....	9	12	Regulations and standards	27
5	Installation	10		When using an inverter in combination.....	28
5.1	Installation location.....	10			
5.2	Installation method.....	11			
5.3	Installing a load.....	16			
5.4	Permissible radial load and permissible axial load.....	19			
6	Connection	20			
6.1	Connecting the cable	20			
6.2	Removing the cable	21			

1 Introduction

■ Before using the product

Only qualified personnel of electrical and mechanical engineering should work with the product.

Use the product correctly after thoroughly reading the section "Safety precautions." In addition, be sure to observe the contents described in warning, caution, and note in this manual.

The product described in this manual is designed and manufactured to be incorporated into general industrial equipment. Do not use it for any other purpose. Oriental Motor Co., Ltd. is not responsible for any compensation for damage caused through failure to observe this warning.

■ Related operating manuals

The operating manual is not included with the product. Download them from Oriental Motor Website Download Page or contact your nearest Oriental Motor sales office. For details on connections and operation, refer to the operating manual of the driver.

- **BLS** Series Motor AC Input OPERATING MANUAL (this document)
- **BLS** Series Driver AC Input OPERATING MANUAL

When using an inverter in combination





Brushless motors described in this document can be combined with an inverter in addition to use with the dedicated driver.

They can be operated by the functions equipped with the inverter and via the industrial network.

Refer to p.28 for details on the connection method.

2 Safety precautions

The precautions described below are intended to ensure the safe and proper use of the product and to prevent the user and other personnel from exposure to the risk of injury. Use the product only after carefully reading and fully understanding these instructions.

 WARNING	Handling the product without observing the instructions that accompany a “WARNING” symbol may result in serious injury or death.
 CAUTION	Handling the product without observing the instructions that accompany a “CAUTION” symbol may result in injury or property damage.
 Note	The items under this heading contain important handling instructions that the user should observe to ensure safe use of the product.
 memo	The items under this heading contain related information and contents to gain a further understanding of the text in this manual.

WARNING

General

- Assign qualified personnel to the task of installing, wiring, operating/controlling, inspecting, and troubleshooting the product. Handling by unqualified personnel may result in fire, electric shock, injury, or damage to equipment.
- Do not use the product in explosive or corrosive environments, in the presence of flammable gases, in areas subjected to splashing water, or near combustible materials. Doing so may result in fire, electric shock, or injury.
- Do not transport, install, connect, or inspect the product while the power is supplied. Always turn off the power before carrying out these operations. This may result in electric shock or damage to equipment.
- Do not use the motor beyond the specifications. Doing so may result in fire, electric shock, injury, or damage to equipment.
- Take measures to hold the moving part in position, as the motor will stop and lose its holding force if an alarm is generated in the driver (a protective function of the driver is triggered). Failure to do so may result in injury or damage to equipment.
- When using the product in a vertical drive application such as elevating equipment, be sure to take measures to hold the moving part in position. Failure to do so may result in injury or damage to equipment.
- Keep your fingers and objects out of the openings in the motor. This may result in fire, electric shock, or injury.

Installation

- Install the motor in an enclosure. Failure to do so may result in electric shock or injury.
- Keep the area around the motor free of combustible materials. This may result in fire or a skin burn(s).

Connection

- Do not machine or modify the cable. Doing so may result in fire, electrical shock, or damage to equipment.
- Do not forcibly bend, pull, or pinch the cable. Doing so may result in fire, electrical shock, or damage to equipment.
- Do not apply a strong force to the connector or the terminal. Doing so may damage to the connector or the terminal, resulting in fire, electric shock, or damage to equipment.
- Do not damage the O-ring of the connector for cable connection. If the O-ring is damaged, the IP66 rating may not be met, resulting in fire, electric shock, or damage to equipment.
- Be sure to ground the motor as it is Class I equipment. Failure to do so may result in electric shock.

Operation

- Use a motor and driver only in the specified combination. An incorrect combination may cause fire or damage to equipment.

Maintenance and inspection

- Do not touch the motor or driver when conducting the insulation resistance measurement or dielectric strength test. Accidental contact may result in electric shock.
- Always turn off the power before performing maintenance or inspection. Failure to do so may result in electric shock.

Repair, disassembly, and modification

- Do not disassemble or modify the motor. Doing so may result in injury or damage to equipment.



General

- Do not touch the motor during operation or immediately after stopping. The surface of the motor is hot and it may cause a skin burn(s).

Installation

- Since the motor is very heavy, make sure that two or more people work together to perform the necessary tasks when transporting or installing it. Failure to do so may result in injury.
- Do not lift the motor by holding the output shaft or the cable. Doing so may result in injury.
- Do not touch the motor output shaft (shaft end or pinion section) with bare hands. Doing so may result in injury.
- Do not leave anything around the motor that would obstruct ventilation. Doing so may result in damage to equipment.
- Securely install the motor on the mounting plate. Inappropriate installation may cause the motor to detach and fall, resulting in injury or damage to equipment.
- When assembling the motor and the gearhead, be careful not to get your fingers or any other part of your body caught between the motor and the gearhead. Injury may result.
- When installing the motor in equipment, be careful not to get your fingers or any other part of your body caught between the motor and the equipment. Injury may result.
- Install the safety cover on the output shaft. Failure to do so may result in injury.
- Securely install a load on the output shaft. Failure to do so may result in injury.

Operation

- Do not touch the rotating part (output shaft) during operation. Doing so may result in injury.
- Provide an emergency-stop device or emergency-stop circuit external to the equipment so that the entire equipment will operate safely in the event of a system failure or malfunction. Failure to do so may result in injury.
- The motor surface temperature may exceed 70 °C (158 °F) even under normal operating conditions. If the operator is allowed to approach the operating motor, attach a warning label on a conspicuous position as shown in the figure. Failure to do so may result in a skin burn(s).



Warning label

3 Precautions for use

This chapter describes restrictions and requirements that the user should consider when using the product.

■ Connecting a motor and a driver

Always use a connection cable of Oriental Motor to connect a motor and a driver. Refer to "9 Connection cables" on p.24 for the connection cable models.

■ Connecting a motor and a connector

Do not apply a strong force to the locking lever of the connector for motor connection.

Applying a strong force to the locking lever may cause damage.

■ Notes about wiring

Fix the cable as shown in the figure so that the connector part of the cable is not stressed.

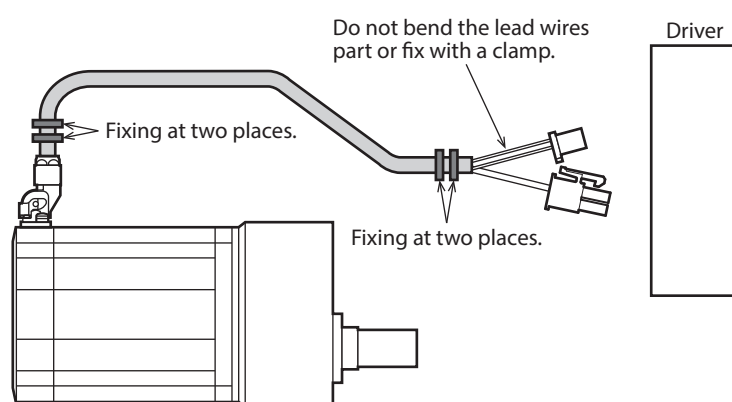

■ Insulation resistance measurement and dielectric strength test

When conducting the insulation resistance measurement or the dielectric strength test, be sure to separate the connection between the motor and the driver.

Conducting the insulation resistance measurement or the dielectric strength test with the motor and driver connected may result in damage to the product.

■ Grease measures

On rare occasions, grease may ooze out from the gearhead. If there is concern about potential environmental contamination from grease leakage, check for grease stains during periodic inspections. Alternatively, install an oil pan or other device to prevent damage from contamination. Oil leakage may lead to problems in the customer's equipment or products.

■ Apply grease to the hollow output shaft of a hollow shaft flat gearhead.

Apply grease (molybdenum disulfide grease, etc.) to the surface of the load shaft and the inner walls of the hollow output shaft to prevent seizure when a hollow shaft flat gearhead is used.

■ When using in low temperature environment

When the ambient temperature is low, the load torque may increase due to the oil seal or the viscosity of the grease used in the gearhead, and the output torque may decrease or the overload alarm may be generated. However, as time passes, the oil seal or grease is warmed up, and the motor can be operated without generating the overload alarm.

■ Motor with a key

When operating the motor with key in a state where a load is not installed, make sure to provide measures so that the key is not flown off. To fly off the key may result in injury or damage to equipment.

■ Rotation direction of the gearhead output shaft

The rotation direction of the gearhead output shaft may differ from that of the motor output shaft depending on the gear ratio of the gearhead.

The rotation direction of the motor output shaft is the direction as viewed from the motor output shaft side.

Refer to the operating manual of the driver for the rotation direction of the motor output shaft relative to the operation input signals of the driver.

● Parallel shaft gearhead

Gear ratio	Rotation direction of the gearhead output shaft
5, 10, 50	Same direction as the motor output shaft
15, 20, 30	Opposite direction to the motor output shaft

● Hollow shaft flat gearhead

The rotation directions of the gearhead output shaft relative to the motor output shaft are as shown in the figures below.

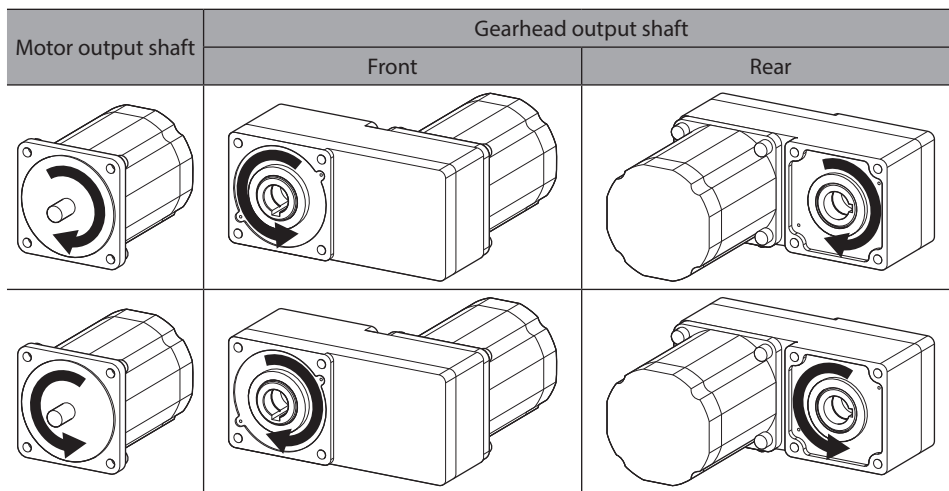

4 Preparation

This chapter describes the items to be prepared and the name and function of each part.

4.1 Checking the product

Verify that the items listed below are included.

Report any missing or damaged items to the branch or sales office from which you purchased the product.

■ Combination type-parallel shaft gearhead

- Motor 1 unit
- Parallel key 1 piece*
- Mounting screw 1 set
(Hexagon socket head cap screw, flat washer, spring washer: each 4 pieces)
- Instructions and Precautions for Safe Use 1 copy

* The parallel key is fixed to the gearhead output shaft.

■ Combination type-hollow shaft flat gearhead

- Motor 1 unit
- Parallel key 1 piece
- Mounting screw 1 set
(Hexagon socket head cap screw, flat washer, spring washer: each 4 pieces)
- Safety cover 1 set
(Safety cover: 1 piece, mounting screw for safety cover: 2 pieces)
- Instructions and Precautions for Safe Use 1 copy

■ Round shaft type

- Motor 1 unit
- Parallel key 1 piece*
- Instructions and Precautions for Safe Use 1 copy

* Included with round shaft types with a key.

The parallel key is fixed to the motor output shaft.

4.2 How to identify the product model

Verify the model name of the purchased product against the model shown on the name plate of the product.

Example of model name

- Combination type-hollow shaft flat gearhead

BL2M 6 750 C H P - 5 FR S
1 2 3 4 5 6 8 9 10

- Round shaft type

BL2M 6 750 C H P - A S
1 2 3 4 5 6 7 10

1	Motor type	BL2M: BLS Series motor
2	Frame size	6: 104 mm (4.09 in.)
3	Output power	750: 750 W
4	Power supply input	C: AC input
5	Motor connection method	H: Connector type
6	Degree of protection for motor	P: IP66
7	Output shaft type	A: Round shaft type K: Round shaft type with a key
8	Gear ratio	Number: Gear ratio of gearhead
9	Gearhead type	Blank: Parallel shaft gearhead FR: Hollow shaft flat gearhead
10	Material of output shaft	S: Stainless steel

4.3 Information about nameplate

Tell us the model name, product serial number, and manufacturing date when you contact us.

■ Motor

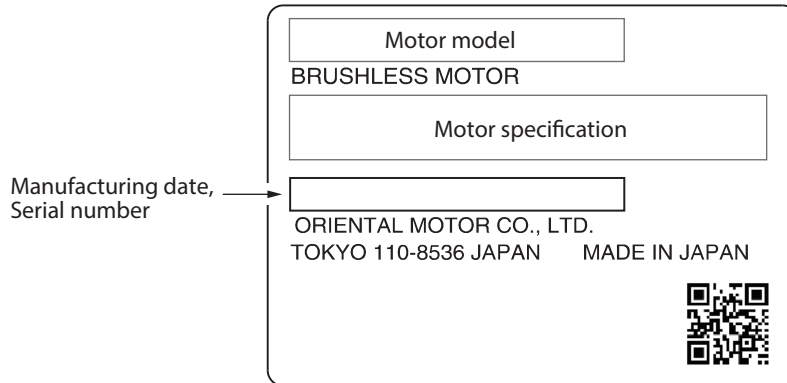

■ Gearhead



4.4 Products that can be combined

Verify the model name of the purchased product against the model shown on the package label. Check the motor model and the gearhead model against the model name shown on their nameplates, respectively. The box (□) in the model name indicates a number representing the gear ratio.

■ Combination type-parallel shaft gearhead

Combination type motor			Driver model
Model name	Motor model	Gearhead model	
BL2M6750CHP-□S	BL2M6750CHP-GR	6GR□S2	BLSD750-C

■ Combination type-hollow shaft flat gearhead

Combination type motor			Driver model
Model name	Motor model	Gearhead model	
BL2M6750CHP-□FRS	BL2M6750CHP-GR	6GR□FRS2	BLSD750-C

■ Round shaft type

Motor model	Driver model
BL2M6750CHP-AS BL2M6750CHP-KS	BLSD750-C

4.5 Names of parts

■ Combination type-parallel shaft gearhead (Example: BL2M6750CHP-10S)

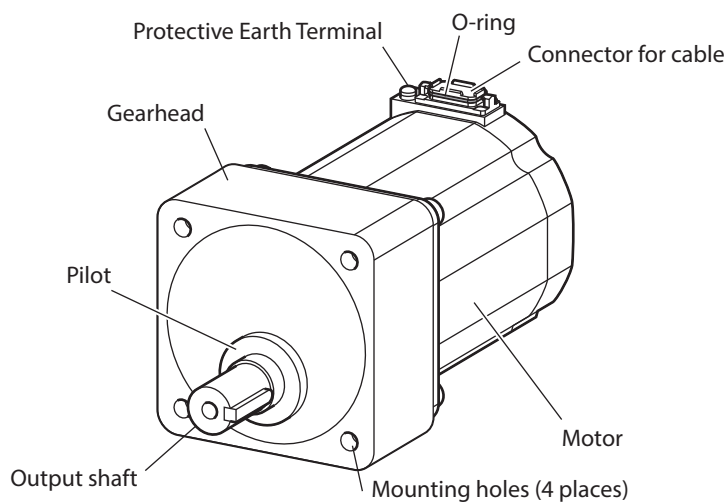

■ Combination type-hollow shaft flat gearhead (Example: BL2M6750CHP-10FRS)

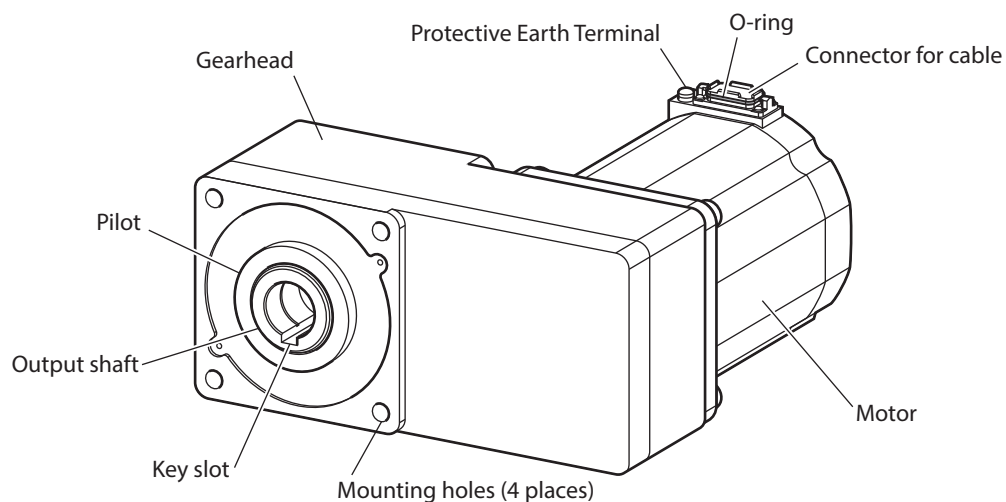

■ Connection cable (Sold separately)

To connect a motor and a driver, the dedicated connection cable is required. Purchase is required separately. Refer to "9 Connection cables" on p.24 for the connection cable models.

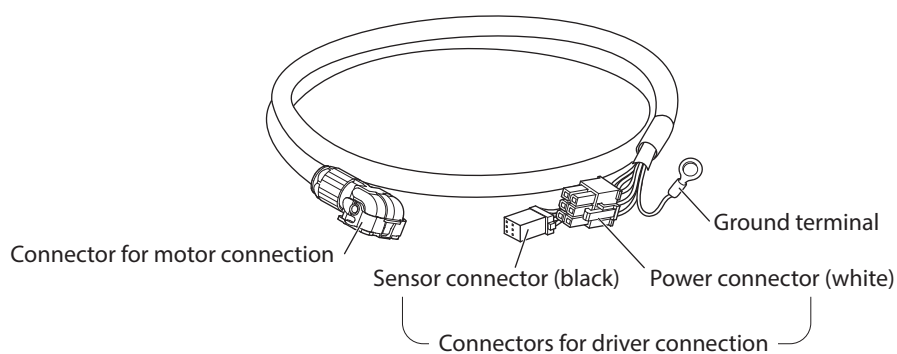

5 Installation

This chapter describes where and how to install the product and how to install a load.

5.1 Installation location

Install the product in a well-ventilated location that provides easy access for inspection. The location must also satisfy the following conditions:

Install it onto an appropriate flat plate having excellent vibration resistance and heat conductivity.

- Indoors
- Operating ambient temperature 0 to +40 °C [+32 to 104°F] (non-freezing)
- Operating ambient humidity 85 % or less (non-condensing)
- Area free of explosive atmosphere, toxic gas (such as sulfuric gas), or liquid
- Area not exposed to direct sun
- Area free of excessive amount of dust, iron particles, or the like
- Area free of excessive salt
- Area not subject to continuous vibration or excessive shocks
- Area free of excessive electromagnetic noise (from welders, power machinery, etc.)
- Area free of radioactive materials, magnetic fields, or vacuum
- Altitude Up to 1000 m (3300 ft.) above sea level
- Area not subject to oil (oil droplets) or chemicals

The motor can be used in an environment where it is splashed with water (the combination type and round shaft type motors when a connection cable is attached, and except for the connectors for driver connection and the mounting surface of the round shaft type motor).

However, do not use it under water or in high water pressure.

5.2 Installation method

■ Combination type-parallel shaft gearhead

Installing to equipment

The motor can be installed in any direction. Install it securely to a metal surface that is as rigid as possible, taking into account heat dissipation and vibration prevention.

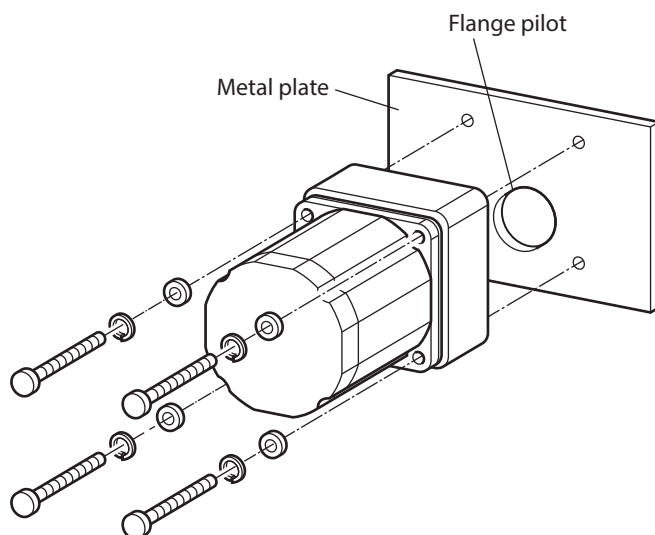

● Mounting Hole Dimensions [Unit: mm (in.)]

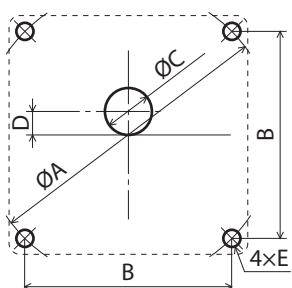

Gearhead model	ØA	B	ØC	D	E
6GR□S2	120 (4.72)	84.86 (3.34)	42 (1.65)	20 (0.79)	M8

ØC indicates the external dimensions of the product.
Drill holes with a minimum diameter of ØC + 1 mm (0.04 in.).

● Nominal designation of thread, tightening torque

The values of the tightening torque are recommended. Tighten the screws to an appropriate torque according to the design conditions of the metal plate.

Gear ratio	Nominal designation of thread	L1 [mm (in.)]	L2 [mm (in.)]	Tightening torque [N·m (lb-in)]
5, 10	M8	85 (3.35)	11 (0.43)	12 (106)
15, 20, 30, 50		110 (4.33)	10 (0.39)	

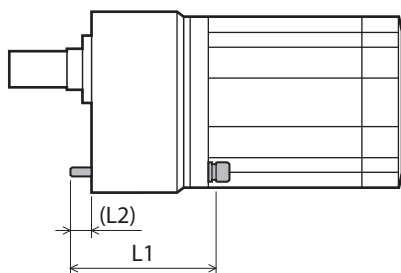

Removing/assembling a motor and a gearhead

This is the procedure for replacing the gearhead or changing the connector position.

1. Remove the gearhead from the motor

Remove the hexagonal socket head cap screws (2 places) securing the motor and gearhead, and remove the gearhead from the motor.

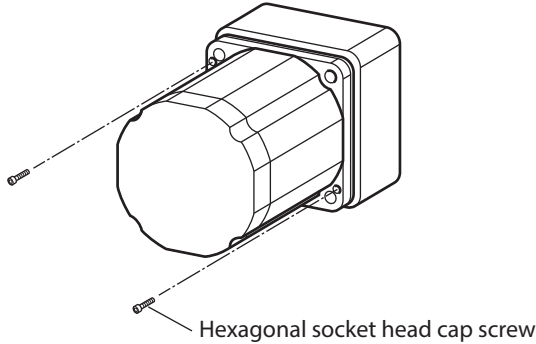

2. Assembling the gearhead to the motor

1) Keep the pilot sections of the motor and gearhead parallel, and assemble the gearhead to the motor while slowly rotating it clockwise/counterclockwise. At this time, make sure that the pinion of the motor output shaft does not hit the side panel or gears of the gearhead strongly.

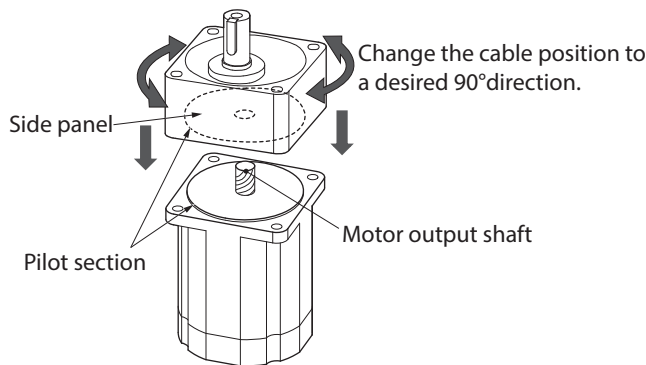

Assemble the gearhead to the motor in a condition where the motor output shaft is in an upward direction.

- 2) Check that there is no gap between the motor and gearhead, and tighten with hexagon socket head cap screws (2 places).

Gearhead model	Nominal designation of thread	Tightening torque [N·m (lb-in)]
6GR□S2	M3	0.6 (5.3)

Note

- Do not forcibly assemble the motor and gearhead. Also, do not allow metal objects or foreign substances to enter the gearhead. The pinion of the motor output shaft or gear may be damaged, resulting in noise or reduction in service life.
- Do not allow dust to attach to the pilot sections of the motor and gearhead. Also, assemble the motor and gearhead carefully to avoid pinching the O-ring on the motor pilot section. If the O-ring is crushed or severed, grease may leak from the gearhead.

■ Motor (Round shaft type)

Secure the four mounting holes of the motor using hexagon socket head cap screws (not included).
Install so that there is no gap between the motor and the mounting plate.

Nominal designation of thread	Tightening torque [N·m (lb-in)]
M8	12 (106)

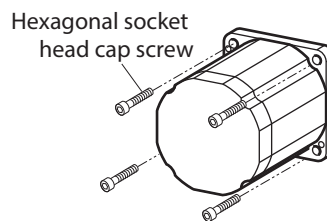

Install the motor on a mounting plate of the following size or larger, so that the motor case temperature does not exceed 90 °C (194 °F).

Size of mounting plate [mm (in.)]	Thickness [mm (in.)]	Material
350 × 350 (13.78 × 13.78)	10 (0.39)	Aluminum alloy

Note Do not install the motor to the mounting hole diagonally or assemble the motor forcibly. Doing so may cause damage to the flange pilot section, thereby resulting in damage to the motor.

■ Combination type-hollow shaft flat gearhead

Installing to equipment

The motor can be installed in any direction. Install it securely to a metal surface that is as rigid as possible, taking into account heat dissipation and vibration prevention.

Use the included hexagon socket head cap screw set to install the product.

● Nominal designation of thread, tightening torque

The values of the tightening torque are recommended. Tighten the screws to an appropriate torque according to the design conditions of the metal plate.

Nominal designation of thread	L1 [mm (in.)]	L2 [mm (in.)]	Tightening torque [N·m (lb-in)]
M8	100 (3.94)	13 (0.51)	12 (106)

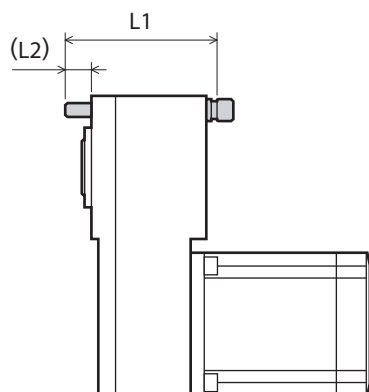

● Using the front face as the mounting surface

The center axes of the motor and the metal plate can be aligned using the pilot.

Mounting Hole Dimensions [Unit: mm (in.)]

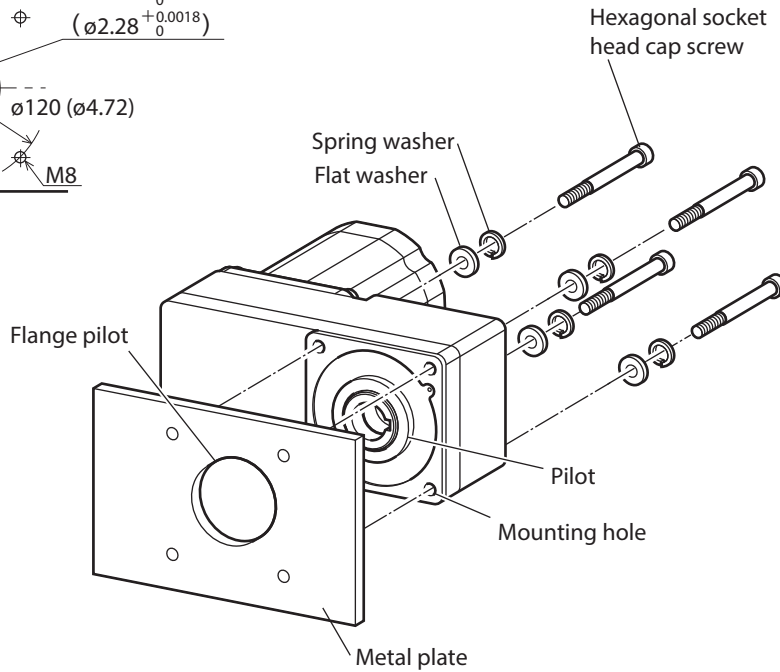
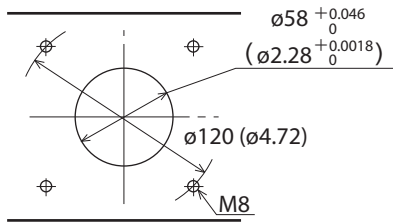

● Using the rear face as the mounting surface

When installing using the rear face, the center axes of the motor and the metal plate cannot be aligned due to no pilot. If the centering is needed, adjust the center axes by yourself.

Mounting Hole Dimensions [Unit: mm (in.)]

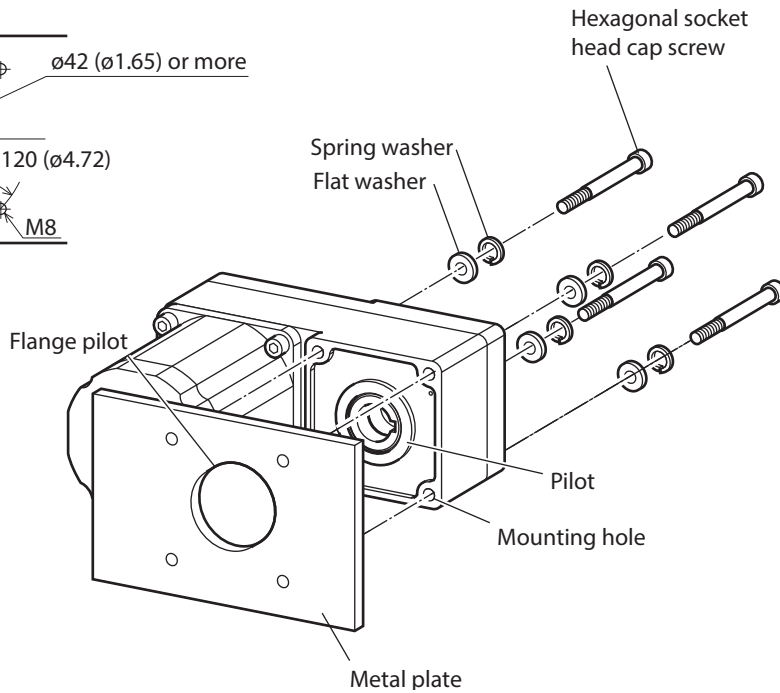
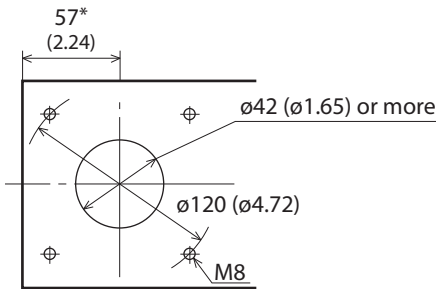

* It is the distance from the motor to the center of the output shaft when the motor is placed on the left side.

● **Attaching the safety cover**

After installing the load shaft, install the included safety cover to prevent the output shaft from being touched.

The safety cover can be attached on either side.

Tightening torque: 0.45 N·m (3.9 lb-in)

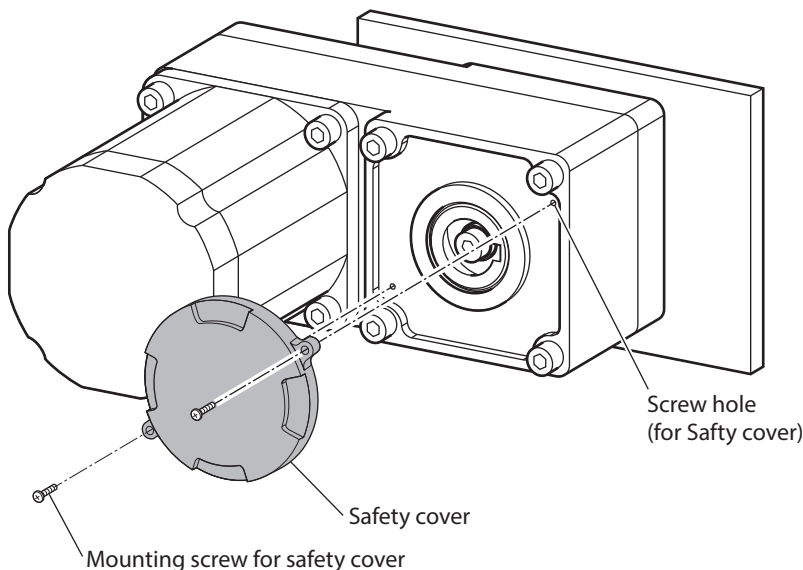

Removing/assembling a motor and a gearhead

This is the procedure for replacing the gearhead or changing the connector position.

1. Remove the gearhead from the motor
Remove the hexagon socket head cap screws (4 places) securing the motor and gearhead, and remove the gearhead from the motor.

2. Assembling the gearhead to the motor
 - 1) Keep the pilot sections of the motor and gearhead parallel, and assemble the gearhead to the motor while slowly rotating it clockwise/ counterclockwise.
At this time, make sure that the pinion of the motor output shaft does not hit the side panel or gears of the gearhead strongly.

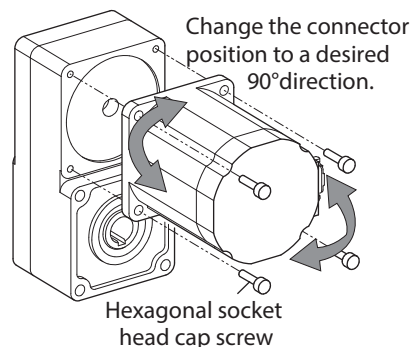

- 2) Check that there is no gap between the motor and the gearhead, and tighten them with hexagon socket head cap screws (4 places).

Gearhead model	Nominal designation of thread	Tightening torque [N·m (lb-in)]
6GR□FRS2	M8	12 (106)

The box (□) in the gearhead model name indicates a gear ratio.

- Note**
- Do not forcibly assemble the motor and gearhead. Also, do not allow metal objects or foreign substances to enter the gearhead. The pinion of the motor output shaft or gear may be damaged, resulting in noise or reduction in service life.
 - Do not allow dust to attach to the pilot sections of the motor and gearhead. Also, assemble the motor and gearhead carefully to avoid pinching the O-ring on the motor pilot section. If the O-ring is crushed or damaged, grease may leak from the gearhead.

5.3 Installing a load

When installing a load, align the centers of the output shaft and the load.

- Note**
- When installing a load, pay attention to centering, belt tension, parallelism of pulleys, etc. Also, firmly secure the tightening screws of the coupling or pulleys.
 - When installing a load, do not damage the output shaft or the bearings. Forcing the load in by hitting it with a hammer, etc., may cause the bearing to break. Do not apply any excessive force to the output shaft.
 - Do not modify or machine the output shaft. This may damage the bearing, resulting in damage to the motor and gearhead.

■ Combination type-parallel shaft gearhead

● Output shaft shape

A key slot is provided on the output shaft of the gearhead. Machine a key slot on the load side and secure the load using the included parallel key.

● How to install a load

Using a coupling

Align the centers of the output shaft and load shaft in a straight line.

Using a belt

Align the output shaft and load shaft in parallel and make sure the line connecting the centers of the two pulleys is perpendicular to the shafts.

Using a gear drive

Align the output shaft and gear shaft in parallel and allow the gears to mesh at the center of the tooth widths.

When using the output shaft end screw hole of a gearhead

Use a screw hole provided at the end of the output shaft as an auxiliary means to prevent the transmission parts from disengaging.

The box (□) in the gearhead model name indicates a gear ratio.

Gearhead model	Output shaft end screw hole
6GR□S2	M6, Effective depth 12 mm (0.47 in)

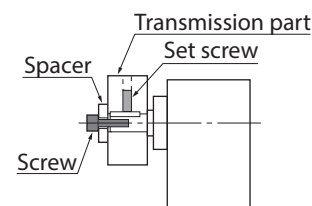

Example of use for the output shaft end screw hole

■ Combination type-hollow shaft flat gearhead

If a large impact occurs at instantaneous stop or a large radial load is applied, use a stepped load shaft.

- Note**
- Apply grease (molybdenum disulfide grease, etc.) to the surface of the load shaft and the inner walls of the hollow output shaft to prevent seizure.

● When the stepped load shaft is installed

Installation using an end plate

Use an end plate, flat washer, and spring washer to secure the load shaft with a screw.

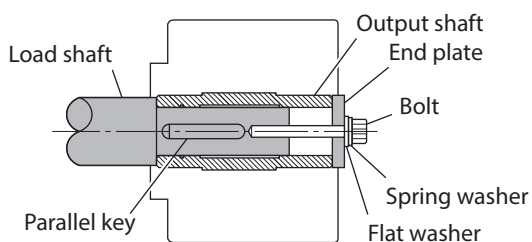
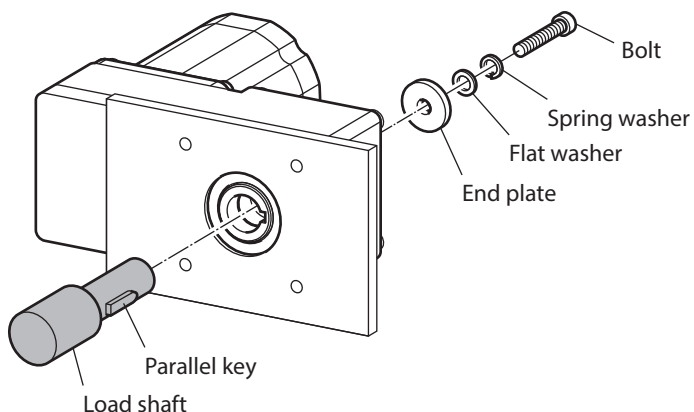

When installing the load shaft using an end plate, the included safety cover cannot be installed because it is in contact with the screw. You will need to take other measures to protect the output shaft.

Installation using a retaining ring for hole

First, place a retaining ring for hole. Then, use a spacer, flat washer, and spring washer to secure the load shaft with a screw.

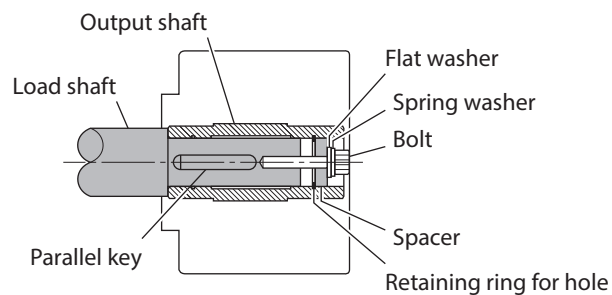
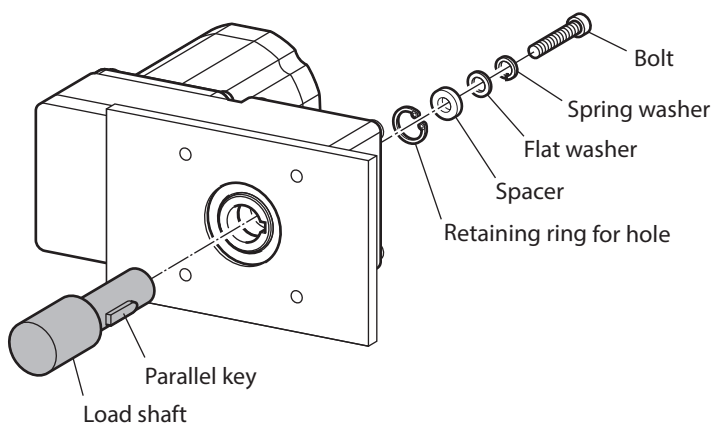

● **When the non-stepped load shaft is installed**

First, place a retaining ring for hole. Then, use spacers, a flat washer, and a spring washer to secure the load shaft with a screw.

Also place a spacer on the load shaft side.

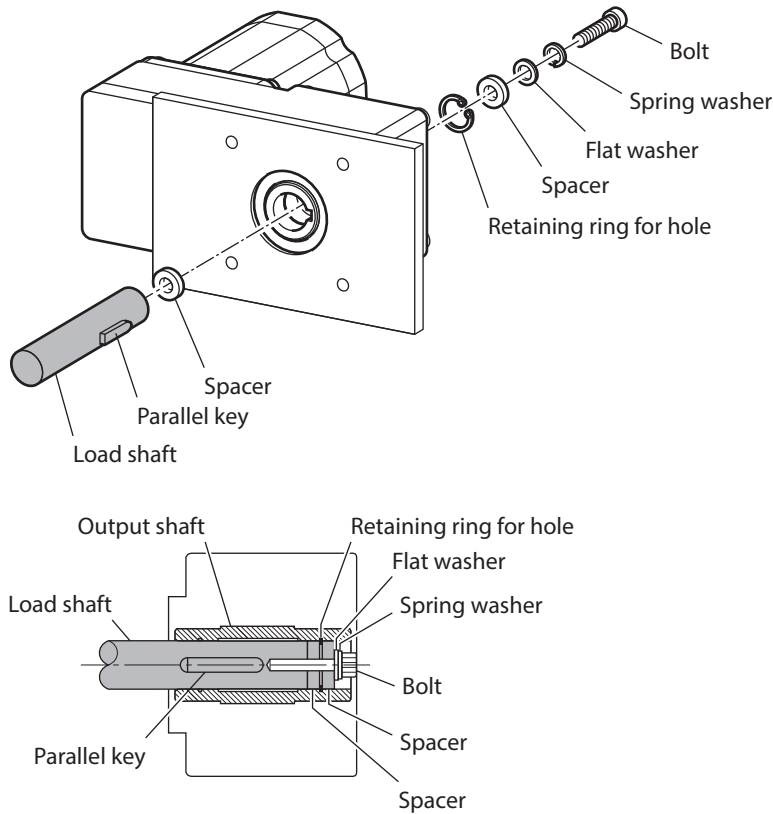

Recommended load shaft installation dimensions [Unit: mm (in.)]

Gearhead model	Inner diameter of hollow shaft (H8)	Recommended diameter of load shaft (h7)	Nominal diameter of retaining ring for hole	Applicable screw	Spacer thickness	Outer diameter of stepped shaft (ØD)
6GR□FRS2	$\text{Ø}25^{+0.033}_0$ ($\text{Ø}0.9843^{+0.0013}_0$)	$\text{Ø}25^0_{-0.021}$ ($\text{Ø}0.9843^0_{-0.0008}$)	$\text{Ø}25$ ($\text{Ø}0.98$)	M8	6 (0.24) [3 (0.12)]*	40 (1.57)

* The value in the brackets [] is that when using the rear face as the mounting surface.

■ **Motor (Round shaft type)**

Use a hexagon socket set screw (double-point), etc., to firmly secure the load so that it does not rotate idly.

For the round shaft type motors with a key, machine a key slot on the load side and secure the load using the included parallel key.

5.4 Permissible radial load and permissible axial load

Make sure that the radial load and axial load applied to the output shaft do not exceed the permissible values shown in the table below.

Note Failure due to fatigue may occur when the motor or gearhead bearings and output shaft are repeatedly subjected to the radial or axial load that exceeds the permissible limit.

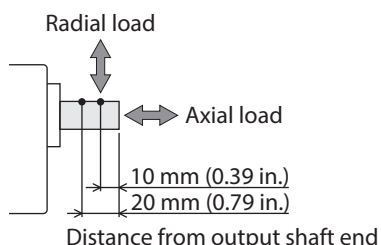

■ Combination type-parallel shaft gearhead

The values are based on a rated speed of 3000 r/min or less. The values in parentheses [] are based on a rated speed of 4000 r/min.

Gearhead model	□: Gear ratio	Permissible radial load [N (lb.)] Distance from the output shaft end of the gearhead		Permissible axial load [N (lb.)]
		10 mm (0.39 in.)	20 mm (0.79 in.)	
6GR□S2	5, 10	550 (123) [500 (112)]	800 (180) [700 (157)]	200 (45)
	15, 20, 30	1000 (220) [900 (200)]	1250 (280) [1100 (240)]	300 (67)
	50	1300 (290) [1200 (270)]	1450 (320) [1300 (290)]	400 (90)

■ Combination type-hollow shaft flat gearhead

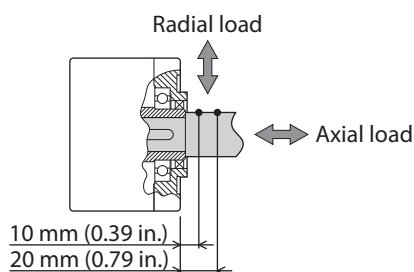

Distance from mounting surface

The values are based on a rated speed of 3000 r/min or less. The values in parentheses () are based on a rated speed of 4000 r/min.

Gearhead model	□: Gear ratio	Permissible radial load [N (lb.)] Distance from the gearhead mounting surface		Permissible axial load [N (lb.)]
		10 mm (0.39 in.)	20 mm (0.79 in.)	
6GR□FRS2	5, 10	1230 (270) [1130 (250)]	1070 (240) [990 (220)]	800 (180)
	15, 20	1680 (370) [1550 (340)]	1470 (330) [1360 (300)]	
	30, 50	2040 (450) [1900 (420)]	1780 (400) [1660 (370)]	

■ Motor (Round shaft type)

Permissible radial load [N (lb.)] Distance from the output shaft end of the motor		Permissible axial load [N (lb.)]
10 mm (0.39 in.)	20 mm (0.79 in.)	
262 (58)	304 (68)	25 (5.6)

6 Connection

6.1 Connecting the cable

1. Remove the connector cap.

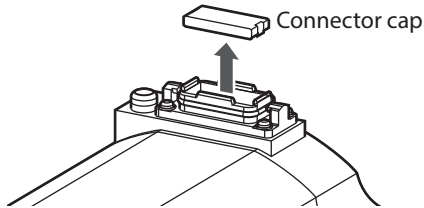

Note Do not damage the O-ring of the connector when removing the connector cap.

2. Connect the connector of the connection cable.
The figure shows an example where the cable outlet direction is opposite to the output shaft direction. Check the position of the connector terminals before connecting.

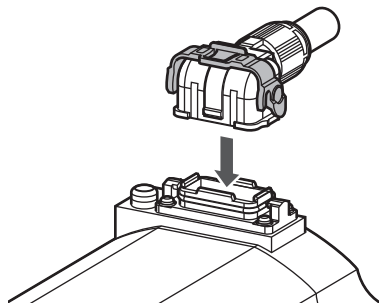

- Position of locking lever when connecting the connector
Avoid 90-degree and 0-degree positions.

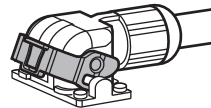

Note If the locking lever is in a state of being turned up to the 90-degree position or down to the 0-degree position, parts around the locking lever and the connector are in contact with each other, and the connectors cannot be connected.

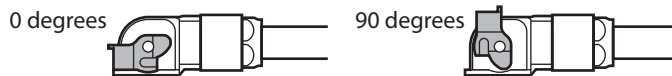

3. Turn the locking lever down to the 0-degree position to fix the connector.

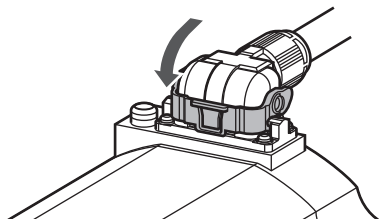

■ Handling of locking lever

- Do not apply excessive force to the locking lever. If the locking lever is damaged, the connector may not be fixed securely.
- After connecting the connector, turn the locking lever down securely to the 0-degree position to fix the connector.



WARNING

Be sure to turn down the locking lever. If the connector is not fixed, the cable may come off or the IP66 rating may not be met, resulting in fire, electric shock, or damage to equipment.

6.2 Removing the cable

Turn up the locking lever and pull out the connector.



Turning up the locking lever to the 90-degree position simultaneously disconnects the connector.

7 Grounding

■ Grounding

Use the Protective Earth Terminal \oplus of the motor and the ground terminal of the connection cable to ground.



Be sure to ground the motor. Failure to do so may result in electric shock or damage to the product.

If not grounded, static electricity may damage the product.

The grounding resistance specified in the standards applied to the equipment may not be satisfied depending on the type or length of the connection cable.

In this case, ground near the motor using the Protective Earth Terminal \oplus of the motor.

When the ground terminal of the connection cable is not used, be sure to insulate it.

Grounding wire with terminal

- Applicable crimp terminal: Ring crimp terminal with insulation cover
- Applicable lead wire: AWG 18 to AWG 14 (0.75 to 2.0 mm²)
- Screw size: M4
- Tightening torque: 1.2 N·m (10.6 lb-in)

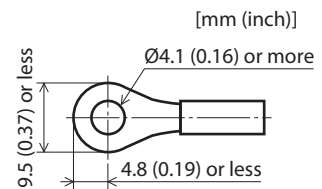

8 Inspection and maintenance

8.1 Inspection

It is recommended that the following items be inspected periodically after each operation of the motor. If any abnormality occurs, discontinue use of the product and contact your nearest Oriental Motor sales office.

Note Do not conduct the insulation resistance measurement or dielectric strength test with the motor and driver connected.
Doing so may damage the product.

■ Inspection items

- Check to see if any of the mounting screws of the motor and gearhead are loose.
- Check to see if the bearing part (ball bearings) of the motor makes an unusual noise.
- Check to see if the bearing part (ball bearings) or the gear meshing part of the gearhead makes an unusual noise.
- Check to see if the output shaft of the motor and gearhead and a load shaft are out of alignment.
- Check to see if the cable is damaged or stressed, or if the connection between the motor/cable and driver is loose.
- Check to see if the locking lever of the connection cable is damaged.
- Check to see if the locking lever of the connection cable is come off.

8.2 Warranty

Check on the Oriental Motor Website for the product warranty.

8.3 Disposal

Dispose the product correctly in accordance with laws and regulations, or instructions of local governments.

9 Connection cables

■ Connection cables

The model name of the connection cable varies depending on the direction of the cable outlet from the motor. Refer to the figures below.

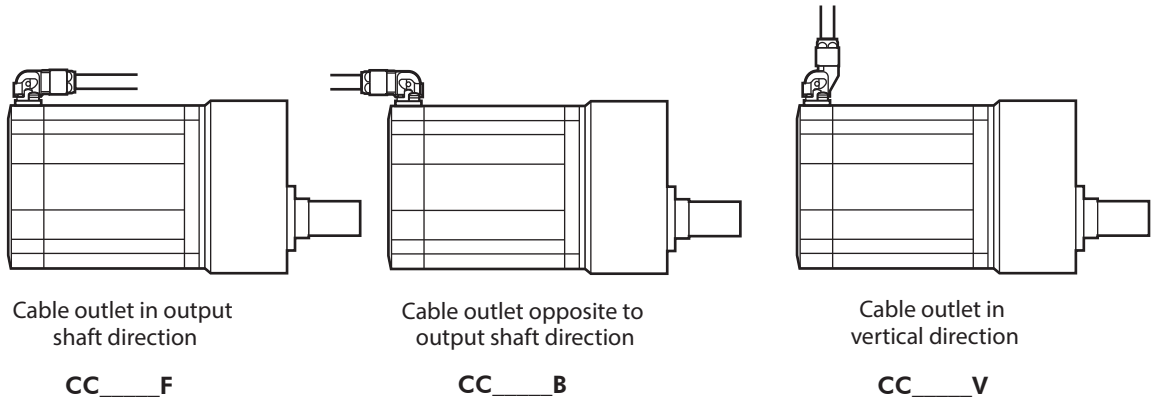

The box (■) in the model name indicates **F**, **B**, or **V**, which represents the cable outlet direction.

● Connection cable

Length	Model name
0.5 m (1.6 ft.)	CC005KHBL■
1 m (3.3 ft.)	CC010KHBL■
1.5 m (4.9 ft.)	CC015KHBL■
2 m (6.6 ft.)	CC020KHBL■
2.5 m (8.2 ft.)	CC025KHBL■
3 m (9.8 ft.)	CC030KHBL■
4 m (13.1 ft.)	CC040KHBL■
5 m (16.4 ft.)	CC050KHBL■
7 m (23.0 ft.)	CC070KHBL■
10 m (32.8 ft.)	CC100KHBL■
15 m (49.2 ft.)	CC150KHBL■
20 m (65.6 ft.)	CC200KHBL■

10 Accessories

Couplings and mounting brackets can be checked on the Oriental Motor Website.

■ About the mounting brackets (SOL) of the motor

When a mounting bracket and a motor are assembled, install the motor on the bracket in a state where the position of the connector for motor connection is on the top or side of the motor. It is not recommended to install the motor in a state where the position of the motor cable is under the motor as it will come in contact with the mounting bracket or the installation surface.

11 Specifications

■ General specifications

Operating environment	Ambient temperature	0 to +40 °C (+32 to +104 °F) (non-freezing)
	Ambient humidity	85 % or less (non-condensing)
	Altitude	Up to 1000 m (3300 ft.) above sea level
	Surrounding atmosphere	No corrosive gas or dust. No water or oil. Cannot be used in radioactive materials, magnetic field, vacuum or other special environments.
	Vibration	Not subject to continuous vibration or excessive impact. In conformance with JIS C 60068-2-6 "Sine-wave vibration test method" Frequency range: 10 to 55 Hz Pulsating amplitude: 0.15 mm (0.006 in.) Sweep direction: 3 directions (X, Y, Z) Number of sweeps: 20 times
Storage environment	Ambient temperature	-20 to +70 °C (-4 to +158 °F) (non-freezing)
	Ambient humidity	85 % or less (non-condensing)
Shipping environment	Altitude	Up to 3000 m (10000 ft.) above sea level
	Surrounding atmosphere	No corrosive gas or dust. No water or oil. Cannot be used in radioactive materials, magnetic field, vacuum or other special environments.
Degree of protection	IP66	Combination type motor (motor with parallel shaft gearhead GR or hollow shaft flat gearhead), round shaft type motor (When a connection cable is attached. Except for the connectors for driver connection and the mounting surface of the round shaft type motor)

12 Regulations and standards

■ UL Standards, CSA Standards

This product is recognized by UL under UL and CSA Standards.

■ CE Marking /UKCA Marking

This product is affixed with the mark under the following directives /regulations.

● EU Low Voltage Directive /UK Electrical Equipment (Safety) Regulations

Installation conditions

- Overvoltage category: II
- Pollution degree: 3
- Protection against electric shock: Class I equipment

● EU EMC Directive / UK EMC Regulations

The EMC test is conducted in a state where the motor is connected to the driver.

The driver that is combined with the motor complies with the EMC Directive/ Regulations.

Refer to the OPERATING MANUAL for the driver.

● EU RoHS Directive /UK RoHS Regulation

This product does not contain the substances exceeding the restriction values.

■ China Energy Efficiency Regulations

- Applicable Products: Motors with an output of 550 W or more
- Applicable Standard: GB 30253

Read the QR code on the China Energy Label affixed to the motor to check.



When using an inverter in combination

Note Be sure to set the electronic thermal relay according to the operating manual of the inverter. If the electronic thermal relay is not set, burnout may occur.

■ Connection with an inverter

Be sure to use the dedicated connection cable (connection terminals) to connect the inverter.
 Check on the Oriental Motor Website for the dedicated connection cable.
 Refer to "7 Grounding" on p.22 for grounding.

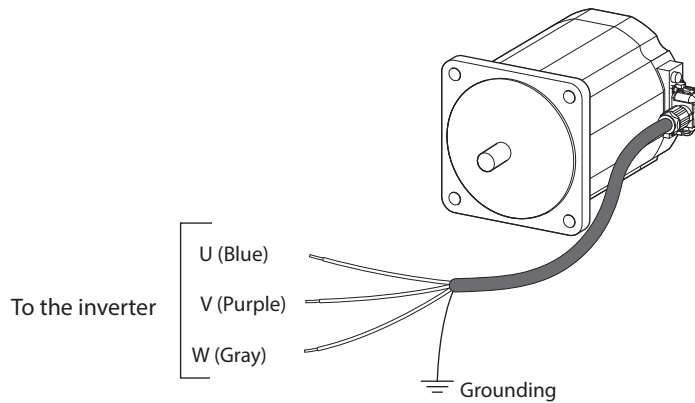

■ How to use

When the motor is used with connecting an inverter, perform the following settings to the inverter.
 When driving the motor, use it at the setting frequency 334 Hz or lower.

● Setting for motor

Electronic thermal relay function	Rated current: 3.6 A
Motor capacity	Motor rated output power If it does not exist in the setting value of the inverter, set the closest value.
Number of motor poles	10 poles

The above settings can be checked in the "Motor and Inverter Combination Data" on the website.

- Unauthorized reproduction or copying of all or part of this manual is prohibited.
If a new copy is required to replace an original manual that has been damaged or lost, please contact your nearest Oriental Motor sales office.
- Oriental Motor shall not be liable whatsoever for any problems relating to industrial property rights arising from use of any information, circuit, equipment or device provided or referenced in this manual.
- Characteristics, specifications and dimensions are subject to change without notice.
- While we make every effort to offer accurate information in the manual, we welcome your input. Should you find unclear descriptions, errors or omissions, please contact the nearest office.
- **Oriental motor** is a registered trademark or trademark of Oriental Motor Co., Ltd., in Japan and other countries.
Other product names and company names mentioned in this manual may be registered trademarks or trademarks of their respective companies and are hereby acknowledged. The third-party products mentioned in this manual are recommended products, and references to their names shall not be construed as any form of performance guarantee. Oriental Motor is not liable whatsoever for the performance of these third-party products.

© Copyright ORIENTAL MOTOR CO., LTD. 2024

Published in January 2026

- Please contact your nearest Oriental Motor office for further information.

ORIENTAL MOTOR U.S.A. CORP.
Technical Support Tel:800-468-3982
8:30am EST to 5:00pm PST (M-F)

ORIENTAL MOTOR (EUROPA) GmbH
Schiessstraße 44, 40549 Düsseldorf, Germany
Technical Support Tel:00 800/22 55 66 22

ORIENTAL MOTOR (UK) LTD.
Blythe Valley Business Park,
Central Blvd Blythe Valley Park,
Solihull B90 8AG, United Kingdom
Tel:+44-1926-671220

ORIENTAL MOTOR (FRANCE) SARL
Tel:+33-1 47 86 97 50

ORIENTAL MOTOR ITALIA s.r.l.
Tel:+39-02-93906347

ORIENTAL MOTOR ASIA PACIFIC PTE. LTD.
Singapore
Tel:1800-842-0280

ORIENTAL MOTOR (MALAYSIA) SDN. BHD.
Tel:1800-806-161

ORIENTAL MOTOR (THAILAND) CO., LTD.
Tel:1800-888-881

ORIENTAL MOTOR (INDIA) PVT. LTD.
Tel:1800-120-1995 (For English)
1800-121-4149 (For Hindi)

TAIWAN ORIENTAL MOTOR CO., LTD.
Tel:0800-060708

SHANGHAI ORIENTAL MOTOR CO., LTD.
Tel:400-820-6516

INA ORIENTAL MOTOR CO., LTD.
Korea
Tel:080-777-2042

ORIENTAL MOTOR CO., LTD.
4-8-1 Higashiueno, Taito-ku, Tokyo
110-8536 Japan
Tel:+81-3-6744-0361
www.orientalmotor.co.jp/ja